

## Arm Blood Pressure Monitor Instruction Manual

Software version: V1.1

Manual version: V1.1

Date: 2020-06



## Table of Contents

|   |    |
|---|----|
| 1、 Unpacking Inspection.....                      | 1  |
| 2、 Packing List.....                              | 1  |
| 3、 Safety Precautions.....                        | 2  |
| 4、 Product Composition.....                       | 3  |
| 5、 Intended for Use.....                          | 3  |
| 6、 Classification of BP (Blood Pressure).....     | 3  |
| 7、 Product Parts.....                             | 4  |
| 8、 Preparation.....                               | 5  |
| 9、 Function Setting.....                          | 6  |
| 10、 How to take proper measurements.....          | 9  |
| 11、 Contraindications, Precautions, Warnings..... | 15 |
| 12、 Common Q & A on Blood Pressure.....           | 18 |
| 13、 Abnormal Phenomena and Handling.....          | 21 |
| 14、 Maintenance.....                              | 23 |
| 15、 Product Specification.....                    | 25 |

Thank you for purchasing this Arm Blood Pressure Monitor. The monitor can be used and store measurement results for two users. It uses the oscillometric method of blood pressure measurement. This means this monitor detects your blood movement through your brachial artery and converts the movements into a digital reading.

## **1、 Unpacking Inspection**









Before use, please open the package carefully and check whether all the parts are available according to the following packing list and whether the parts are damaged during transportation, and then install and operate in strict accordance with the manual.

## **2、 Packing List**

| No. | Name                       | Quantity |
|-----|----------------------------|----------|
| 1   | Arm blood pressure monitor | 1        |
| 2   | Cuff 22-32 cm              | 1        |
| 3   | Instruction Muanul         | 1        |
| 4   | Dry Battery"AAA"           | 4        |
| 5   | Pouch                      | 1        |
| 6   | Quick start guide          | 1        |

### 3、 Safety Precautions

The warnings and illustrations shown in the manual are intended to enable you to use the product safely and correctly, thus preventing harm to you and others, specific meanings of which are shown as follows:

| Legend, mark and meaning  |  |
|---|--|
|    | Warning information,<br>refer to the attached document |
|    | BF-type anti –shock degree for the application<br>part |
|    | Comply with local regulations                          |
|    | Consult the instructions for use.                      |
|   | Keep dry   |
|  | Low voltage prompt                                     |
|  | keep out of the sun                                    |
|  | vertical upward  |

#### 4、 Product Composition

This product is composed of the main body and cuff of an arm blood pressure monitor.

#### 5、 Intended for Use

The arm blood pressure monitor is intended to measure the systolic pressure and diastolic pressure, as well as the pulse rate of adult person via non-invasive oscillometric technique at medical facilities or at home.

#### 6、 Classification of BP (Blood Pressure)

ACC/AHA 2017 Hypertension guidelines define categories of BP in adults as below.

Categories of BP in Adults\*

| BP Category                     | Systolic BP                  | Diastolic BP              |
|---------------------------------|------------------------------|---------------------------|
| Normal                          | < 120 mmHg                   | < 80 mmHg                 |
| Elevated                        | 120 - 129 mmHg               | < 80 mmHg                 |
| Hypertension<br>Stage 1 Stage 2 | 130-139mmHg or<br>≥ 140 mmHg | 80-89mmHg or<br>≥ 90 mmHg |

\* Individuals with Systolic BP and Diastolic BP in 2 categories should be designated to the higher BP category.

BP indicates blood pressure (based on an average of ≥ 2 careful readings obtained on ≥ 2 occasions).

Source: ACC/AHA 2017 High Blood Pressure Clinical Practice Guideline

## 7、Product Parts

### (1) Main body

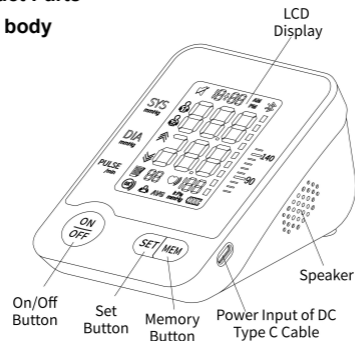

### (2) Display screen

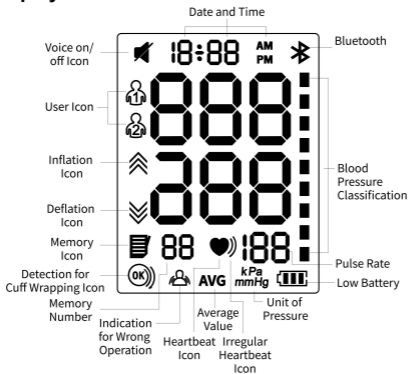

## 8、Preparation

### (1) Install the battery

1) Open the battery cover according to the method shown in the figure (as shown in the above figure)

2) Place 4 AAA dry batteries in the battery compartment, and pay attention to the electrode indication of the batteries. Install the battery as indicated in the picture right under this sentence.

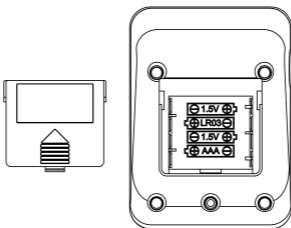

### (2) Battery replacement



If the product is not used for a long time (over 3 months), please take out the batteries.

### (3) Type C connection for power supply (The cable is optional)

The product power can be supplied by plugging into DC 5V



external power supply through a Type C interface.

## 9、Function Setting

### (1) User mode

In standby mode, press the "SET" button to enter the user group selection interface. Then press the "SET" button to switch and select user groups.

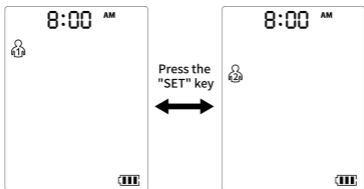

### (2) Year/month/Date/setting

In standby mode, press "SET" for about 3 seconds to enter the date setting, and "year" will flash. Press "MEM" to adjust to the desired year, and then press "SET" to confirm the selection. When the "year" is set, it will automatically enter the month setting. At this time, the "month" icon will flash. You can switch to the desired value by pressing the "MEM" button. Follow the same step to set "date", "hour", and "minute", and "voice on/off".

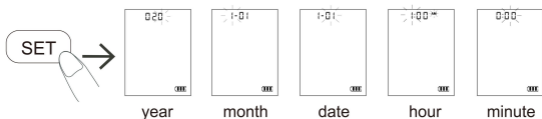

### (3) Talking function setting (voice version only, optional function)

1) After the time setting is finished, it will automatically enter the voice setting (the screen will display "SP"). Short press "memory" button to switch ON/OFF sound, "ON" means open voice, "OFF" means close voice, short press "set" button to confirm and select;

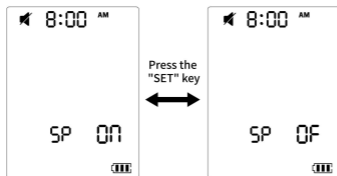

2) Voice broadcast content:

Attention, please!

Please keep silent and relax.

Keep the cuff at the heart level.

① If your blood pressure is in normal range:

Thank you.

Your blood pressure is:

Systolic pressure xxx millimeter of mercury pillar.

Diastolic pressure xx millimeter of mercury pillar.

Your pulse is xx beats per minute.

Measuring result is normal.

Thank you.

Wish you a good health.

② If your blood pressure is not in normal range:

Measuring result is abnormal.

Your blood pressure is high/low

Could not measure your pulse at this time.

③ Measuring error :

Error,(Mistake ),Please measure again

④ Other operation :

Average Blood Pressure

Last time your blood pressure was xxx, your pulse was xx

Low battery, please replace the battery

Low battery, please charge in time

#### (4) Unit display setting

In standby mode, keep pressing "ON/OFF" button for about 10 seconds to enter the unit selection, and press "MEM" to switch mmHg/kPa. Short press "SET" to confirm the selection;The default is mmHg before delivery.

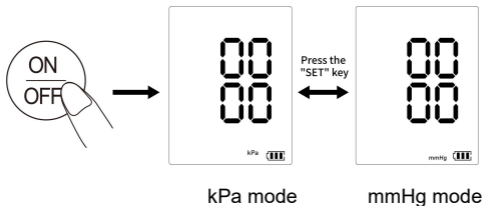

### 10、 How to take proper measurements

#### (1) Preparation before measurement

- Remove the clothing on the arm.
- Always measure in the same arm (generally the left arm).
- Remain still and keep quiet during measurement.
- Relax as much as possible and do not talk during measurement.
- Measure your blood pressure at about the same time every day.
- Do not measure right after physical exercise or a bath. Rest for 20 to 30 minutes before taking the measurement.

--Readings take under the conditions listed below may affect results:

Within an hour after dinner, after having wine, coffee, tea, sports; talking, being nervous, being in unsteady mood, bending forward, moving, room temperature dramatically changing during measuring; inside a moving vehicle, repeated and continuous measuring.

## **( 2 ) Attaching the arm cuff**

1) Plug the arm cuff into your monitor by inserting the air plug into the air jack securely until it clicks.

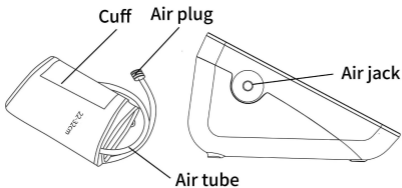

2) Place your hand through the cuff loop. Pull the cuff until it reaches your upper left arm.

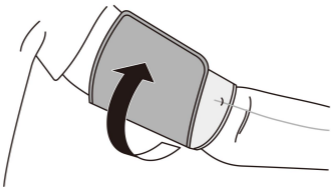

#### **Note**

- The bottom edge of the arm cuff should be 0.79-1.18 inches (2 to 3 cm) above the inside elbow. The air tube is on the inside of your arm and aligned with your middle finger.

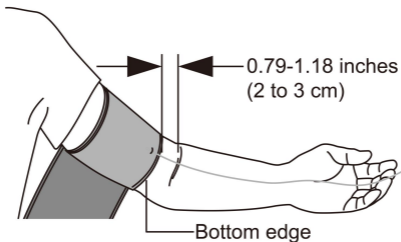

3) Make sure that the air tube is positioned on the inside of your arm and wrap the cuff securely, so it can not move around your arm.

4) To take a measurement on your right arm

When you take a measurement on your right arm, the air tube should run along the side of your elbow, along the bottom of your arm. Be careful not to rest your arm on the air tube.

**Note:** Repeated measurement will result in blood congestion in the arm, which will affect the measurement result. How to improve: raise the left hand and hold the fist several times, or take off the cuff and rest for at least 2-3 minutes before taking the measurement.

### **(3) Sitting Correctly**

To take a measurement, you need to be relaxed and comfortably seated in a room with a comfortable temperature. Place your arm on the table.

- Sit in a comfortable chair with your back and arm supported.
- Keep your feet flat and your legs uncrossed.
- The arm cuff should be placed on your arm at the same level as your heart, with the arm resting comfortably on a table.

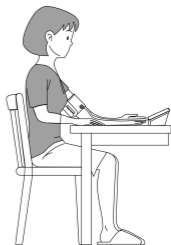

### **(4) Taking a measurement**

Start measurement after wearing the cuff:

Press the ON/OFF button and the monitor will begin to inflate. Please do not move or talk during the measurement. (The voice version will automatically broadcast the measured result during the measurement process.)



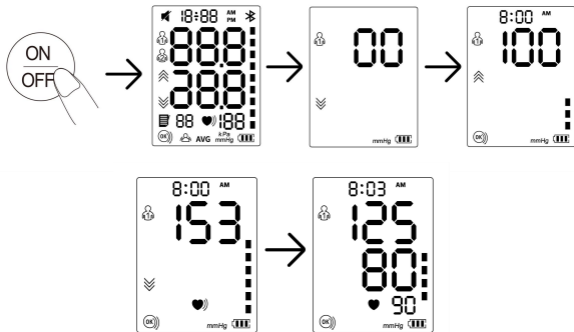

**Note:** If you feel uncomfortable during the measurement, press the ON/OFF button immediately to stop measure. When the air pressure is filled to a certain value, the value on the display screen will slowly drop at a certain speed, and the heartbeat symbol will flash. After the measurement is completed, the systolic pressure, diastolic pressure, and pulse measurements will be displayed on the screen.

**Note :** consult your doctor if unexpected readings are obtained.

### (5) Memory function

1) This monitor stores 99 sets of memories of two users.



After each measurement, the monitor will automatically store the measurement data. When the memory is full, the old measurement data will be overfilled with the new one.

2) In standby mode, press the MEM button once and the machine will display the average value of the blood pressure measured for the first three times. Press the MEM button again, the first memory will be displayed. Press the MEM button again and the rest memories will be displayed one by one.

### **(6) Delete memory**

Keep pressing the MEM button for 3 seconds to delete measurements stored on the device and the "  " icon will appear on the screen.

### **(7) Self check for cuff strap (Optional function)**

The "  " icon is always displayed on the screen when the cuff is worn correctly. When the cuff is worn too loosely, the "  " icon will always flash to remind you. If the "  " icon is flashing all the time, please press the " ON/OFF " button to stop the measurement.

### **(8) "Keep Still" indication (Optional function)**

The "  " icon flashes when the body moves during the measurement, which may cause incorrect measurement results. Please re-measure it.

## **11、Contraindications, Precautions, Warnings**

- DO NOT use this monitor on infants, toddlers, children or persons who cannot express themselves.
- DO NOT adjust medication based on readings from this blood pressure monitor. Take medication as prescribed by your physician. ONLY a physician is qualified to diagnose and treat high blood pressure.
- DO NOT use this monitor on an injured arm or an arm under medical treatment.
- DO NOT apply the arm cuff on your arm while on an intravenous drip or blood transfusion.
- DO NOT use this monitor in areas containing high frequency (HF) surgical equipment, magnetic resonance imaging (MRI) equipment, computerized tomography (CT) scanners. This may result in incorrect operation of the monitor and/or cause an inaccurate reading.
- DO NOT use this monitor in oxygen rich environments or near flammable gas.
- Consult with your physician before using this monitor if you have common arrhythmias such as atrial or ventricular premature beats or atrial fibrillation; arterial sclerosis; poor perfusion; diabetes; pregnancy; pre-eclampsia or renal disease. NOTE that any of these conditions in addition to patient motion, trembling, or shivering may affect the measurement reading.
- NEVER diagnose or treat yourself based on your readings.

ALWAYS consult with your physician.

- To help avoid strangulation, keep the air tube and type C cable away from infants, toddlers and children.
- This product contains small parts that may cause a choking hazard if swallowed by infants, toddlers and children.

Stop using this monitor and consult with your physician if you experience skin irritation or discomfort.

- Consult with your physician before using this monitor on an arm where intravascular access or therapy, or an arterio-venous (A-V) shunt, is present because of temporary interference to blood flow which could result in injury.
- Consult with your physician before using this monitor if you have had a mastectomy.
- Consult with your physician before using this monitor if you have severe blood flow problems or blood disorders as cuff inflation can cause bruising.
- DO NOT take measurements more often than necessary because bruising, due to blood flow interference, may occur.
- ONLY inflate the arm cuff when it is applied on your upper arm.
- Remove the arm cuff if it does not start deflating during a measurement.
- DO NOT use this monitor for any purpose other than measuring blood pressure.
- During measurement, make sure that no mobile device or

any other electrical device that emits electromagnetic fields is within 12 inches (30 cm) of this monitor. This may result in incorrect operation of the monitor and/or cause an inaccurate reading.

- DO NOT disassemble or attempt to repair this monitor or other components. This may cause an inaccurate reading.
- DO NOT use in a location where there is moisture or a risk of water splashing this monitor. This may damage this monitor.
- DO NOT use this monitor in a moving vehicle such as in a car.
- DO NOT drop or subject this monitor to strong shocks or vibrations.
- DO NOT use this monitor in places with high or low humidity or high or low temperatures.

## **12、 Common Q & A on Blood Pressure**

### **Q1. Why is the blood pressure measured at home lower than that measured in hospitals?**

1) Blood pressure measured at home is 20 mmHg-30 mmHg (2.7 kPa - 4.0 kPa) lower than that measured in hospitals. It is because people are nervous when measured in hospitals, while they tend to be in a stable mood when measured at home. It is important to understand the normal blood

pressure when you are at home.

2) If the cuff is placed in a position above the heart, the measured blood pressure is low, so please measure in the correct posture.

## **Q2. Why is the blood pressure measured at home higher than that measured in hospitals?**

1) The anti-hypertensive drugs lose the efficacy.

→Please accept the doctor's instruction.

2) The cuff is not twined correctly.

If the cuff position is wrong, no arterial signal will be caught, and the measured blood pressure value will be higher.

→Please confirm whether the cuff position is correct.

3) The cuff is rolled too loose.

If the cuff is rolled too loose, the compression force might fail to be transmitted to the artery, resulting that the measured blood pressure value is higher than the actual value.

→Adjust the gap between the arm and the cuff and tighten the cuff.

4) The posture is incorrect when measurement.

If bending down, sitting cross-legged or bending over the sofa or low table when measurement, the blood pressure might be increased due to the abdominal pressure or due to the arm position lower than the heart.

→ Please make measurement in correct posture.

#### **Q4. When will the measurement be better?**

Please make measurement in the morning after you get up to urinate or when your body and mood are in stable state. It is better to make measurement at the same time every day.

#### **Q5. Why the blood pressure value measured each time is different?**

1) When systole each time, the blood pressure will change to some extent. For example, a person with the pulse of 70 beats per minute will have 100,800 blood pressure changes every day. Because the blood pressure is constantly changing, it is difficult to obtain the correct blood pressure value by measurement only once. Please make measurement for 2~3 times. The first measurement will generally be higher due to nervousness or inadequate preparation, and then when the second measurement, the nervous emotion will be slightly alleviated, so generally, the second measurement will be 5mmHg-10mmHg (0.7kPa-1.3kPa) lower than the first time. This will be more obvious for those with higher blood pressure.

--When continuous measurement, please note that:

There might be extravasated blood because the arm is compressed, resulting that the finger tip blood does not flow smoothly, If you continue the measurement in case of extravasated blood, you cannot obtain the correct measured value. Loosen the arm band, raise your hand over the head,

and grasp and stretch your left and right palms for 15 times repeatedly. Then the extravasated blood can be dissolved, and you can continue the blood pressure measurement.

2) Cuff position and twining method. The measured value varies with the cuff size. Particularly, if the cuff is twined round the elbow, you cannot obtain the correct measured value.

--Please use the correct cuff twining method for measurement. The arm circumference range of the enclosed cuff is 22~32cm (center of the upper arm).If the model is inconsistent, please purchase separately.

### 13、Abnormal Phenomena and Handling

\* When the measurement is abnormal, the following symbols will appear. Please use the correct method for measurement.

| LCD display information | Reason / Meaning   |
|-------------------------|--|
| Er U                    | The inflation can not reach 30 mmHg in 12 seconds.                   |
| Er H                    | The inflation reaches 295mmHg, it deflates automatically after 20ms. |
| Er 1                    | The pulse rate is not detected correctly.                            |
| Er 2                    | Move, talk, or magnetic disturbance during a                         |



|      |                              |
|------|------------------------------|
|      | measurement.                 |
| Er 3 | The test result is abnormal. |

## \*Trouble shooting

| Abnormal phenomenon                                      | Reason   |
|--|--|
| Systolic pressure is high or diastolic is low            | <ol style="list-style-type: none"> <li>1. The arm cuff is applied too high.</li> <li>2. The arm cuff is not applied correctly.</li> <li>3. The arm cuff is applied too low.</li> <li>4. You move or talk during a measurement</li> </ol> |
| Blood pressure is too high or too low                    | The posture is not the same during each measurement.   |
| The measurement result varies with the one doctor takes. | The mental status changes when doctor takes a measurement, hence the result varies   |
| The measurement results are different every time         | Remain still for 4-5 minutes and take the measurement again  |

The screen cannot be displayed when press the ON/OFF key, or it cannot be displayed again after power on and fully displayed, or the symbol “  ” flashes during the test

The batteries are low, you need to change the batteries.

## 14、 Maintenance

### 14.1 Maintenance

To protect your monitor from damage, follow the directions below:

- Changes or modifications not approved by the manufacturer will void the user warranty.



#### **Caution**

- **DO NOT disassemble or attempt to repair this monitor or other components. This may cause an inaccurate reading.**

### 14.2 Storage

Keep your monitor and other components in the storage case when not in use.

Store your monitor and other components in a clean, safe location.

(1) **Remove the arm cuff from the monitor.**



• **To unplug the air plug, pull on the plastic air plug at the base of the tube, not the tube itself.**

(2) **Gently fold the air tube into the arm cuff.**

### **Note**

• Do not bend or crease the air tube excessively.

Do not store your monitor and other components:

- If your monitor and other components are wet.
- In locations exposed to extreme temperatures, humidity, direct sunlight, dust or corrosive vapors such as bleach.
- In locations exposed to vibrations or shocks.

### **14.3 Cleaning**

- Do not use any abrasive or volatile cleaners.
- Use a soft dry cloth or a soft cloth moistened with mild (neutral) detergent to clean your monitor and arm cuff and then wipe them with a dry cloth.

- Do not wash or immerse your monitor and arm cuff or other components in water.
- Do not use gasoline, thinners or similar solvents to clean your monitor and arm cuff or other components.

#### 14.4 Disposal

Dispose of your monitor, other components and optional accessories according to applicable local regulations. Unlawful disposal may cause environmental pollution.

### 15、Product Specification

|                  |   |                                  |
|------------------|---|----------------------------------|
| Product name     | Arm Blood Pressure Monitor                                  |                                  |
| Display mode     | Digital LCD display, 3 color backlight                      |                                  |
| Measuring method | Oscillometric Measurement                                   |                                  |
| Measuring part   | Upper arm   |                                  |
| Measuring range  | Blood Pressure value  | 0mmHg-295mmHg<br>(0kPa-39.33kPa) |
|                  | Pulse rate  | 40bpm-199bpm beats / minute      |
| Accuracy         | Pressure value  | ±3mmHg (±0.4kPa)                 |
|                  | Pulse rate  | ±5% of display value             |
| Low battery      | 4.6V±0.1V: low battery; <4.4V±0.1V: item will be turned off |                                  |
| Auto power-off   | 1 minute without operation                                  |                                  |
| Power source     | 4 AAA dry batteries or DC5V Type C cable                    |                                  |

|  |   |                           |
|--|---|---------------------------|
| Applied part                           | Type BF   |                           |
| Operation mode                         | Continuous operation  |                           |
| IP classification                      | IPX0  |                           |
| Item weight                            | About 262g±5g, (excluding batteries)  |                           |
| Dimension                              | 127mm(length)*93(width)* 73mm(height)   |                           |
| Screen size                            | 53mm(length)* 68mm( width) 3.4 inches   |                           |
| Cuff                                   | 22-32 cm  |                           |
| Service life                           | 5 years   |                           |
| Protection against electric shock      | Internally powered ME equipment (When using only batteries)<br>Class II ME equipment (AC adapter)   |                           |
| Working environment                    | Temperature condition   | 5℃-40℃                    |
|  | Humidity condition  | 15%-80%RH(non-condensing) |
|  | Atmospheric condition   | 80kPa-105k Pa             |
| Storage and transportation environment | Strong impact, direct collision, exposure to the sunlight or rain should be avoided during transportation.<br>Temperature from - 20 ℃ to 55 ℃ , relative humidity ≤ 93%(non-condensing), and atmospheric pressure ranging from 500 hPa to 1060 hPa, with no corrosive gas and positive ventilation. |                           |





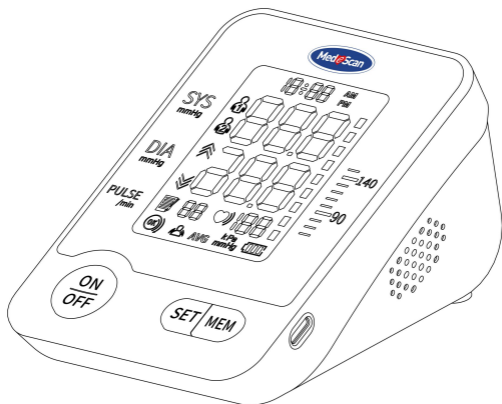

**Accuracy Obtains Joy and Health**