

Play Room Toys

Climbing Playseter >> Jungle GYM

Assembly Instruction Manual



Slider cum
Mountain
Climber



Jungle GYM
Assembly Instruction Manual

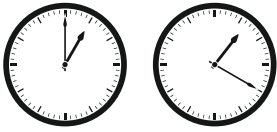

Assembly time : Approx 20 mins.

List of Items

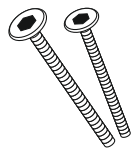

Allen screw
- 4 Nos.



Allen key
- 1 No.

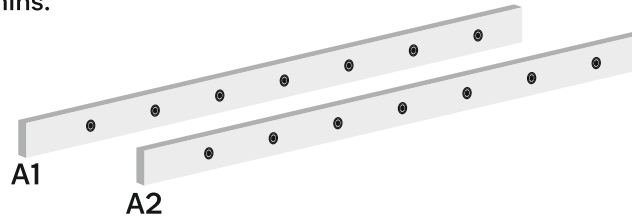

Monkey bar structure
side support - 2 Nos.



Monkey rods - 7 Nos.

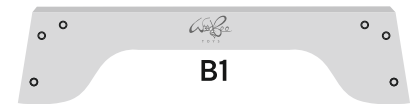

B1



B2

Face plate - 2 Nos.

(C1-C2)

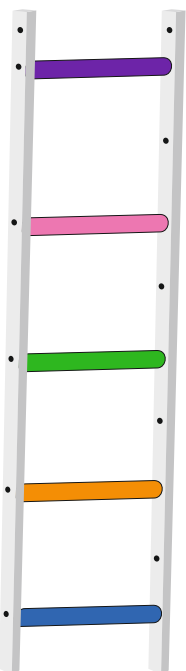

Step ladder and
side support - 2 Nos.

(C3-C4)

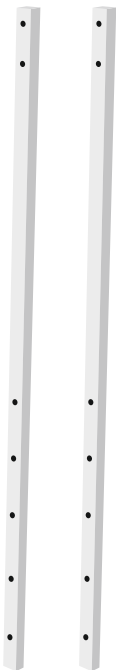

(D1-D2)

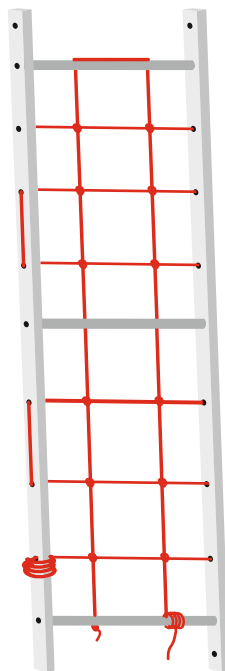

Rope climber structure
and side support - 1 No.

(D3)

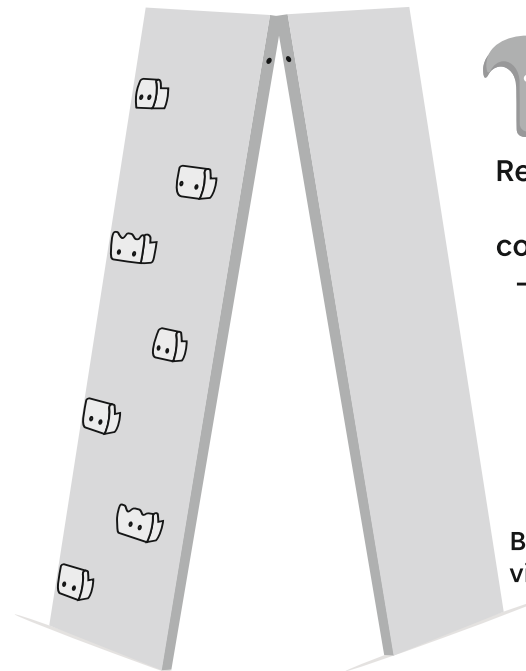

Reversible
slider
connector
- 2 Nos.

Back side
view of slider

Reversible slider cum
mountain climber



Beech wood rods
(short) - 4 Nos.



Beech wood rods
(long) - 8 Nos.

● Swing

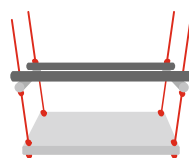

Also Including :-

● Gymnastic ring

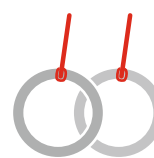

● Rope ladder

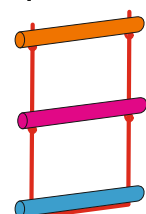

Please ensure availability of all materials listed before starting assembly.

Step 1

Fix the side supports of the monkey bar with beech wood rods.

- (i) Form the structure by fixing the (A1-A2) with 7 beech wood rods using allen screw.

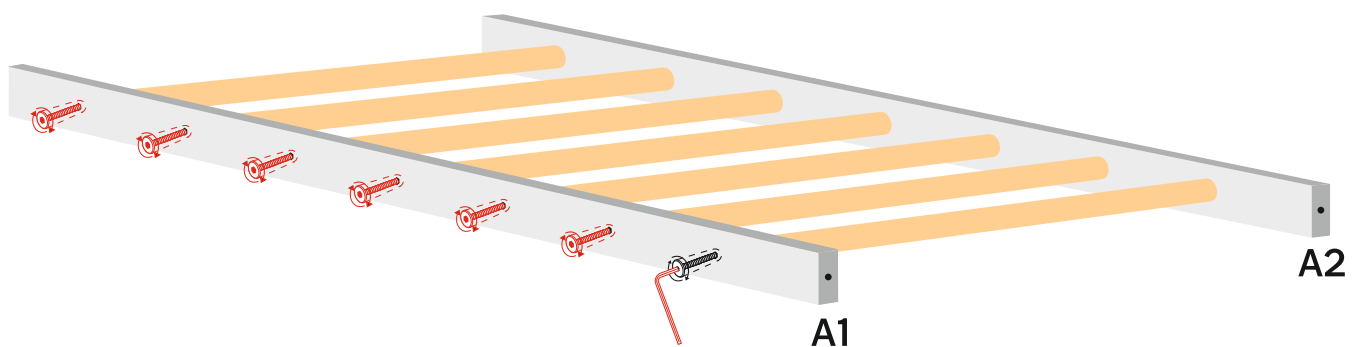
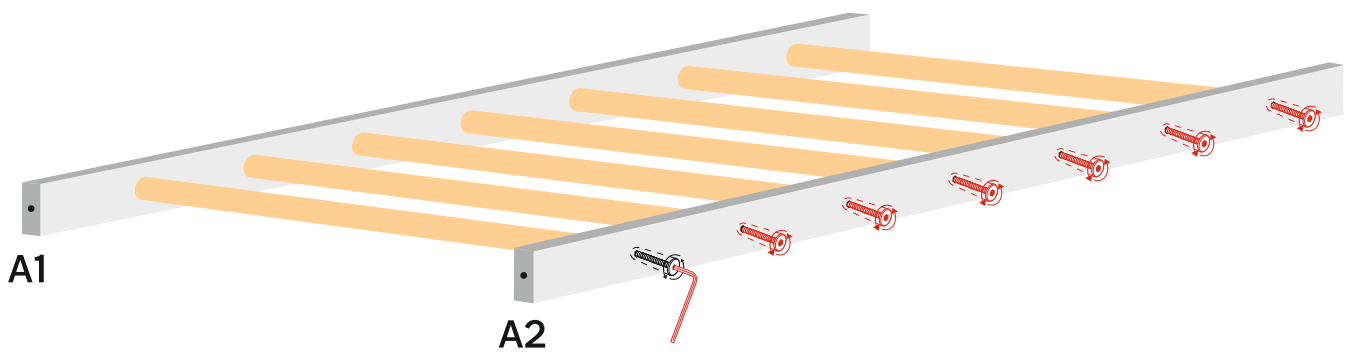

Step 2

Fix the face plate with the monkey bar.

- (i) Remove the screws from the face of the monkey bar and use it to fix the face plate with the monkey bar
- (ii) Screw it on the top two screw holes in the face plate B1 & B2

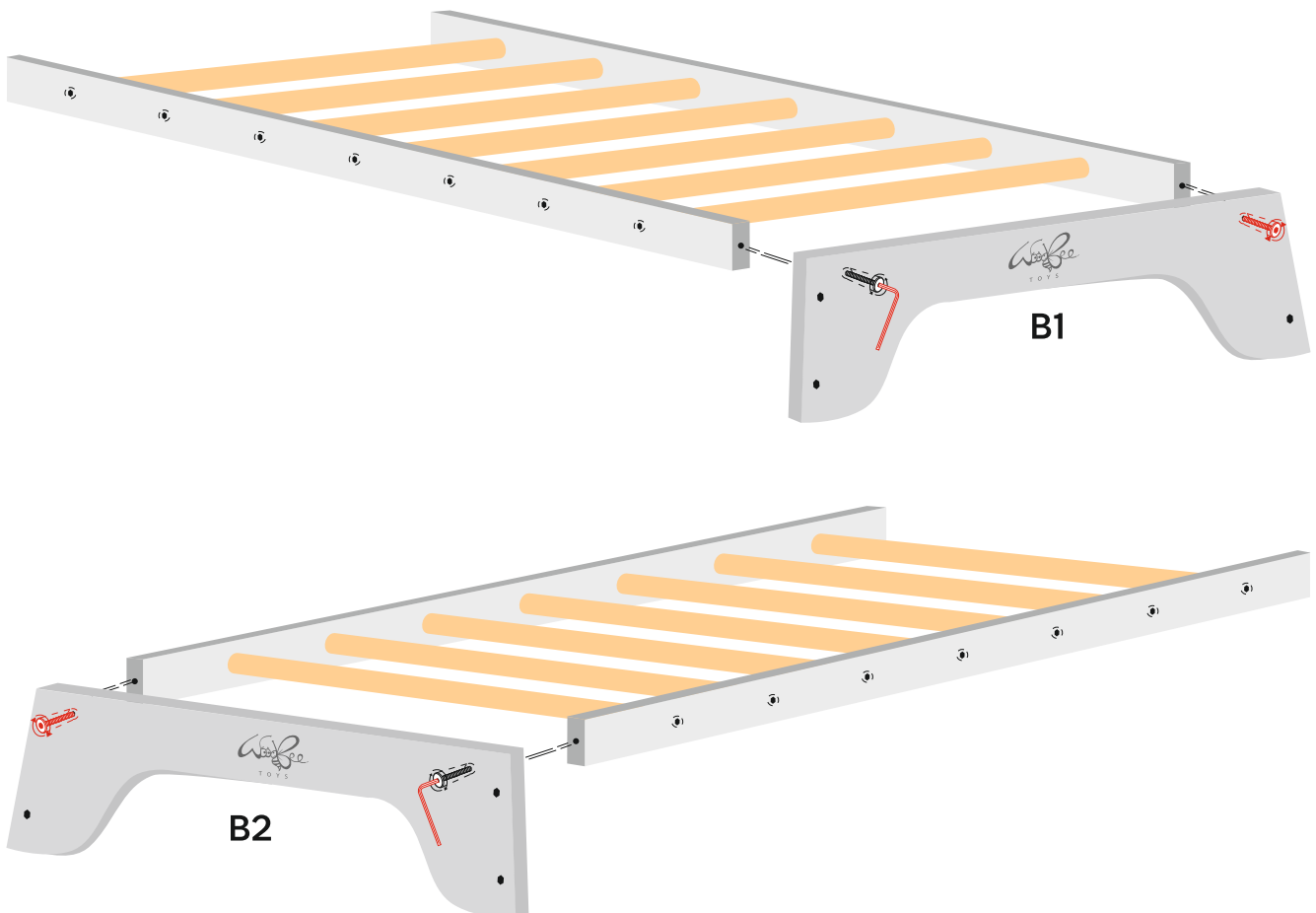



Step 3

Connect C3 with the provided C1-C2 structure by using the 4 short beech wood rods.

With this structure, connect C4 using the six long beech wood rods.

Please note : *

The screw on one side of the top beech wood rod will be bigger longer than other side screw. The bigger screw should be attached with the vertical support C4 on the top”

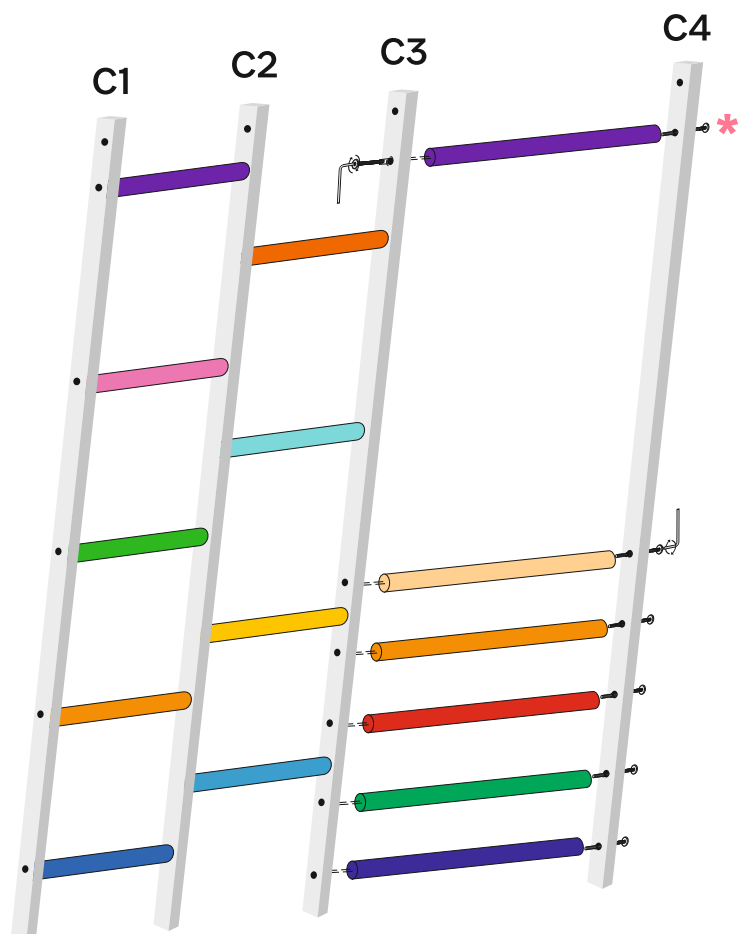
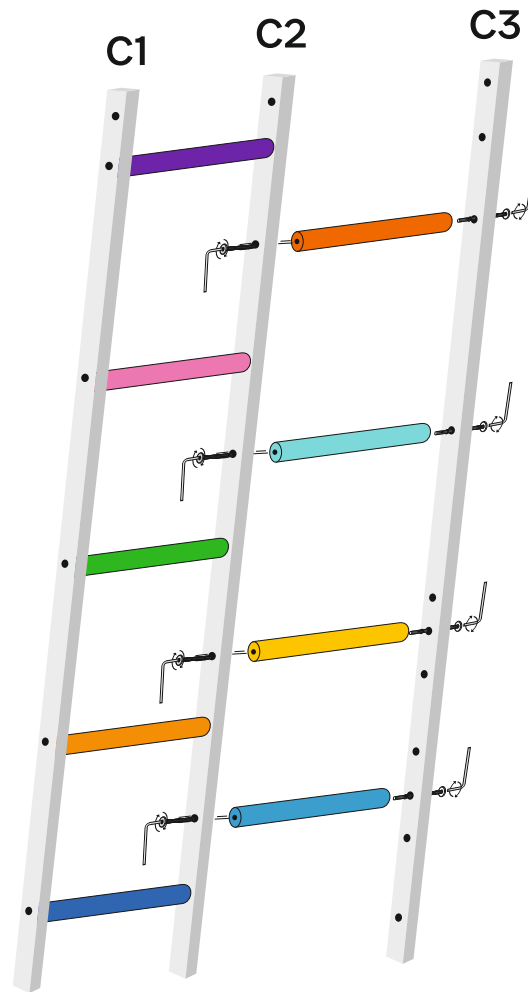

Step 4

With the rope climber structure connect D3 with long beech wood rods.

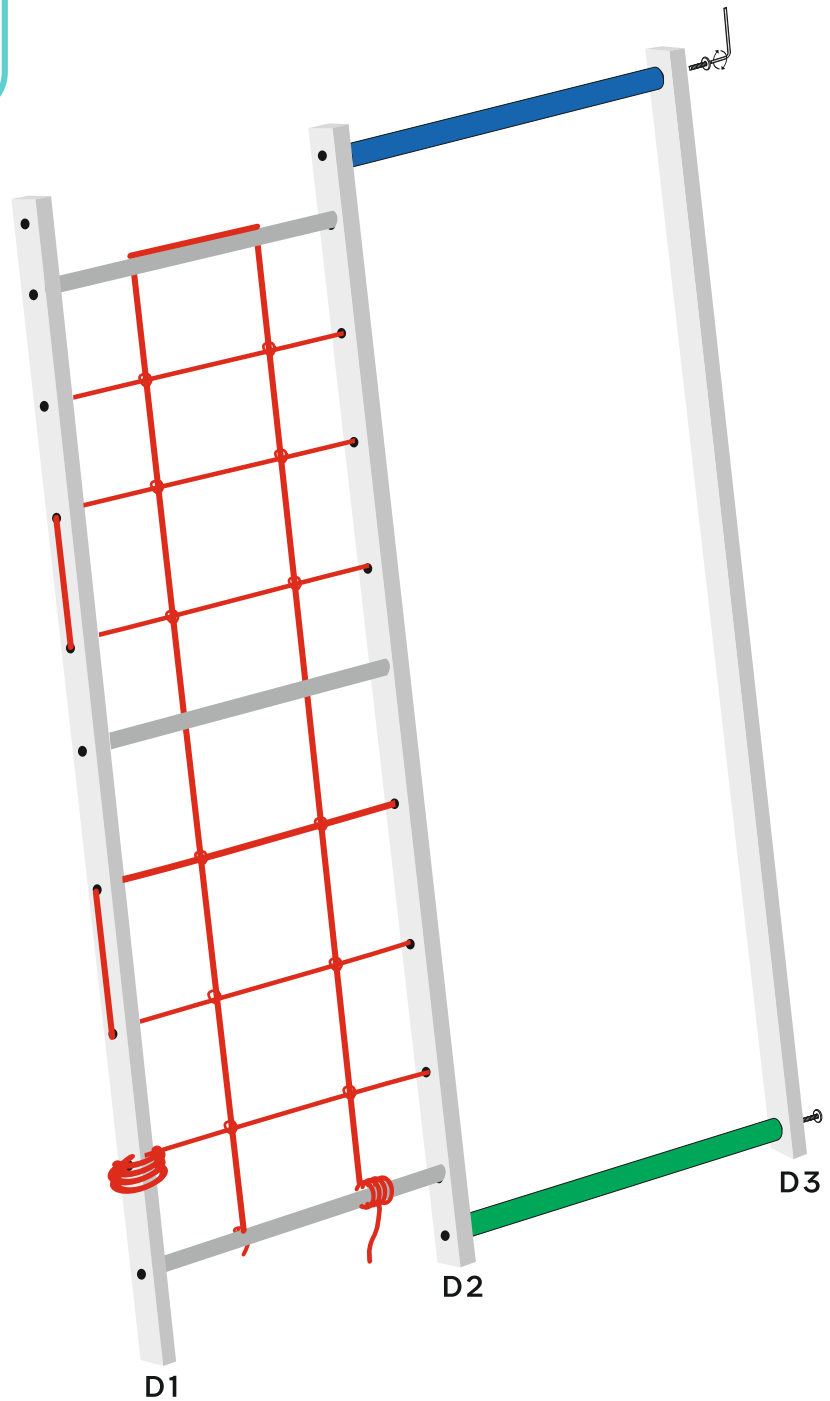

Jungle GYM
Assembly Instruction Manual

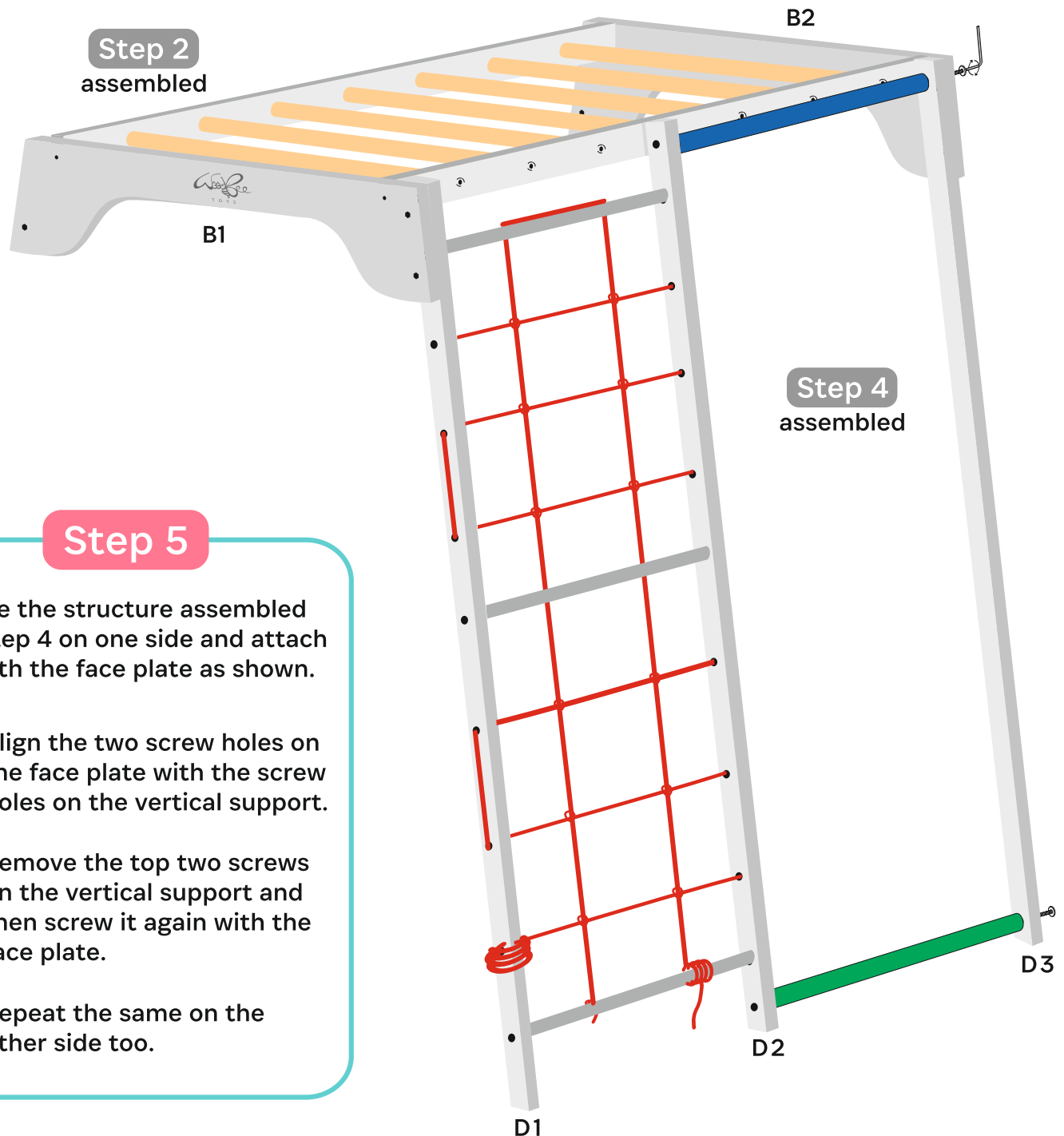

Jungle GYM
Assembly Instruction Manual

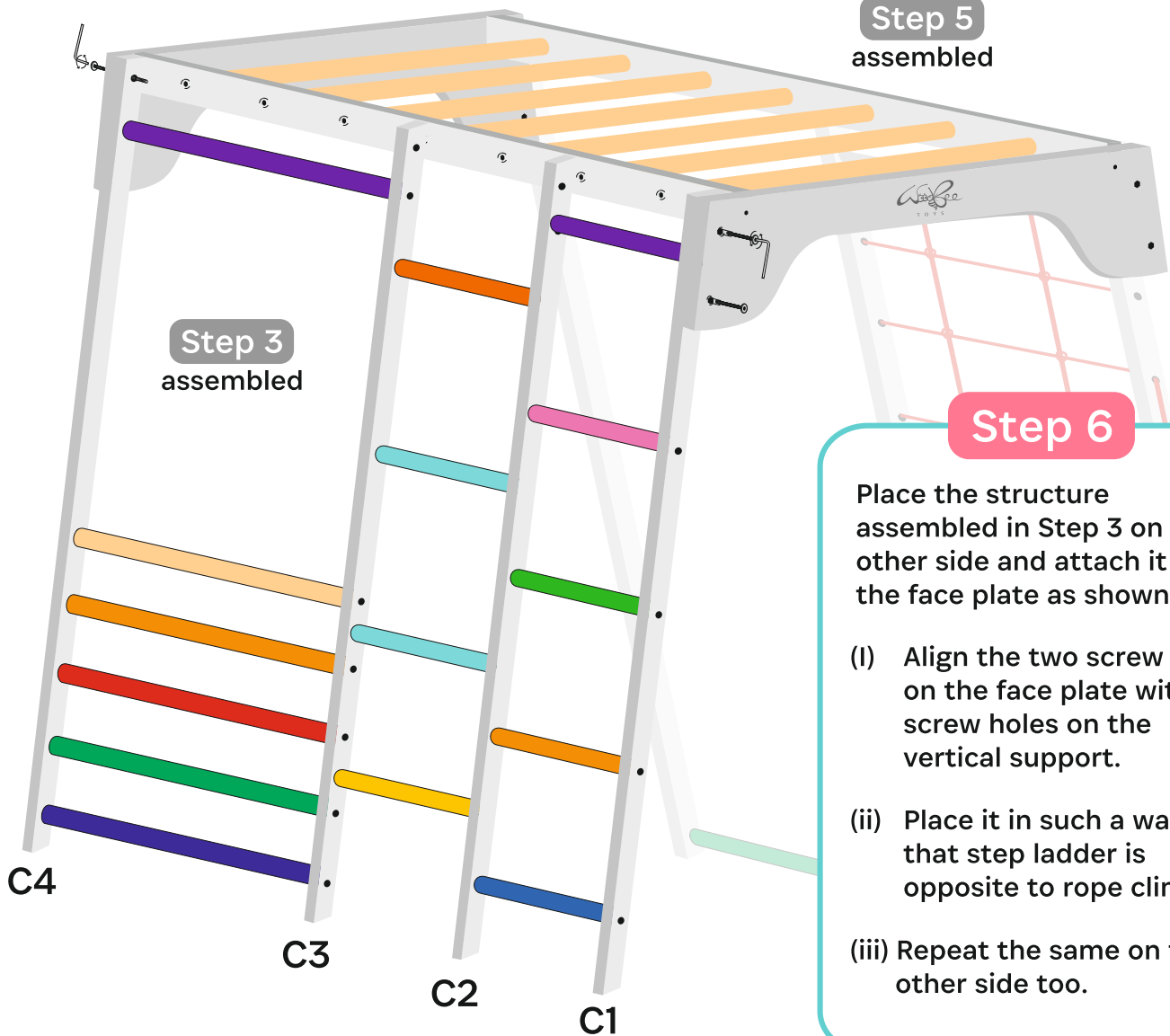

Place the structure assembled in Step 3 on the other side and attach it with the face plate as shown.

- (i) Align the two screw holes on the face plate with the screw holes on the vertical support.
- (ii) Place it in such a way that step ladder is opposite to rope climber
- (iii) Repeat the same on the other side too.

Step 7

Attach the mountain climber with the side support using connector screws provided.

Fix the mountain climber on the top rod of D2-D3

Reverse the mountain climber structure and hook it on to the C1-C2 rods to use it as a slider

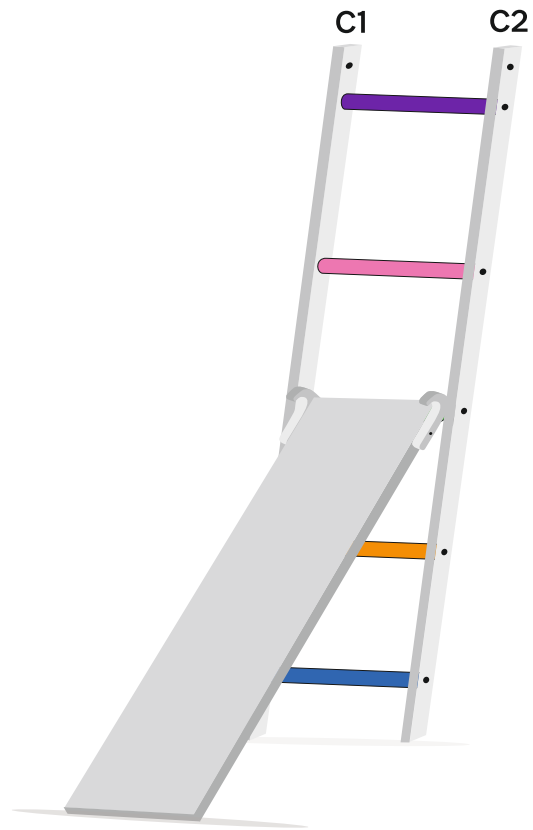
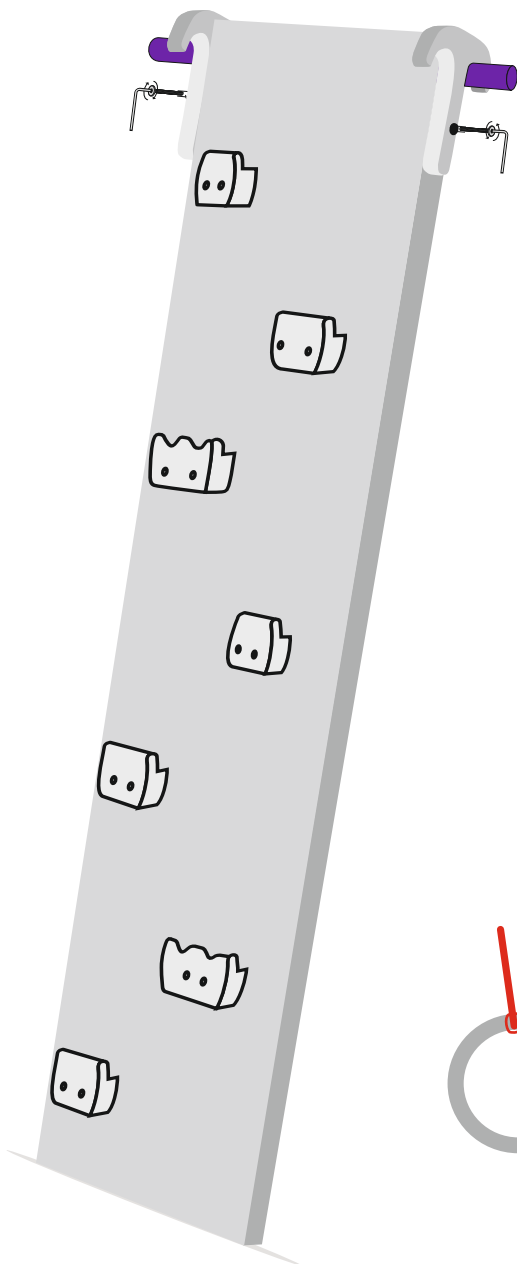

Step 8

Attach the swing, gymnastic ring and rope ladder on to the monkey bar.

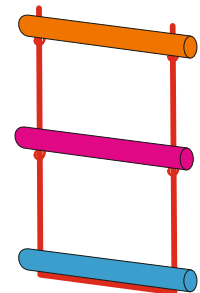
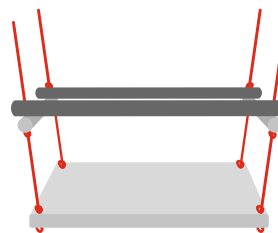
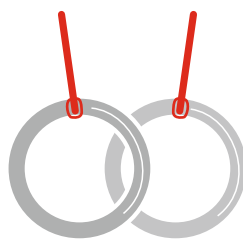

Now Ready to Play...