

Pure Sine Wave Inverter/Charger User's Manual(up to 15KW)

Version 5.2 (PN:50000-2018168)



Sigineer Power

Chinese Power Inverter
But Not As We Know It

Get The Perfect Inverter Chargers
For Your Business



Shenzhen Sigineer Power CO.,LTD.

Email: info@sigineer.com

TEL: +86 755 2160 7078

FAX: +86 755 6165 8278

Add: Bld A, Jiali Industrial Zone, Yuanfen Rd, Longhua, Shenzhen, 518100, China

Manufacturer Information

Table of Contents

1 Important Safety Information	3
1.1 General Safety Precautions	3
1.2 Precautions When Working with Batteries	3
2 Introduction.....	4
2.1 General Information.....	4
2.2 Application.....	5
2.3 Mechanical Drawing.....	6
2.4 Features	9
2.5 Electrical Performance	9
2.5.1 Invert	9
2.5.2 AC Charger	10
2.5.3 Transfer	13
2.5.4 Solar Charger (Optional).....	13
2.5.5 Power Saver	15
2.5.6 Protections.....	16
2.5.7 Remote control.....	16
2.5.8 LED Indicator & LCD	17
2.5.9 Audible Alarm.....	19
2.5.10 FAN Operation.....	19
2.5.11 DIP Switches	20
2.5.12 Auto Generator Start	22
2.5.13 Battery Temperature Sensing	23
2.5.14 Other Features	24
3 Installation.....	25
3.1 Location	25
3.2 DC Wiring Recommendation.....	25
3.3 AC Wiring Recommendation.....	27
3.4 Grounding	27
3.5 Mounting Flange.....	29
4 Maintenance & Troubleshooting	31
5 Warranty	33
Appendix 1 : High Power Inverter/Charger Spec Sheet	34
Appendix 2: Circuitry Scheme.....	36
Appendix 3: High Power Inverter/Charger System Wiring Diagram.....	37

Please record the Sigineer Power unit's model and serial number in case you need to provide this information in the future. It is much easier to record this information now than try to gather it after the unit has been installed.

Model Number: _____

Serial Number: _____

1 Important Safety Information

Save This Manual! Read this manual before installation, it contains important safety, installation and operating instructions. Keep it in a safe place for future reference.

All wiring must follow the National Electric Code, Provincial or other codes in effect at the time of installation, regardless of suggestions in this manual. All wires should be copper conductors.

1.1 General Safety Precautions

1.1.1 Before installing and using the High Power Pure Sine Wave Inverter/Charger, read the manual and cautionary markings on the Inverter/Charger enclosure. Be sure to read all instructions and cautionary markings for any equipment attached to this unit. Installers must be certified technicians or electricians.

1.1.2 This product is designed for indoor/compartment installation. Do not expose the inverter/charger to rain, snow, spray, bilge or dust. To reduce risk of hazard, do not cover or obstruct the ventilation openings. Do not install the inverter/charger in a zero-clearance compartment. Overheating may result. Allow at least 30CM (11.81 inches) of clearance around the inverter for air flow. Make sure that the air can circulate freely around the unit. A minimum air flow of 145CFM is required.

1.1.3 To avoid a risk of fire and electronic shock. Make sure that existing wiring is in good electrical condition; and that wire size is not undersized. Do not operate the Inverter with damaged or substandard wiring.

1.1.4 This equipment contains components which can produce arcs or sparks. To prevent fire or explosion do not install in compartments containing batteries or flammable materials or in locations which require ignition protected equipment. This includes any space containing gasoline-powered machinery, fuel tanks, or joints, fittings, or other connection between components of the fuel system. See Warranty for instructions on obtaining service.

1.1.5 Do not dis-assemble the Inverter/Charger. It contains no user serviceable parts. Attempting to service the Inverter/Charger yourself may result in a risk of electrical shock or fire. Internal capacitors remain charged after all power is disconnected.

1.1.6 To reduce the risk of electrical shock, disconnect both AC and DC power from the Inverter/Charger before attempting any maintenance or cleaning. Turning off controls will not reduce this risk

CAUTION: Equipment damage

The output side of the inverter's AC wiring should at no time be connected to public power or a generator. This condition is far worse than a short circuit. If the unit survives this condition, it will shut down until corrections are made.

Installation should ensure that the inverter's AC output is, at no time, connected to its AC input.

WARNING: LIMITATIONS ON USE

SPECIFICALLY, PLEASE NOTE THAT THE INVERTER/CHARGER SHOULD NOT BE USED IN CONNECTION WITH LIFE SUPPORT SYSTEMS OR OTHER MEDICAL EQUIPMENT OR DEVICES. WE MAKES NO WARRANTY OR REPRESENTATION IN CONNECTION WITH THEIR PRODUCTS FOR SUCH USES. USING THE INVERTER/CHARGER WITH THESE PARTICULAR EQUIPMENTS IS AT YOUR OWN RISK.

1.2 Precautions When Working with Batteries

- 1.2.1 If battery acid contacts skin or clothing, wash immediately with soap and water. If acid enters eye, immediately flood eye with running cold water for at least 20 minutes and get medical attention immediately.
- 1.2.2 Never smoke or allow a spark or flame in vicinity of battery or engine.
- 1.2.3 Do not drop a metal tool on the battery. The resulting spark or short-circuit on the battery of other electrical part may cause an explosion.
- 1.2.4. Remove personal metal items such as rings, bracelets, necklaces, and watches when working with a lead-acid battery. A lead-acid battery produces a short-circuit current high enough to weld a ring or the like to metal, causing a severe burn.
- 1.2.5 To reduce the risk of injury, charge only rechargeable batteries such as deep-cycle lead acid, lead antimony, lead calcium gel cell, absorbed mat, NiCad/NiFe or Lithium battery. Other types of batteries may burst, causing personal injury and damage.
- 1.2.6 Don't install the inverter near batteries, the inverter may heat battery electrolyte and cause corrosive fumes to vent and damage/corrode nearby electronics or metals.

2 Introduction

2.1 General Information

Thank you for purchasing the High Power Pure Sine Wave Inverter/Charger.

The High Power Pure Sine Wave Inverter/Charger is a transformer based inverter and battery charger with an unprecedented conversion efficiency of 90%.

Packed with unique features, it is one of the most technically advanced inverter/charger on the market.

It features power factor corrected, sophisticated multi-stage charging control and pure sine wave output with high surge capability to meet power needs of all sorts of demanding loads without putting the equipment at risk.

The transformers of the whole line have been consistently improved for years to achieve the best balance of conversion efficiency, idle consumption and maximum THD.

The idle consumption of the High Power is ultra low, roughly 1.5% of its rated power.

Loaded with full linear loads, the maximum THD of the High Power is 3% at nominal battery voltage and 10% at low battery voltage alarm point.

These special features make this line compete very well with its high frequency counterparts.

The powerful battery charger of High Power Inverter/Charger goes as high as 120Amps (varies on different models). In respond to the increasing demand of more advanced battery charging, our engineering team equipped the line with Battery Temperature Sensing for increased charging precision.

The generous 300% surge capacity of 20 seconds makes it possible to support demanding inductive loads.

The High Power models are available in 120Vac(single phase), 230Vac(single phase) and 120/230Vac(split phase), together with a manual 50Hz/60Hz frequency switch, the product line is compatible with all the major utility standards worldwide.

This line includes some exclusive 4KW 12Vdc and 6KW 120Vac models which have been unheard of before in the industry.

The 4KW 12Vdc ones enable vehicle users to power ample loads at a 12VDC battery bank without reconfiguration of their battery bank.

While the 6KW 120Vac ones allow users to get the full 6KW power at 120Vac without going to 230Vac split phase.

The AC/Battery priority, auto generator start functionality and optional built-in solar charger make it ideally suitable to work in either backup power or renewable energy applications.

When customized to Battery priority mode via a DIP switch, the inverter will extract maximum power from external power sources in renewable energy systems and a minimal cycle of battery will be required. With the availability of auto generator start, an electrical generator can be integrated into the system and started when the battery voltage goes low.

With audible buzzer and a LCD display, the inverter gives the users comprehensive information of the operation status, making it easier for maintenance and troubleshooting.

Thus the High Power Pure Sine Wave Inverter/Charger is suitable for a myriad of applications including renewable energy systems, utility, truck, RV and emergency vehicles etc.

To get the most out of the power inverter, it must be installed, used and maintained properly. Please read the instructions in this manual before installing and operating.

2.2 Application

Power tools—circular saws, drills, grinders, sanders, buffers, weed and hedge trimmers, air compressors.

Office equipment – computers, printers, monitors, facsimile machines, scanners.

Household items – vacuum cleaners, fans, fluorescent and incandescent lights, shavers, sewing machines.

Kitchen appliances – coffee makers, blenders, ice makers, toasters.

Industrial equipment – metal halide lamp, high – pressure sodium lamp.

Home entertainment electronics – television, VCRs, video games, stereos, musical instruments.

2.3 Mechanical Drawing



DC SIDE FOR 1KW 1.5KW MODELS

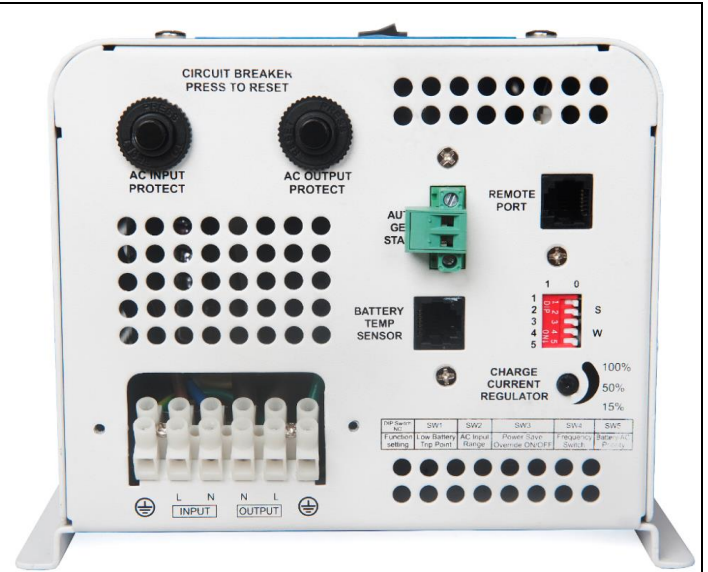

AC DIDE FOR 1KW TO 1.5KW MODELS

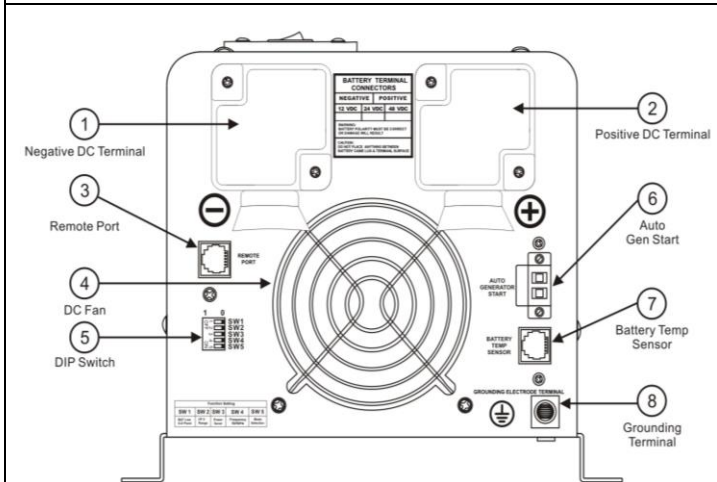

DC SIDE FOR 2KW TO 6KW MODELS

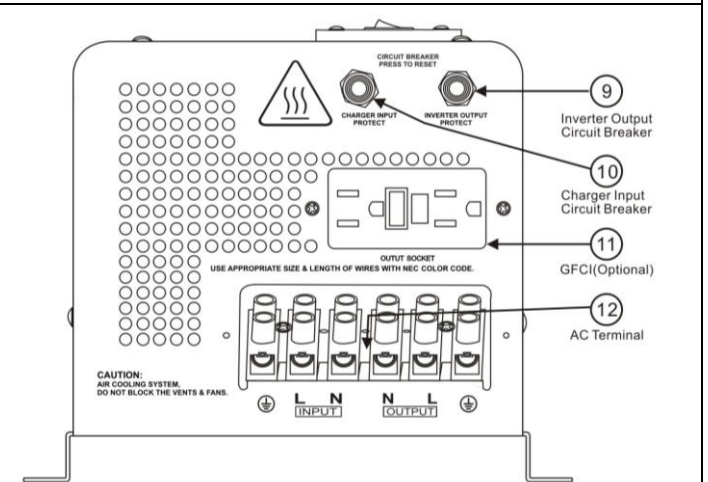

AC DIDE FOR 2KW TO 3KW MODELS

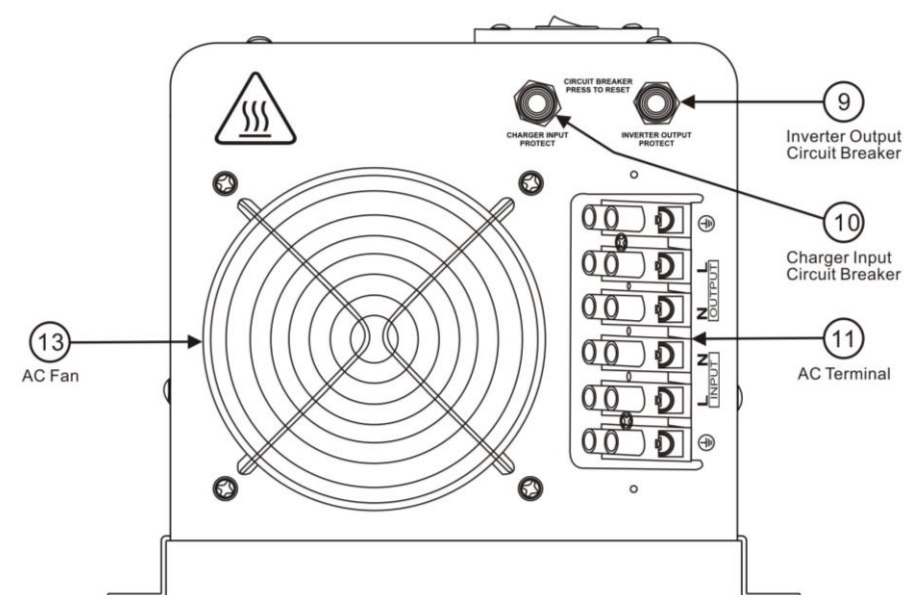

AC DIDE FOR 4KW TO 6KW MODELS

For 8KW 10KW 12KW & 15KW

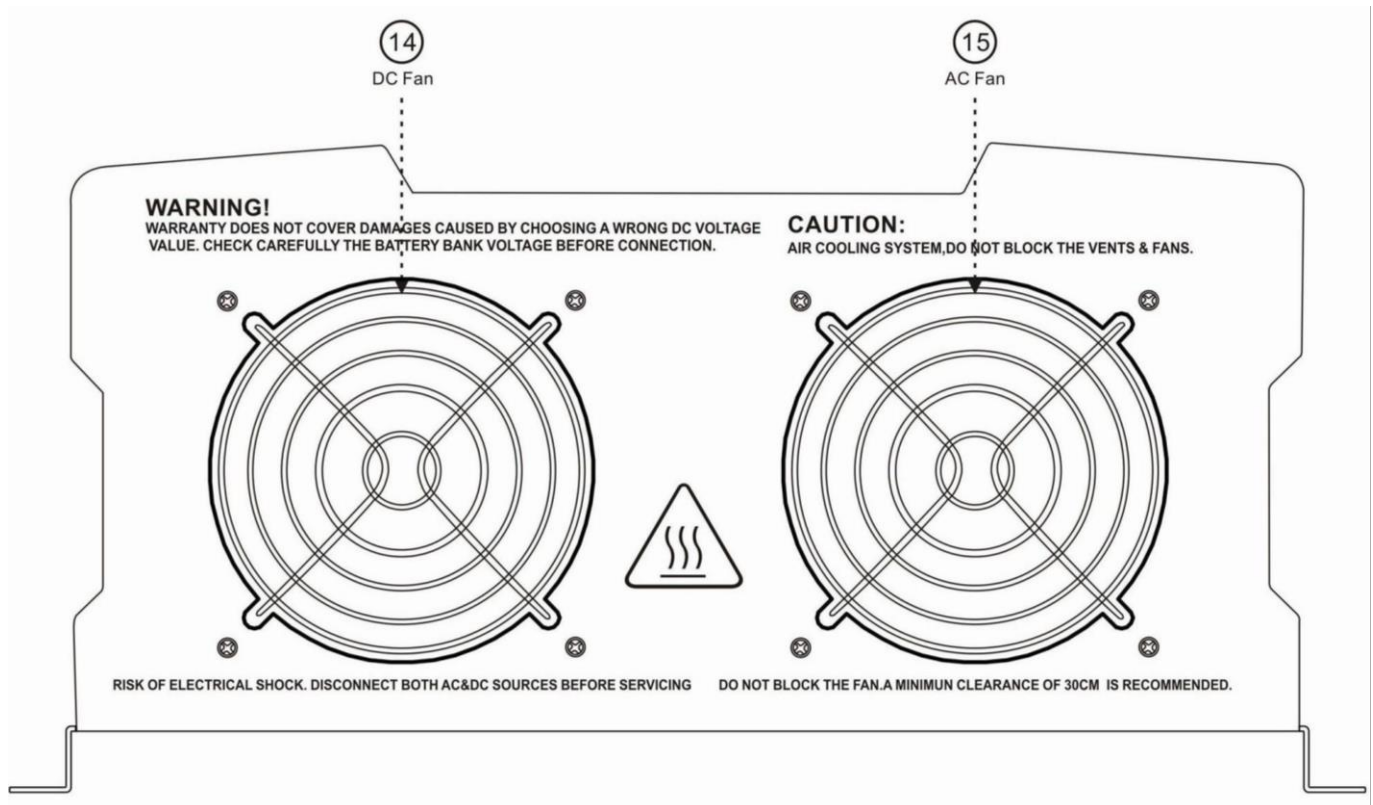

For 8KW 10KW 12KW & 15KW

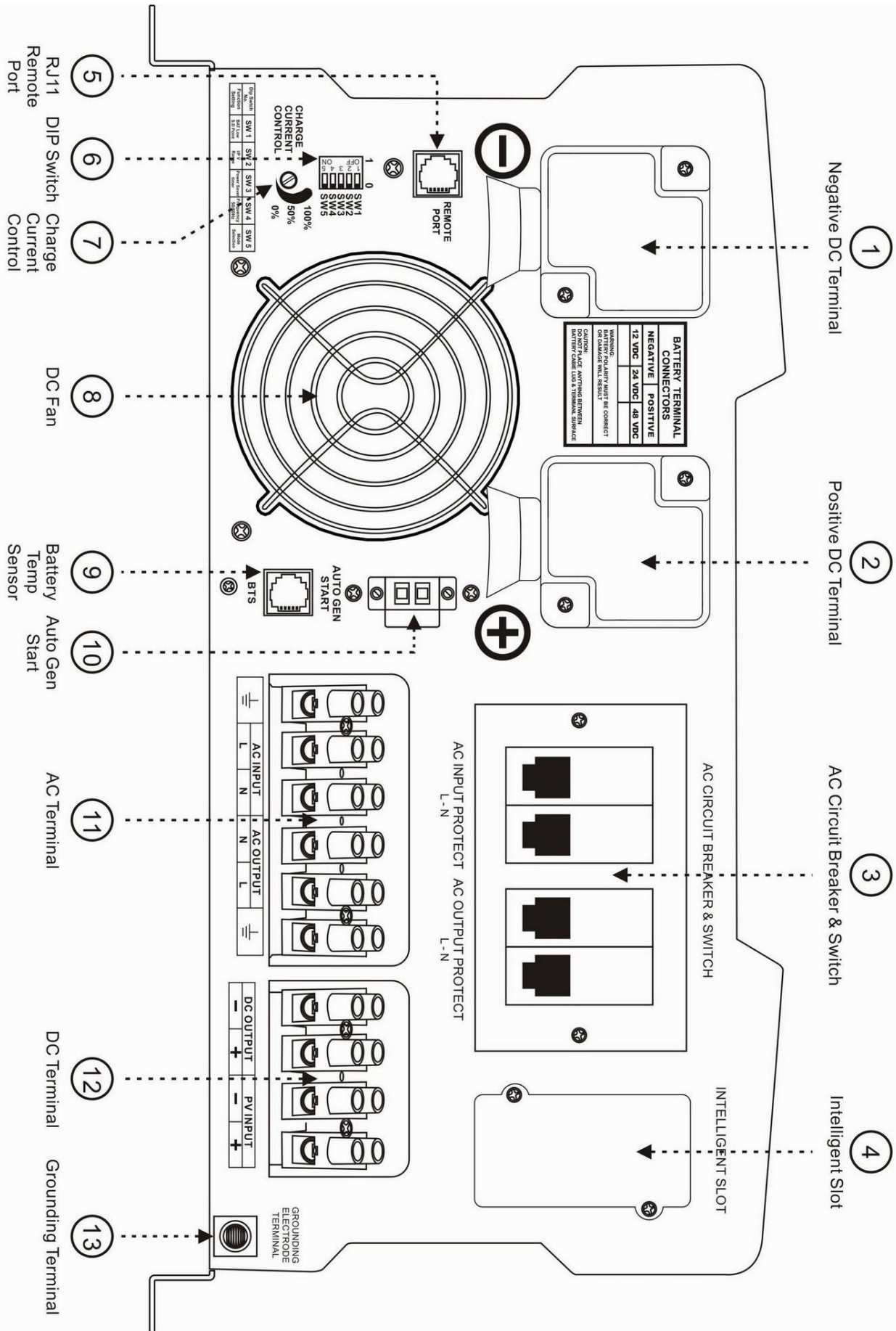

2.4 Features

Auto Generator Start

Battery Temperature Sensing for increased charging precision

Manual 50Hz/60Hz output frequency switch for worldwide operation

Maximum THD: 3% at nominal battery voltage

Maximum 90% conversion efficiency

Exclusive 4KW 12Vdc and 6KW 120Vac models

Powerful 4-stage power factor corrected battery charger up to 120 Amps, settable from 0%-100%

High surge output capability, 300% peak load for 20 seconds

Fully isolated AC output from battery input

Ultra low quiescent current, low power 'Power Saver Mode' to conserve energy

Battery type selector for 8 type of batteries and de-sulphation for completely drained batteries

10 ms transfer time from AC to battery for continuous load operation

Smart remote control with optional LCD display

15 sec DC to AC transfer delay, improved protection for generator driven loads

Thermally controlled variable speed fan for more efficient cooling

Extensive protections against various harsh situations

New functionality (Battery priority mode and Low battery recover) developed for renewable energy systems

2.5 Electrical Performance

2.5.1 Invert

Topology

The High Power pure sine wave inverter/charger is built according to the following topology.

Invert: Full Bridge Topology.

Charge: Isolated Boost Topology

When operating in invert mode, the direct current (DC) that enters the inverter from the batteries is filtered by a large input capacitor and switched "On" and "Off" by the Metal Oxide Silicon Field Effect Transistors (MOSFET) at a rate of 50 Hz or 60Hz, and directed into the transformer which steps the voltage up to 230 or 120 volts. The unit has a 16bit, 4.9MHZ microprocessor to control the output voltage and frequency as the DC input voltage and/or output load varies.

Because of high efficiency MOSFETs and the heavy transformers, it outputs PURE SINE WAVE AC with an average THD of 7% (min 3%, max 10% under full linear loads) depending on load connected and battery voltage.

The peak invert efficiency of High Power is 90%.

Overload Capacity

The High Power inverter/charger has different overload capacities, making it ideal to handle demanding loads.

1 For 110% < Load < 125% ($\pm 10\%$), no audible alarm in 14 minutes, beeps 0.5s every 1s in the 15th minute, and Fault(Turn off) after the 15th minute.

2 For 125% < Load < 150% ($\pm 10\%$), beeps 0.5s every 1s and Fault(Turn off) after the 1 minute.

3 For $300\% \cong \text{Load} > 150\% (\pm 10\%)$, beeps 0.5s every 1s and Fault(Turn off) after 20s.

Soft Start in Inverter Mode

The inverter is engineered with “Soft Start” feature.

When the inverter is turned on, the output voltage gradually ramps up from 0VAC to rated voltage in about 1.2 sec. This effectively reduces otherwise very high starting inrush current drawn by AC loads such as Switched Mode Power Supplies and inductive loads. This will result in lower motor inrush current, which means less impact on the loads and inverter.

Caution:

After the inverter is switched on, it takes a finite time for it to self diagnose and get ready to deliver full power. Hence, always switch on the load(s) after a few seconds of switching on the inverter. Avoid switching on the inverter with the load already switched on. This may prematurely trigger the overload protection. When a load is switched on, it may require initial higher power surge to start. Hence, if multiple loads are being powered, they should be switched on one by one so that the inverter is not overloaded by the higher starting surge if all the loads are switched on at once.

2.5.2 AC Charger

The High Power pure sine wave inverter/charger is equipped with an active PFC (Power Factor Corrected) multistage battery charger. The PFC feature is used to control the amount of power used to charge the batteries in order to obtain a power factor as close as possible to 1.

Unlike other inverters whose max charging current decreases according to the input AC voltage, High Power pure sine wave inverter/charger is able to output max charge current as long as input AC voltage is in the range of 164-243VAC(95-127VAC for 120V model), and AC freq is in the range of 48-54Hz(58-64Hz for 60Hz model).

The High Power pure sine wave inverter/charger has a very rapid charge current available, and the max charge current can be adjusted from 0%-100% via a liner switch on the DC side of the inverter. This will be helpful if this powerful charger apply charging on a small capacity battery bank.

Choosing “0” in the battery type selector will disable charging function.

There are three main charging stages:

Bulk Charging: This is the initial stage of charging. While Bulk Charging, the charger supplies the battery with controlled constant current. The charger will remain in Bulk charge until the Absorption charge voltage (determined by the Battery Type selection) is achieved.

Software timer will measure the time from charger start until the battery charger reaches 0.3V below the boost voltage, then take this time as T_0 and $T_0 \times 10 = T_1$.

Absorb Charging: This is the second charging stage and begins after the absorb voltage has been reached. Absorb Charging provides the batteries with a constant voltage and reduces the DC charging current in order to maintain the absorb voltage setting.

In this period, the inverter will start a T_1 timer; the charger will keep the boost voltage in Boost CV mode until the T_1 timer has run out. Then drop the voltage down to the float voltage. The timer has a minimum time of 1 hour and a maximum time of 12 hours.

Float Charging: The third charging stage occurs at the end of the Absorb Charging time. While Float charging, the charge voltage is reduced to the float charge voltage (determined by the Battery Type selection*). In this stage, the batteries are kept fully charged and ready if needed by the inverter.

If the A/C is reconnected or the battery voltage drops below 12Vdc/24Vdc/48Vdc, the charger will reset the

cycle above.

If the charge maintains the float state for 10 days, the charger will deliberately reset the cycle to protect the battery.

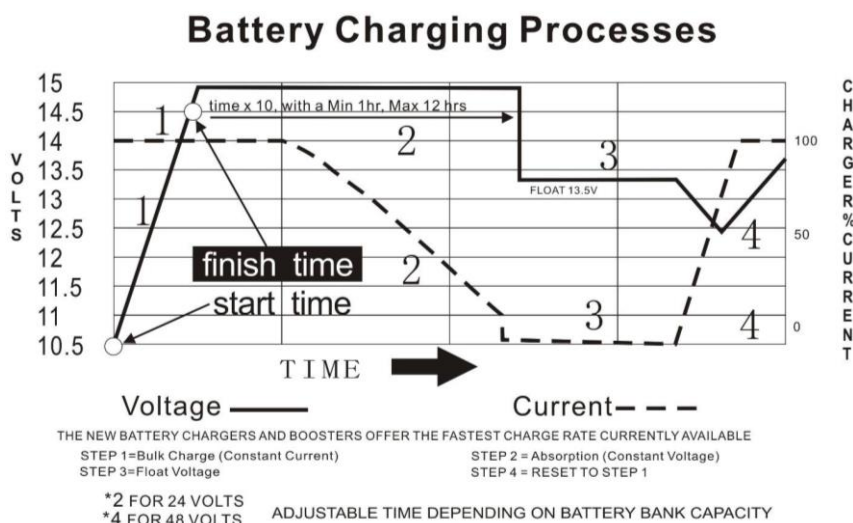

De-sulphation

The de-sulphation cycle on switch position 8 is marked in red because this is a very dangerous setting if you do not know what you are doing. Before ever attempting to use this cycle you must clearly understand what it does and when and how you would use it.

What causes sulphation? This can occur with infrequent use of the batteries, nor if the batteries have been left discharged so low that they will not accept a charge. As the saying goes, desperate diseases must have desperate remedies. This cycle is a very high voltage charge cycle especially designed to try to break down the sulphated crust that is preventing the plates from taking a charge and thus allow the plates to clean up and accept a charge once again.



Warning!

The de-sulphation charging should not be carried out on batteries with good conditions.

Battery type selector			
Switch setting	Description	Boost / Vdc	Float / Vdc
0	Charger Off		
1	Gel USA	14.0	13.7
2	AGM 1	14.1	13.4
3	AGM 2 / Lithium Battery	14.6	13.7
4	Sealed lead acid	14.4	13.6
5	Gel EURO	14.4	13.8
6	Open lead acid	14.8	13.3
7	Calcium	15.1	13.6
8	De sulphation	15.5 (4 Hours then Off)	
9	EV Battery	Customized	Customized
12Vdc Mode (*2 for 24Vdc ; *4 for 48Vdc)			

For Sigineer Power's APC6048D, HP12048D, HP15048D Inverter chargers, the battery type selector position of "9" is customized with special charging algorithm for lithium battery from EV.

The user must also put the DIP SW5 switch to "Battery Priority" to activate this setting..

The algorithm has only Bulk Charging (Constant Current) to charge the battery, when the battery is charged to 50.5Vdc, the charger will shut off and inverter goes to battery mode.

Low Battery Cut Off: 36Vdc

Low Battery Voltage Alarm/ Charger Activation: 37Vdc

Low Battery Cut Off Recovery: 47Vdc.

High Battery Voltage Alarm/ Charger Cut Off: 50.5Vdc

High Battery Cut Off: 51Vdc

Warning: The 12KW unit will be de-rated to 10KW and 15KW will be de-rated to 12KW when voltage drops below 40Vdc.

Charging depleted batteries

The High Power pure sine wave inverter/charger allows start up and through power with depleted batteries. For 12VDC models, after the battery voltage goes below 10V, if the switch is still (and always) kept in "ON" position, the inverter is always connected with battery whose voltage doesn't drop below 2V, the inverter will be able to charge the battery once qualified AC inputs.

Before the battery voltage going below 9VDC, the charging can activated when the switch is turned to "Off", then to "ON".

When the voltage goes below 9VDC, and the power switch is turned to "OFF" or disconnect the inverter from battery, the inverter will not be able to charge the battery once again, because the CPU lose memory during this process.

Charging current for each model

Model Wattage	Battery Voltage	Charging Current	Model Wattage	Battery Voltage	Charging Current
1KW	12 Vdc	35±5 Amp	2KW	12 Vdc	60±5 Amp
1KW	24 Vdc	20±5 Amp	2KW	24 Vdc	30±5 Amp
1.5KW	12 Vdc	45±5 Amp	2KW	48 Vdc	15±5 Amp
1.5KW	24 Vdc	25±5 Amp	4KW	12 Vdc	100±5 Amp
3KW	12 Vdc	80±5 Amp	4KW	24 Vdc	55±5 Amp
3KW	24 Vdc	45±5 Amp	4KW	48 Vdc	35±5 Amp
3KW	48 Vdc	25±5 Amp	6KW	24 Vdc	80±5 Amp
5KW	24 Vdc	65±5 Amp	6KW	48 Vdc	50±5 Amp
5KW	48 Vdc	40±5 Amp	10KW	24 Vdc	120±5 Amp
8KW	24 Vdc	100±5 Amp	10KW	48 Vdc	80±5 Amp
8KW	48 Vdc	65±5 Amp	12KW	48 Vdc	120±5 Amp
			15KW	48 Vdc	120±5 Amp

The charging capacity will go to peak in around 3 seconds, this may probably cause a generator to drop frequency, making inverter transfer to battery mode.

It is suggested to gradually put charging load on the generator by switching the charging switch from min to max, together with the 15s switch delay, our inverter gives the generator enough time to spin up.

Changing max charging current

The battery type selector position of "0" will disable battery charger.

The "Charge Current Control" knob will enable the user to control the max charging current from 15% to maximum.



Please use a small jeweler's style flat-head screwdriver to turn the charge current control switch gently to avoid breakage due to over-turning.

To guarantee the best performance of AC charger when the AC input is from a

Caution:	<p>generator, the standby generator should be of at least 150% higher capacity than the inverter.</p> <p>Warning! Operation with an under-rated generator or generator with unqualified wave form may cause premature failure which is not under warranty.</p>
-----------------	---

2.5.3 Transfer

While in the Standby Mode, the AC input of the inverter is continually monitored. Whenever AC power falls out of the trip voltages, the inverter automatically transfers back to the Invert Mode with minimum interruption to your appliances.

The transfer from Standby mode to Inverter mode occurs in approximately 6 milliseconds, with the worst case of 10 milliseconds. And it is the same time from Inverter mode to Standby mode.

Though it is not designed as a computer UPS system, this transfer time is usually fast enough to hold them up as devices like computers can generally tolerate a max power loss of 20ms.

There is a 15-second delay from the time the inverter senses that continuously qualified AC is present at the input terminals to when the transfer is made. This delay is built in to provide time for a generator to spin-up to a stable voltage and avoid relay chattering. The inverter will not transfer to generator until it has locked onto the generator's output. This delay is also designed to avoid frequent switch when input utility is unstable.

2.5.4 Solar Charger (Optional)

The High Power pure sine wave inverter/charger can be built with optional MPPT solar charging modules up to two pcs.

Listed below is the spec of solar charger.

Table 1 Electrical Specifications @ 25°C (77°F)

Rated Battery Voltage	12Vdc	24Vdc	48Vdc
Rated Charge Current (Includes Load Current)	60 Amp	40Amp	40Amp
MAX DC Load Current	10Amp		
Input Voltage Range	15-45Vdc	30-100Vdc	60-100Vdc
Max. PV Open Circuit Array Voltage	45Vdc	100Vdc	100Vdc
Overload Protection (DC load)	2.0 * Inom > 5s 1.5 * Inom > 20s 1.25 * Inom temperature controlled		
Typical Idle Consumption	At idle < 10mA		
Bulk Charge	12V model	24V model	48V model
Floating Charge	14.6Vdc (default)	29.2Vdc (default)	29.2Vdc (default)
Equalization Charge	13.4Vdc (default)	26.8Vdc (default)	53.6Vdc (default)
Over Charge Disconnect	14.0Vdc (default)	28.0Vdc (default)	56.0Vdc (default)
Over Charge Recovery	14.8Vdc	29.6Vdc	59.2Vdc
Over Discharge Disconnect	13.6Vdc	27.2Vdc	54.427.2Vdc
Over Discharge Reconnect	10.8Vdc (default)	21.6Vdc (default)	43.2Vdc (default)
Temperature Compensation	12.3Vdc	24.6Vdc	49.2Vdc

Lead Acid Battery Settings	-13.2mV/°C	-26.4mV/°C	-52.8mV/°C
NiCad Battery Settings	Adjustable		
Typical Idle Consumption	Adjustable		
Load control mode	1. Low Voltage Reconnect (LVR): Adjustable 2. Low Voltage Disconnect (LVD): Automatic disconnection 3. Reconnection: Includes warning flash before disconnect & reconnection		
Low Voltage Reconnect	12.0-14.0Vdc	24.0-28.0Vdc	48.0-56.0Vdc
Low Voltage Disconnect	10.5-12.5Vdc	21.0-25.0Vdc	42.0-50.0Vdc
Ambient Temperature	0-40°C (Full load) 40-60°C (De-Rating)		
Altitude	Operating 5000 m, Non-Operating 16000 m		
Protection Class	IP21		
Battery Temperature Sensor ^①	BTS - Optional Remote battery temperature sensor for increased charging precision		
Terminal Size (Fine/Single Wire)	#8 AWG		

NOTE:

① The optional battery temperature sensor automatically adjusts the charging process of the controller according to the type of battery that is selected by user through battery type selector. With the battery temperature sensor installed, the controller will increase or decrease the battery charging voltage depending on the temperature of the battery to optimize the charge to the battery and maintain optional performance of the battery.

Maximum Power Point Tracking (MPPT) Function

Maximum Power Point Tracking, frequently referred to as MPPT, is an electronic system that operates the

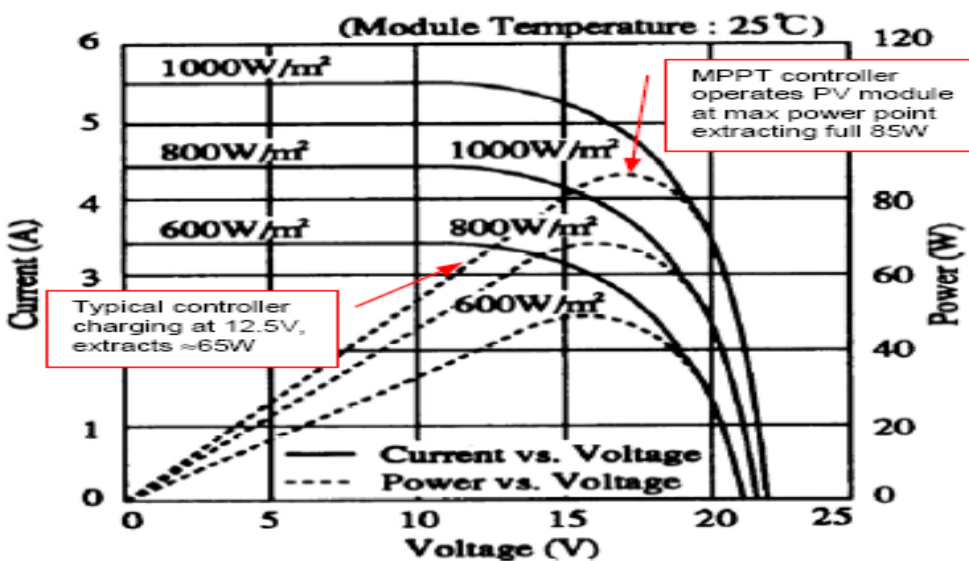

Photovoltaic (PV) modules in a manner that allows the modules to produce all the power they are capable of.

The PV-seeker Charge controller is a microprocessor-based system designed to implement the MPPT.

And it can increase charge current up to 30% or more compared to traditional charge controllers (see figure 1).

Figure 1 Current, Power vs. Voltage Characteristics

To guarantee the optimal performance of the solar charger, the input solar voltage range should be configured correctly. If the voltage falls out of this range, the charger will not work properly. Special attention should be paid to this in configuring the solar array.

2.5.5 Power Saver

There are two different working statuses for HIGH POWER inverter: “Power On” and “Power Off”.

When power switch is in “Unit Off” position, the inverter is powered off.

When power switch is turned to either of “Power Saver Auto” or “Power Saver Off”, the inverter is powered on.

Power saver function is to dedicated to conserve battery power when AC power is not or little required by the loads.

In this mode, the inverter pulses the AC output looking for an AC load (i.e., electrical appliance). Whenever an AC load (greater than 25 watts) is turned on, the inverter recognizes the need for power and automatically starts inverting and output goes to full voltage. When there is no load (or less than 25 watts) detected, the inverter automatically goes back into search mode to minimize energy consumption from the battery bank.

In “Power saver on” mode, the inverter will draw power mainly in sensing moments, thus the idle consumption is significantly reduced.

The inverter is factory defaulted to detect load for 250ms in every 3 seconds. This power sensing can be customized to “Unit off charging” via the SW3 on DIP switch.

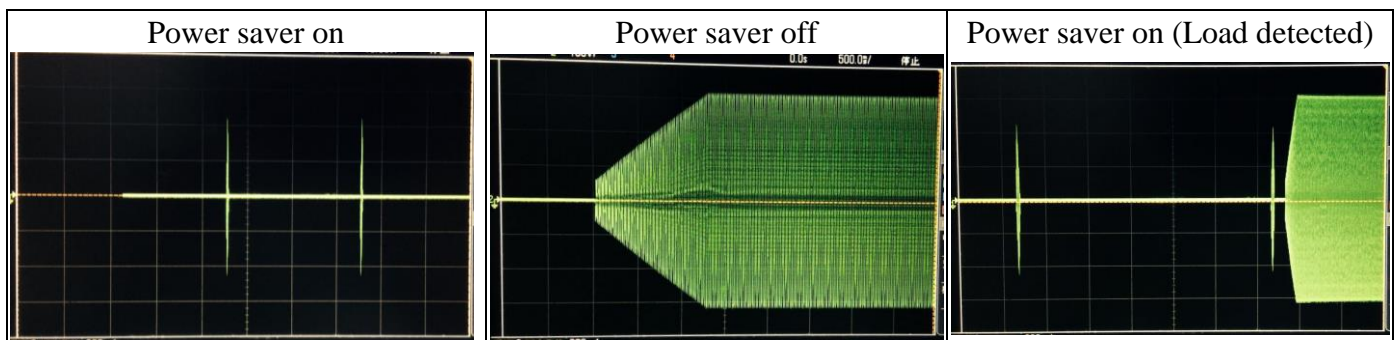

Note: The minimum power of a load to take inverter out of sleep mode (Power Saver On) is 50 Watts. For split phase models, the power threshold of sleep mode is 50W between Hot1 and Neutral and 200W between Hot 1 and Hot 2. There is no load detection between Hot2 and Neutral.

The whole High Power inverter is designed with extraordinarily low idle power consumption which is approximately 1.5% of its rated power.

High Power Inverter/Charger Idle Power Consumption(in Watts)

Model	Power Saver Off	Power Saver Auto	
	Idle(Max)	3Secs(Max)	Unit Off Charging
1KW	18W	7.5W	3W
1.5KW	25W	9W	
2KW	30W	10.0W	
3KW	60W	15.0W	
4KW	70W	20.0W	
5KW	80W	25.0W	
6KW	90W	25.0W	
8KW	120W	30.0W	

10KW	150W	35.0W	
12KW	180W	40.0W	
15KW	210W	50.0W	

For more detailed technical information, please contact us.

When in the search sense mode, the green power LED will blink and the inverter will make a ticking sound. At full output voltage, the green power LED will light steadily and the inverter will make a steady humming sound. When the inverter is used as an “uninterruptible” power supply the search sense mode function should be defeated.

Exceptions

Some devices when scanned by the load sensor cannot be detected. Small fluorescent lights are the most common example. (Try altering the plug polarity by turning the plug over.) Some computers and sophisticated electronics have power supplies that do not present a load until line voltage is available. When this occurs, each unit waits for the other to begin. To drive these loads either a small companion load must be used to bring the inverter out of its search mode, or the inverter may be programmed to remain at full output voltage.

Note: For split phase models, the power saver functionality is only available on Hot 1.

2.5.6 Protections

The High Power inverter/charger is equipped with extensive protections against various harsh situations/faults.

These protections include:

AC Input over voltage protection/AC Input low voltage protection

Low battery alarm/High battery alarm

Over temperature protection/Over load protection

Short Circuit protection (1s after fault)

Back feeding protection

When Over temperature /Over load occur, after the fault is cleared, the master switch has to be reset to restart the inverter.

The Low battery voltage trip point can be customized from defaulted value of 10VDC to 10.5VDC through the SW1 on the DIP switch.

The inverter will go to Over temp protection when the heat sink temp. $\geq 105^{\circ}\text{C}$ (221°F), and will go to Fault (shutdown Output) after 30 seconds. After temp drops to 90°C (194°F), the switch has to be reset to activate the inverter.

The High Power Inverter is with back feeding protection which avoids presenting an AC voltage on the AC input terminal in Invert mode.

After the reason for fault is cleared, the inverter has to be reset to start working.

2.5.7 Remote control

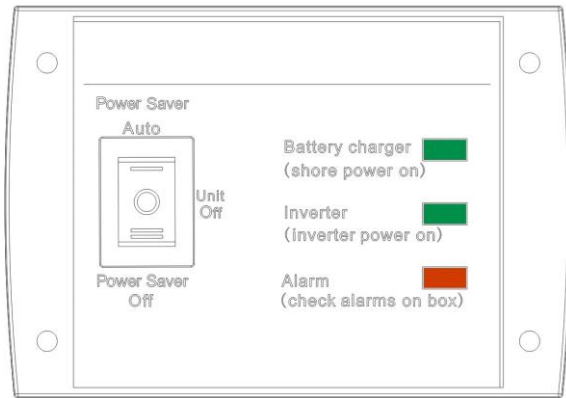

Apart from the switch panel on the front of the inverter, an extra switch panel connected to the RJ11 port at the DC side of the inverter through a standard telephone cable can also control the operation of the inverter remotely.

If an extra switch panel is connected to the inverter via “remote control port”, together with the panel on the inverter case, the two panels will be connected and operated in parallel.

Whichever first switches from “Unit Off” to “Power saver off” or “Power saver on”, it will power the inverter on.

If the commands from the two panels conflict, the inverter

will accept command according to the following priority:

Power saver on> Power saver off> Power off

Only when both panels are turned to “Unit Off” position, will the inverter be powered off.

The suggested length between the switch panel and inverter is 10 meters.

Never cut the telephone cable when the cable is attached to inverter and battery is connected to the inverter. Even the inverter is turned off, this will damage the remote PCB inside if the cable is short circuited during cutting.

The following picture shows the connection of a remote control panel to the inverter.

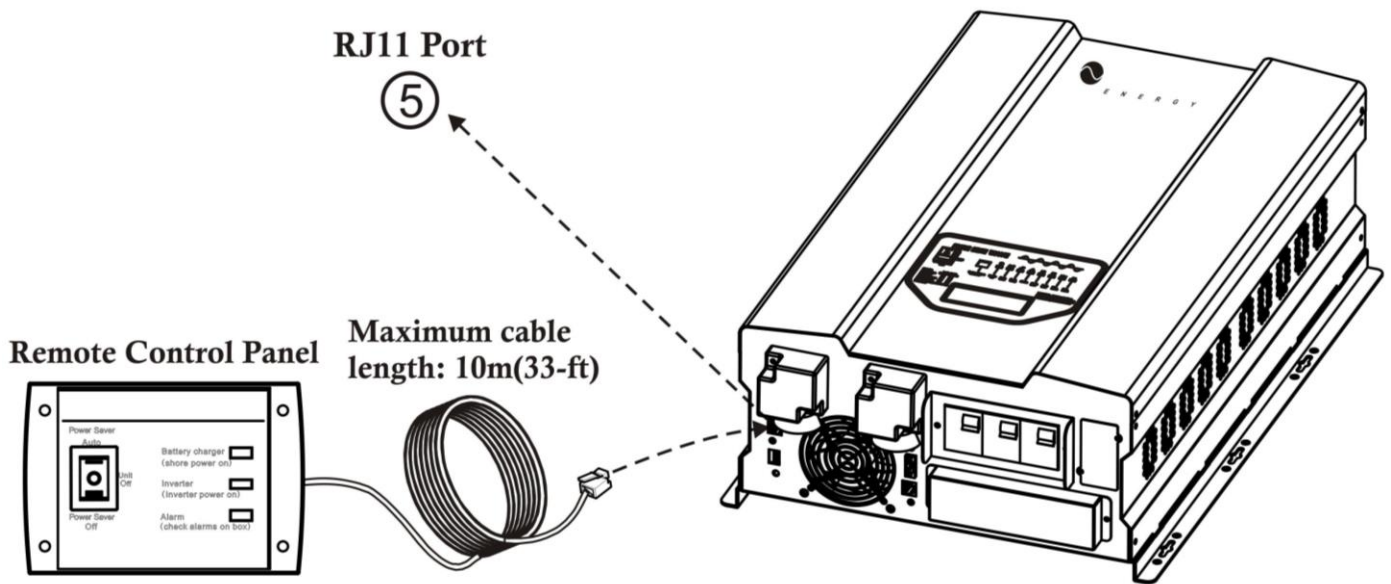

2.5.8 LED Indicator & LCD

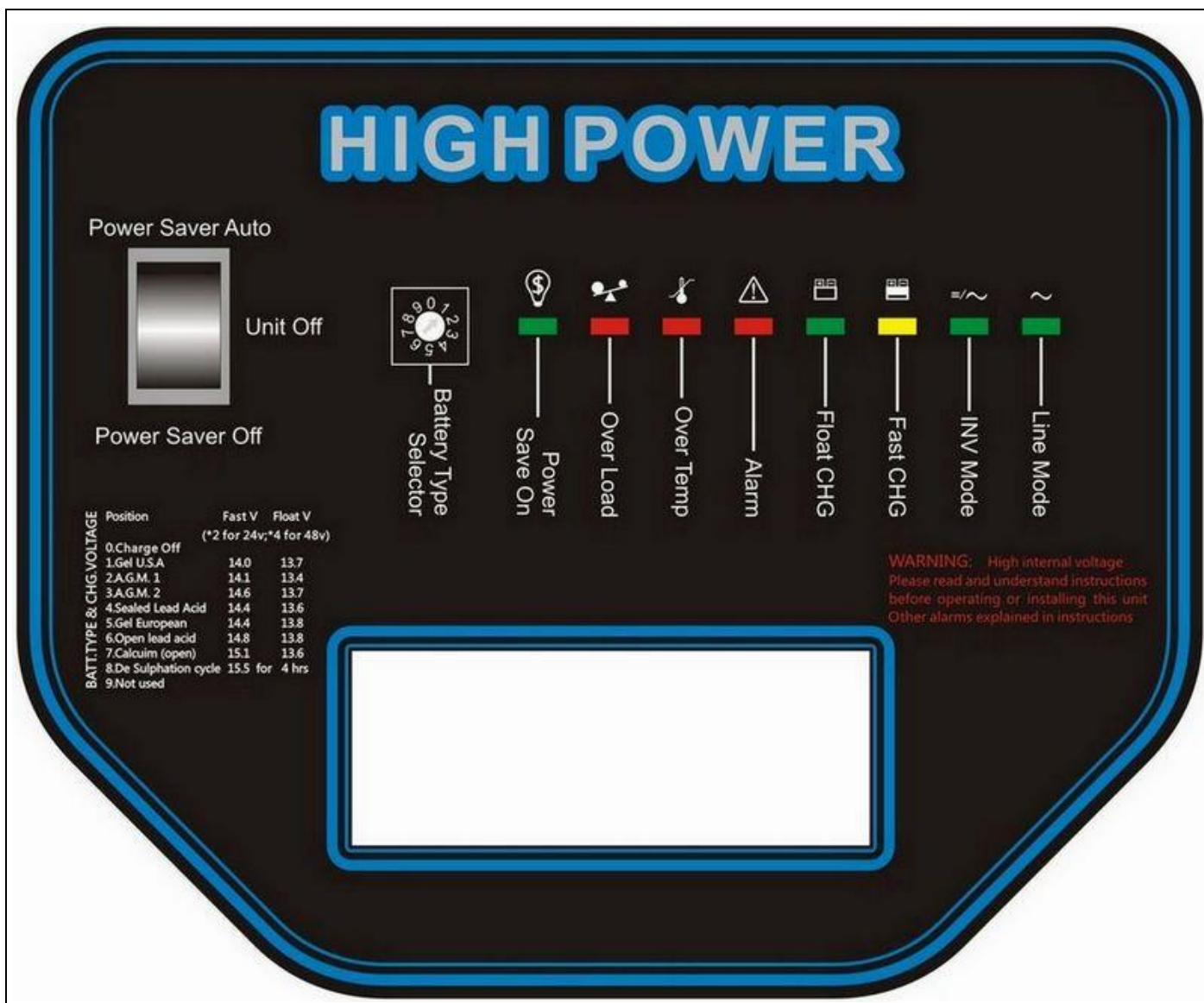

SHORE POWER ON	GREEN LED lighting on “Line Mode”
INVERTER ON	GREEN LED lighting on “Inv Mode”
FAST CHARGE	Yellow LED lighting on “Fast CHG”
FLOAT CHARGE	GREEN LED lighting on “Float CHG”
OVER TEMP TRIP	RED LED lighting on “Over Temp”
OVER LOAD TRIP	RED LED lighting on “Over Load”
POWER SAVER ON	GREEN LED lighting on “Power Saver on”

Please refer to ‘Indicator and Buzzer’ for the detailed information.

The LCD will display the following content:

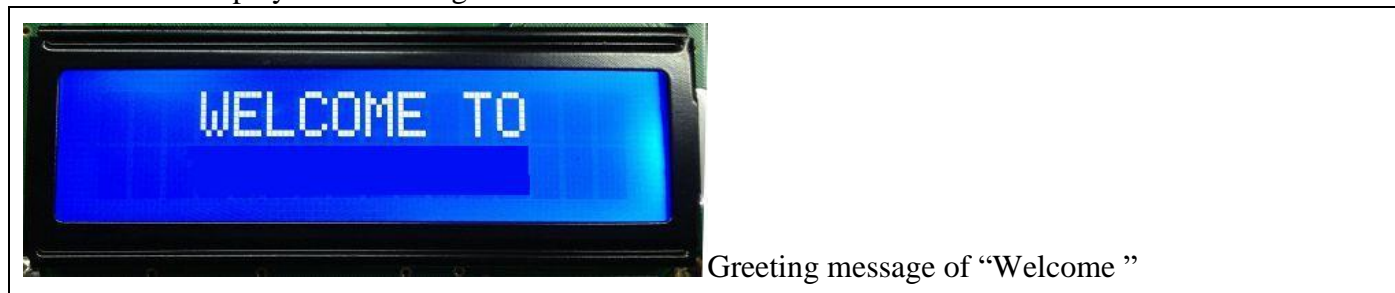



AC Status & Input Voltage

“AC: abnormal” is displayed when AC input is not qualified.



Output Voltage/Frequency and Output Current(in percentage) in Inverter mode



Battery voltage

Note:

When the inverter is in Battery Priority mode, “AC: abnormal” will also be displayed when the inverter finishes a complete charging circle and switches to inverter mode.

In AC mode, the LCD will not display the status of AC load.

2.5.9 Audible Alarm

The inverter also gives audible alarms when the following situations occur.

Battery Voltage Low	Inverter green LED Lighting, and the buzzer beep 0.5s every 5s.
Battery Voltage High	Inverter green LED Lighting, and the buzzer beep 0.5s every 1s, and Fault after 60s.
Invert Mode Over-Load	(1)110% < load < 125% ($\pm 10\%$), No audible alarm in 14 minutes, Beeps 0.5s every 1s in 15 th minute and Fault after 15 minutes; (2)125% < load < 150% ($\pm 10\%$), Beeps 0.5s every 1s and Fault after 60s; (3)Load > 150% ($\pm 10\%$), Beeps 0.5s every 1s and Fault after 20s;
Over Temperature	Heat sink temp. $\geq 105^{\circ}\text{C}$ (221°F), Over temp red LED Lighting, beeps 0.5s every 1s;

2.5.10 FAN Operation

For 1-3KW models, there is one multiple controlled DC fan.

For 4-6KW models, there are two DC fans.

For 8-15KW models, there are two multiple controlled DC fans and one AC fan. The DC fan will work in the same way as the one on 1-3KW, while the AC fan will work once there is AC output from the inverter. So when the inverter is in power saver mode, the AC fan will work from time to time in response to the pulse sent by the inverter in power saver mode.

The DC fans are designed to operate according to the following logic:

Condition	Enter Condition	Leave condition	Speed
HEAT SINK TEMPERATURE	$T \leq 60^{\circ}\text{C}(140^{\circ}\text{F})$	$T > 65^{\circ}\text{C}(149^{\circ}\text{F})$	OFF
	$65^{\circ}\text{C}(149^{\circ}\text{F}) \leq T < 85^{\circ}\text{C}(185^{\circ}\text{F})$	$T \leq 60^{\circ}\text{C}(140^{\circ}\text{F})$ or $T \geq 85^{\circ}\text{C}(185^{\circ}\text{F})$	50%
	$T > 85^{\circ}\text{C}(185^{\circ}\text{F})$	$T \leq 80^{\circ}\text{C}(176^{\circ}\text{F})$	100%
CHARGER CURRENT	$I \leq 15\%$	$I \geq 20\%$	OFF
	$20\% < I \leq 50\% \text{Max}$	$I \leq 15\%$ or $I > 50\% \text{Max}$	50%
	$I > 50\% \text{Max}$	$I \leq 40\% \text{Max}$	100%
LOAD Percentage (INV MODE)	Load $< 30\%$	Load $\geq 30\%$	OFF
	$30\% \leq \text{Load} < 50\%$	Load $\leq 20\%$ or Load $\geq 50\%$	50%
	Load $\geq 50\%$	Load $\leq 40\%$	100%

Allow at least 30CM of clearance around the inverter for air flow. Make sure that the air can circulate freely around the unit.

Fan noise level <60db at a distance of 1m

2.5.11 DIP Switches

On the DC end of inverter, there are five DIP switches which enable users to customize the performance of the device.

Switch #	Switch Function	Position: 0	Position: 1
SW1(AC Priority)	Low Battery Trip Point	10.0VDC	10.5VDC
SW1(Battery Priority)		10.5VDC	11.5VDC
SW2(230Vac)	AC Input Range	176-242Vac $\pm 4\%$	160-264Vac(40Hz+) $\pm 4\%$
SW2(120Vac)	AC Input Range	100-135Vac $\pm 4\%$	90-135Vac(40Hz+) $\pm 4\%$
SW3	Power Save Override ON/OFF	Inverter Off	Power Saver On(3 sec)
SW4	Frequency Switch	50Hz	60Hz
SW5	Battery/AC Priority	AC Priority	Battery Priority

Low Battery Trip Point (SW1):

Deep discharge of the lead acid battery leads to high losses in capacity and early aging. In different applications a different low voltage disconnection level is preferred. For example, for solar applications, user may intend to have less DOD to prolong the battery life cycle. While for mobile applications users may intend to have more DOD to reduce battery capacity and on board weight.

For 12VDC models, when the inverter is in AC priority mode (SW5 at "0"), Low Battery Trip Point is selectable at 10.0/10.5VDC. It can be customized to 10.5/11.5Vdc via SW5. This is to prevent batteries from over-discharging while there is only a small load applied on the inverter.

*2 for 24VDC, *4 for 48VDC

AC Input Range (SW2):

There are different acceptable AC input ranges for different kinds of loads.

For some relatively sensitive electronic devices, a narrow input range of 176-242VAC (100-135V for 120Vac models) is required to protect them.

While for some resistive loads which work in a wide voltage range, the input AC range can be customized to 160-264VAC (90-135V for 120Vac models), this helps to power loads with the most AC input power without frequent switches to the battery bank.

In order to make the inverter accept dirty power from a generator, when the SW2 is switched to position "1", the inverter will bypass an AC input with a wider voltage and frequency (40Hz plus for 50Hz/60Hz).

Accordingly, the AC charger will also work in a wider voltage and freq range (43Hz plus for 50Hz/60Hz).

This will avoid frequent switches between battery and generator. But some sensitive loads will suffer from the low quality power.

The pros and cons should be clearly realized.

Power Save Override ON/OFF (SW3):

Under the Battery Priority Mode (SW5 in position "1"), the inverter can be switched between two modes: Power Saver Mode (SW3 in position "1") and Unit Off Charging Mode (SW3 in position "0"). The power Switch should be in "Power saver on" position all the time for using these functions.

In Power Saver Mode, the inverter is initially in standby mode and sends a pulse to detect the presence of a load every 3 seconds. Each pulse lasts for 250ms. The inverter will remain in standby mode until a load has been detected. Then it will wake up from standby mode and start to invert electricity from the battery bank to supply the load. As this function is under Battery Priority, the inverter will always prefer to invert electricity from battery first even there is a qualified AC input present. Only when the battery voltage is lower than the low voltage alarm point, will the inverter switch to AC input power to charge the battery and supply the load at the same time.

This Power Saver Mode can be changed to Unit Off Charging mode via SW3 by switching it to "0" position (SW5 still in "1").

"Unit Off Charging" will enable the inverter charger to charge batteries as much as possible while without discharging them.

In "Unit Off Charging" mode, the inverter will stay in standby mode without sensing loads. It won't output any power even if a load is turned on, and only stay idle in this mode when there is no AC input.

When a qualified AC input is present, it will start charging the battery and transfer power to loads.

This feature is ideally suitable for applications where energy conservation for batteries is required.

Charging will be activated once qualified AC exists, while discharging is disabled.

The inverter only consumes as little as 3 watts in "Unit Off Charging" mode.

Output Frequency(SW4):

The output frequency of the inverter can be set at either 50Hz or 60Hz by SW4 which make the inverter charger an international models for most electricity systems.

AC/Battery Priority (SW5):

The Sigineer Power inverter chargers are designed with AC/Battery priority switch (DIP switch #5).

Switch the battery priority selector to Position "0" for AC priority mode, Position "1" for battery priority

mode. In AC priority mode, when AC input is present, the battery will be charged first, and the inverter will transfer the input AC to power the load. Only when the AC input is stable for a continuous period of 15 days

will the inverter start a battery inverting cycle to protect the battery. After 1 normal charging cycle ac through put will be restored.

When you choose battery priority, the inverter will invert from battery despite the AC input.

When the battery voltage reaches the low voltage alarm point which is (0.5Vdc for 12V, 1Vdc for 24V, 2V for 48Vdc) higher than “**Low Battery Trip Point**”, the inverter will transfer to AC input, charge battery, and switch back to battery when the battery is fully charged. This function is mainly for wind/solar systems using utility power or generator as back up.

Switch #	Switch Function	Position: 0	Position: 1
SW1(AC Priority)	Low Battery Alarm Point	10.5VDC	11VDC
SW1(Battery Priority)		11VDC	12VDC

*2 for 24VDC, *4 for 48VDC

The AC/Battery Priority function can be activated by sliding the switch even when the inverter is in operation.

Note: In battery priority mode, when qualified AC inputs for the first time and the battery voltage is below 12.5Vdc (12.5Vdc for 12Vdc, 25Vdc for 24Vdc, 51Vdc for 48Vdc), the inverter will first carry out a cycle of bulk charging and absorb charging, the inverter will not go into float charging mode. Choosing the battery type selector to “0” will disable the built-in battery charger while still allow transfer through. When battery charger is disabled, if the battery is charged by external DC power to 13.5Vdc (13.5Vdc for 12Vdc, 27Vdc for 24Vdc, 54Vdc for 48Vdc), the inverter will go to battery priority mode again.

2.5.12 Auto Generator Start

The inverter can start up generator when battery voltage goes low.

When the inverter goes to low battery alarm, it can send a signal to start a generator and turn the generator off after battery charging is finished.

The auto gen start feature will only work with generators which have automatic starting capability. The generator must have start and stop controls [i.e., an electric starter and electric choke (for gasoline units)], and the safety sensors to be able to start and stop automatically.

There is an open/close relay (constant open) that will close and short circuit the positive and negative cables from a generator start control. The input DC voltage can vary, but the max current the relay can carry is 16Amp.

The Auto Generator Start terminal pins are not polarized.

In addition, these two pins can also be used as dry contacts to send out “Low Battery Voltage” signal to an external alarm device.

This AGS relay can also carry AC voltage within its capacity.

This inverter will skip the float charging when it is set at battery priority mode, so that the generator will no longer be kept running to maintain a small charge on the batteries.

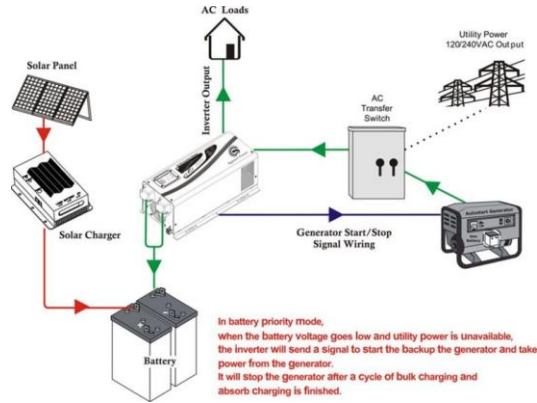

2.5.13 Battery Temperature Sensing

Applying the proper charge voltage is critical for achieving optimum battery performance and longevity. The ideal charge voltage required by batteries changes with battery temperature.

The battery temperature sensor allows the charge controller to continuously adjust charge voltage based on actual battery temperature.

Temperature compensation of charge voltage assures that the battery receives the proper charge voltage as battery temperature varies.

The entire line are equipped with Battery Temperature Sensing for increased charging precision.

It sends precise information to the charger, which automatically adjusts voltage to help ensure full battery charge depending on the ambient temperature of your battery installation.

When the battery voltage is over 40°C (104°F), it will reduce the charging voltage by 0.1Vdc with every degree of temperature rise.

We recommend that you install Battery Temperature Sensors on all banks to protect your batteries and to provide optimal charging of each bank.

The battery temperature sensor mounts on the side of a battery or any other location where the precise temperature of battery can be detected such as battery mounting racks.

The following table describes approximately how much the voltage may vary depending on the temperature of the batteries.

Inverter Condition	Temperature on BTS	Charger Operation
Charger Mode	BTS ≥ 50°C (122°F)	Automatically turns off charger
	BTS ≤ 40°C (104°F)	Automatically turns on charger
Inverter Mode	40°C (104°F) ≤ BTS ≤ 50°C (122°F)	Increases the low voltage shut down point by 0.5Vdc
	BTS ≥ 50°C (122°F)	Over Temp Fault

A Battery Temperature Sensor has been provided as a separate accessory. It comes with 32.8'/10m cable.

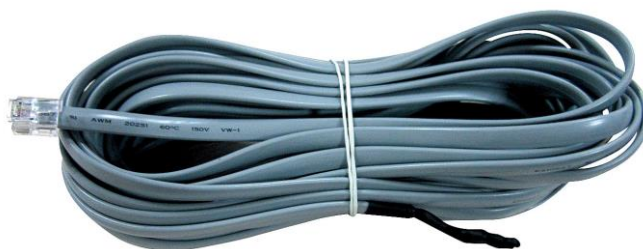

Important: If the battery temperature is allowed to fall to extremely cold temperatures, the inverter with a BTS may not be able to properly recharge cold batteries due to maximum voltage limits of the inverter. Ensure the batteries are protected from extreme temperatures. For more detailed technical information, please contact us .

2.5.14 Other Features

Low Battery Voltage Recovery Start

After low battery voltage shut off(10V for 12V model or 20V for 24V model or 40V for 48V model), the inverter is able to restore to work after the battery voltage recovers to 13V/26V/52V(with power switch still in “On” position). This function helps to save the users extra labor to reactivate the inverter when the low battery voltage returns to acceptable range in renewable energy systems.



WARNING

Never leave the loads unattended, some loads (like a Heater) may cause accidents in such cases. It is better to shut everything off after low voltage trip than to leave your load in the risk of fire. Nobody wants to return home, finding house surrounded by fire trucks and naughty neighborhood kids toasting hot dogs against his house.

Conformal Coating

The entire line of inverters have been processed with a conformal coating on the PCB, making it water, rust, and dust resistant.

While these units are designed to withstand corrosion from the salty air, they are not splash proof.

Remote Control for Output Frequency of 60Hz/62.5Hz

The 15KW inverter chargers are designed with a 2 pin dry contact on the upper side of the negative DC post.



It works in junction with SW4 DIP switch and overrides the original SW4 function in the manual. Pls refer to this sheet for the actual operation of SW4.

Frequency Setting				
SW4 Position	0	1	0	1
Dry Contact Status	Open	Open	Close	Close
Frequency	60Hz	62.5Hz		

3 Installation

3.1 Location

Follow all the local regulations to install the inverter.

Please install the equipment in a location of Dry, Clean, Cool with good ventilation.

Working temperature: - 10°C to 40°C (-14°F to 104°F)

Storage temperature: - 40°C to 70°C (-40°F to 158°F)

Relative Humidity: 0% to 95%, non-condensing

Cooling: Forced air

Warning! Operation in a condensing environment will invalid warranty.

3.2 DC Wiring Recommendation

It is suggested the battery bank be kept as close as possible to the inverter. The following table is a suggested wiring option for DC cable with length from 1 meter to 5 meters.

Model Watt	Battery Voltage	Minimum Wire Gage		Model Watt	Battery Voltage	Minimum Wire Gage	
		0~1.0m	1.0~5.0m			0~1.0m	1.0~5.0m
1KW	12 Vdc	30mm ²	40mm ²	2KW	12 Vdc	60mm ²	75mm ²
1KW	24 Vdc	15mm ²	20mm ²	2KW	24 Vdc	30mm ²	45mm ²
1KW	48 Vdc	10mm ²	15mm ²	2KW	48 Vdc	15mm ²	25mm ²
3KW	12 Vdc	90mm ²	120mm ²	4KW	12 Vdc	120mm ²	150mm ²
3KW	24 Vdc	45mm ²	60mm ²	4KW	24 Vdc	60mm ²	75mm ²
3KW	48 Vdc	25mm ²	30mm ²	4KW	48 Vdc	30mm ²	40mm ²
5KW	24 Vdc	75mm ²	95mm ²	6KW	24 Vdc	90mm ²	120mm ²
5KW	48 Vdc	40mm ²	50mm ²	6KW	48 Vdc	45mm ²	60mm ²
8KW	24 Vdc	120mm ²	150mm ²	10KW	48 Vdc	75mm ²	95mm ²
8KW	48 Vdc	60mm ²	75mm ²	12KW	48 Vdc	90mm ²	120mm ²

Please follow the above minimum wire size requirement.

One cable is always best, but if there is a problem obtaining for example 100mm² cable, use 2*50mm² or 3*35mm² instead, as long as the square area adds up. Performance of any product can be improved by thicker cable and shorter runs, so if in doubt round up and keep the length as short as possible.

Battery cables must have crimped (or preferably, soldered and crimped) copper compression lugs unless aluminum mechanical lugs are used. Soldered connections alone are not acceptable. High quality, UL-listed battery cables are available. These cables are color-coded with pressure crimped, sealed ring terminals.

Battery terminal must be clean to reduce the resistance between the DC terminal and cable connection. A buildup of dirt or oxidation may eventually lead to the cable terminal overheating during periods of high current draw. Use a stiff wire brush and remove all dirt and corrosion from the battery terminals and cables.

Do not place anything
between battery cable lug
and terminal surface.
Assemble exactly as shown.

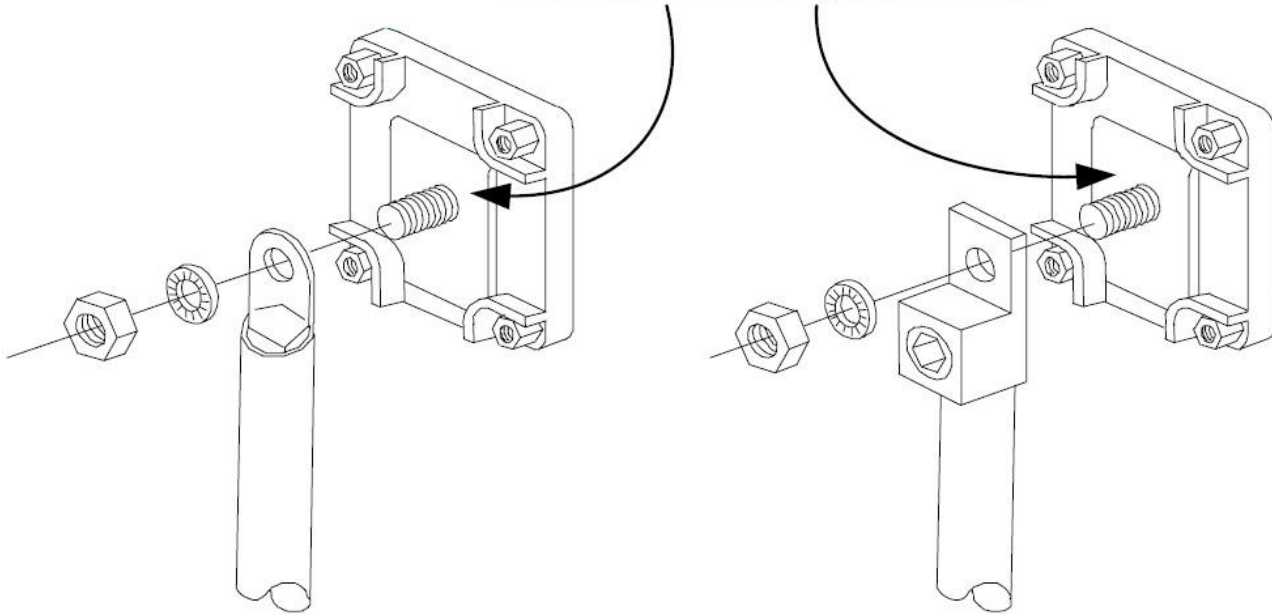

2/0 Copper Compression Lug

2/0 Aluminum Mechanical Lug

Reducing RF interference

To reduce the effect of radiated interference, twist the DC cables. To further reduce RF interference, shield the cables with sheathing /copper foil / braiding.

Taping battery cables together to reduce inductance

Do not keep the battery cables far apart. In case it is not convenient to twist the cables, keep them taped together to reduce their inductance. Reduced inductance of the battery cables helps to reduce induced voltages. This reduces ripple in the battery cables and improves performance and efficiency.

 WARNING	The torque rating range for DC terminal is 12.5NM-20.5NM(9.25-15.19 pound-foot), and the suggested torque rating is 17NM(12.6 pound-foot). Over torquing may cause the bolt to break.
	<p>Equipment Damage</p> The inverter is not reverse polarity protected. Reversing the battery polarity on the DC input connections will cause permanent damage to the inverter which is not covered under warranty. Always check polarity before making connections to the inverter.
	The inverter contains capacitors that may produce a spark when first connected to battery. Do not mount in a confined a battery or gas compartment.
	Ensure the inverter is off before disconnecting the battery cables, and that AC power is disconnected from the inverter input.

3.3 AC Wiring Recommendation

We recommend using 10 to 5Awg wire to connect to the ac terminal block.

When in AC mode the AC input power will supply both the loads and AC charger, a thicker wire gauge for AC Input is required. Please consult a qualified electrician about the specific wire gauge required in terms of wire material and inverter power.

There are 3 different ways of connecting to the terminal block depending on the model. Call our tech support if you are not sure about how to wire any part of your inverter.

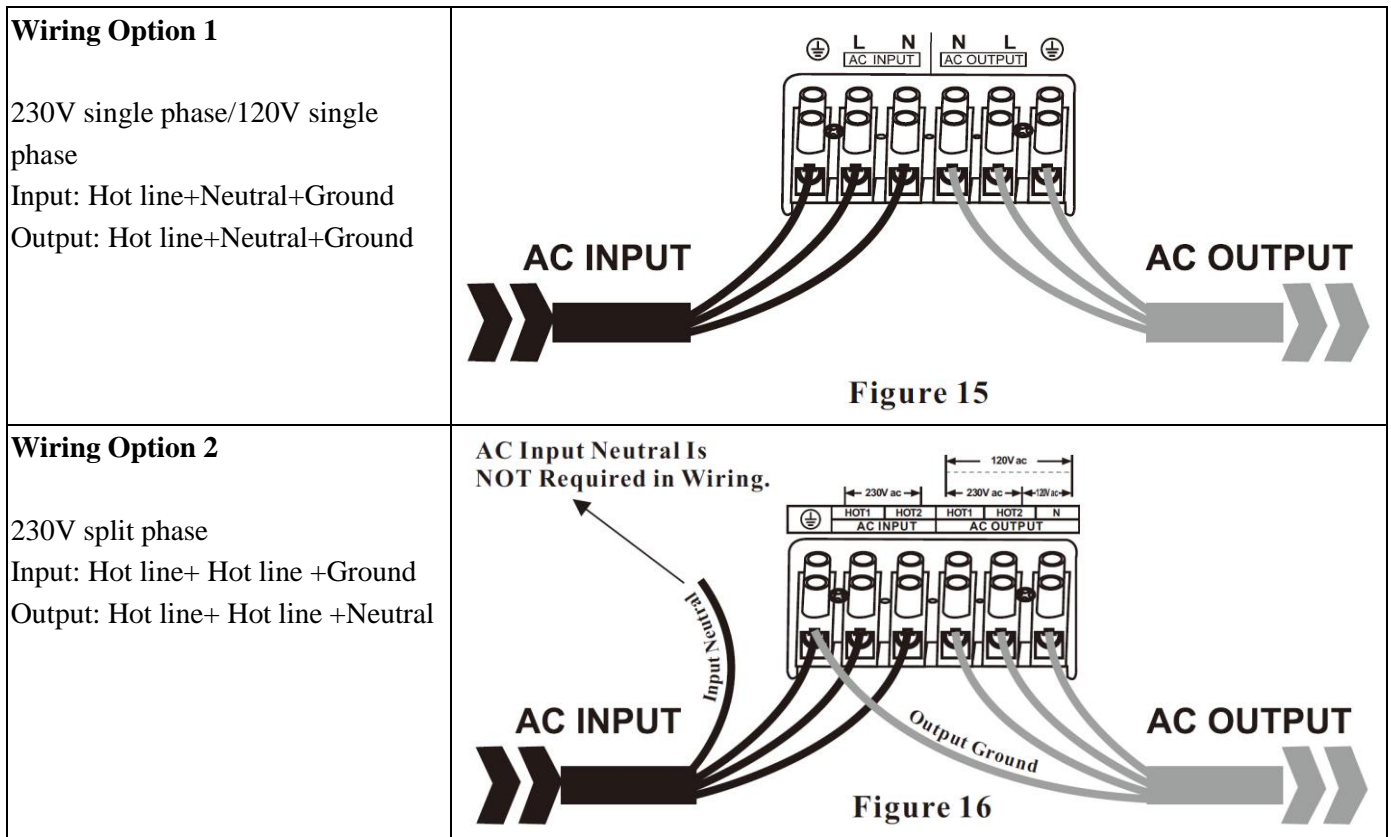

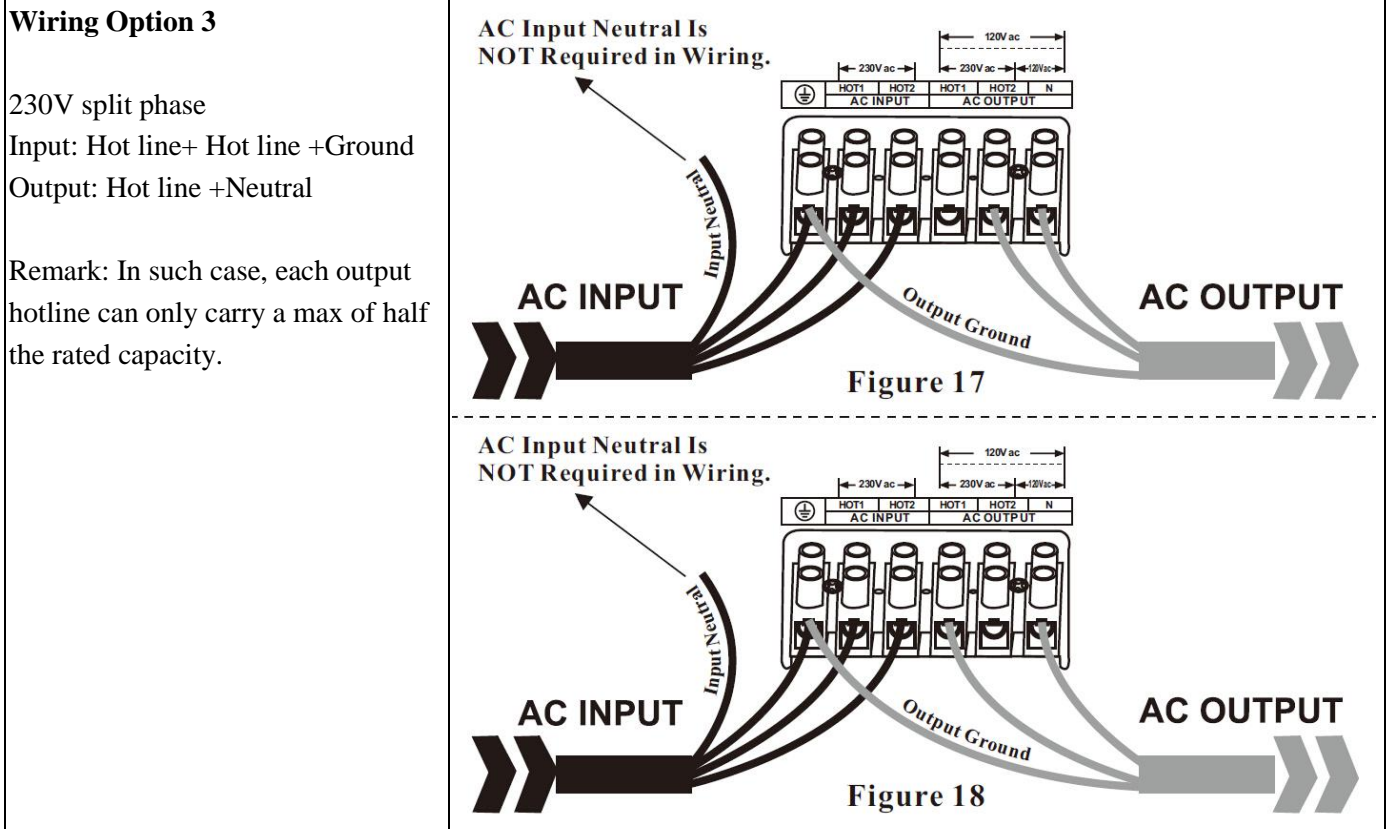

Caution:

Wiring Option 2 and Wiring Option 3 are only allowed for split phase models. Please wire all the other models according to Wiring Option 1.



WARNING

For split phase models, AC input neutral is not required in wiring. Never Connect Input Neutral to Ground or to Output Neutral. Damage will result which is not covered under warranty.

The output voltage of this unit must never be connected in its input AC terminal, overload or damage may result.

Always switch on the inverter before plugging in any appliance.

Damages caused by AC wiring mistakes are not covered under warranty.

Preventing Paralleling of the AC Output

The AC output of the unit should never be connected to the utility power / generator. Such a connection may result in parallel operation of the different power sources and AC power from the utility / generator will be fed back into the unit which will instantly damage the inverter and may also pose a fire and safety hazard.

3.4 Grounding

Connect an AWG 8 gauge or greater copper wire between the grounding terminal on the inverter and the earth grounding system or the vehicle chassis.

3.5 Mounting Flange

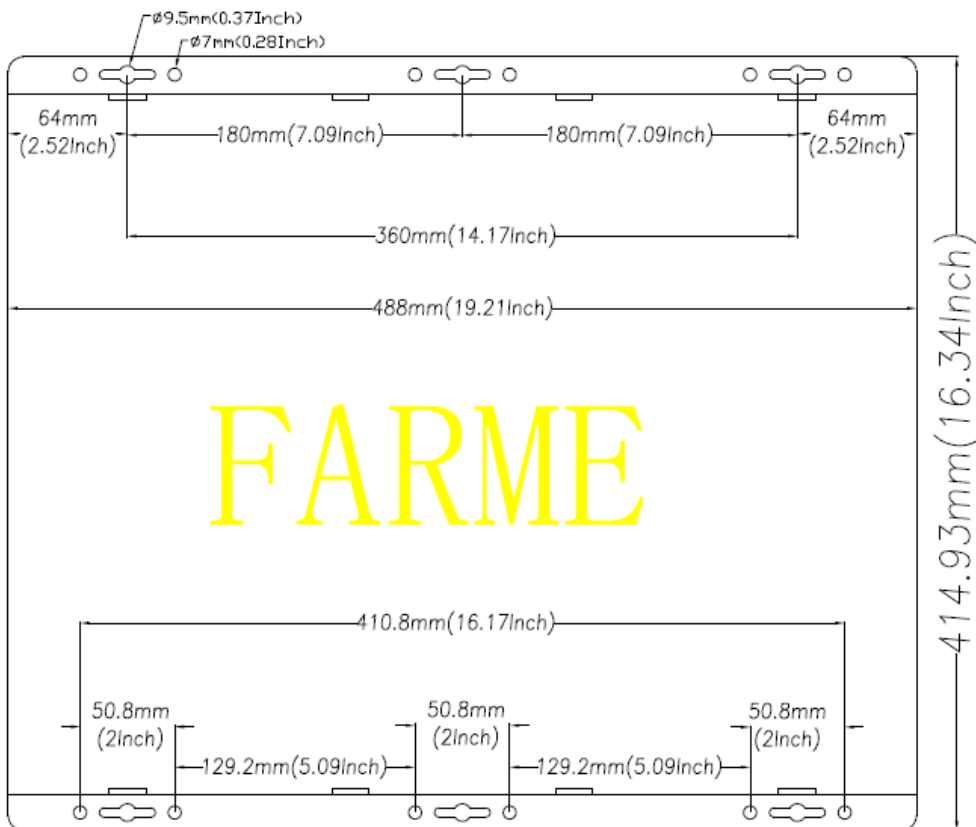
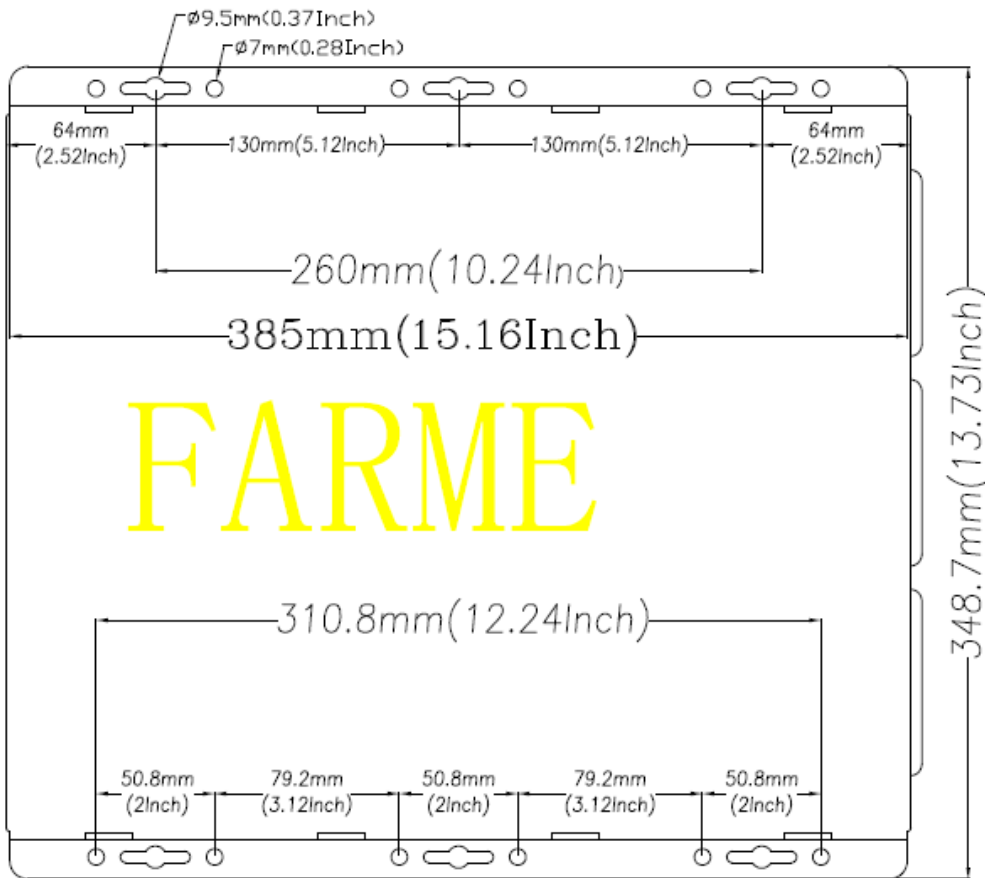

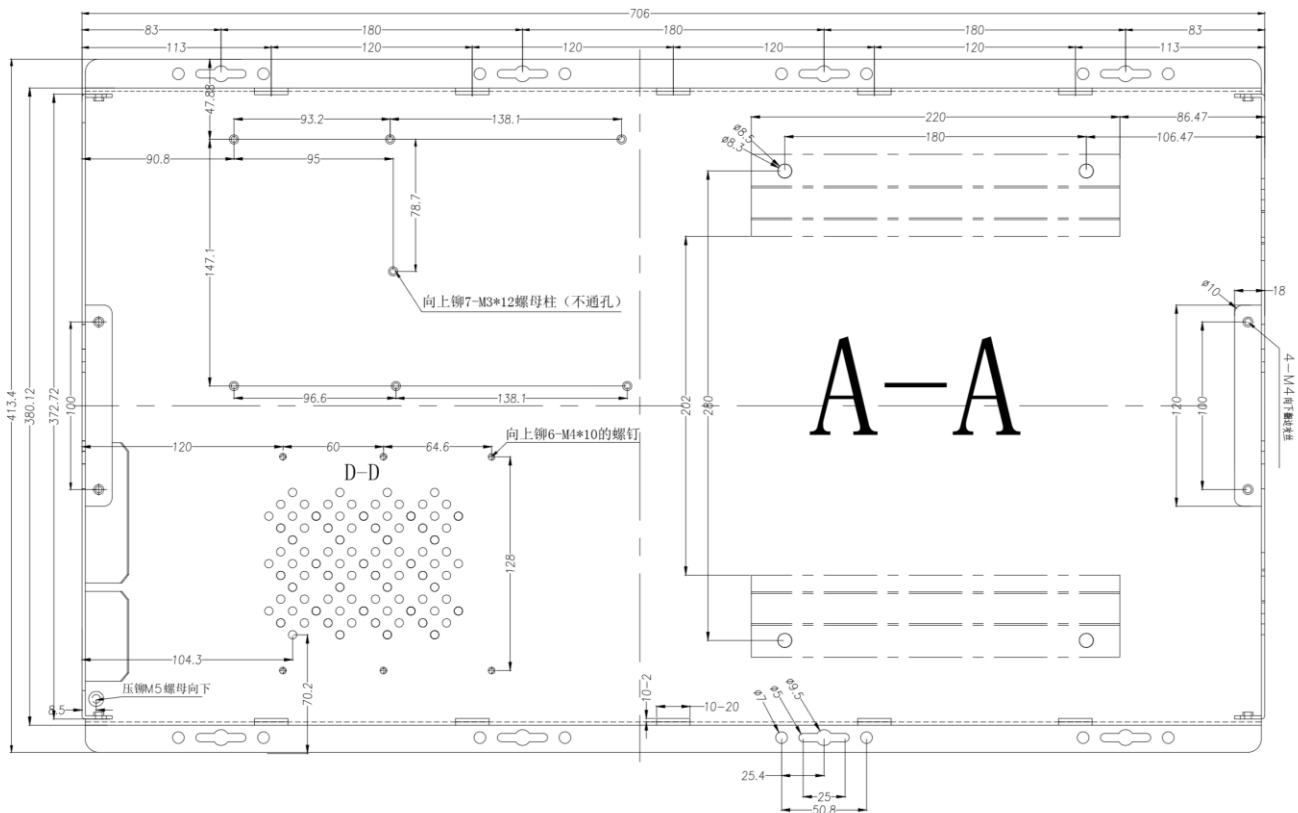
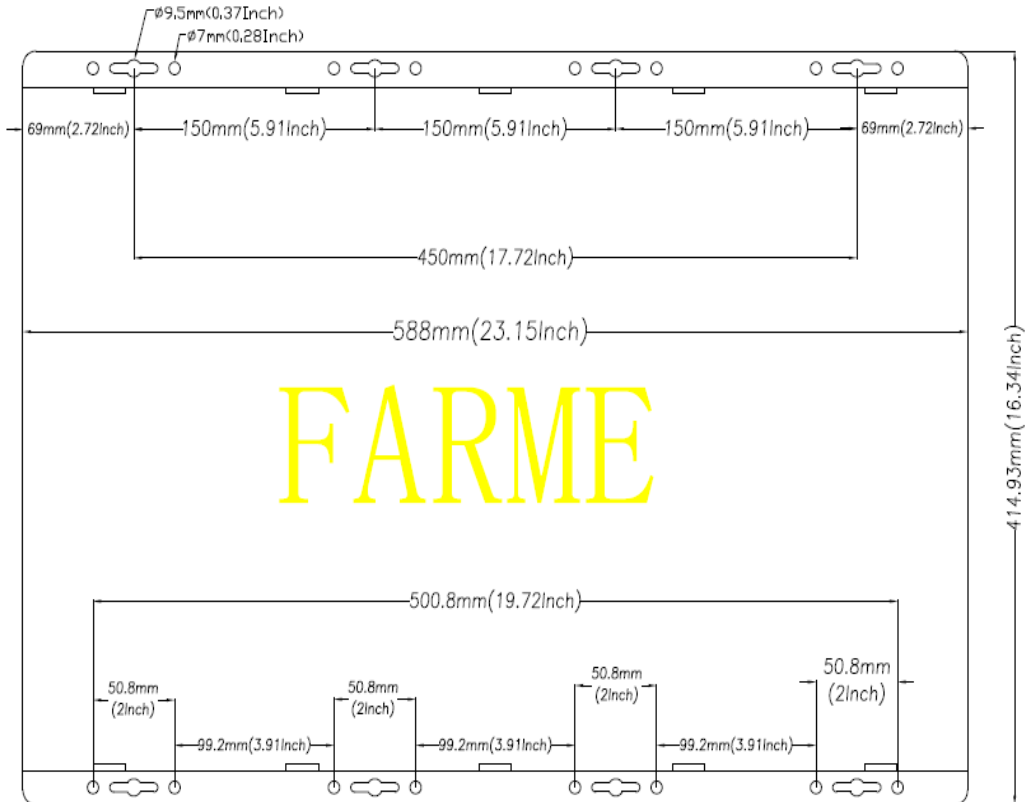

4 Maintenance & Troubleshooting

This troubleshooting guide contains information about how to troubleshoot possible error conditions while using the HIGH POWER Pure Sine Wave Inverter/Charger.

The following chart is designed to help you quickly pinpoint the most common inverter failures.

Indicator and Buzzer

Status	Item	Indicator on top cover						LED on Remote Switch			Buzzer	
		SHORE POWER ON	INVERTER ON	FAST CHG	FLOAT CHG	OVER TEMP TRIP	OVER LOAD TRIP	POWER SAVER ON	BATT CHG	INVERTER		Alarm
Line Mode	CC	√		√					√			
	CV	√		√, blink					√			
	Float	√			√				√			
	Standby	√										
Inverter Mode	Inverter On		√							√		
	Power Saver							√				
Inverter Mode	Battery Low		√							√	√	Beep 0.5s every 5s
	Battery High		√							√	√	Beep 0.5s every 1s
	Overload On Invert Mode		√				√			√	√	Refer to “Audible alarm”
	Over-Temp On Invert Mode		√			√				√	√	Beep 0.5s every 1s
	Over-Temp On Line Mode	√		√		√			√		√	Beep 0.5s every 1s
	Over Charge	√		√					√		√	Beep 0.5s every 1s
Fault Mode	Fan Lock											Beep continuous
	Battery High		√							√		Beep continuous
	Inverter Mode Overload						√					Beep continuous
	Output Short						√				√	Beep continuous
	Over-Temp					√						Beep continuous
	Over Charge			√					√			Beep continuous
	Back Feed Short											Beep continuous

Symptom	Possible Cause(s)	Recommended Solution(s)
Inverter will not turn on during initial power up.	Batteries are not connected, loose battery-side connections. Low battery voltage.	Check the batteries and cable connections. Check DC fuse and breaker. Charge the battery.
No AC output voltage and no indicator lights ON.	Inverter has been manually transitioned to OFF mode.	Press the switch to Power saver on or Power saver off position.
Inverter overload indicator on	Excessive AC output load or AC output short Defective inverter	Check AC output loads and wiring
Inverter high temperature indicator on	Excessive ambient temperature or AC output load	Check AC output loads, increase ventilation, derate the inverter if ambient temperature is excessive.
AC output voltage is low and the inverter turns loads OFF in a short time.	Low battery.	Check the condition of the batteries and recharge if possible.
Charger is inoperative and unit will not accept AC.	AC voltage has dropped out-of-tolerance	Check the AC voltage for proper voltage and frequency.
Charger is supplying a lower charge rate.	Charger controls are improperly set. Low AC input voltage. Loose battery or AC input connections.	Refer to the section on adjusting the "Charger Rate". Source qualified AC power.. Check all DC /AC connections.
Charger turns OFF while charging from a generator.	High AC input voltages from the generator.	Load the generator down with a heavy load. Turn the generator output voltage down.
Sensitive loads turn off temporarily when transferring between grid and inverting.	Inverter's Low voltage trip voltage may be too low to sustain certain loads.	Choose narrow AC voltage in the DIP switch, or Install a UPS if possible.
Noise from Transformer/case*	Applying specific loads such as hair drier	Remove the loads

***The reason for the noise from transformer and/or case**

When in inverter mode and the transformer and/or case of the inverter sometimes may vibrate and make noise.

The noise may come from transformer.

According to the characteristics of our inverter, there is one type of load which will most likely to cause rattles of transformer, that is a half-wave load, load that uses only a half cycle of the power(see figure 1). This trends to cause imbalance of magnetic field of transformer, reducing its rated working freq from 20KHz to, say, maybe 15KHz (it varies according to different loads). This way, the freq of noise falls exactly into the range (200Hz-20KHz) that human ear can sense.

The most common load of such kind is hair drier.

If the noise comes from case.

Normally when loaded with inductive loads, the magnetic field generated by transformer keeps attracting or releasing the steel case at a specific freq, this may also cause noise.

This noise may also be generated the moment a load is detected in the power saver mode.

Reducing the load power or using an inverter with bigger capacity will normally solve this problem.

The noise willn't do any harm to the inverter or the loads.

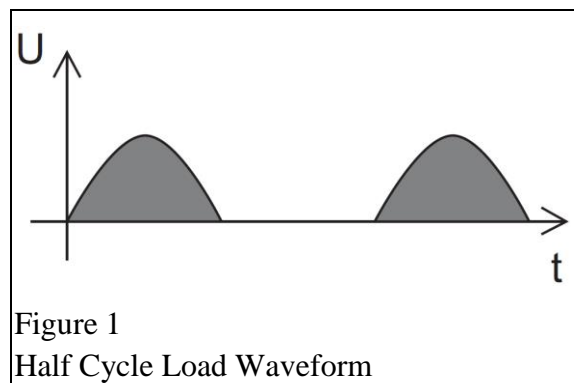

5 Warranty

We warrant this product against defects in materials and workmanship for a period of one year from the date of purchase and will repair or replace any defective High Power Inverter when directly returned, postage prepaid, to manufacturer. This warranty will be considered void if the unit has suffered any obvious physical damage or alteration either internally or externally and does not cover damage arising from improper use such as plugging the unit into an unsuitable power sources, attempting to operate products with excessive power consumption requirements, reverse polarity, or use in unsuitable climates.

WARRANTY DOES NOT INCLUDE LABOR, TRAVEL CHARGES, OR ANY OTHER COSTS INCURRED FOR REPAIR, REMOVAL, INSTALLATION, SERVICING, DIAGNOSING OR HANDLING OF EITHER DEFECTIVE PARTS OR REPLACEMENT PARTS. THE WARRANTOR ASSUMES NO LIABILITY FOR INCIDENTAL OR CONSEQUENTIAL DAMAGES OF ANY KIND.

LOSS OR DAMAGE: Loss or damage in transit is the responsibility of the carrier. Any claim should be filed with the delivering transport company. Invoice, Bill of Lading and Delivery receipt with damage noted therein must accompany any claims for freight damage. Claims for shortage and lost shipments must be made in writing to the shipper within 3 days of the receipt of shipment. Claims not reported within this time frame will not be honored.

This warranty does not apply to and we will not be responsible for any defect in or damage to:

- a) the product if it has been misused, neglected, improperly installed, physically damaged or altered, either internally or externally, or damaged from improper use or use in an unsuitable environment; violations of the warnings in the manual will invalidate the warranty.
- b) the product if it has been subjected to fire, water, generalized corrosion, biological infestations, or input voltage that creates operating conditions beyond the maximum or minimum limits listed in the product specifications including high input voltage from generators and lightning strikes;
- c) the product if repairs have been done to it other than by us or its authorized service centers;

Appendix 1 : High Power Inverter/Charger Spec Sheet

Pure Sine Wave Inverter & Charger Spec Sheet												
Electrical Specifications												
	Model	1KW	1.5KW	2KW	3KW	4KW	5KW	6KW	8KW	10KW	12KW	15KW
Inverter Output	Continuous Output Power	1000W	1500W	2000W	3000W	4000W	5000W	6000W	8000W	10000W	12000W	15000W
	Surge Rating(20s)	3000W	4500W	6000W	9000W	12000W	15000W	18000W	24000W	30000W	36000W	45000W
	Capable of Starting Electric Motor	1HP	1.5HP	2HP	3HP	4HP	5HP	6HP	8HP	10HP	12HP	15HP
	Output Waveform	Pure Sine wave/Same as input(Bypass mode)										
	Nominal Efficiency	>88%(Peak)										
	Line Mode Efficiency	>95%										
	Power Factor	0.9-1.0										
	Nominal Output Voltage RMS	100-110-120Vac / 220-230-240Vac										
	Output Voltage Regulation	±10% RMS										
	Output Frequency	50/60Hz ± 0.3Hz										
	Short Circuit Protection	Yes, Current Limit Function (Fault after 1sec)										
	Typical transfer Time	10ms(Max)										
THD	Typically <7%, Max 10% under full linear load											
DC Input	Nominal Input Voltage	12.0Vdc (*2 for 24Vdc, *4 for 48Vdc)										
	Minimum Start Voltage	10.0Vdc										
	Low Battery Alarm	10.5Vdc / 11.0Vdc										
	Low Battery Trip	10.0Vdc / 10.5Vdc										
	High Voltage Alarm & Fault	16.0Vdc										
	High DC Input Recovery	15.5Vdc										
	Low Battery Voltage Recover	13.0Vdc										
	Idle Consumption-Search Mode	< 25 W when Power Saver On										
Charge	Input Voltage Range	Narrow: 100-135VAC / 194-243VAC; Wide: 90-135VAC / 164-243VAC;										
	Input Frequency Range	Narrow: 47-55±0.3Hz for 50Hz, 57-65±0.3Hz for 60Hz Wide:43±0.3Hz plus for 50Hz/60Hz										
	Output Voltage	Depends on battery type										
	Charger Breaker Rating(230Vac)	10A	10A	10A	20A	20A	30A	30A	40A	40A	40A	40A
	Charger Breaker Rating(120Vac)	10A	20A	20A	30A	40A	63A	63A	N/A	N/A	N/A	N/A
	Max Charge Rate	15A to 120A +/-5A , depending on models										
	Over Charge Protection Shutdown	15.7V for 12Vdc (*2 for 24Vdc, *4 for 48Vdc)										
	Battery type	Fast Vdc					Float Vdc					
	Gel U.S.A	14.0					13.7					
	A.G.M 1	14.1					13.4					
	A.G.M 2	14.6					13.7					
Sealed Lead Acid	14.4					13.6						

	Gel Euro	14.4					13.8						
	Open Lead Acid	14.8					13.3						
	Calcium	15.1					13.6						
	De-sulphation	15.5 for 4hrs											
	Remote Control	Yes. Optional											
Bypass & Protection	Input Voltage Waveform	Sine wave (Grid or Generator)											
	Nominal Voltage	120Vac					230Vac						
	Low Voltage Trip	80V/90V ±4%					184V/154V ±4%						
	Low Voltage re engage	90V/100V ±4%					194V/164V ±4%						
	High Voltage Trip	140V ±4%					253V ±4%						
	High Voltage re engage	135V ±4%					243V ±4%						
	Max Input AC Voltage	150VAC					270VAC						
	Nominal Input Frequency	50Hz or 60Hz (Auto detect)											
	Low Freq Trip	Narrow: 47 ±0.3Hz for 50Hz, 57 ±0.3Hz for 60Hz Wide: 40 ±0.3Hz for 50Hz/60Hz											
	Low Freq re engage	Narrow: 48 ±0.3Hz for 50Hz, 58 ±0.3Hz for 60Hz Wide: 45 ±0.3Hz for 50Hz/60Hz											
	High Freq Trip	Narrow: 55 ±0.3Hz for 50Hz, 65 ±0.3Hz for 60Hz Wide: No up limit for 50Hz/60Hz											
	High Freq re engage	Narrow: 54 ±0.3Hz for 50Hz, 64 ±0.3Hz for 60Hz Wide: No up limit for 50Hz/60Hz											
	Output Short circuit protection	Circuit breaker											
	Bypass breaker rating(230Vac)	10A	15A	20A	30A	30A	40A	40A	50A	63A	63A	100A	
Bypass breaker rating(120Vac)	20A	20A	30A	40A	50A	80A	80A	N/A	N/A	N/A	N/A		
Other Features	Auto Generator Start	Available											
	Battery Temp Sensing	Available											
Mechanical Specification	Mounting	Wall mount											
	Inverter Dimensions(L*W*H)	362*173*135mm			505*222*180mm			598*222*180mm		588*415*200mm			706*415*213mm
	Inverter Weight	11KG	13KG	20KG	24KG	29KG	31KG	33KG	60KG	71KG	76KG	85KG	
	Shipping Dimensions(L*W*H)	475*230*205mm			670*320*320mm			780*320*320mm		750*520*310mm			880*545*410mm
	Shipping Weight	13KG	15KG	22KG	26KG	32KG	34KG	36KG	72KG	81KG	86KG	92KG	
	Display	Status LEDs+LCD											
	Standard Warranty	1 Year											

Appendix 2: Circuitry Scheme

Circuitry scheme for Inverter Mode

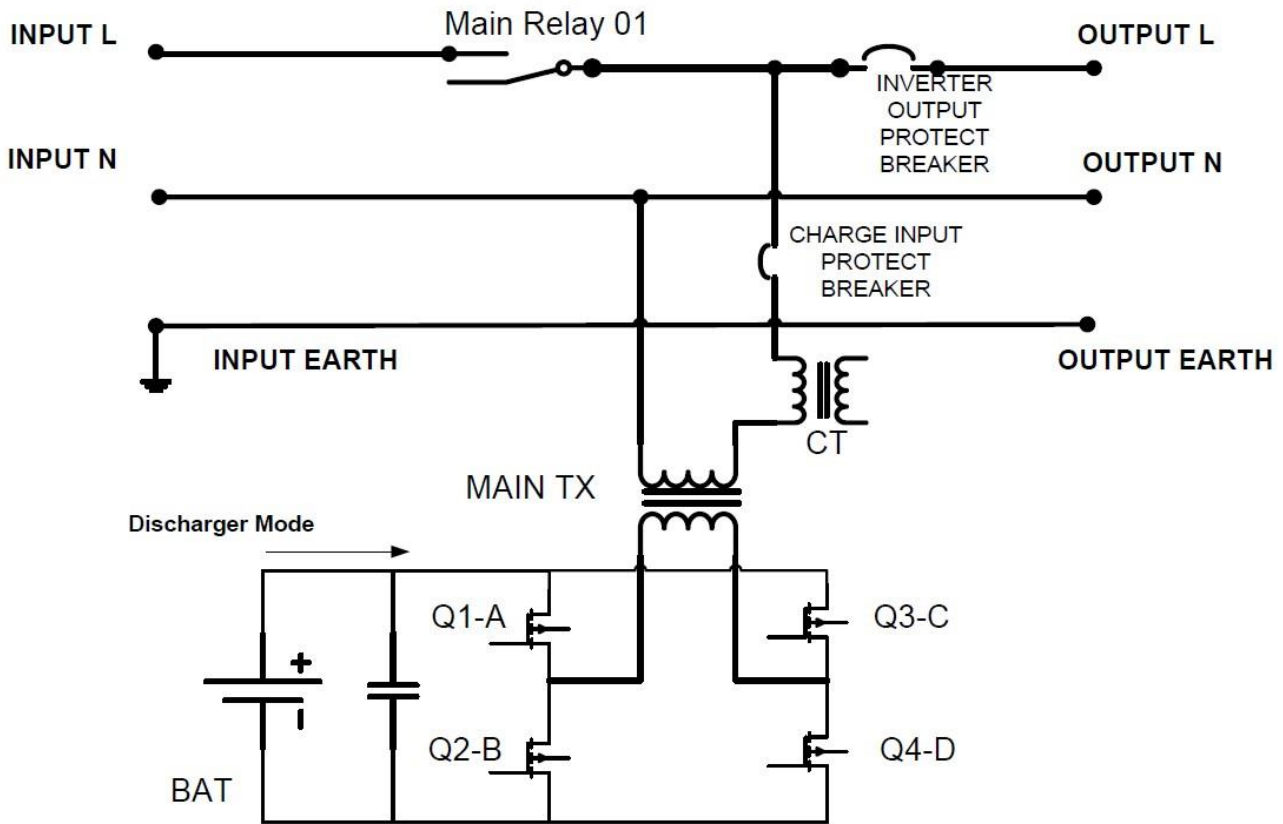

Circuitry scheme for AC Mode

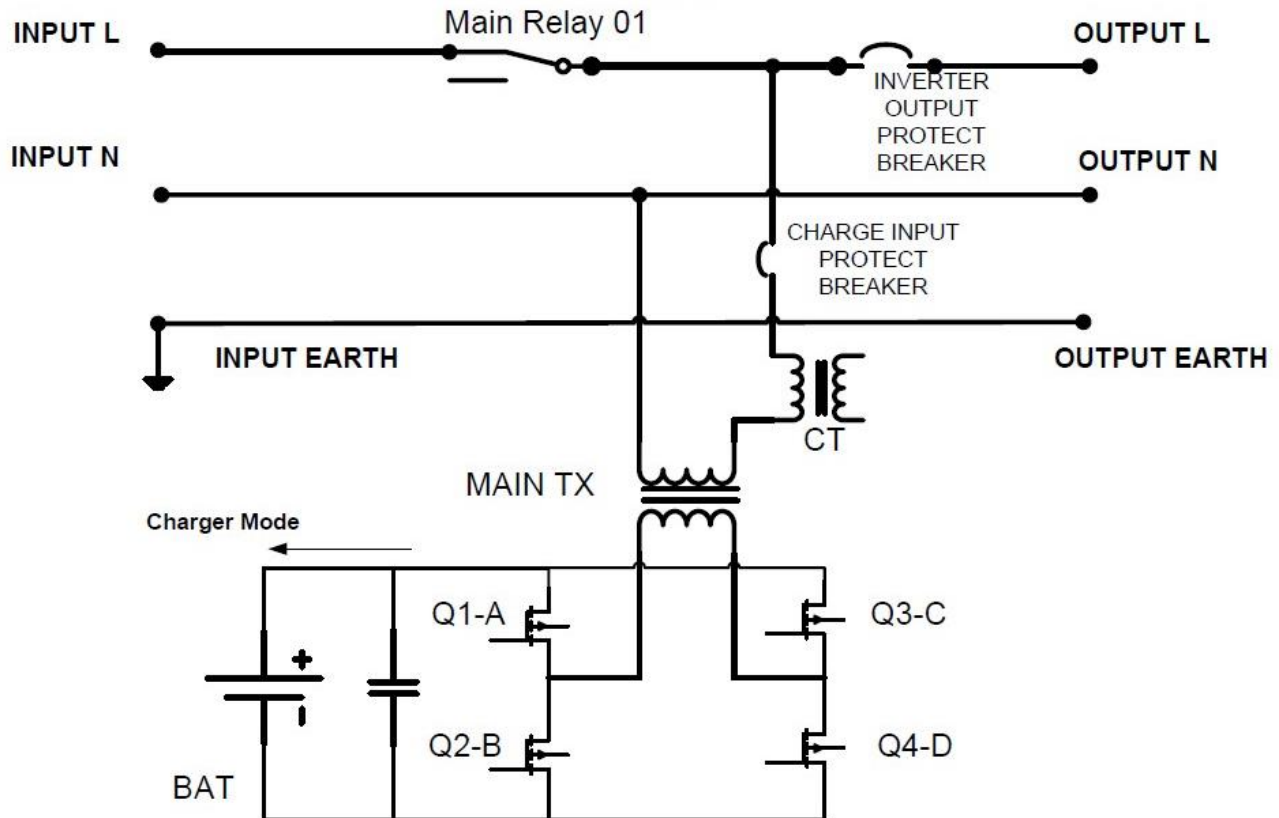

Appendix 3: High Power Inverter/Charger System Wiring Diagram

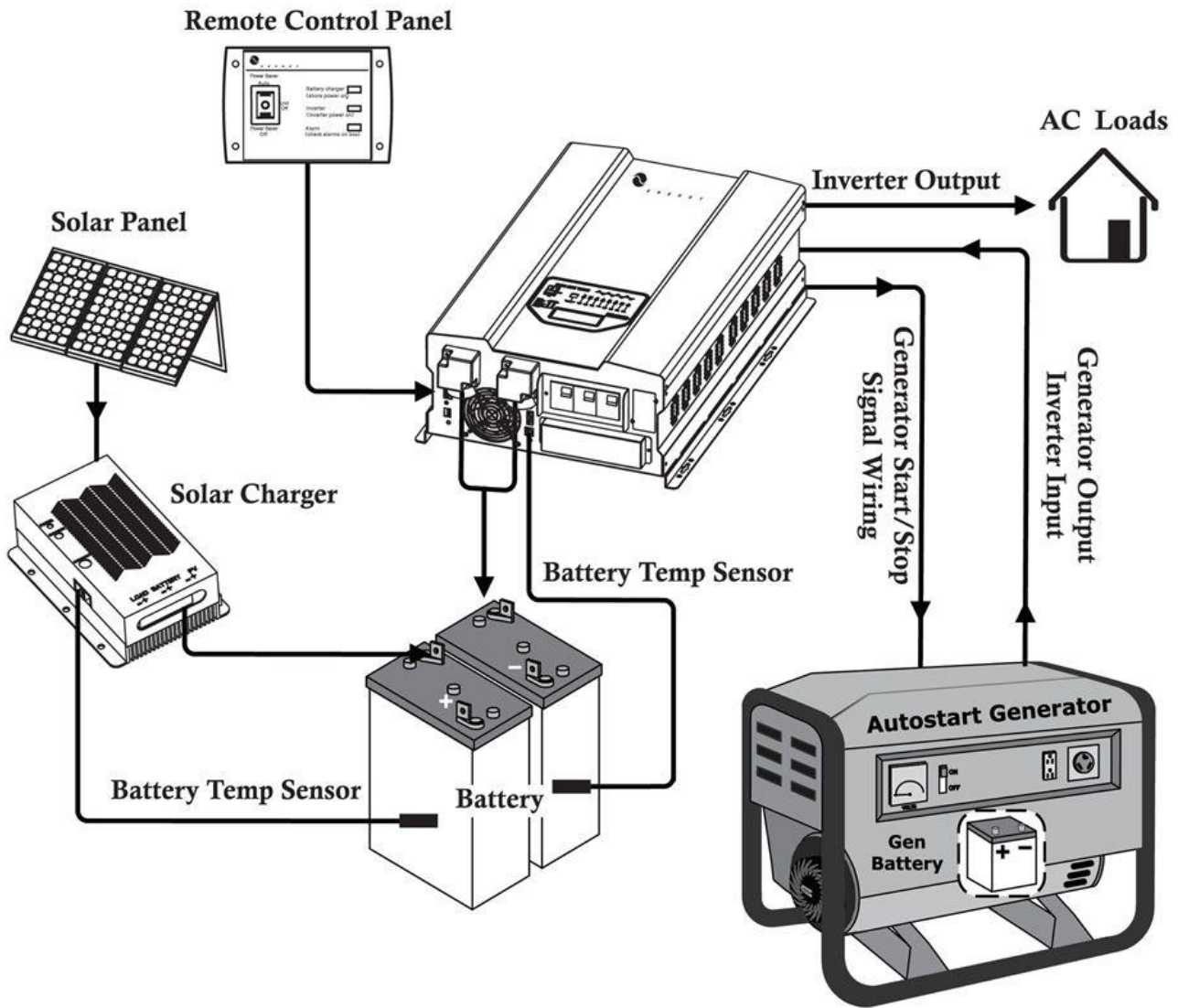

※Errors and omissions reserved. Specifications in this manual are subject to change without prior notice.

SAVE THIS MANUAL!

**READ THIS MANUAL BEFORE INSTALLATION, IT
CONTAINS IMPORTANT SAFETY, INSTALLATION AND
OPERATING INSTRUCTIONS. KEEP IT IN A SAFE PLACE
FOR FUTURE REFERENCE.**

Shenzhen Sigineer Power CO.,LTD.

Email: info@sigineer.com

TEL: +86 755 2160 7078

FAX: +86 755 6165 8278

Add: Bld A, Jiali Industrial Zone, Yuanfen Rd, Longhua, Shenzhen, 518100, China