



# Sigineer Power

## 1.5KW to 6KW Any Power

## Combi

## Pure Sine Wave Inverter/Charger

## User's Manual



**Shenzhen Sigineer Power CO.,LTD.**

**Email: [info@sigineer.com](mailto:info@sigineer.com)**

**TEL: +86 755 2160 7078**

**FAX: +86 755 6165 8278**

**Add: Bld A, Jiali Industrial Zone, Yuanfen Rd, Longhua, Shenzhen, 518100, China**

# Table of Contents

|   |    |
|---|----|
| 1. Important Safety Information .....                         | 3  |
| 1.1 General Safety Precautions .....                          | 3  |
| 1.2 Precautions When Working with Batteries .....             | 3  |
| 2. Introduction .....   | 4  |
| 2.1 General Information.....                                  | 4  |
| 2.2 Application .....   | 5  |
| 2.3 Features .....  | 5  |
| 2.4 Mechanical Drawing.....                                   | 6  |
| 2.5 Electrical Performance .....                              | 8  |
| 2.5.1 Invert .....  | 8  |
| 2.5.2 AC Charger .....  | 9  |
| 2.5.3 Transfer.....   | 12 |
| 2.5.4 Power Saver.....  | 12 |
| 2.5.5 Protections .....                                       | 13 |
| 2.5.6 Remote control.....                                     | 14 |
| 2.5.7 LED Indicator & LCD.....                                | 14 |
| 2.5.8 Audible Alarm .....                                     | 15 |
| 2.5.9 FAN Operation.....                                      | 16 |
| 2.5.10 DIP Switches.....                                      | 16 |
| 2.5.11 Auto Generator Start.....                              | 18 |
| 2.5.12 Battery Temperature Sensing .....                      | 18 |
| 2.5.13 Other features.....                                    | 19 |
| 3 Installation.....   | 20 |
| 3.1 Unpacking and Inspection .....                            | 20 |
| 3.2 Installation Location.....                                | 20 |
| 3.3 DC Wiring .....   | 21 |
| 3.4 AC Wiring .....   | 22 |
| 3.5 Grounding.....  | 23 |
| 3.6 Mounting the Inverter.....                                | 23 |
| 4 Troubleshooting Guide .....                                 | 25 |
| 5 Warranty.....   | 27 |
| Appendix 1 Sigineer Power APC Series Inverter & Charger ..... | 28 |

**Please record the Inverter’s model and serial number in case you need to provide this information in the future. It is much easier to record this information now than try to gather it after inverter has been installed.**

**Model Number:** \_\_\_\_\_

**Serial Number:** \_\_\_\_\_

# 1. Important Safety Information

**Save This Manual! Read this manual before installation, it contains important safety, installation and operating instructions. Keep it in a safe place for future reference.**

**All wiring must follow the National Electric Code, Provincial or other codes in effect at the time of installation, regardless of suggestions in this manual. All wires should be copper conductors.**

## 1.1 General Safety Precautions

1.1.1 Do not expose the Inverter to rain, snow, spray, bilge or dust. To reduce risk of hazard, do not cover or obstruct the ventilation openings. Do not install the Inverter in a zero-clearance compartment. Overheating may result. Allow at least 30CM of clearance around the inverter for air flow. Make sure that the air can circulate freely around the unit. A minimum air flow of 145CFM is required.

1.1.2 To avoid risk of fire and electronic shock, make sure that existing wiring is in good electrical condition and that the wire is not undersized. Do not operate the Inverter with damaged or substandard wiring.

1.1.3 This equipment contains components which may produce arcs and/or sparks. To prevent fire and/or explosion do not install in compartments containing batteries or flammable materials or in a location which require ignition protected equipment. This includes any space containing gasoline-powered machinery, fuel tanks, or joints, fittings, or other connection between components of the fuel system.

See Warranty for instructions on obtaining service.

1.1.4 Do not disassemble the Inverter/Charger. It contains no user-serviceable parts. Attempting to service the Inverter/Charger yourself may result in electrical shock or fire. Internal capacitors remain charged after all power is disconnected.

1.1.5 To reduce the risk of electrical shock, disconnect both AC and DC power from the Inverter/Charger before attempting any maintenance or cleaning. Turning off controls will not reduce this risk

### **CAUTION: Equipment damage**

The output side of the inverter's AC wiring should at no time be connected to public power or a generator. This condition is far worse than a short circuit. If the unit survives this condition, it will shut down until corrections are made.

Installation should ensure that the inverter's AC output is, at no time, connected to its AC input.

## **WARNING: LIMITATIONS OF USE**

SPECIFICALLY, PLEASE NOTE THAT THE INVERTER/CHARGER SHOULD NOT BE USED IN CONNECTION WITH LIFE SUPPORT SYSTEMS OR OTHER MEDICAL EQUIPMENT OR DEVICES. WE MAKE NO WARRANTY OR REPRESENTATION IN CONNECTION WITH THEIR PRODUCTS FOR SUCH USES. USING THE INVERTER/CHARGER WITH THIS PARTICULAR EQUIPMENT IS AT YOUR OWN RISK.

## 1.2 Precautions When Working with Batteries

1.2.1 If battery acid contacts skin or clothing, wash immediately with soap and water. If acid enters eye, immediately flood eye with running cold water and get medical attention immediately.

1.2.2 Never smoke or allow a spark or flame in the vicinity of a battery or engine.

1.2.3 Do not drop a metal tool on the battery. The resulting spark or short-circuit on the battery may cause an explosion.

1.2.4 Remove personal metal items such as rings, bracelets, necklaces, and watches when working with a lead-acid battery. A lead-acid battery produces a short-circuit current high enough to weld a ring or the like to metal, causing a severe burn.

1.2.5 To reduce the risk of injury, charge only deep-cycle lead acid, lead antimony, lead calcium gel cell, absorbed mat, or NiCad/NiFe type rechargeable batteries. Other types of batteries may burst, causing personal injury and damage.

1.2.6 Don't install the inverter near batteries, the inverter may heat battery electrolyte and cause corrosive fumes to vent and damage/corrode nearby electronics or metals.

## 2. Introduction

### 2.1 General Information

Sigineer Power Any Power Combi Pure Sine Wave Inverter/Charger is a combination of an inverter, battery charger and AC auto-transfer switch into one complete system with a peak DC to AC conversion efficiency of 88%.

It is packed with unique features and it is one of the most popular and affordable inverter/chargers in the market today.

It features power factor corrected, sophisticated multi-stage charging and pure sine wave output with unprecedentedly high surge capability to meet demanding power needs of inductive loads without endangering the equipment.

The powerful battery charger of this Any Power Combi Inverter/Charger goes as high as 105Amps (varying on different models), and with power factor corrected, it uses 20-30% less energy from AC input than a standard charger, avoiding nuisance breaker trips or generator overloads.

The overload capacity is 300% of continuous output for up to 20 seconds to reliably support tools and equipment longer.

The idle consumption of the line is low, roughly 4% of its rated power.

These special features make this line compete very well with its high frequency counterparts.

The models are available in 120Vac (single phase), 230Vac (single phase) and 120/240Vac (split phase), together with automatic 50Hz/60Hz frequency switch, the product line is compatible with all the major utility standards worldwide.

This line includes some exclusive 4000 watt 12Vdc models enable vehicle users to power ample loads at a 12VDC battery bank without reconfiguration of their battery bank.

The AC/Battery priority switch and auto generator start functionality make it ideally suitable to work in either backup power or renewable energy applications.

In AC priority mode, when AC power cuts off (or falls out of acceptable range), the transfer relay is de-energized and the load is automatically transferred to the Inverter output. Once the qualified AC power is restored, the relay is energized and the load is automatically reconnected to AC utility.

When customized to Battery Priority Mode via a DIP switch, the inverter will extract maximum power from external power sources in renewable energy systems and a minimal cycle of battery will be required. With the availability of auto generator start, an electrical generator can be integrated into the system as back up and started when the battery voltage goes low.

With audible buzzer and a remote LED display, the inverter gives the users comprehensive information of the operation status, making it easier for maintenance and troubleshooting.

Thus the Sigineer Power APC Series Pure Sine Wave Inverter/Charger is suitable for a myriad of applications including renewable energy systems, utility, truck, RV and emergency vehicles etc.

To get the most out of the power inverter, it must be installed, used and maintained properly. Please read the instructions in this manual before installing and operating.

## 2.2 Application

Power tools—circular saws, drills, grinders, sanders, buffers, weed and hedge trimmers, air compressors.

Office equipment – computers, printers, monitors, facsimile machines, scanners.

Household items – vacuum cleaners, fans, fluorescent and incandescent lights, shavers, sewing machines.

Kitchen appliances – coffee makers, blenders, ice makers, toasters.

Industrial equipment – metal halide lamp, high – pressure sodium lamp.

Home entertainment electronics – television, VCRs, video games, stereos, musical instruments, satellite equipment.

## 2.3 Features

High overload ability up to 300% of rated power (20 sec)

Low quiescent current, low power “Power Saving Mode” to conserve energy

Automatic Generator Start

4-step intelligent battery charger, PFC (Power Factor Correction) for charger

8 pre-set battery type selector switch plus de-sulphation for totally flat batteries

Powerful charge rate of up to 120Amps, selectable from 0%-100%

10 ms typical transfer time between battery and AC, guarantees power continuity

Smart LED remote control panel

AC voltage regulation available

15s delay before transfer when AC resumes, extra protection for loads when used with generator

Allows start up and through power with depleted batteries

Multiple controlled cooling fans

Extensive protections against various harsh situations

13VDC battery recovery point, dedicated for renewable energy systems

## 2.4 Mechanical Drawing

### DC DIDE FOR APC 1KW TO 6KW MODELS

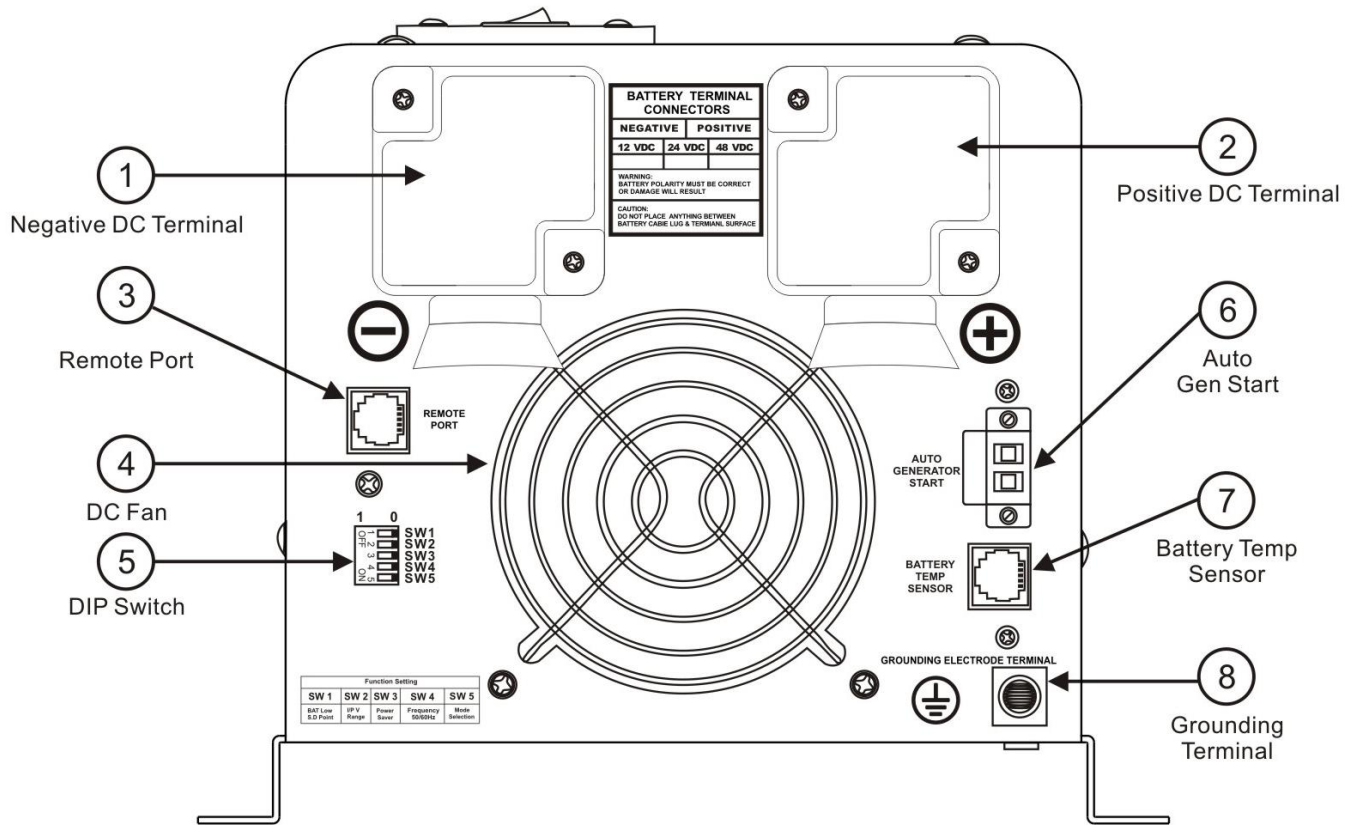

## External Components Introduction

- 1 DC Terminals
- 2 RJ11 Port for Remote Control Panel
- 3 DC Fan
- 4 SW1/SW2/SW3 DIP Switches
- 5 SW4 DIP Switch
- 6 Auto Generator Start Terminal
- 7 Battery Temp Sensor Port
- 8 Grounding Terminal
- 9 Inverter Output Protection Circuit Breaker
- 10 Charger Input Protection Circuit Breaker
- 11 AC Terminal Block
- 12 GFCI (Optional)
- 13 AC Fan



### AC DIDE FOR APC 1KW TO 3KW MODELS

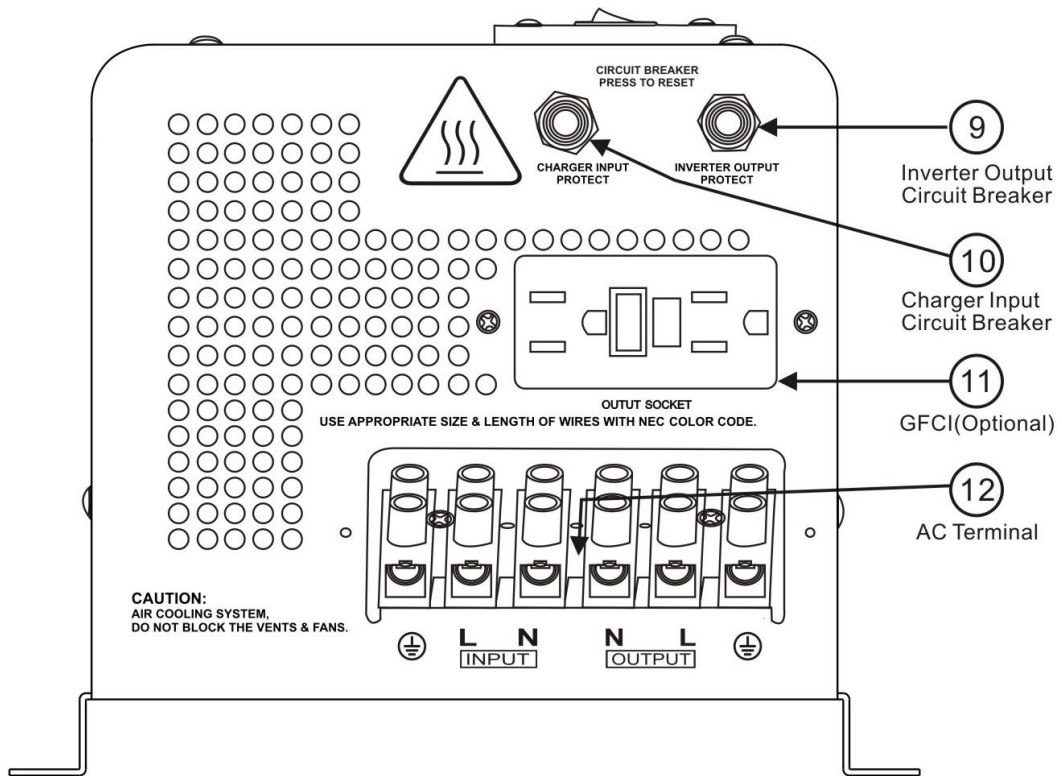

### AC DIDE FOR APC 4KW TO 6KW MODELS

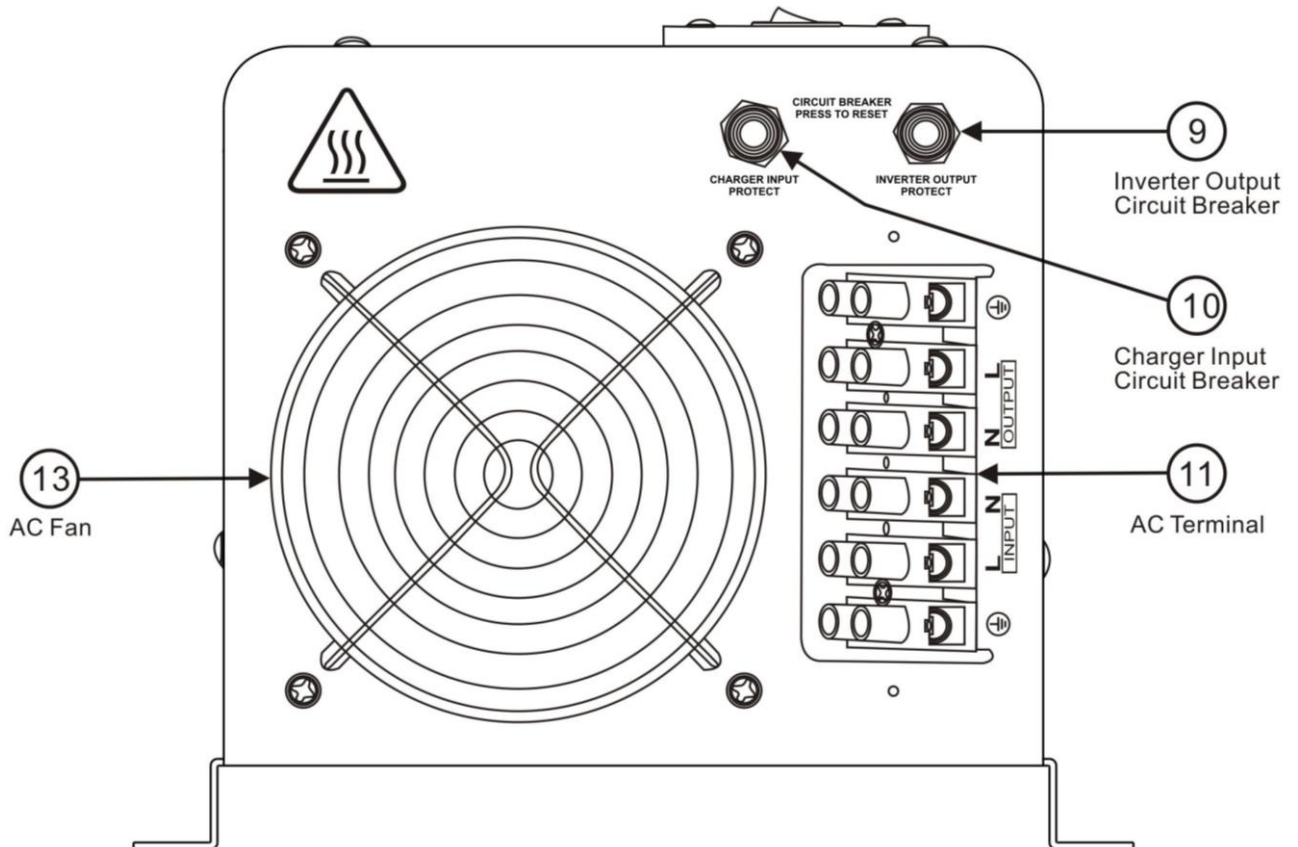

## 2.5 Electrical Performance

### 2.5.1 Invert

#### Topology

The APC inverter/charger is built according to the following topology.

Invert: Full Bridge Topology.

Charge: Isolated Boost Topology.

It works bi-directionally: in one direction it converts DC power from the battery to AC power (Inverter Mode) and in the other direction it converts external AC power to DC power to charge the batteries (AC Mode). The same power components are used in both directions, resulting in high-energy transfer efficiency with fewer components.

Please note that the inverter/charger can only work in one direction at one time (i.e. it can not work as an inverter and as a charger at the same time).

When operating in invert mode, the direct current (DC) that enters the inverter from the batteries is filtered by a large input capacitor and switched “On” and “Off” by the Metal Oxide Silicon Field Effect Transistors (MOSFET) at a rate of 50 Hz or 60Hz, in this step the DC is converted to low voltage synthesized sine wave AC using an H-bridge configuration and high frequency PWM (Pulse Width Modulation) technique. It is then directed into the transformer which steps the low AC voltage up to 230 or 120 volts.

The unit has a 16bit, 4.9MHZ microprocessor to control the output voltage and frequency as the DC input voltage and/or output load varies.

Because of high efficiency MOSFETs and the heavy transformers, it outputs PURE SINE WAVE AC with low THD.

The peak efficiency of Sigineer Power APC Series is 88%.



**Don't parallel the AC output of the inverters to increase power capacity as they have no stacking functionality.**

#### Overload Capacity

The Sigineer Power APC Series inverters have different overload capacities, making it ideal to handle demanding loads.

1 For  $110% < \text{Load} < 125% (\pm 10\%)$ , no audible alarm in 14 minutes, beeps 0.5s every 1s in the 15th minute, and Fault(Turn off) after the 15th minute.

2 For  $125% < \text{Load} < 150% (\pm 10\%)$ , beeps 0.5s every 1s and Fault(Turn off) after the 1 minute.

3 For  $300\% \cong \text{Load} > 150% (\pm 10\%)$ , beeps 0.5s every 1s and Fault(Turn off) after 20s.

#### Soft Start in Inverter Mode

The inverter is engineered with “Soft Start” feature.

When the inverter is turned on, the output voltage gradually ramps up from 0VAC to rated voltage in about 1.2 sec. This effectively reduces otherwise very high starting inrush current drawn by AC loads such as Switched Mode Power Supplies and inductive loads. This will result in lower motor inrush current, which means less impact on the loads and inverter.

#### Caution:

After the inverter is switched on, it takes a finite time for it to self diagnose and get ready to deliver full power. Hence, always switch on the load(s) after a few seconds of switching on the inverter. Avoid



switching on the inverter with the load already switched on. This may prematurely trigger the overload protection. When a load is switched on, it may require initial higher power surge to start. Hence, if multiple loads are being powered, they should be switched on one by one so that the inverter is not overloaded by the higher starting surge if all the loads are switched on at once.

## 2.5.2 AC Charger

Sigineer Power APC Series is equipped with an active PFC (Power Factor Corrected) multistage battery charger. The PFC feature is used to control the amount of power used to charge the batteries in order to obtain a power factor as close as possible to 1.

Unlike other inverters whose max charging current decreases according to the input AC voltage, Sigineer Power APC Series charger is able to output max current as long as input AC voltage is in the range of 164-243VAC(95-127VAC for 120V model), and AC freq is in the range of 48-54Hz(58-64Hz for 60Hz model).

The Sigineer Power APC Series inverter has a very rapid charge current available, and the max charge current can be adjusted from 0%-100% via a liner switch to the right of the battery type selector. This will be helpful if you are using our powerful charger on a small capacity battery bank. Fortunately, the liner switch can effectively reduce the max charging current to 20% of its peak.

Choosing "0" in the battery type selector will disable charging function.

There are 3 main stages:

**Bulk Charging:** This is the initial stage of charging. While Bulk Charging, the charger supplies the battery with controlled constant current. The charger will remain in Bulk charge until the Absorption charge voltage (determined by the Battery Type selection) is achieved.

Software timer will measure the time from A/C start until the battery charger reaches 0.3V below the boost voltage, then take this time as  $T_0$  and  $T_0 \times 10 = T_1$ .

**Absorb Charging:** This is the second charging stage and begins after the absorb voltage has been reached. Absorb Charging provides the batteries with a constant voltage and reduces the DC charging current in order to maintain the absorb voltage setting.

In this period, the inverter will start a  $T_1$  timer; the charger will keep the boost voltage in Boost CV mode until the  $T_1$  timer has run out. Then drop the voltage down to the float voltage. The timer has a minimum time of 1 hour and a maximum time of 12 hours.

**Float Charging:** The third charging stage occurs at the end of the Absorb Charging time. While Float charging, the charge voltage is reduced to the float charge voltage (determined by the Battery Type selection\*). In this stage, the batteries are kept fully charged and ready if needed by the inverter.

If the A/C is reconnected or the battery voltage drops below 12Vdc/24Vdc/48Vdc, the charger will reset the cycle above.

If the charge maintains the float state for 10 days, the charger will deliberately reset the cycle to protect the battery.

# Battery Charging Processes

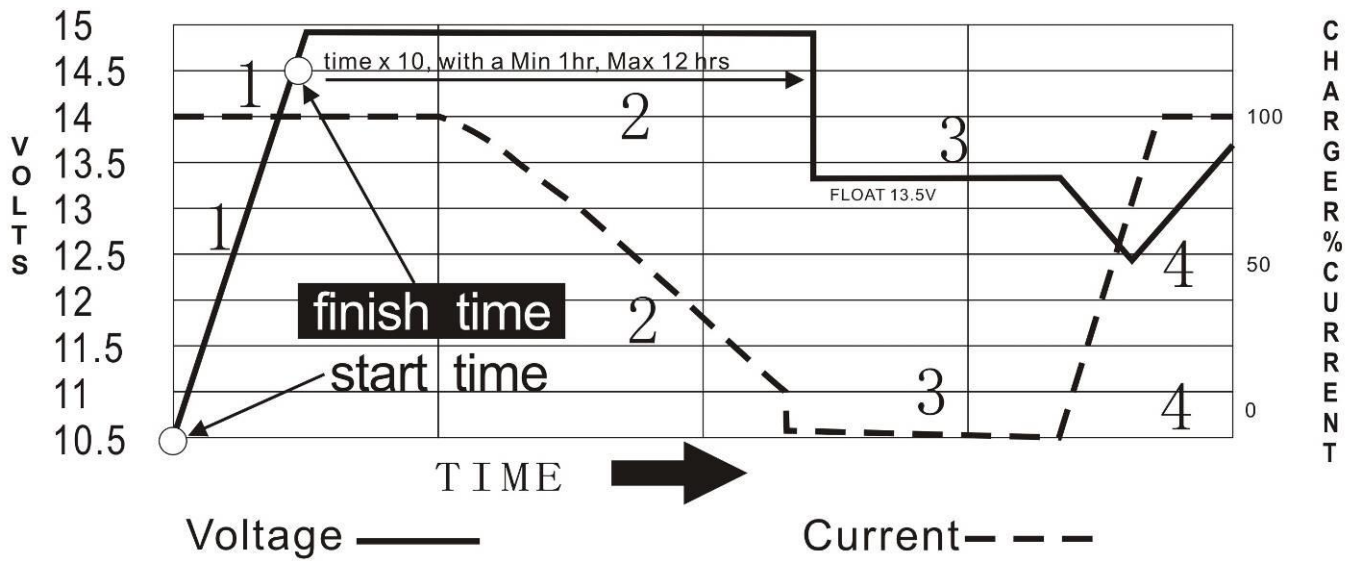

THE NEW BATTERY CHARGERS AND BOOSTERS OFFER THE FASTEST CHARGE RATE CURRENTLY AVAILABLE

STEP 1= Bulk Charge (Constant Current)  
STEP 3= Float Voltage

STEP 2 = Absorption (Constant Voltage)  
STEP 4 = RESET TO STEP 1

\*2 FOR 24 VOLTS  
\*4 FOR 48 VOLTS

ADJUSTABLE TIME DEPENDING ON BATTERY BANK CAPACITY

| Battery type selector |                         |                         |             |
|-----------------------|-------------------------|-------------------------|-------------|
| Switch setting        | Description             | Boost / Vdc             | Float / Vdc |
| 0                     | Charger Off             |                         |             |
| 1                     | Gel USA                 | 14.0                    | 13.7        |
| 2                     | AGM 1                   | 14.1                    | 13.4        |
| 3                     | AGM 2 / Lithium Battery | 14.6                    | 13.7        |
| 4                     | Sealed lead acid        | 14.4                    | 13.6        |
| 5                     | Gel EURO                | 14.4                    | 13.8        |
| 6                     | Open lead acid          | 14.8                    | 13.3        |
| 7                     | Calcium                 | 15.1                    | 13.6        |
| 8                     | De sulphation           | 15.5 (4 Hours then Off) |             |
| 9                     | Not used                |                         |             |

12Vdc Mode (\*2 for 24Vdc ; \*4 for 48Vdc)

## Use with Lithium Ion Battery Packs

“Lithium-ion” refers to a variety of lithium-based battery chemistries. The most popular is the large-format prismatic lithium iron phosphate (LiFePO<sub>4</sub>; LFP) battery.

Our smart battery charger works with various lithium batteries, pls check the battery specs and make sure our charging algorithm suits their charge voltage and cut off voltages.

If our current charging algorithms don't match your lithium battery, welcome to contact us at [info@sigineer.com](mailto:info@sigineer.com) for a customization.

## De-sulphation

The de-sulphation cycle on switch position 8 is marked in red because this is a very dangerous setting if you

do not know what you are doing. Before ever attempting to use this cycle you must clearly understand what it does and when and how you would use it.

What causes sulphation? This can occur with infrequent use of the batteries, nor if the batteries have been left discharged so low that they will not accept a charge. This cycle is a very high voltage charge cycle designed to try to break down the sulphated crust that is preventing the plates from taking a charge and thus allow the plates to clean up and accept a charge once again.

**Charging depleted batteries**

The Sigineer Power APC Series inverter allows start up and through power with depleted batteries.

For 12VDC model, after the battery voltage goes below 10V, if the switch is still (and always) kept in "ON" position, the inverter is always connected with battery, and the battery voltage doesn't drop below 2V, the inverter will be able to charge the battery once qualified AC inputs.

Before the battery voltage going below 9VDC, the charging can activated when the switch is turned to "Off", then to "ON".

When the voltage goes below 9VDC, and you accidently turn the switch to OFF or disconnect the inverter from battery, the inverter will not be able to charge the battery once again, because the CPU lose memory during this process.

Start up without battery function can be customized upon request.

**Charging current for each model**

| Model                                 | Current  | Model        | Current  |
|---------------------------------------|----------|--------------|----------|
| 1KW12V230V                            | 35+/-5A  | 1KW12V120V   | 35+/-5A  |
| 1KW24V230V                            | 20+/-5A  | 1KW24V120V   | 15+/-5A  |
| 1.5KW12V230V                          | 45+/-5A  | 1.5KW12V120V | 50+/-5A  |
| 1.5KW24V230V                          | 25+/-5A  | 1.5KW24V120V | 30+/-5A  |
| 2KW12V230V                            | 65+/-5A  | 2KW12V120V   | 70+/-5A  |
| 2KW24V230V                            | 30+/-5A  | 2KW24V120V   | 30+/-5A  |
| 2KW48V230V                            | 20+/-5A  | 2KW48V120V   | 20+/-5A  |
| 3KW12V230V                            | 85+/-5A  | 3KW12V120V   | 100+/-5A |
| 3KW24V230V                            | 45+/-5A  | 3KW24V120V   | 40+/-5A  |
| 3KW48V230V                            | 30+/-5A  | 3KW48V120V   | 25+/-5A  |
| 4KW12V230V                            | 115+/-5A | 4KW12V120V   | 115+/-5A |
| 4KW24V230V                            | 65+/-5A  | 4KW24V120V   | 50+/-5A  |
| 4KW48V230V                            | 35+/-5A  | 4KW48V120V   | 30+/-5A  |
| 5KW24V230V<br>5KW24V230V(Split Phase) | 70+/-5A  |              |          |
| 5KW48V230V<br>5KW48V230V(Split Phase) | 50+/-5A  |              |          |
| 6KW24V230V<br>6KW24V230V(Split Phase) | 85+/-5A  |              |          |
| 6KW48V230V<br>6KW48V230V(Split Phase) | 60+/-5A  |              |          |

The charging capacity will go to peak charge rate in about 3 seconds. This may cause a generator to drop frequency, making the inverter transfer to battery mode.

It is suggested to gradually put the charging load on the generator by switching the charging switch from min to max. Together with the 15s switch delay our inverter gives the generator enough time to spin up. This will depend on the size of the generator and rate of charge.

As a general Rule, the Bulk Charging Current should be limited to 30% of the capacity of the battery bank. Higher charging current may be used if permitted by the battery manufacturer.

|  |   |
|--|---|
| <br><b>Caution:</b> | <p><b>Please use a small jeweler’s style flat-head screwdriver to turn the charge current control switch gently to avoid breakage due to over-turning.</b></p> <p><b>To guarantee the best performance of AC charger when the AC input is from a generator, the standby generator should be of at least 150% higher capacity than the inverter.</b></p> <p><b>Warning! Operation with an under-rated generator or generator with unqualified wave form may cause premature failure which is not under warranty.</b></p> |
|--|---|

### 2.5.3 Transfer

#### Swift Power Transfer

While in the Standby Mode, the AC input of the inverter is continually monitored. Whenever AC power falls below the low AC voltage trip voltage (154 Vac, default setting for 230VAC,90VAC for 120VAC), the inverter automatically transfers back to the Invert Mode with minimum power interruption to your appliances - as long as the inverter is turned on. The transfer from Standby mode to Inverter mode occurs in approximately 10 milliseconds. And it is even shorter from Inverter mode to Standby mode.

This transfer time is usually fast enough to keep your equipment (including computers) powered up, thus our inverter can be used as a line interactive UPS.

#### Synchronized Power Transfer

When a load is transferred from inverter AC output to another backup AC source of power through a transfer switch, there will be a finite interruption of power to the load for the transfer to take place.

A mismatch of phase and frequency of the inverter AC output and the backup AC source in transfer is likely to damage the backup AC source / a reactive load.

With sophisticated circuitry design, our inverter will first lock on the frequency and phase of the input shore power/generator power and make a smooth and safe transfer at the zero voltage point to minimize the impact on the power modules.

#### Transfer Delay

There is a 15-second delay from the time the inverter senses that continuously qualified AC is present at the input terminals to when the transfer is made. This delay is built in to provide sufficient time for a generator to spin-up to a stable voltage and frequency and avoid relay chattering. The inverter will not transfer to generator until it has locked onto the generator’s output. This delay is also designed to avoid frequent switching when input utility is unstable.

### 2.5.4 Power Saver

There are 2 different working statuses for APC inverter: “Power On” and “Power Off”.

When power switch is in “Unit Off” position, the inverter is powered off.

When power switch is turned to either of “Power Saver Auto” or “Power Saver Off”, the inverter is powered on.

Power saver function is dedicated to conserve battery power when AC power is not or little required by the loads.

In this mode, the inverter pulses the AC output looking for an AC load (i.e., electrical appliance). Whenever an AC load (greater than 25 watts) is turned on, the inverter recognizes the need for power and automatically starts inverting and output goes to full voltage. When there is no load (or less than 25 watts) detected, the inverter automatically goes back into search mode to minimize energy consumption from the battery bank.

In “Power saver on” mode, the inverter will draw power mainly in sensing moments, thus the idle consumption is significantly reduced.

The inverter is factory defaulted to detect load for 250ms in every 30 seconds. This cycle can be customized to 3 seconds thru the SW3 on DIP switch.

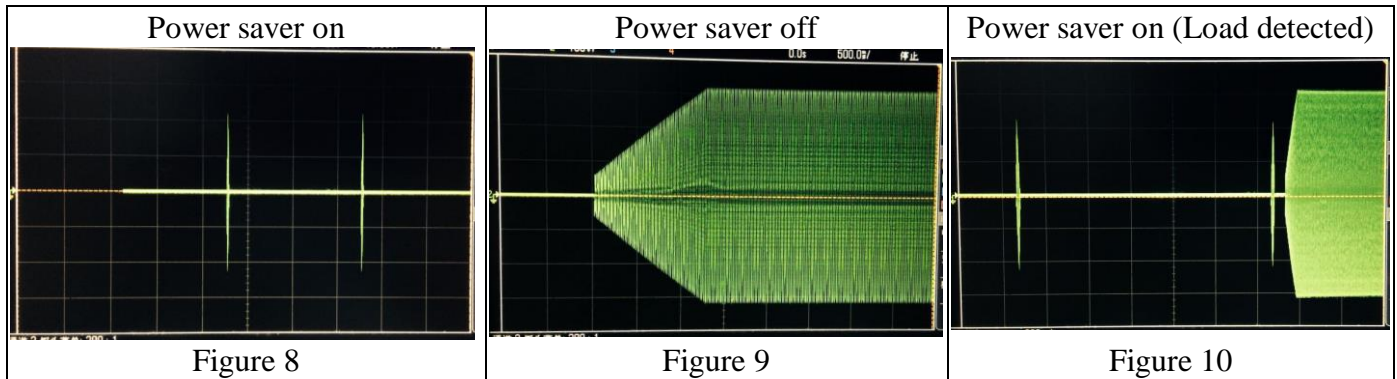

Note: The minimum power of a load to take inverter out of sleep mode (Power Saver On) is 50 Watts. For split phase models, the power threshold of sleep mode is 50W between Hot1 and Neutral and 200W between Hot 1 and Hot 2. There is no load detection between Hot2 and Neutral.

Note: The minimum power of a load to take inverter out of sleep mode (Power Saver On) is 25 Watts.

The Sigineer Power APC Series is designed with extraordinarily low idle power consumption which is only a mere 0.8-1.8% of its rated power.

When in the search sense mode, the green power LED will blink and the inverter will make a ticking sound. At full output voltage, the green power LED will light steadily and the inverter will make a steady humming sound. When the inverter is used as an “uninterruptible” power supply the search sense mode function should be defeated.

### Exceptions

Some devices when scanned by the load sensor cannot be detected. Small fluorescent lights are the most common example. (Try altering the plug polarity by turning the plug over.) Some computers and sophisticated electronics have power supplies that do not present a load until line voltage is available. When this occurs, each unit waits for the other to begin. To drive these loads either a small companion load must be used to bring the inverter out of its search mode, or the inverter may be programmed to remain at full output voltage.

## 2.5.5 Protections

The Sigineer Power APC Series inverter is equipped with extensive protections against various harsh situations/faults.

These protections include:

AC Input over voltage protection/AC Input low voltage protection

Low battery alarm/High battery alarm  
Over temperature protection/Over load protection  
Short Circuit protection (1s after fault)  
Back feeding protection

When Over temperature /Over load occur, after the fault is cleared, the master switch has to be reset to restart the inverter.

The Low battery voltage trip point can be customized from defaulted value of 10VDC to 10.5VDC through the SW1 on the DIP switch.

The inverter will go to Over temp protection when the heat sink temp.  $\geq 105$  °C(221°F), and will go to Fault (shutdown Output) after 30 seconds. The switch has to be reset to activate the inverter.

The Sigineer Power APC Series Inverter is with back feeding protection which avoids presenting an AC voltage on the AC input terminal in Invert mode.

After the reason for fault is cleared, the inverter has to be reset to start working.

## 2.5.6 Remote control

Apart from the switch panel on the front of the inverter, an extra LED or LCD switch panel connected to the remote port at the DC side of the inverter through a RJ11 or RJ45 cable can also control the operation of the inverter.

If an extra switch panel is connected to the inverter via “remote control port”, together with the master switch panel on the inverter case, the two panels will be connected and operated in parallel, whichever first switches from “Unit Off” to “Power saver off” or “Power saver on”, it will power the inverter on.

If the commands from the two panels conflict, the inverter will accept command according to the following priority:

Power saver on > Power saver off > Power off

Only when both panels are turned to “Unit Off” position, will the inverter be powered off.



### **WARNING**

Never cut the telephone cable when the cable is attached to inverter and battery is connected to the inverter. Even the inverter is turned off, this will damage the remote PCB inside if the cable is short circuited during cutting.

## 2.5.7 LED Indicator & LCD

The operation status of the inverter is shown by the LED's and the explanation on the LED sticker.



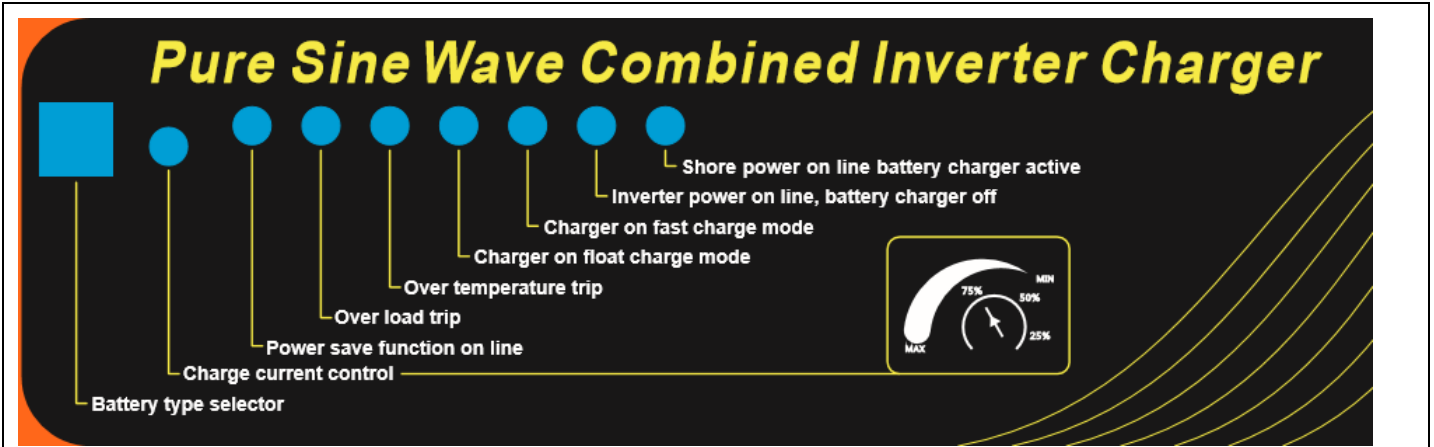

|                |   |
|----------------|---|
| SHORE POWER ON | GREEN LED lighting on AC Mode   |
| INVERTER ON    | GREEN LED lighting on Inverter Mode                                   |
| FAST CHARGE    | Yellow LED lighting on Fast Charging Mode                             |
| FLOAT CHARGE   | GREEN LED lighting on Float Charging Mode                             |
| OVER TEMP TRIP | RED LED lighting on Over Temperature                                  |
| OVER LOAD TRIP | RED LED lighting on Over Load   |
| POWER SAVER ON | GREEN LED lighting on Power Saver Mode (Power Saver Load $\leq 25W$ ) |

The inverter can be connected to a remote LCD control panel.

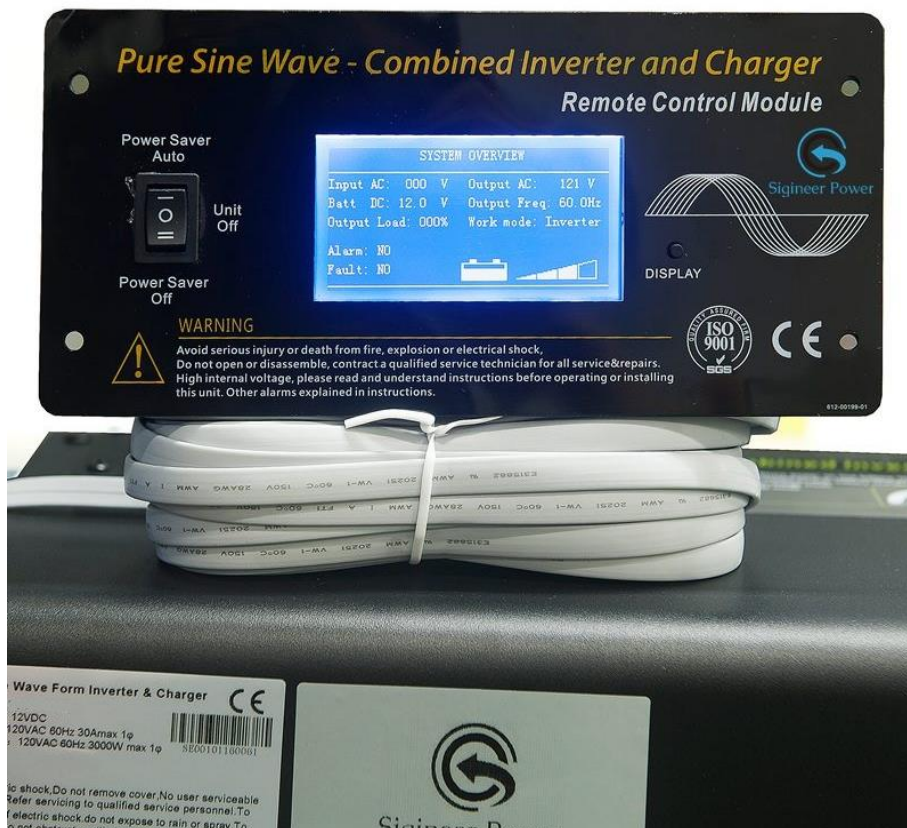

### 2.5.8 Audible Alarm

The inverter also gives audible alarms when the following situations occur.

|                             |   |
|-----------------------------|---|
| <b>Battery Voltage Low</b>  | Inverter green LED Lighting, and the buzzer beep 0.5s every 5s. |
| <b>Battery Voltage High</b> | Inverter green LED Lighting, and the buzzer beep 0.5s every 1s, |

|                              |   |
|------------------------------|---|
|                              | and Fault after 60s.  |
| <b>Invert Mode Over-Load</b> | (1)110% <load<125% ( $\pm 10\%$ ), No audible alarm in 14 minutes, Beeps 0.5s every 1s in 15 <sup>th</sup> minute and Fault after 15 minutes;<br>(2)125% <load<150% ( $\pm 10\%$ ), Beeps 0.5s every 1s and Fault after 60s;<br>(3)Load>150% ( $\pm 10\%$ ), Beeps 0.5s every 1s and Fault after 20s; |
| <b>Over Temperature</b>      | Heat sink temp. $\geq 105^{\circ}\text{C}$ (221 $^{\circ}\text{F}$ ), Over temp red LED Lighting, beeps 0.5s every 1s;  |

## 2.5.9 FAN Operation

For 1-3KW, there is one multiple controlled DC fan which starts to work according to the following logics. For 4-6KW, there is one multiple controlled DC fan and one AC fan. The DC fan will work in the same way as the one on 1-3KW, while the AC fan will work once there is AC output from the inverter. So when the inverter is in power saver mode, the AC fan will work from time to time in response to the pulse sent by the inverter in power saver mode.

The Operation of DC fan at the DC terminal side is controlled in the following logic:

| Condition                         | Enter Condition                                       | Leave condition                                       | Speed |
|-----------------------------------|---|---|-------|
| <b>HEAT SINK TEMPERATURE</b>      | $T < 85^{\circ}\text{C}$ (185 $^{\circ}\text{F}$ )    | $T \geq 85^{\circ}\text{C}$ (185 $^{\circ}\text{F}$ ) | 50%   |
|                                   | $T \geq 85^{\circ}\text{C}$ (185 $^{\circ}\text{F}$ ) | $T < 80^{\circ}\text{C}$ (176 $^{\circ}\text{F}$ )    | 100%  |
| <b>CHARGER CURRENT</b>            | $I \leq 50\%\text{Max}$                               | $I > 50\%\text{Max}$                                  | 50%   |
|                                   | $I > 50\%\text{Max}$                                  | $I \leq 40\%\text{Max}$                               | 100%  |
| <b>LOAD Percentage (INV MODE)</b> | Load < 50%  | Load $\geq 50\%$                                      | 50%   |
|                                   | Load $\geq 50\%$                                      | Load $\leq 40\%$                                      | 100%  |

Allow at least 30CM of clearance around the inverter for air flow. Make sure that the air can circulate freely around the unit.

Fan noise level <60db at a distance of 1m

## 2.5.10 DIP Switches

On the DC end of inverter, there are five DIP switches which enable users to customize the performance of the device.

| Switch #              | Switch Function            | Position: 0          | Position: 1                 |
|-----------------------|----------------------------|----------------------|-----------------------------|
| SW1(AC Priority)      | Low Battery Trip Point     | 10.0VDC              | 10.5VDC                     |
| SW1(Battery Priority) |                            | 10.5VDC              | 11.5VDC                     |
| SW2(230Vac)           | AC Input Range             | 176-242Vac $\pm 4\%$ | 160-264Vac(40Hz+) $\pm 4\%$ |
| SW2(120Vac)           | AC Input Range             | 100-135Vac $\pm 4\%$ | 90-135Vac(40Hz+) $\pm 4\%$  |
| SW3                   | Power Save Override ON/OFF | Inverter Off         | Power Saver On( 3 sec)      |
| SW4                   | Frequency Switch           | 50Hz                 | 60Hz                        |
| SW5                   | Battery/AC Priority        | AC Priority          | Battery Priority            |

**Low Battery Trip Point (SW1):**

Deep discharge of the lead acid battery leads to high losses in capacity and early aging. In different applications a different low voltage disconnection level is preferred. For example, for solar applications, user may intend to have less DOD to prolong the battery life cycle. While for mobile applications users may intend to have more DOD to reduce battery capacity and on board weight.

For 12VDC models, when the inverter is in AC priority mode (SW5 at “0”), Low Battery Trip Point is selectable at 10.0/10.5VDC. It can be customized to 10.5/11.5Vdc via SW5. This is to prevent batteries from over-discharging while there is only a small load applied on the inverter.

\*2 for 24VDC, \*4 for 48VDC

### **AC Input Range (SW2):**

There are different acceptable AC input ranges for different kinds of loads.

For some relatively sensitive electronic devices, a narrow input range of 176-242VAC (100-135V for 120Vac models) is required to protect them.

While for some resistive loads which work in a wide voltage range, the input AC range can be customized to 160-264VAC (90-135V for 120Vac models), this helps to power loads with the most AC input power without frequent switches to the battery bank.

In order to make the inverter accept dirty power from a generator, when the SW2 is switched to position “1”, the inverter will bypass an AC input with a wider voltage and frequency (40Hz plus for 50Hz/60Hz).

Accordingly, the AC charger will also work in a wider voltage and freq range (43Hz plus for 50Hz/60Hz).

This will avoid frequent switches between battery and generator. But some sensitive loads will suffer from the low quality power.

The pros and cons should be clearly realized.

### **Power Save Override ON/OFF (SW3):**

Under the Battery Priority Mode (SW5 in position “1”), the inverter can be switched between two modes: Power Saver Mode (SW3 in position “1”) and Unit Off Charging Mode (SW3 in position “0”). The power Switch should be in “Power saver on” position all the time for using these functions.

In Power Saver Mode, the inverter is initially in standby mode and sends a pulse to detect the presence of a load every 3 seconds. Each pulse lasts for 250ms. The inverter will remain in standby mode until a load has been detected. Then it will wake up from standby mode and start to invert electricity from the battery bank to supply the load. As this function is under Battery Priority, the inverter will always prefer to invert electricity from battery first even there is a qualified AC input present. Only when the battery voltage is lower than the low voltage alarm point, will the inverter switch to AC input power to charge the battery and supply the load at the same time.

This Power Saver Mode can be changed to Unit Off Charging mode via SW3 by switching it to “0” position (SW5 still in “1”).

“Unit Off Charging” will enable the inverter charger to charge batteries as much as possible while without discharging them.

In “Unit Off Charging” mode, the inverter will stay in standby mode without sensing loads. It won't output any power even if a load is turned on, and only stay idle in this mode when there is no AC input.

When a qualified AC input is present, it will start charging the battery and transfer power to loads.

This feature is ideally suitable for applications where energy conservation for batteries is required.

Charging will be activated once qualified AC exists, while discharging is disabled.

The inverter only consumes as little as 3 watts in “Unit Off Charging” mode.

### **Output Frequency:**

The output frequency of the inverter can be set at either 50Hz or 60Hz by SW4 which make the inverter charger an international models for most electricity systems.

### **AC/Battery Priority (SW5):**

Our inverter is designed with AC priority by default. This means, when AC input is present, the battery will be charged first, and the inverter will transfer the input AC to power the load. Only when the AC input is stable for a continuous period of 15 days will the inverter start a battery inverting cycle to protect the battery. After 1 normal charging cycle ac through put will be restored.

The AC Priority and Battery Priority switch is SW5. When you choose battery priority, the inverter will invert from battery despite the AC input. Only when the battery voltage reaches the low voltage alarm point(10.5Vdc for 12Vdc, 21Vdc for 24Vdc, 42Vdc for 48Vdc), will the inverter transfer to AC input, charge battery, and switch back to battery when the battery is fully charged. This function is mainly for wind/solar systems using utility power as back up.

**Note: In battery priority mode, when qualified AC inputs for the first time and the battery voltage is below 12.5Vdc (12.5Vdc for 12Vdc, 25Vdc for 24Vdc, 51Vdc for 48Vdc), the inverter will go into battery priority mode only after a cycle of bulk charging and absorb charging is finished. The inverter will not go into float charging mode.**

### **2.5.11 Auto Generator Start**

The inverter can start up generator when battery voltage goes low.

When the inverter goes to low battery alarm, it can send a signal to start a generator and turn the generator off after battery charging is finished.

The auto gen start feature will only work with generators which have automatic starting capability. The generator must have start and stop controls [i.e., an electric starter and electric choke (for gasoline units)], and the safety sensors to be able to start and stop automatically.

There is an open/close relay that will short circuit the positive and negative cables from a generator start control.

The input DC voltage can vary, but the max current the relay can carry is 16Amp.

The Auto Generator Start terminal pins are not polarized.

In addition, these two pins can also be used as dry contacts to send out “Low Battery Voltage” signal to an external alarm device.

### **2.5.12 Battery Temperature Sensing**

Applying the proper charge voltage is critical for achieving optimum battery performance and longevity. The ideal charge voltage required by batteries changes with battery temperature.

The battery temperature sensor allows the charge controller to continuously adjust charge voltage based on actual battery temperature.

Temperature compensation of charge voltage assures that the battery receives the proper charge voltage as battery temperature varies.

The entire line is equipped with Battery Temperature Sensing for increased charging precision.

It sends precise information to the charger, which automatically adjusts voltage to help ensure full battery charge depending on the ambient temperature of your battery installation.

When the battery voltage is over 40°C (104°F), it will reduce the charging voltage by 0.1Vdc with every degree of temperature rise.

We recommend that you install Battery Temperature Sensors on all banks to protect your batteries and to provide optimal charging of each bank.

The battery temperature sensor mounts on the side of a battery or any other location where the precise temperature of battery can be detected such as battery mounting racks.

The following table describes approximately how much the voltage may vary depending on the temperature of the batteries.

| Inverter Condition | Temperature on BTS  | Charger Operation                               |
|--------------------|---|---|
| Charger Mode       | $BTS \geq 50^{\circ}C (122^{\circ}F)$                                 | Automatically turns off charger                 |
|                    | $BTS \leq 40^{\circ}C (104^{\circ}F)$                                 | Automatically turns on charger                  |
| Inverter Mode      | $40^{\circ}C (104^{\circ}F) \leq BTS \leq 50^{\circ}C (122^{\circ}F)$ | Increases low voltage shut down point by 0.5Vdc |
|                    | $BTS \geq 50^{\circ}C (122^{\circ}F)$                                 | Over Temp Fault                                 |

|   |  |
|---|--|
| <p>A Battery Temperature Sensor has been provided as a separate accessory. It comes with 32.8'/10m cable.</p> |  |
|---|--|

**Important:** If the battery temperature is allowed to fall to extremely cold temperatures, the inverter with a BTS may not be able to properly recharge cold batteries due to maximum voltage limits of the inverter. Ensure the batteries are protected from extreme temperatures. For more detailed technical information, please contact us.

### 2.5.13 Other features

#### Battery voltage recovery start

After low battery voltage shut off(10V for 12V model or 20V for 24V model or 40V for 48V model), the inverter is able to restore to work after the battery voltage recovers to 13V/26V/52V(with power switch still in “On” position). This function helps to save the users extra labor to reactivate the inverter when the low battery voltage returns to acceptable range in renewable energy systems.



#### WARNING

Never leave the loads unattended, some loads (like a Heater) may cause accidents in such cases. It is better to shut everything off after low voltage trip than to leave your load in the risk of fire. Nobody wants to return home, finding house surrounded by fire trucks, and naughty neighborhood kids toasting hot dogs against his house.

#### Auto Gen Start

The inverter can be customized to start up a generator when battery voltage goes low. When the inverter goes to low battery alarm, it can send a signal to start a generator, and turn the generator off after battery charging is finished.

The auto gen start feature will only work with generators designed to work with this feature. There is an open/close relay that will short circuit the positive and negative cable from a generator. The input DC voltage can vary, but the Max current the relay can carry is 16Amp.

#### Conformal Coating

The entire line of inverters have been processed with a conformal coating on the PCB, making it water, rust, and dust resistant.



While these units are designed to withstand corrosion from the salty air, they are not splash proof.

## 3 Installation

### 3.1 Unpacking and Inspection

Carefully remove the inverter/charger from its shipping package and inspect all contents.

Verify the following items are included:

- The Inverter/Charger
- Red and black DC terminal covers
- AC terminal block cover with two Phillips screws
- Two Flange nuts and 4 M8 Phillips screws (installed on the DC terminals).
- One Owner's Manual

If items appear to be missing or damaged, contact our authorized dealer or us. If at all possible, keep your shipping box. It will help protect your inverter from damage if it ever needs to be returned for service. Save your proof-of-purchase as a record of your ownership; it will also be needed if the unit should require warranty work.

### 3.2 Installation Location

Follow all the local regulations to install the inverter.

Please install the equipment in an INDOOR location of Dry, Clean, Cool with good ventilation.

Working temperature: -10°C to 40°C (-14°F to 104°F)

Storage temperature: -40 to 70°C (-40°F to 158°F)

Relative Humidity: 0% to 95%, non-condensing

Cooling: Forced air

**CAUTION:** Some models of the inverters are heavy. Use proper lifting techniques during installation to prevent personal injury.



#### **WARNING!**

The inverter should not be installed in an area that allows dust, fumes, insects or rodents to enter or block the inverter's ventilation openings.

This area also must be free from any risk of condensation, water or any other liquid that can enter or fall on the inverter.

The entire line of inverters has been processed with a conformal coating on the PCB, making it water, rust, and dust resistant.

While these units are designed to withstand corrosion from the salty air, they are not splash proof.

The inverter's life is uncertain if used in these types of environments, and inverter failures under these conditions are not covered under warranty.



### 3.3 DC Wiring

It is suggested the battery bank be kept as close as possible to the inverter. The following is a suggested wiring option for 3 meter DC cable.

Please find the following minimum wire size. In case of DC cable longer than 3m, please increase the cross section of cable to reduce the loss.

Please follow the above minimum wire size requirement.

One cable is always best, but if there is a problem obtaining the recommended size or larger cable, multiple smaller cables will work. Performance of any product can be improved by thicker cable and shorter runs, so if in doubt round up and keep the length as short as possible.

Battery cables must have crimped (or preferably, soldered and crimped) copper compression lugs unless aluminum mechanical lugs are used. Soldered connections alone are not acceptable. High quality, UL-listed battery cables are available. These cables are color-coded with pressure crimped, sealed ring terminals.

Battery terminal must be clean to reduce the resistance between the DC terminal and cable connection. A buildup of dirt or oxidation may eventually lead to the cable terminal overheating during periods of high current draw. Use a stiff wire brush and remove all dirt and corrosion from the battery terminals and cables.

| Power | DC Input voltage | Wire Gage |
|-------|------------------|-----------|
| 1KW   | 12V              | AWG 4     |
| 1KW   | 24V              | AWG 6     |
| 1.5KW | 12V              | AWG 1/0   |
| 1.5KW | 24V              | AWG 4     |
| 2KW   | 12V              | AWG 1/0   |
| 2KW   | 24V              | AWG 1/0   |
| 2KW   | 48V              | AWG 6     |
| 3KW   | 12V              | AWG 4/0   |
| 3KW   | 24V              | AWG 1/0   |
| 3KW   | 48V              | AWG 4     |
| 4KW   | 24V              | AWG 1/0   |
| 4KW   | 48V              | AWG 1/0   |
| 5KW   | 24V              | AWG 4/0   |
| 5KW   | 48V              | AWG 1/0   |
| 6KW   | 24V              | AWG 4/0   |
| 6KW   | 48V              | AWG 1/0   |

Do not place anything between battery cable lug and terminal surface.  
Assemble exactly as shown.

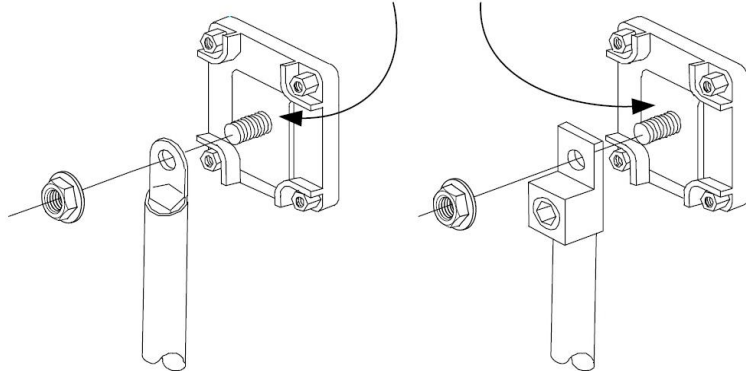

Copper Compression Lug

Aluminum Mechanical Lug

#### Reducing RF interference

To reduce the effect of radiated interference, twist the DC cables. To further reduce RF interference, shield the cables with sheathing /copper foil / braiding.

#### Taping battery cables together to reduce inductance

Do not keep the battery cables far apart. In case it is not convenient to twist the cables, keep them taped together to reduce their inductance. Reduced inductance of the battery cables helps to reduce induced voltages. This reduces ripple in the battery cables and improves performance and efficiency.

|   |  |
|---|--|
|  | The torque rating range for DC terminal is 12.5NM-20.5NM (9.25-15.19 pound-foot), and the suggested torque rating is 17NM (12.6 pound-foot). Over torquing may break the bolt. |
|---|--|

|                |   |
|----------------|---|
| <b>WARNING</b> | <b>Equipment Damage</b><br>The inverter is not reverse polarity protected. Reversing the battery polarity on the DC input connections will cause permanent damage to the inverter which is not covered under warranty. Always check polarity before making connections to the inverter. |
|                | The inverter contains capacitors that may produce a spark when first connected to battery. Do not mount in a confined compartment with vented battery or gases.   |
|                | Ensure the inverter is off before disconnecting the battery cables, and that AC power is disconnected from the inverter input.  |

### 3.4 AC Wiring

We recommend using 10 to 5Awg wire to connect to the ac terminal block.

When in AC mode the AC input power will supply both the loads and AC charger, a thicker wire gauge for AC Input is required. Pls consult a qualified electrician about the specific wire gauge required in terms of wire material and inverter power.

There are 3 different ways of connecting to the terminal block depending on the model. All the wirings are CE compliant, Call our tech support if you are not sure about how to wire any part of your inverter.

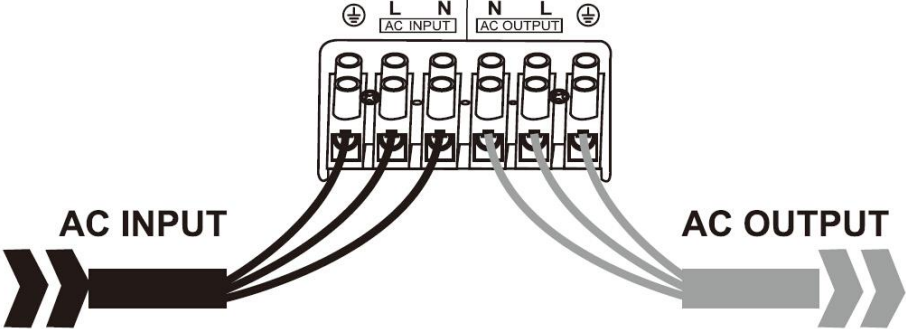
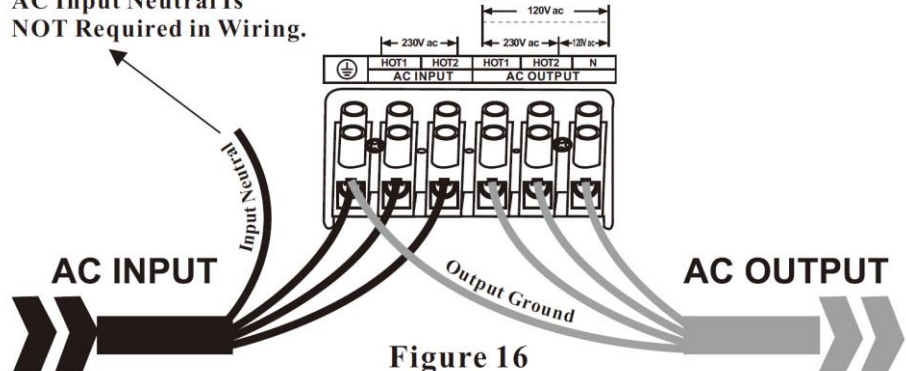
|  |   |
|--|---|
| <p><b>Wiring Option 1</b></p> <p>230V single phase/120V single phase<br/>                 Input: Ground+Hot line+Neutral<br/>                 Output: Neutral+ Hot line+Ground</p> |  <p style="text-align: center;"><b>Figure 15</b></p>   |
| <p><b>Wiring Option 2</b></p> <p>120/240V split phase<br/>                 Input: Ground + Hot line+ Hot line<br/>                 Output: Hot line+ Hot line +Neutral</p>         | <p>AC Input Neutral Is NOT Required in Wiring.</p>  <p style="text-align: center;"><b>Figure 16</b></p> |

**Wiring Option 3**

120/240V split phase

Input: Ground + Hot line+ Hot line

Output: Hot line +Neutral

Remark: In such case, each 120Vac output hotline can only carry a max of half the rated capacity.

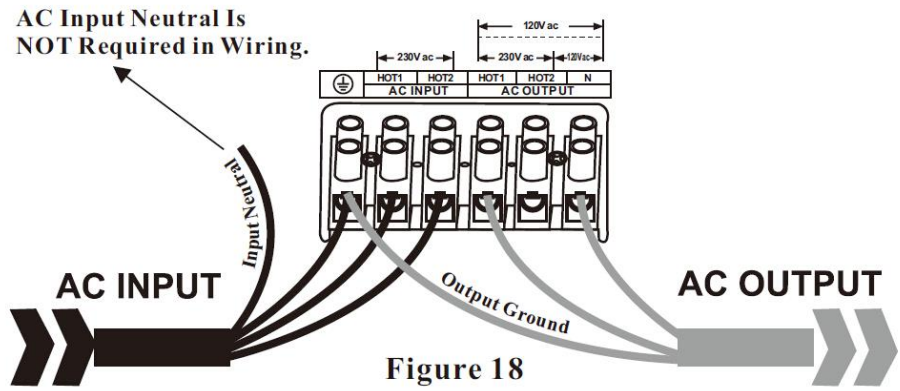
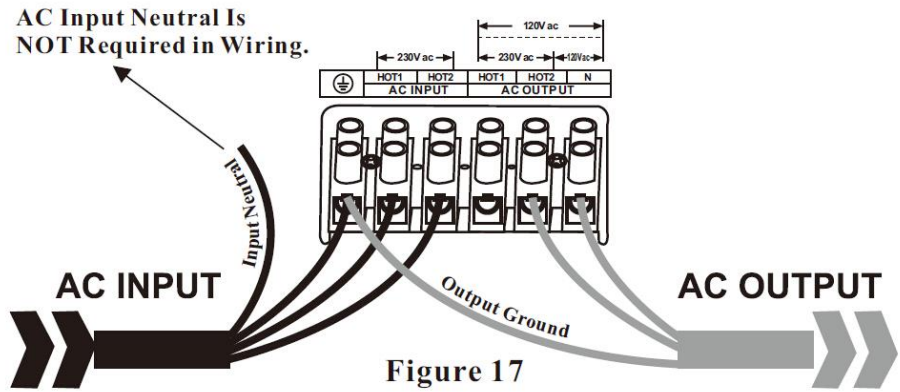

**Caution:**

**Wiring Option 2 and Wiring Option 3 are only allowed for 110/220V split phase models. Pls wire all the other models according to Wiring Option 1.**

|   |   |
|---|---|
|  <p><b>WARNING</b></p> | <p><b>For split phase models, AC input neutral is not required in wiring. Never Connect Input Neutral to Ground or to Output Neutral. Damage will result which is not covered under warranty.</b></p> <p><b>The output voltage of this unit must never be connected in its input AC terminal, overload or damage may result.</b></p> <p><b>Always switch on the inverter before plugging in any appliance.</b></p> <p><b>Damages caused by AC wiring mistakes are not covered under warranty.</b></p> |
|---|---|

**Preventing Paralleling of the AC Output**

The AC output of the unit should never be connected to the utility power / generator. Such a connection may result in parallel operation of the different power sources and AC power from the utility / generator will be fed back into the unit which will instantly damage the inverter and may also pose a fire and safety hazard.

**3.5 Grounding**

Connect an AWG 8 gauge or greater copper wire between the grounding terminal on the inverter and the earth grounding system or the vehicle chassis.

**3.6 Mounting the Inverter**

In order to mount the inverter securely, the surface and the mounting hardware must also be able to support

at least twice the weight of the inverter. To meet regulatory safety requirements, the Sigineer Power APC Series must be mounted:

- 1: On a horizontal surface (shelf or table top) with top side up,
- 2: On a vertical surface (like a wall) with the DC terminals facing left and the fan axis horizontal.
- 3: On a vertical surface (like a wall) with the DC terminals facing down and the fan axis vertical.



**Warning! Don't mount the inverter upside down.**

The inverter surface may get as high as 80°C (176°F) during operation, do not touch.

The unit should be installed so it is not likely to come into contact with people.

After determining the mounting position, refer to the physical dimensions as shown in below figures or use the base of the inverter as a template to mark your mounting screw locations. After marking the mounting screw locations, mount the unit with appropriate mounting hardware.

|   |                |
|---|----------------|
| <p style="text-align: center;"><b>Frame 2</b></p> | <p>1.5-4KW</p> |
| <p style="text-align: center;"><b>Frame 3</b></p> | <p>5-6KW</p>   |

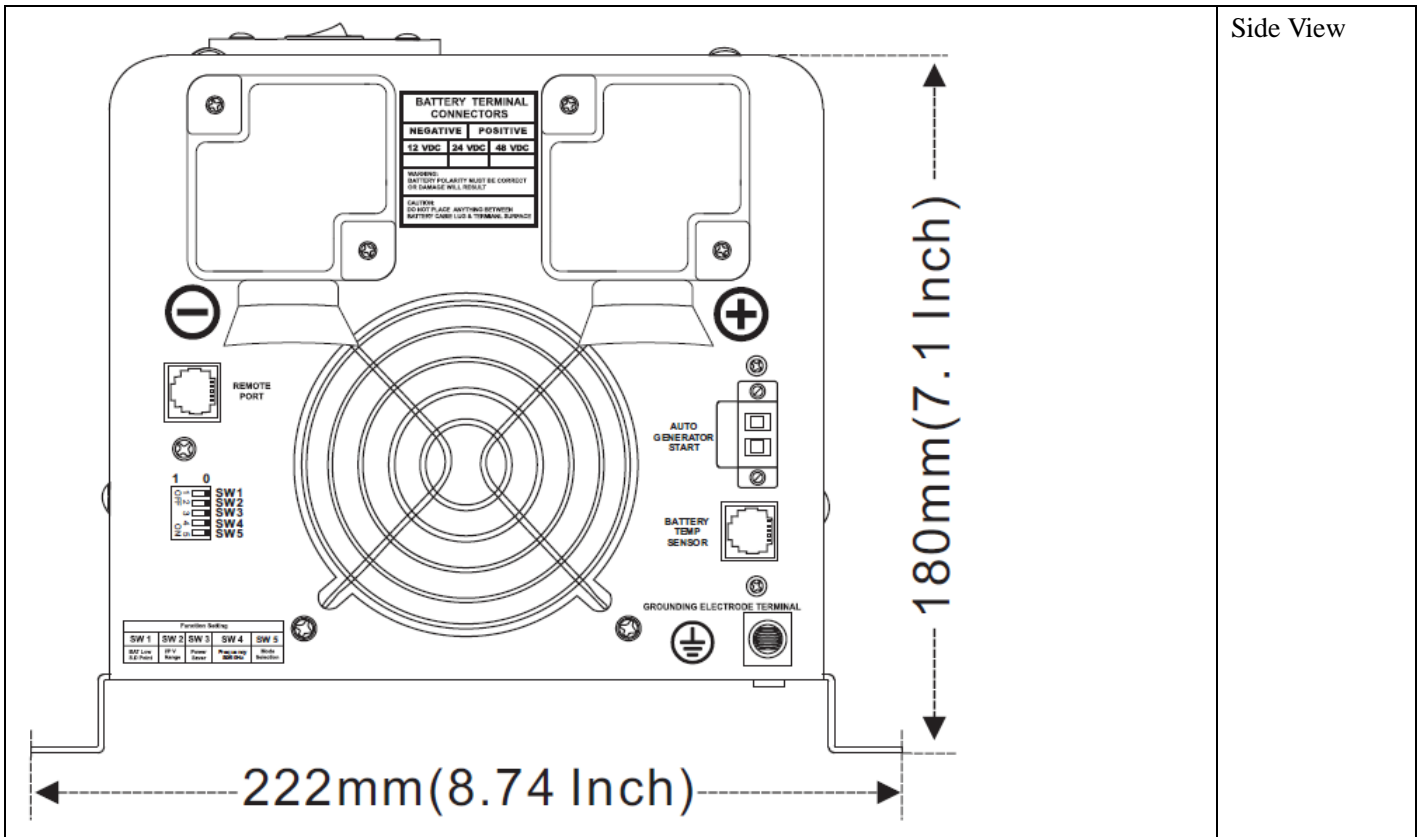

### 4 Troubleshooting Guide

Troubleshooting contains information about how to troubleshoot possible error conditions while using the APC Inverter & Charger.

The following chart is designed to help you quickly pinpoint the most common inverter failures.

#### Indicator and Buzzer

| Status        | Item                  | Indicator on top cover |             |          |           |                |                |                | LED on Remote Switch |          |       | Buzzer                   |
|---------------|-----------------------|------------------------|-------------|----------|-----------|----------------|----------------|----------------|----------------------|----------|-------|--------------------------|
|               |                       | SHORE POWER ON         | INVERTER ON | FAST CHG | FLOAT CHG | OVER TEMP TRIP | OVER LOAD TRIP | POWER SAVER ON | BATT CHG             | INVERTER | Alarm |                          |
| Line Mode     | CC                    | √                      | ×           | √        | ×         | ×              | ×              | ×              | √                    | ×        | ×     | ×                        |
|               | CV                    | √                      | ×           | √, blink | ×         | ×              | ×              | ×              | √                    | ×        | ×     | ×                        |
|               | Float                 | √                      | ×           | ×        | √         | ×              | ×              | ×              | √                    | ×        | ×     | ×                        |
|               | Standby               | √                      | ×           | ×        | ×         | ×              | ×              | ×              | ×                    | ×        | ×     | ×                        |
| Inverter Mode | Inverter On           | ×                      | √           | ×        | ×         | ×              | ×              | ×              | ×                    | √        | ×     | ×                        |
|               | Power Saver           | ×                      | ×           | ×        | ×         | ×              | ×              | √              | ×                    | ×        | ×     | ×                        |
| Inverter Mode | Low Battery           | ×                      | √           | ×        | ×         | ×              | ×              | ×              | ×                    | √        | √     | Beep 0.5s every 5s       |
|               | High Battery          | ×                      | √           | ×        | ×         | ×              | ×              | ×              | ×                    | √        | √     | Beep 0.5s every 1s       |
|               | Overload Invert Mode  | ×                      | √           | ×        | ×         | ×              | √              | ×              | ×                    | √        | √     | Refer to “Audible alarm” |
|               | Over-Temp Invert Mode | ×                      | √           | ×        | ×         | √              | ×              | ×              | ×                    | √        | √     | Beep 0.5s every 1s       |
|               | Over-Temp Line Mode   | √                      | ×           | √        | ×         | √              | ×              | ×              | √                    | ×        | √     | Beep 0.5s every 1s       |
|               | Over Charge           | √                      | ×           | √        | ×         | ×              | ×              | ×              | √                    | ×        | √     | Beep 0.5s every 1s       |

|                 |              |   |   |   |   |   |   |   |   |   |   |                 |                 |
|-----------------|--------------|---|---|---|---|---|---|---|---|---|---|-----------------|-----------------|
| Fault           | Fan Lock     | × | × | × | × | × | × | × | × | × | × | ×               | Beep continuous |
|                 | Battery High | × | √ | × | × | × | × | × | × | √ | × | ×               | Beep continuous |
|                 | Overload     | × | × | × | × | × | √ | × | × | × | × | ×               | Beep continuous |
|                 | Invert Mode  | × | × | × | × | × | √ | × | × | × | × | ×               | Beep continuous |
|                 | Output Short | × | × | × | × | × | √ | × | × | × | × | √               | Beep continuous |
|                 | Over-Temp    | × | × | × | × | √ | × | × | × | × | × | ×               | Beep continuous |
|                 | Over Charge  | × | × | √ | × | × | × | × | × | √ | × | ×               | Beep continuous |
| Back Feed Short | ×            | × | × | × | × | × | × | × | × | × | × | Beep continuous |                 |

| Symptom  | Possible Cause  | Recommended Solution   |
|--|---|--|
| Inverter will not turn on during initial power up.                                 | Batteries are not connected, loose battery-side connections.<br><br>Low battery voltage.                        | Check the batteries and cable connections. Check DC fuse and breaker.<br><br>Charge the battery.                             |
| No AC output voltage and no indicator lights ON.                                   | Inverter has been manually transitioned to OFF mode.  | Press the switch to Power saver on or Power saver off position.  |
| AC output voltage is low and the inverter turns loads OFF in a short time.         | Low battery.  | Check the condition of the batteries and recharge if possible.   |
| Charger is inoperative and unit will not accept AC.                                | AC voltage has dropped out-of-tolerance   | Check the AC voltage for proper voltage and frequency.   |
| Charger is supplying a lower charge rate.  | Charger controls are improperly set.<br><br>Low AC input voltage.<br><br>Loose battery or AC input connections. | Refer to the section on adjusting the “Charger Rate”.<br><br>Source qualified AC power.<br><br>Check all DC /AC connections. |
| Charger turns OFF while charging from a generator.                                 | High AC input voltages from the generator.  | Load the generator down with a heavy load.<br>Turn the generator output voltage down.  |
| Sensitive loads turn off temporarily when transferring between grid and inverting. | Inverter's Low voltage trip voltage may be too low to sustain certain loads.                                    | Choose narrow AC voltage in the DIP switch, or Install a UPS if possible.  |
| Noise from Transformer/case*   | Applying specific loads such as hair drier  | Remove the loads   |

**\*The reason for the noise from transformer and/or case**

When in inverter mode and the transformer and/or case of the inverter sometimes may vibrate and make noise.

If the noise comes from transformer.

According to the characteristics of our inverter, there is one type of load which will most likely to cause rattles of transformer.



That is a half-wave load, load that uses only a half cycle of the power(see figure 1). This trends to cause imbalance of magnetic field of transformer, reducing its rated working freq from 20KHz to, say, maybe 15KHz (it varies according to different loads). This way, the freq of noise falls exactly into the range (200Hz-20KHz) that human ear can sense.

The most common load of such kind is hair drier.

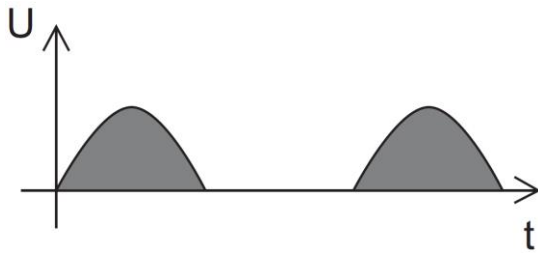

If the noise comes from case.

Normally when loaded with inductive loads, the magnetic field generated by transformer keeps attracting or releasing the steel case at a specific freq, this may also cause noise.

Reducing the load power or using an inverter with bigger capacity will normally solve this problem.

The noise willn't do any harm to the inverter or the loads.

## 5 Warranty

We warrant this product against defects in materials and workmanship for a period of one year from the date of purchase and will repair or replace any defective APC Inverter when directly returned, postage prepaid, to manufacturer. This warranty will be considered void if the unit has suffered any obvious physical damage or alteration either internally or externally and does not cover damage arising from improper use such as plugging the unit into an unsuitable power sources, attempting to operate products with excessive power consumption requirements, reverse polarity, or use in unsuitable climates.

**WARRANTY DOES NOT INCLUDE LABOR, TRAVEL CHARGES, OR ANY OTHER COSTS INCURRED FOR REPAIR, REMOVAL, INSTALLATION, SERVICING, DIAGNOSING OR HANDLING OF EITHER DEFECTIVE PARTS OR REPLACEMENT PARTS. THE WARRANTOR ASSUMES NO LIABILITY FOR INCIDENTAL OR CONSEQUENTIAL DAMAGES OF ANY KIND.**

**LOSS OR DAMAGE:** Loss or damage in transit is the responsibility of the carrier. Any claim should be filed with the delivering transport company. Invoice, Bill of Lading and Delivery receipt with damage noted therein must accompany any claims for freight damage. Claims for shortage and lost shipments must be made in writing to the shipper within 3 days of the receipt of shipment. Claims not reported within this time frame will not be honored.

This warranty does not apply to and we will not be responsible for any defect in or damage to:

- a) the product if it has been misused, neglected, improperly installed, physically damaged or altered, either internally or externally, or damaged from improper use or use in an unsuitable environment; violations of the warnings in the manual will invalid the warranty.
- b) the product if it has been subjected to fire, water, generalized corrosion, biological infestations, or input voltage that creates operating conditions beyond the maximum or minimum limits listed in the product specifications including high input voltage from generators and lightning strikes;
- c) the product if repairs have been done to it other than by our company or its authorized service centers;

# Appendix 1 Sigineer Power APC Series Inverter & Charger

| Electrical Specifications |                                    |  |       |       |       |           |        |        |  |
|---------------------------|------------------------------------|--|-------|-------|-------|-----------|--------|--------|--|
|                           | Model                              | 1KW  | 1.5KW | 2KW   | 3KW   | 4KW       | 5KW    | 6KW    |  |
| Inverter Output           | Continuous Output Power            | 1000W  | 1500W | 2000W | 3000W | 4000W     | 5000W  | 6000W  |  |
|                           | Surge Rating(20s)                  | 3000W  | 4500W | 6000W | 9000W | 12000W    | 15000W | 18000W |  |
|                           | Capable of Starting Electric Motor | 1HP  | 1.5HP | 2HP   | 3HP   | 4HP       | 5HP    | 6HP    |  |
|                           | Output Waveform                    | Pure Sine wave/Same as input(Bypass mode)  |       |       |       |           |        |        |  |
|                           | Peak Efficiency                    | 88%  |       |       |       |           |        |        |  |
|                           | Line Mode Efficiency               | >95%   |       |       |       |           |        |        |  |
|                           | Power Factor                       | 0.9-1.0  |       |       |       |           |        |        |  |
|                           | Nominal Output Voltage rms         | 100-110-120Vac / 220-230-240Vac  |       |       |       |           |        |        |  |
|                           | Output Voltage Regulation          | ±10% RMS   |       |       |       |           |        |        |  |
|                           | Output Frequency                   | 50/60Hz ±0.3Hz   |       |       |       |           |        |        |  |
|                           | Short Circuit Protection           | Yes, Current Limit Function (Fault after 1sec)   |       |       |       |           |        |        |  |
|                           | Typical transfer Time              | 10ms(Max)  |       |       |       |           |        |        |  |
|                           | THD                                | < 10%  |       |       |       |           |        |        |  |
| DC Input                  | Nominal Input Voltage              | 12.0Vdc<br>( *2 for 24Vdc, *4 for 48Vdc)   |       |       |       |           |        |        |  |
|                           | Minimum Start Voltage              | 10.0Vdc  |       |       |       |           |        |        |  |
|                           | Low Battery Alarm                  | 10.5Vdc / 11.0Vdc  |       |       |       |           |        |        |  |
|                           | Low Battery Trip                   | 10.0Vdc / 10.5Vdc  |       |       |       |           |        |        |  |
|                           | High Voltage Alarm & Fault         | 16.0Vdc  |       |       |       |           |        |        |  |
|                           | High DC Input Recovery             | 15.5Vdc  |       |       |       |           |        |        |  |
|                           | Low Battery voltage recover        | 13.0Vdc  |       |       |       |           |        |        |  |
|                           | Sleep Mode Threshold               | > 25 W when Power Saver On   |       |       |       |           |        |        |  |
| Charge                    | Input Voltage Range                | Narrow: 100~135VAC / 194~243VAC;<br>Wide: 90~135VAC / 164~243VAC;                      |       |       |       |           |        |        |  |
|                           | Input Frequency Range              | Narrow: 47-55±0.3Hz for 50Hz, 57-65±0.3Hz for 60Hz<br>Wide:43±0.3Hz plus for 50Hz/60Hz |       |       |       |           |        |        |  |
|                           | Output Voltage                     | Depends on battery type  |       |       |       |           |        |        |  |
|                           | Charger Breaker Rating(230Vac)     | 10A  | 10A   | 10A   | 20A   | 20A       | 30A    | 30A    |  |
|                           | Charger Breaker Rating(120Vac)     | 10A  | 20A   | 20A   | 30A   | 40A       | N/A    | N/A    |  |
|                           | Max Charge Rate                    | See specific charge rates in "AC Charger" section                                      |       |       |       |           |        |        |  |
|                           | Over Charge Protection Shutdown    | 15.7V for 12Vdc ( *2 for 24Vdc, *4 for 48Vdc)  |       |       |       |           |        |        |  |
|                           | Battery type                       | Fast Vdc   |       |       |       | Float Vdc |        |        |  |
|                           | Gel U.S.A                          | 14   |       |       |       | 13.7      |        |        |  |
|                           | A.G.M 1                            | 14.1   |       |       |       | 13.4      |        |        |  |
|                           | A.G.M 2                            | 14.6   |       |       |       | 13.7      |        |        |  |
|                           | Sealed Lead Acid                   | 14.4   |       |       |       | 13.6      |        |        |  |
|                           | Gel Euro                           | 14.4   |       |       |       | 13.8      |        |        |  |
|                           | Open Lead Acid                     | 14.8   |       |       |       | 13.3      |        |        |  |
| Calcium                   | 15.1                               |  |       |       | 13.6  |           |        |        |  |

|                                 |  |  |           |               |                     |                   |            |           |
|---------------------------------|--|--|-----------|---------------|---------------------|-------------------|------------|-----------|
|                                 | De-sulphation  | 15.5 for 4hrs  |           |               |                     |                   |            |           |
|                                 | Remote Control   | Yes. Optional  |           |               |                     |                   |            |           |
| Bypass & Protection             | Input Voltage Waveform                                     | Sine wave (Grid or Generator)                              |           |               |                     |                   |            |           |
|                                 | Nominal Voltage  | 120Vac   |           |               | 230Vac              |                   |            |           |
|                                 | Low Voltage Trip   | 80V/90V $\pm 4\%$  |           |               | 184V/154V $\pm 4\%$ |                   |            |           |
|                                 | Low Voltage re engage                                      | 90V/100V $\pm 4\%$   |           |               | 194V/164V $\pm 4\%$ |                   |            |           |
|                                 | High Voltage Trip  | 140V $\pm 4\%$   |           |               | 253V $\pm 4\%$      |                   |            |           |
|                                 | High Voltage re engage                                     | 135V $\pm 4\%$   |           |               | 243V $\pm 4\%$      |                   |            |           |
|                                 | Max Input AC Voltage                                       | 150VAC   |           |               | 270VAC              |                   |            |           |
|                                 | Nominal Input Frequency                                    | 50Hz or 60Hz (Auto detect)                                 |           |               |                     |                   |            |           |
|                                 | Low Freq Trip  | Narrow: 47 $\pm 0.3$ Hz for 50Hz, 57 $\pm 0.3$ Hz for 60Hz |           |               |                     |                   |            |           |
|                                 |  | Wide: 40 $\pm 0.3$ Hz for 50Hz/60Hz                        |           |               |                     |                   |            |           |
|                                 | Low Freq re engage   | Narrow: 48 $\pm 0.3$ Hz for 50Hz, 58 $\pm 0.3$ Hz for 60Hz |           |               |                     |                   |            |           |
|                                 |  | Wide: 45 $\pm 0.3$ Hz for 50Hz/60Hz                        |           |               |                     |                   |            |           |
|                                 | High Freq Trip   | Narrow: 55 $\pm 0.3$ Hz for 50Hz, 65 $\pm 0.3$ Hz for 60Hz |           |               |                     |                   |            |           |
|                                 |  | Wide: No up limit for 50Hz/60Hz                            |           |               |                     |                   |            |           |
| High Freq re engage             | Narrow: 54 $\pm 0.3$ Hz for 50Hz, 64 $\pm 0.3$ Hz for 60Hz |  |           |               |                     |                   |            |           |
|                                 | Wide: No up limit for 50Hz/60Hz                            |  |           |               |                     |                   |            |           |
| Output Short circuit protection | Circuit breaker  |  |           |               |                     |                   |            |           |
| Bypass breaker rating (230Vac)  | 10A  | 15A  | 20A       | 30A           | 30A                 | 40A               | 40A        |           |
| Bypass breaker rating (120Vac)  | 20A  | 20A  | 30A       | 40A           | 50A                 | N/A               | N/A        |           |
| Mechanical Specification        | Mounting   | Wall/Ground mount  |           |               |                     |                   |            |           |
|                                 | Inverter Dimensions(L*W*H)                                 | 442*218*179mm  |           | 442*218*179mm |                     | 598*218*179mm     |            |           |
|                                 |  | 17.5*8.5*7"  |           | 17.5*8.5*7"   |                     | 23.5*8.5*7"       |            |           |
|                                 | Inverter Weight  | 16KG   | 17KG      | 20KG          | 24KG                | 35KG              | 44KG       | 45KG      |
|                                 |  | 35.27lbs   | 37.48 lbs | 44.1 lbs      | 52.91 lbs           | 77.16 lbs         | 97 lbs     | 99.21 lbs |
|                                 | Shipping Dimensions(L*W*H)                                 | 595*330*320mm  |           | 595*330*320mm |                     | 800*360*350mm     |            |           |
|                                 |  | 23.5*13*12.5"  |           | 23.5*13*12.5" |                     | 30.5*14.25*13.75" |            |           |
|                                 | Shipping Weight  | 18KG   | 19KG      | 22KG          | 26KG                | 37KG              | 46KG       | 47KG      |
| 39.68 lbs                       |  | 41.89 lbs  | 48.51 lbs | 57.32 lbs     | 81.57 lbs           | 101.41 lbs        | 103.61 lbs |           |
| Display                         | Status LEDs  |  |           |               |                     |                   |            |           |
| Standard Warranty               | 1 Year   |  |           |               |                     |                   |            |           |

※Specifications in this manual are subject to change without prior notice.



# Sigineer Power

Shenzhen Sigineer Power CO.,LTD.

Email: [info@sigineer.com](mailto:info@sigineer.com)

TEL: +86 755 2160 7078

FAX: +86 755 6165 8278

Add: Bld A, Jiali Industrial Zone, Yuanfen Rd, Longhua, Shenzhen, 518100, China

## **SAVE THIS MANUAL!**

**READ THIS MANUAL BEFORE INSTALLATION, IT  
CONTAINS IMPORTANT SAFETY, INSTALLATION AND  
OPERATING INSTRUCTIONS. KEEP IT IN A SAFE PLACE  
FOR FUTURE REFERENCE.**

**WE WISH YOU A PLEASANT EXPERIENCE IN USING OUR  
INVERTERS.**

(PN: 614-01666-04 / UPDATED IN JAN 2015)