

KÄRCHER

makes a difference

BR 35/12 C Bp

English	3
Français	18
Español	35

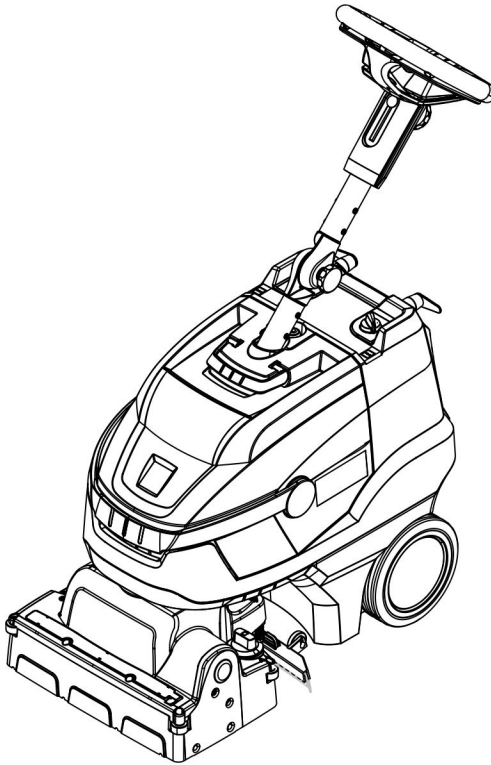

**Register
your product**
www.kaercher.com/welcome



59653510 05/21

IMPORTANT SAFETY INSTRUCTIONS

READ ALL INSTRUCTIONS BEFORE USING.

WARNING

To reduce the risk of fire, electric shock, or injury:

- DO NOT LEAVE appliance unattended when plugged in. Unplug from outlet when not in use and before servicing.

WARNING

- TO REDUCE THE RISK OF ELECTRIC SHOCK-USE INDOORS ONLY
- Do not allow to be used as a toy. Close attention is necessary when used near children.
- Use only as described in this manual. Use only manufacturer's recommended attachments.
- Do not use with damaged cord or plug. If appliance is not working as it should, has been dropped, damaged, left outdoors, or dropped into water, return it to a service center.
- Do not pull or carry by cord, use cord as a handle, close a door on cord, or pull cord around sharp edges or corners. Do not run the unit over cord. Keep cord away from heated surfaces.
- Do not unplug by pulling on cord. To unplug, grasp the plug, not the cord.
- Do not handle plug or appliance with wet hands.
- Do not put any object into openings. Do not use with any opening blocked; keep free of dust, lint, hair,

and anything that may reduce air flow.

- Keep hair, loose clothing, fingers, and all parts of body away from openings and moving parts.
- Turn off all controls before unplugging.
- Use extra care when cleaning on stairs.
- Do not use to pick up flammable or combustible liquids, such as gasoline, or use in areas where they may be present.
- Connect to a properly grounded outlet only. See Grounding Instructions.

SAVE THESE INSTRUCTIONS

GROUNDING INSTRUCTIONS

This appliance must be grounded. If it should malfunction or break down, grounding provides a path of least resistance for electric current to reduce the risk of electric shock.

The plug must be inserted into an appropriate outlet that is properly installed and grounded in accordance with all local codes and ordinances.

WARNING

Improper connection of the equipment-grounding conductor can result in a risk of electric shock.

Check with a qualified electrician or service person if you are in doubt as to whether the outlet is properly grounded.

Do not modify the plug provided with the appliance.

If it will not fit the outlet, have a proper outlet installed by a qualified electrician.

This appliance is for use on a nominal 120-volt circuit and has a grounding attachment plug that looks like the plug illustrated in sketchpicture A. Make sure that the appliance is connected to an outlet having the same configuration as the plug. No adaptor should be used with this appliance.

CONNECT TO A PROPERLY GROUNDED OUTLET ONLY

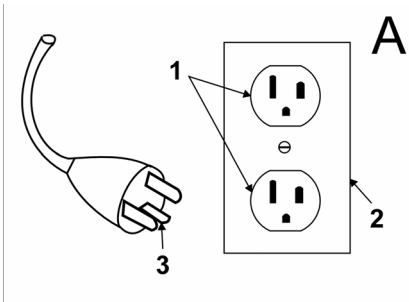

- 1 Grounded outlet
- 2 Grounded outlet box
- 3 Grounded pin

OPERATING SAFETY RULES AND PRACTICES

Operator Responsibility

Safe operation is in the responsibility of the operator.

The operator shall be familiar with the operation and function of all controls and instruments before undertaking to operate the unit.

Before operating the unit, operators shall have read and be familiar with the operator's manual for the particular unit being operated and they shall also abide by the safety rules and practices in the following paragraphs.

Before operating any unit, the operator shall be familiar with unusual operating conditions which may require additional safety precautions or special operating instructions.

General

Before starting to operate the unit be in operating position.

Do not start or operate the unit, any of its functions or attachments, from any place other than from the designated operators position.

Before leaving the operator's position:

- A bring the unit to a complete stop;
- B if the unit must be on an incline, block the wheels.

Maintain a safe distance from the edge of ramps, platforms, and other similar working surfaces.

Do not add to, or modify the unit.

Do not block access to fire aisles, stairways or fire equipment.

Travelling

Yield the right of way to pedestrians and emergency vehicles such as ambulances and fire trucks.

Cross railroad tracks at an angle whenever possible. Do not park closer than 6 ft (1800 mm) to the nearest rail of a railroad track.

Keep a clear view of the path of travel and observe for other traffic, personnel, and safe clearances.

Under all travel conditions, operate the unit at a speed that will permit it to be brought to a stop in a safe manner.

Do not indulge in stunt driving or horseplay.

Slow down for wet and slippery floors.

Before driving over a dockboard or bridge plate, be sure that it is properly secured. Drive carefully and slowly across the dockboard or bridge plate, and never exceed its rated capacity.

When negotiating turns, reduce speed to a safe level consistent with the operating environment. Make the turns smoothly.

Operator care of the unit

If the unit is found to be in need of repair or in any way unsafe, or contributes to an unsafe condition, the matter shall be reported immediately to the user's designated authority, and the unit shall not be operated until it has been restored to safe operating condition.

If during operation the unit becomes unsafe in any way, the matter shall be reported immediately to the user's designated authority, and the unit shall not be operated until it has been restored to safe operating condition.

Do not make repairs or adjustments unless specifically authorized to do so.

MAINTENANCE AND RE-BUILD PRACTICES

Operation of the unit may be hazardous if maintenance is neglected or repairs, rebuilds, or adjustments are not performed in accordance with the manufacturer's design criteria. Therefore, maintenance facilities (on or off premises), trained personnel, and detailed procedures shall be provided.

Maintenance and inspection of the unit shall be performed in conformance with the following practices:

- A a schedules planned maintenance, lubrication, and inspection system shall be followed; consult the manufacturer's recommendations.
- B only trained and authorized personnel shall be permitted to maintain, repair, adjust, and inspect the unit, and in accordance with manufacturer's specifications.

Avoid fire hazards and have fire protection equipment present in the work area. Do not use open pans of fuel or

flammable cleaning fluids for cleaning parts.

FIRE SAFETY STANDARD

Any unit not in safe operating condition shall be removed from service.

Repairs shall not be made in Class I, Class II, and Class III locations.

Fire Prevention: The unit shall be kept in a clean condition and reasonably free of lint, excess oil, and grease.

Noncombustible agents are preferred for cleaning the unit. Flammable liquids [those having flash points at or above 100°F (37,8°C)] are not allowed. Precautions regarding toxicity, ventilation, and fire hazard shall be appropriate for the agent or solvent used.

Nameplate Visibility: The unit type designations as shown on the nameplate and the type markers shall not be covered over with paint so that their identification information is obscured.

The unit shall not be used in classified areas.



Please read and comply with these original instructions prior to the initial operation of your appliance and store them for later use or subsequent owners.

Contents

Safety instructions	EN . . . 4
Function	EN . . . 5
Proper use	EN . . . 5
Environmental protection	EN . . . 5
Operating elements	EN . . . 6
Before Startup	EN . . . 7
Operation	EN . . . 7
Transport	EN . . 10
Storage	EN . . 10
Care and maintenance	EN . . 10
Disposal	EN . . 11
Faults	EN . . 12
Accessories	EN . . 13
Technical specifications	EN . . 14
Warranty	EN . . 15
Spare parts	EN . . 15

Safety instructions

Before using the appliance for the first time, read and observe these operating instructions and the accompanying brochure: Safety information for brush cleaning units, 5.956-251.0.

⚠ WARNING

Do not use the appliance on inclines.
The appliance may only be operated when the container and all lids are closed.

Symbols in the operating instructions

⚠ DANGER

Immediate danger that can cause severe injury or even death.

⚠ WARNING

Possible hazardous situation that could lead to severe injury or even death.

CAUTION

Possible hazardous situation that could lead to mild injury to persons or damage to property.

Information on battery (accumulator) and charger

Lithium-ion batteries are installed in the appliance. These are subject to special criteria. The removal and the installation as well as the examination of defective batteries may only be performed by the Kärcher aftersales service or a specialist.

Information on storage and transport can be obtained from your Kärcher aftersales service.

⚠ DANGER

- *Alterations and modifications on the appliance are prohibited.*
- **Do not open the battery**, as there is a risk of an electrical shock; also, irritating or caustic vapors can escape.
- **Do not expose the battery to direct sunlight, heat or fire**, there is a risk of explosion.
- *Do not operate the charger in explosive environment.*
- *Ensure sufficient ventilation during the charging process.*
- *Do not use the charger if dirty or wet.*

- Do not work with open flames, generate sparks or smoke in the vicinity of a battery or a battery charging room. Danger of explosion.

⚠ WARNING

- Check the appliance and the power cable for damage prior to every use. Do not use damaged appliances and have damaged parts repaired by specialists only.
- Keep children away from batteries and charger.
- Do not charge damaged batteries. Have damaged batteries replaced by the Kärcher aftersales service.
- Do not discard defective batteries in the domestic waste, inform Kärcher aftersales service.
- Avoid contact with liquids oozing out of defective battery packs. Rinse thoroughly if you accidentally come in contact with the fluid. Also consult a doctor if the fluid comes in contact with your eyes.

CAUTION

- These operating instructions must be observed unconditionally. Observe recommendations of the law-maker for handling batteries.
- The mains voltage must correspond with the voltage indicated on the type plate of the appliance.
- Use the charger only to charge approved battery packs.
- The accumulator may only be operated with this appliance. It is dangerous and prohibited to use it for other purposes.

Safety installations

If the safety switch is released, the brush drive shuts off.

Function

The scrubbing vacuum cleaner is used for the wet cleaning of level floors.

It can be easily adjusted to the cleaning task by setting the water quantity. A working width of 350 mm and a capacity of 12 l in the fresh and wastewater tank each enable effective cleaning with long action times.

The battery can be charged on a 110 V power outlet by means of the integrated charger.

Proper use

Use this appliance only as directed in these operating instructions.

- The appliance should only be used for cleaning level floors that are not affected by moisture.
- This appliance is intended for inside use.
- The appliance is not suited for the cleaning of frozen grounds (e.g. in cold stores).
- The appliance may only be equipped with original accessories and spare parts.

Environmental protection



The packaging material can be recycled. Please do not place the packaging into the ordinary refuse for disposal, but arrange for the proper recycling.



Old appliances contain valuable materials that can be recycled.

Please arrange for the proper recycling of old appliances. Please dispose your old appliances using appropriate collection systems.

Notes about the ingredients (REACH)

You will find current information about the ingredients at:

www.kaercher.com/REACH

Operating elements

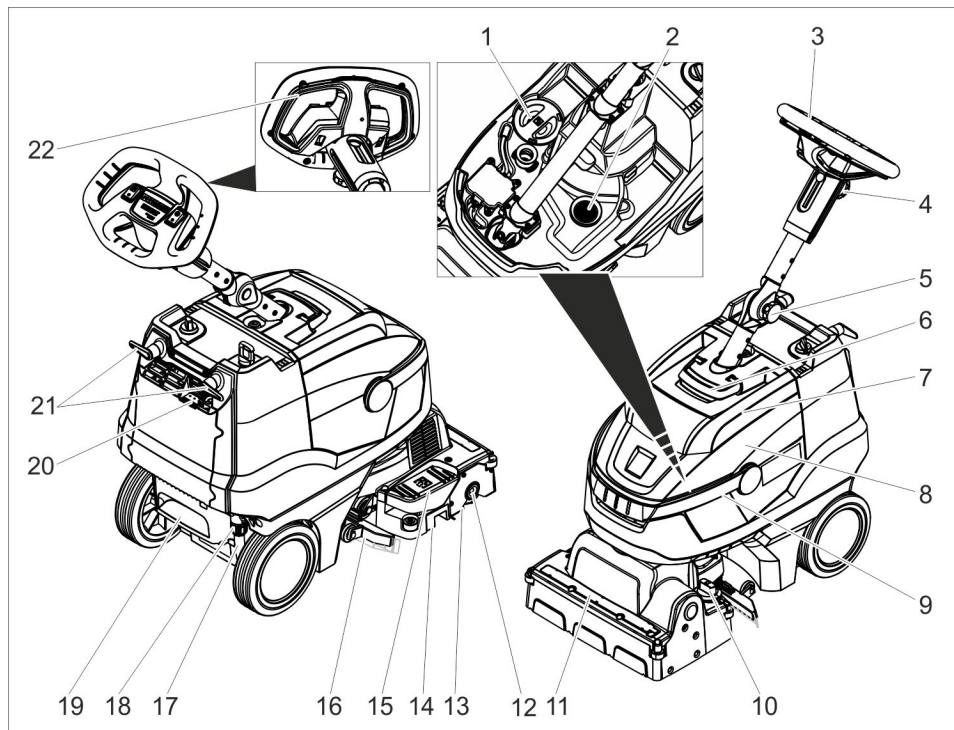

- | | |
|---|--|
| 1 Fresh water tank cover | 13 Brush roller |
| 2 Fluff filter | 14 Coarse dirt container |
| 3 Steering wheel | 15 Vacuum bar lift pedal |
| 4 Star knob, height adjustment of the steering wheel | 16 Vacuum bar |
| 5 Star knob, transport position of the steering wheel | 17 Fresh water level display |
| 6 Unlocking device, cover waste water tank | 18 Coupling for draining the fresh water |
| 7 Cover dirt water reservoir | 19 Step depression |
| 8 waste water tank | 20 Battery charging display |
| 9 Carrying handle for waste water tank | 21 Cable hook, rotating |
| 10 Rotating handle for brush contact pressure
(1=min, 4=max) | 22 Safety button |
| 11 Water distribution bar | |
| 12 Unlocking button for brush roller | |

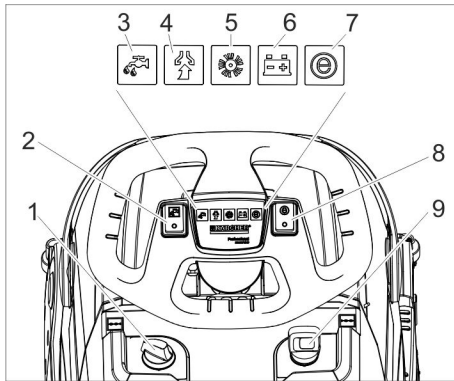

- 1 Dosage cleaning solution
- 2 Switch for detergent solution
- 3 Control lamp to apply detergent solution
- 4 Indicator lamp vacuuming
Green: Suction turbine in operation
Orange, flashing: Suction turbine overloaded
- 5 Indicator lamp brush drive
Green: Brush is rotating
Orange, flashing: Brush overloaded
- 6 Battery status display
Green Battery charged
Orange: Battery almost empty
Red Appliance switches off: Load battery
- 7 Indicator lamp Eco mode
- 8 Switch Eco mode
- 9 Power switch

Before Startup

Charging battery

NOTICE

The device is equipped with a safety mechanism to prevent total discharge, i.e. when the permissible minimum capacity is reached, the machine will be shut off.

The charging process takes approx. 3 hours.

The charger automatically switches off the charging process.

If necessary, the appliance can be used again before the battery has been fully charged.

→ Insert the mains plug into the socket.

Battery charging display

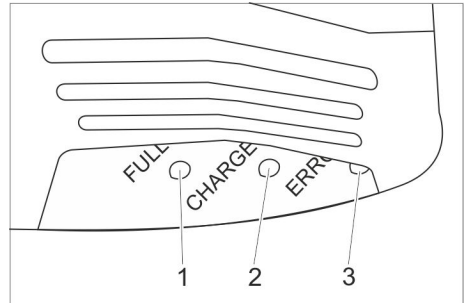

- 1 Battery is charged (green)
- 2 Battery is being charged (yellow, flashing)
- 3 Malfunction (red)

Operation

- Release the star knob for the transport position.
- Straighten the steering column.
- Tighten the star handle.

Filling in detergents

⚠ Warning

Risk of damage. Only use the recommended detergents. With respect to different detergents the operator bears the increased risk regarding the operational safety and danger of accident.

Only use detergents that are free from solvents, hydrochloric acid and hydro-fluoric acid.

Follow the safety instructions for using detergents.

Note

Do not use highly foaming detergents. Observe the dosing notes.

- Swivel up the carrying handle of the waste water tank.

- Lift out the waste water tank and put it aside.
- Remove the lid from the fresh water reservoir.
- Fill in fresh water (maximum 50 °C).
- Add detergent. Follow dosing instructions for detergent.

Recommended detergents:

Application	Detergent
Regular cleaning (even for floors sensitive to alkalis)	RM 745 RM 746
Cleaning dirt from grease	RM 69 ES ASF RM 69 ASF
Basic cleaning (stripping) of alkali-resistant hard coatings	RM 752
Basic cleaning (stripping) linoleum	RM 754
Base cleaner, acidic	RM 751
Disinfection cleaning	RM 732

Detergents are available in specialised stores.

- Close the cover of the fresh water reservoir.
- Place the waste water tank on the appliance.

Settings

- Release the star knob for the height adjustment of the steering wheel.
- Adjust the steering wheel to the desired height.
- Tighten the star handle.
- Adjust the dosing of the cleaning solution in accordance with the soiling and the type of the flooring material.
- Adjust the rotary handle of the brush contact pressure to the desired value.

Only adjust the brush contact pressure when the cleaning head is raised.

Note:

If the appliance pulls forwards too strongly during operation, reduce the contact pressure.

- Bring the Eco mode switch into the desired position.

Normal operation: The appliance works at the maximum brush speed and the highest suction performance.

Eco: The appliance works at reduced brush speed and suction performance. This also reduces the energy consumption. The possible action time with one charging cycle increases.

Cleaning

CAUTION

Risk of damage to the floor covering. Do not operate the appliance on the spot.

Risk of damage. Lift the vacuum bar before pulling the appliance backwards over a longer distance.

- Set the appliance switch to "I".
- Switch on "Detergent" button.
- Press the switch of the suction turbine; the vacuum process will start.
- Push down the pedal of the vacuum bar lifting device at the back to lower the vacuum bar.
- Pull the safety switch towards the steering wheel, the brush drive and the application of the cleaning solution are switched on (if preset).
- Push the appliance forward until the parking stand folds up and the cleaning head touches the ground.
- Move the appliance over the surface to be cleaned.

Note:

If the steering wheel is turned by 180°, the appliance also reverses.

Shutting Down the Appliance

- Release the safety switch.
- Drive the appliance forward for another 1-2 m to draw off residual water.
- Push down the pedal of the vacuum bar lifting device at the front to raise the vacuum bar.

CAUTION

Vacuum lips and brush can be deformed permanently. Always park the appliance with the parking stand folded out.

- Set the appliance switch to "0".
- Place one foot in the tread and lift the front of the appliance by pulling on the steering wheel until the parking stand folds out.

Emptying the waste Water tank

⚠ Warning

Please observe the local provisions regarding the wastewater treatment.

- Swivel the handle of the waste water tank up and let it snap into place.
- Remove the waste water tank.

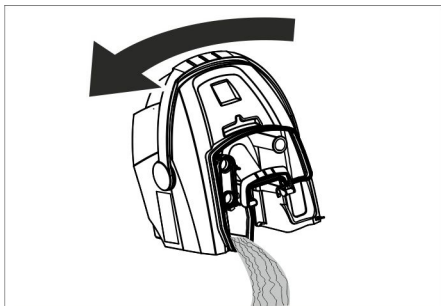

- Remove the cover of the waste water tank.
- Empty the waste water tank. Swivel the waste water tank sideways during emptying so that the tank is completely drained.

- Rinse the dirt water reservoir with clear water.
- Reattach the waste water tank to the appliance.

Emptying the Fresh Water Tank

⚠ Warning

Please observe the local provisions regarding the wastewater treatment.

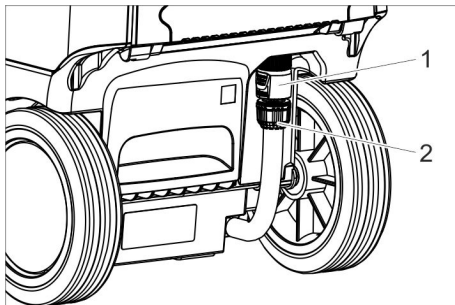

- 1 Coupling for draining the fresh water
- 2 Fresh water level display

- Slide the coupling down.
- Remove the hose of the level indicator and swivel it downwards.

Frost protection

In case of danger of frost:

- Empty the fresh and dirt water reservoirs.
- Store the appliance in a frost-protected room.

Folding down the steering column

To reduce the space requirements for transport and storage, the steering column can be folded down.

- Release the star knob for the transport position.
- Swivel the steering wheel forwards.
- Tighten the star handle.

Transport

CAUTION

Risk of injury and damage! Observe the weight of the appliance when you transport it.

- Remove the brush to avoid damage to the brushes.
- When transporting in vehicles, secure the appliance according to the guidelines from slipping and tipping over.

Shutting down

- Completely charge the battery prior to longer operational breaks extending over several weeks.
- Set the appliance switch to "0".

CAUTION

Risk of damage to the battery due to total discharge.

Always switch the power switch to "0" during operational breaks.

Storage

CAUTION

Risk of injury and damage! Note the weight of the appliance in case of storage. This appliance must only be stored in interior rooms.

Care and maintenance

⚠ DANGER

Risk of injury. Turn the appliance switch to "0" and pull the mains plug of the charger prior to performing any work on the appliance.

CAUTION

Risk of damage for the appliance due to leaking water. Drain the wastewater and remaining fresh water prior to performing tasks on the appliance.

- Park the machine on an even surface.

Maintenance schedule

After the work

⚠ Warning

Risk of damage. Do not wash down the appliance with water and do not use aggressive detergents.

- Drain off dirt water.
- Remove the lid of the waste water tank and wash the inside of the lid and the float with water.
- Rinse the waste water tank with clear water.
- Clean the vacuum bar.
- Remove bulk waste container and empty it.
- Clean the outside of the appliance with a damp cloth which has been soaked in mild detergent.
- Clean the vacuum lips, check for wear and replace them if required.
- Clean brush.
- Check the brush for wear and replace if required (see "Maintenance tasks").
- Charge battery if required.

Weekly

- Remove the water distribution bar on the cleaning head and clean the water channel.

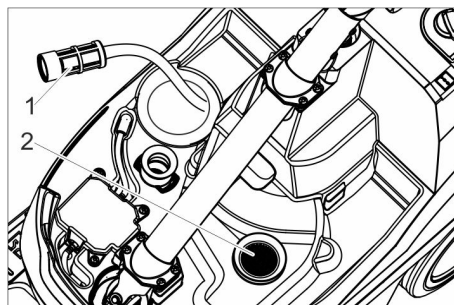

- 1 Fresh water filter
- 2 Fluff filter

- Clean the fresh water filter.
- Clean the fluff filter.

Monthly

- Check the condition of the seals between waste water tank and cover, replace if required.

Yearly

- Have the prescribed inspection carried out by the customer service.

Maintenance Works

Replacing the suction lips

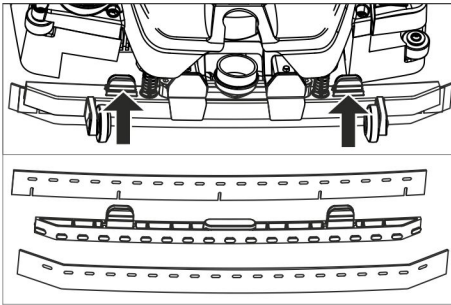

- Compress the fastening devices and pull the vacuum lips out of the vacuum bar towards the bottom.
- Remove the vacuum lips from the holder.

Note:

Thanks to the perforation pattern the vacuum lips cannot be mixed up. They cannot be turned and reinstalled.

- Replace vacuum lips.
- Insert the holder with the vacuum lips into the vacuum bar and snap into place.

Replacing the brush roller

⚠ WARNING

Risk of crushing due to the parking stand folding up during the brush replacement. Turn the steering wheel by 90° to the left prior to the brush replacement.

- Press the release button for the brush roller and swivel the brush

roller toward the bottom and pull it off the driver.

- Place the new brush roller on the driver and lock into place on the opposite side.

Maintenance contract

To ensure a reliable operation of the appliance maintenance contracts can be concluded with the competent Kärcher sales office.

Disposal

Removing the battery

⚠ DANGER

The removal of the battery may only be performed by the Kärcher aftersales service or a specialist.

The evaluation, whether the battery is damaged or not, is done by an authorised aftersales technician

The Chapter "Safety instructions" for handling accumulators must be observed unconditionally.

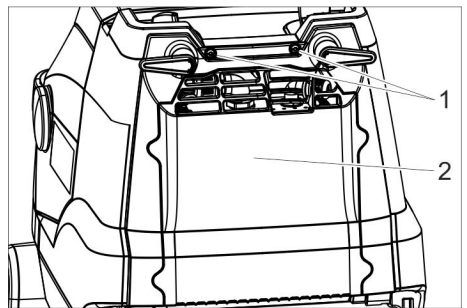

- 1 Screw
- 2 Cover

- Unscrew 2 screws.
- Swivel the lid downwards.
- Loosen and remove the battery plug.
- Remove the battery.
- Dispose of used battery in accordance with the applicable provisions.

Faults

⚠ DANGER

Risk of injury. Turn the appliance switch to "0" and pull the mains plug of the charger prior to performing any work on the appliance.

⚠ Warning

Risk of damage to the appliance on account of water leakage. Drain out dirty water and the remaining free water before working at the machine.

In case of faults that cannot be remedied using the table below please contact the customer service.

Fault	Remedy
Appliance cannot be started	Switch on the appliance switch, wait 3 seconds, check charge condition of the battery.
Insufficient water quantity	Check fresh water level, refill tank if necessary.
	Switch on "Detergent" button.
	Open the dosing device for the cleaning solution.
	Clean the fresh water filter.
Insufficient vacuum performance	Lower the vacuum bar.
	Empty the waste water tank.
	Clean the seals between waste water tank and cover and check for tightness, replace if required.
	Clean the vacuum lips on the vacuum bar, turn or replace if required
	Check if the suction hose and vacuum bar are chocked, clean if required
Insufficient cleaning result	Check the suction hose for tightness; replace if required.
	Check/set the brush contact pressure.
	Check the brush type and the detergent for their suitability.
Brush does not turn	Check the brushes for wear, replace if required.
	Pull the safety switch towards the steering wheel.
	Check if foreign matters are blocking the brush roller; remove foreign matter if required. Switch off the switch for the brush drive, wait for a short period of time, switch the switch back on.

Accessories

The appliance can be equipped with various accessories depending on the cleaning task. Please request our cata-

logue or visit us on the Internet at www.kaercher.com.

Description	Part no.:	Description
Brush roller, white (soft)	4.037-036.0	For polishing floors.
Brush roller, red (medium, standard)	4.037-031.0	For cleaning slightly dirtied or sensitive floors.
Brush roller, green (hard)	4.037-038.0	For cleaning heavily dirtied floors.
Brush roller, black (very hard)	4.037-039.0	For cleaning heavily dirtied floors.
Brush roller, orange (high/ low)	4.037-037.0	For scrubbing structured floors (safety tiles, etc.).
Microfibre roller	4.037-040.0	Cleaning brush made of microfibres with especially high cleaning performance, especially for fine stone tiles.
Pad roller shaft	4.762-009.0	For intake of roller pads.
Roller pad, red (medium)	6.369-047.0	For cleaning slightly dirtied floors.
Roller pad, green (hard)	6.369-052.0	For cleaning normal to heavily dirtied floors.
Roller pad, yellow (soft)	6.369-053.0	For polishing floors.
Fill hose	6.680-124.0	For filling the fresh water tank
Suction lip kit	4.037-035.0	As replacement

Technical specifications

Power		
Nominal voltage	V	25,9
Battery capacity	Ah (5h)	22
Battery type		Li-ion
Average power consumption	W	500
Protective class	-	1
Suction engine output	W	280
Brush engine output	W	185
Operating temperature range	°C	0...40
Vacuuming		
Cleaning power, air quantity	l/s	20
Cleaning power, negative pressure	kPa	8
Cleaning brushes		
Working width	mm	350
Brush diameter	mm	96
Brush speed	1/min	1050
Charger		
Voltage	V/Hz	110...120/50...60
Power Input	W	300
Dimensions and weights		
Theoretical surface cleaning performance	m ² /h	1400
Fresh/waste water tank volume	l	12
Permissible overall weight	kg	48
Transport weight	kg	36
Length x width x height	mm	930x420x1100
Values determined as per EN 60335-2-72		
Total oscillation value	m/s ²	<2,5
Uncertainty K	m/s ²	0,2
Sound pressure level L _{pA}	dB(A)	65
Uncertainty K _{pA}	dB(A)	2
Sound power level L _{WA} + Uncertainty K _{WA}	dB(A)	84

Warranty

The warranty terms published by our competent sales company are applicable in each country. We will repair potential failures of your accessory within the warranty period free of charge, provided that such failure is caused by faulty material or defects in fabrication. In the event of a warranty claim please contact your dealer or the nearest authorized Customer Service center. Please submit the proof of purchase.

Spare parts

Only use original accessories and spare parts, they ensure the safe and trouble-free operation of the device. For information about accessories and spare parts, please visit www.kaercher.com.



THANK YOU!
MERCI! DANKE! ¡GRACIAS!



Registrieren Sie Ihr Produkt und profitieren Sie von vielen Vorteilen.

Register your product and benefit from many advantages.

Enregistrez votre produit et bénéficiez de nombreux avantages.

Registre su producto y aproveche de muchas ventajas.

www.kaercher.com/welcome



Bewerten Sie Ihr Produkt und sagen Sie uns Ihre Meinung.

Rate your product and tell us your opinion.

Évaluer votre produit et dites-nous votre opinion.

Reseñe su producto y díganos su opinión.



www.kaercher.com/dealersearch

Alfred Kärcher SE & Co. KG
Alfred-Kärcher-Str. 28-40
71364 Winnenden (Germany)
Tel.: +49 7195 14-0
Fax: +49 7195 14-2212

