

KÄRCHER

makes a difference

KM 90/60 R Bp Adv

KM 90/60 R Bp Pack Adv

KM 90/60 R Bp Pack Adv Edition

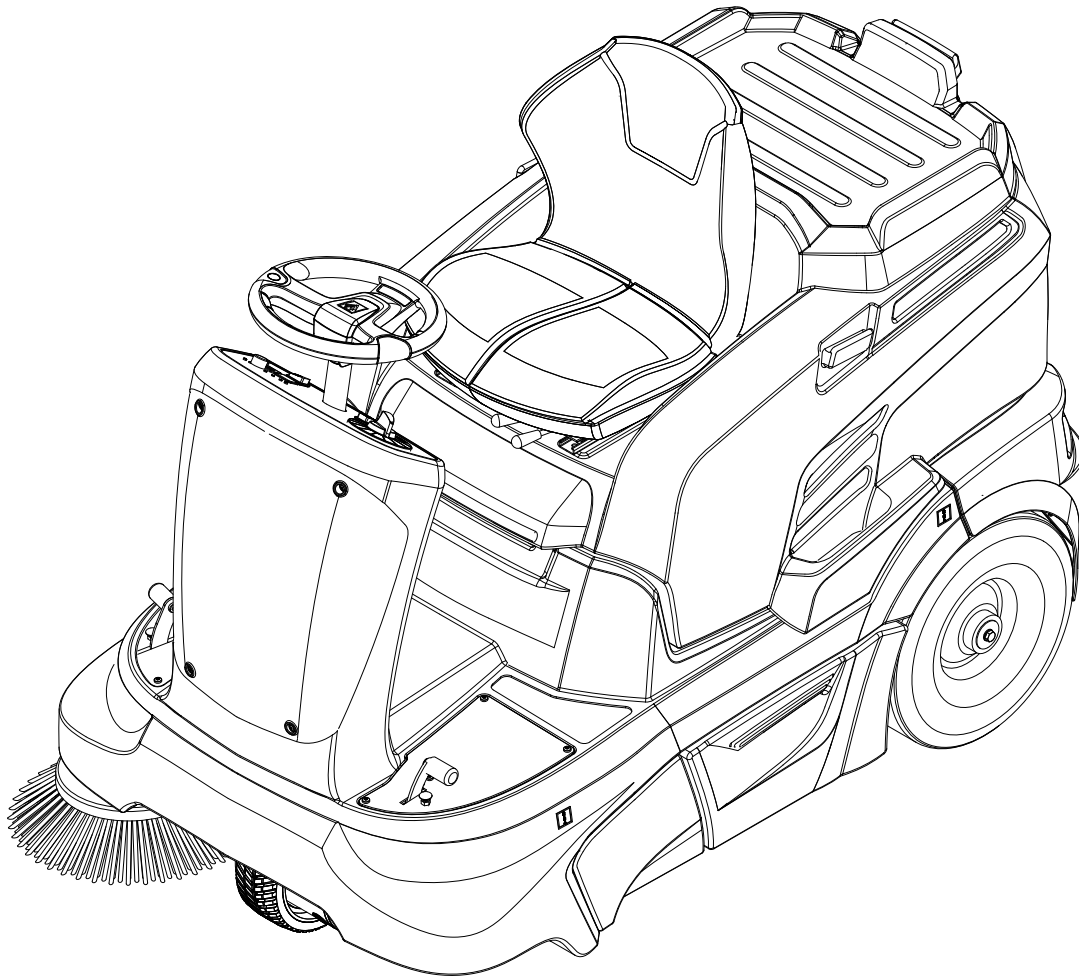

Deutsch	2
English	16
Français	29
Italiano	43
Nederlands	57
Español	71
Português	86
Dansk	101
Norsk	114
Svenska	127
Suomi	140
Ελληνικά	153
Türkçe	168
Русский	181
Magyar	198
Čeština	212
Slovenščina	225
Polski	238
Românește	252
Slovenčina	266
Hrvatski	279
Srpski	293
Български	307
Eesti	322
Latviešu	335
Lietuviškai	349
Українська	362



**Register
your product**



www.kaercher.com/welcome



EAC



59653290 10/19

  Please read and comply with these original instructions prior to the initial operation of your appliance and store them for later use or subsequent owners.

Please read the safety instructions before start-up!

Contents



General notes	EN	..	1
Proper use	EN	..	1
Safety instructions	EN	..	2
Function	EN	..	2
Operating and Functional Elements	EN	..	3
Before Startup	EN	..	4
Start up	EN	..	6
Operation	EN	..	6
Shutdown	EN	..	8
Care and maintenance	EN	..	8
Troubleshooting	EN	..	11
Technical specifications	EN	..	12
EC Declaration of Conformity	EN	..	13
Accessories	EN	..	13

General notes

Your sales outlet should be informed about any transit damage noted when unpacking the product.

- Warning and information plates on the machine provide important directions for safe operation.
- In addition to the information contained in the operating instructions, all statutory safety and accident prevention regulations must be observed.

Environmental protection

	The packaging material can be recycled. Please do not throw the packaging material into household waste; please send it for recycling.
	Old appliances contain valuable materials that can be recycled. Please arrange for the proper recycling of old appliances. Please dispose your old appliances using appropriate collection systems.

Notes about the ingredients (REACH)

You will find current information about the ingredients at:

www.kaercher.com/REACH

Warranty

The warranty terms published by the relevant sales company are applicable in each country. We will repair potential failures of your appliance within the warranty period free of charge, provided that such failure is caused by faulty material or defects in manufacturing. In the event of a warranty claim please contact your dealer or the nearest authorized Customer Service centre. Please submit the proof of purchase.

Accessories and Spare Parts

DANGER

To avoid risks, all repairs and replacement of spare parts may only be carried out by authorized customer service personnel.

- Only use accessories and spare parts which have been approved by the manufacturer. The exclusive use of original accessories and original spare parts ensures that the appliance can be operated safely and trouble free.
- For additional information about spare parts, please go to the Service section at www.kaercher.com.

Symbols in the operating instructions

DANGER

Warns about immediate danger which can lead to severe injuries or death.







WARNING

Warns about possible danger which could lead to severe injuries or death.

CAUTION

Points out a possibly dangerous situation which can lead to light injuries or property damage.

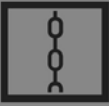
Symbols on the machine

	Please do not sweep away any burning substances such as cigarettes, match sticks or similar objects.
	Risk of being squeezed or hurt at the belts, side-brushes, containers, machine cover.
	Tyre pressure 0.425MPa 4.25bar
	Intake points for the jack
	Lashing point
	Wet/dry flap

Proper use

Use this sweeper only as directed in these operating instructions.

- This sweeper has been designed to sweep dirt and debris from outdoor surfaces.
- The machine is not suitable for being driven on public roads.
- Any use extending beyond this is not considered as proper use. The manufacturer is not liable for any losses resulting from this; the user alone bears the risk for this.
- The machine may not be modified.
- The machine is only suitable for use on the types of surfaces specified in the operating instructions.
- The machine may only be operated on the surfaces approved by the company or its authorised representatives.
- The following applies in general: Keep highly-flammable substances away from the appliance (danger of explosion/fire).

Foreseeable misuse

- Never vacuum up explosive liquids, combustible gases or undiluted acids and solvents. This includes petrol, paint thinner or heating oil which can generate explosive fumes or mixtures upon contact with the suction air. Acetone, undiluted acids and solvents must also be avoided as they can harm the materials on the machine.
- Never sweep/vacuum up reactive metal dusts (e.g. aluminium, magnesium, zinc), as they form explosive gases when they come in contact with highly alkaline or acidic detergents.
- The appliance is not suitable for sweeping off hazardous substances.
- Do not sweep/vacuum up any burning or glowing objects.
- The machine may not be used or stored in hazardous areas. It is not allowed to use the appliance in hazardous locations.
- It is strictly prohibited to take co-passengers.
- Pushing/pulling or transporting objects by means of this appliance is prohibited.

Suitable surfaces

- Asphalt
- Industrial floor
- Screed
- Concrete
- Paving stones

Safety instructions

Application

- The machine with working equipment must be checked to ensure that it is in proper working order and is operating safely prior to use. Otherwise, the appliance must not be used.
- If the appliance is used in hazardous areas (e.g. filling stations) the corresponding safety provisions must be observed. It is not allowed to use the appliance in hazardous locations.

Operation

- The appliance must not be operated by children or persons who have not been instructed accordingly.
- The appliance may be used by individuals with limited physical, sensory or cognitive abilities or lack of experience and knowledge if they are under supervision or were instructed regarding the safe use of the appliance and understand the resulting risks.
- The operator must use the appliance properly. The person must consider the local conditions and must pay attention to third parties, in particular children, when working with the appliance.
- Prior to starting work, the operator must ensure that all protective devices are properly installed and function correctly.
- The operator of the appliance is liable for accidents with other individuals or their property.
- Ensure that the operator wears tight-fitting clothes. Wear sturdy shoes and avoid wearing loose-fitting clothes.
- Check the immediate vicinity prior to starting (e.g. children). Ensure sufficient visibility!
- Never leave the machine unattended so long as the engine is running. The operator may leave the machine only when the engine has come to a standstill, the machine has been protected against accidental movement, if necessary, by applying the immobilization brake and the ignition key has been removed.
- The appliance may only be used by persons who have been instructed in handling the appliance or have proven qualification and expertise in operating the appliance or have been explicitly assigned the task of handling the appliance.
- Children should be supervised to prevent them from playing with the appliance.

Drive mode

⚠ Danger

Risk of injury!

- Danger of tipping if gradient is too high.
- The falling and rising gradients in the direction of travel may not exceed 12%.
- Danger of tipping on unstable ground.
- Only use the machine on sound surfaces.
- Danger of tipping with excessive sideways tilt.
- The gradient perpendicular to the direction of travel should not exceed 12%.

Battery-operated machines

Note

- Warranty claims will be entertained only if you use batteries and chargers recommended by Kärcher.
- Always follow the instructions of the battery manufacturer and the charger manufacturer. Please follow the statutory requirements for handling and disposing batteries.
 - Never leave the batteries in a discharged state; recharge them as soon as possible.
 - Always keep the batteries clean and dry to avoid creep currents. Protect the batteries and avoid contact with impurities such as metal dust.
 - Do not place tools or similar items on the battery. Risk of short-circuit and explosion.
 - Do not work with open flames, generate sparks or smoke in the vicinity of a battery or a battery charging room. Danger of explosion.
 - Do not touch hot parts of the machine such as the drive motor (risk of burns).
 - Be careful while handling battery acid. Follow the respective safety instructions!
 - Used batteries are to be disposed according to the EC guideline 91/ 157 EWG in an environment-friendly manner.

Transport

- The engine is to be brought to a standstill and the appliance is to be fastened properly during transportation.

Maintenance

- First switch off the appliance and remove the key before performing any cleaning or maintenance tasks on the appliance, replacing parts or switching over to another function.
- Do not clean the appliance with a water hose or high-pressure water jet (danger of short circuits or other damage).
- Maintenance work may only be carried out by approved customer service outlets or experts in this field who are familiar with the respective safety regulations.
- Please observe the local safety regulations regarding portable commercially used appliances.
- Always use appropriate gloves while working on the device.

Function

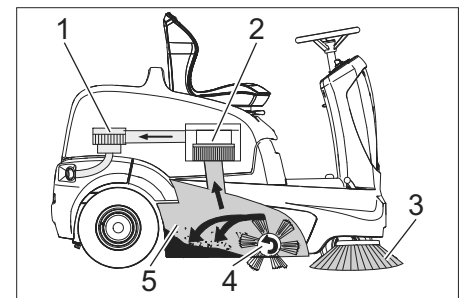

The sweeper operates using the overthrow principle.

- The side brushes (3) clean the corners and edges of the surface, moving dirt and debris into the path of the roller brush.
- The rotating roller brush (4) moves the dirt and debris directly into the waste container (5).
- The dust raised in the container is separated by the dust filter (2) and the filtered clean air is drawn off by the suction fan (1).
- The cleaning of the dust filter (2) takes place automatically.

Operating and Functional Elements

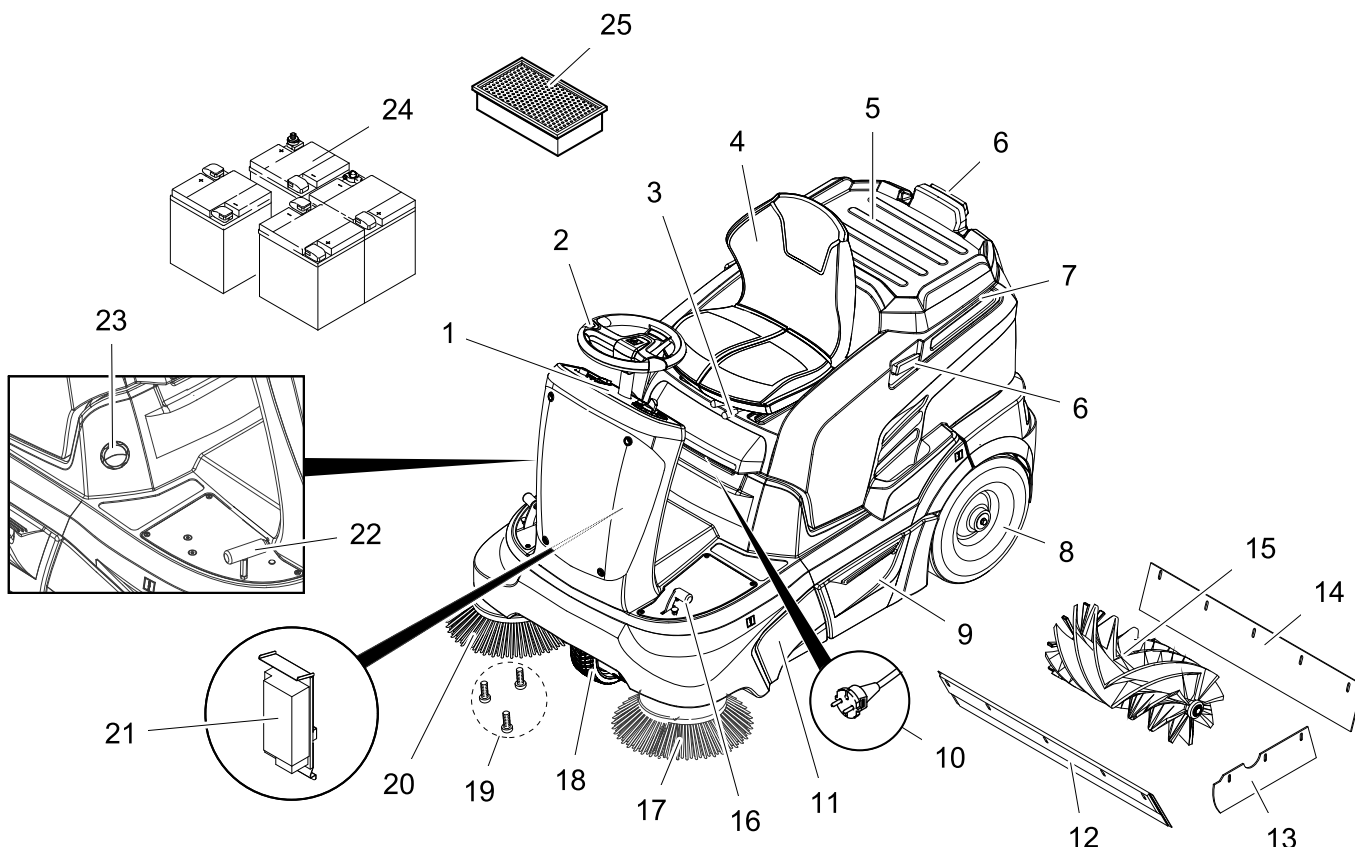

- 1 Operating field
- 2 Steering wheel
- 3 Lever for seat adjustment
- 4 Seat (with seat contact switch)
- 5 Storage area
- 6 Holding rail for home base
- 7 Cover
- 8 Rear wheel
- 9 Waste container (both sides)
- 10 Power cord plug of the charger (KM 90/60 R Bp Pack)
- 11 Roller brush access
- 12 Front sealing strip
- 13 Side sealing strip
- 14 Rear sealing strip
- 15 Roller brush
- 16 Pedal for raising/lowering bulk waste flap
- 17 Left side brush (optional)
- 18 Front wheel
- 19 Fastener of the side brush
- 20 Right side brush
- 21 Charger (KM 90/60 R Bp Pack: already installed) (KM 90/60 R Bp: not included in delivery)
- 22 Drive pedal
- 23 Wet/dry flap
- 24 Batteries (KM 90/60 R Bp Pack: already installed) (KM 90/60 R Bp: not included in delivery)
- 25 Dust filter (flat-fold filter)

Operating field

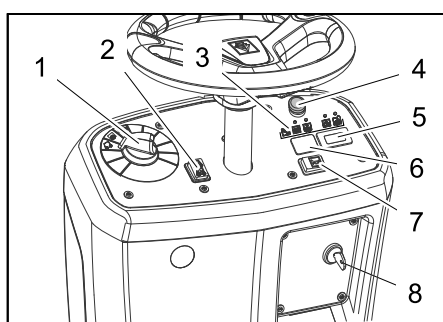

- 1 Programme switch
- 2 Travel direction switch (forward/reverse)
- 3 Indicator lamps
- 4 Emergency-stop button
- 5 Operating hour counter
- 6 Not assigned *
* prepared for the switch of the rotating beacon (option)
- 7 Horn
- 8 Key switch

Indicator lamps

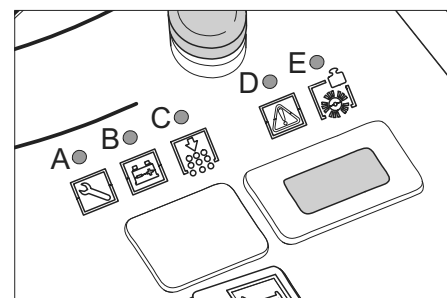

- A Service (yellow)
- B Battery charge status (red/yellow/green)
- C Overload of the filter cleaning (red)
- D Overload of the drive motor (red)
- E Overload of the sweep roller (red)

Parking brake

The appliance is equipped with an automatic parking brake that is integrated in the front-wheel drive. The parking brake acts as soon as the appliance comes to a standstill.

Before Startup

Open/ close device hood

⚠ DANGER

Danger of crushing while closing the machine cover. Hence, lower the machine cover slowly.

Prior to commissioning, maintenance or adjustment tasks, the appliance cover must be opened.

- Grab the front of the appliance cover and fold it back together with the seat.
- A retaining band keeps the appliance cover in the rear position.

Unloading tips

⚠ Danger

Risk of injury, risk of damage!

Observe the weight of the appliance when you load it!

Do not use a forklift truck to unload the machine as this may damage it.

Note

Press the emergency-stop button to immediately deactivate all functions and turn the key switch to the "0" position.

Weight (without batteries)	205 kg *
Weight (with batteries)	335 kg *
* If upgrade kits are installed, the weight is respectively higher.	

- Use a suitable ramp or a crane to load the appliance!
 - If the machine is delivered on a pallet, you must create an unloading ramp using the boards provided.
- To unload the machine, proceed as follows:
- Cut plastic packing belt and remove foil.
 - Remove the elastic tape fasteners at the stop points.
 - Four indicated floor boards of the pallet are fastened with screws. Unscrew these boards.
 - Place the boards on the edge of the pallet. Place the boards in such a way that they lie in front of the four wheels of the machine. Fasten the boards with screws.

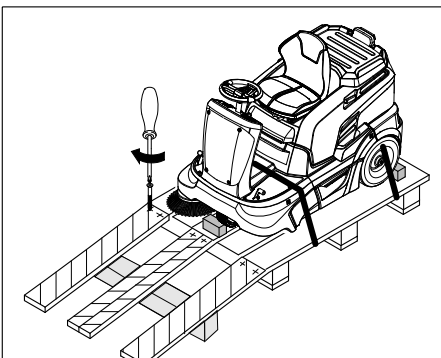

- Slide the four support beams included in the packaging under the ramp.
- Remove the wooden blocks used for arresting the wheels and slide them under the ramp.

Push the sweeper off the pallet (appliance without built-in battery)

⚠ DANGER

- Risk of injury! Before releasing the immobilizing brake, the machine must be secured to prevent it rolling away. After releasing the emergency brake, the appliance will roll until a speed of 4.5 km/h is reached. After that, the electronics will brake the appliance.
 - It is prohibited to release the emergency brake on an incline without using the stopper.
- Release parking brake.

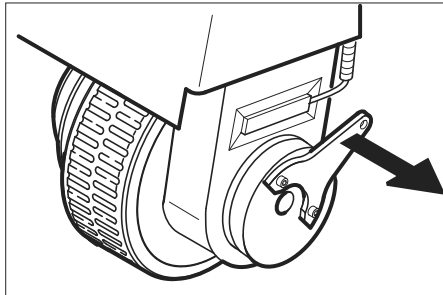

- Remove the brake level from the wheel and put it in its position. The immobilizing brake is thus deactivated; the machine can now be moved.
- Slide the machine over the prepared ramp from the pallet.

Drive the sweeper off the pallet (appliance with built-in battery)

- Connect the battery, refer to Chapter "Connecting and installing the battery".
- Release emergency-stop button by turning.
- Set main switch to "1".
- Press the drive direction switch and slowly move the machine down from the ramp.
- Set main switch back to "0".

Batteries

Safety notes regarding the batteries

Please observe the following warning notes when handling batteries:

	Observe the directions on the battery, in the instructions for use and in the vehicle operating instructions!
	Wear an eye shield!
	Keep away children from acid and batteries!
	Risk of explosion!
	Fire, sparks, open light, and smoking not allowed!

	Danger of causticization!
	First aid!
	Warning note!
	Disposal!
	Do not throw the battery in the dustbin!

⚠ Danger

Risk of explosion! Do not put tools or similar on the battery, i.e. on the terminal poles and cell connectors.

⚠ Danger

Risk of injury! Ensure that wounds never come into contact with lead. Always clean your hands after having worked with batteries.

⚠ Danger

Risk of fire and explosion!

- Smoking and naked flames are strictly prohibited.
- Rooms where batteries are charged must have good ventilation because highly explosive gas is emitted during charging.
- Batteries must not be stored outside.

⚠ Danger

Danger of causticization!

- Rinse thoroughly with lots of clear water if acid gets into the eye or comes in contact with the skin.
- Then consult a doctor immediately.
- Wash off the acid if it comes in contact with the clothes.

Recommended batteries, chargers

We recommend the use of our batteries and chargers as listed below.

NOTICE

With the KM 90/60 R Bp pack, the battery and charger are already built in.

Order No.	Description	
6.654-124.0 ³⁾	180 Ah - maintenance-free	6 V**

** Appliance requires 4 batteries

³⁾ Complete set (24 V/180 Ah) incl. connecting cable, order no. 4.035-387.0

Order No.	Description
6.654-125.0	Charger for maintenance-free batteries

Using batteries made by other manufacturers

Note

Warranty claims will be entertained only if you use batteries and chargers recommended by Kärcher.

Note

When using batteries of other manufacturers, the maximum battery dimensions must be observed.

Maximum battery dimensions (single battery)

The appliance requires 4 single batteries with 6 volt each.

Length	Width	Height
264 mm	190 mm	284 mm

Pay attention to the following if you are using maintenance-free batteries in KM 90/60 R Bp:

- It is necessary to conform to the maximum battery dimensions.
- While charging maintenance-free batteries, it is necessary to tilt the appliance hood upward.
- While charging maintenance-free batteries, follow the specifications of the battery manufacturer.

Installing and connecting the batteries

- ➔ Open the device hood.
- ➔ Insert batteries into the battery mount.
- ➔ Adjust the rubber buffers to hold the batteries properly.

⚠ Warning

Pay attention to correct poles.

NOTICE

The connection lines are not included in the delivery scope.

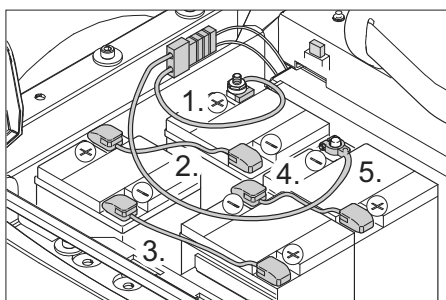

The illustration shows KM 90/60 R Bp with retrofitted and connected batteries, as well as with charge plug for external charger.

Note on KM 90/60 R Bp Pack: The charger and the battery pack are already installed and connected by the factory, a charge plug is not present.

- ➔ Connect pole terminal (red cable) to positive pole (+).
- ➔ Screw the connection lines onto the batteries.
- ➔ Connect pole terminal to negative pole (-).

Note

Before removing the battery, make sure that the negative pole lead is disconnected. Check that the battery pole and pole terminals are adequately protected with pole grease.

⚠ WARNING

Charge the batteries before commissioning the machine.

Charge the batteries

⚠ Danger

Risk of injury! Comply with safety regulations on the handling of batteries. Observe the directions provided by the manufacturer of the charger.

⚠ DANGER

Charge the battery only with an appropriate charger.

NOTICE

When the batteries are charged, first remove the charger from the mains and then disconnect it from the batteries.

(1) Charging procedure KM 90/60 R Bp Pack

⚠ Danger

Risk of injury! The charger should be used only if the mains connection line is in an undamaged state. Get the manufacturer, the customer service agent or a qualified person to immediately replace a damaged mains connection line.

NOTICE

Normally, the machine is equipped with maintenance-free batteries.

- ➔ Open the device hood.

- ➔ Insert the plug of the charger into the socket.

Note

The charger has electronic controls and automatically switches off the charging process. All functions of the machine are automatically interrupted during the charging process.

The battery control display shows the progress of the charging process when the plug is inserted:

Battery fault	A=blinks yellow, B=off, C+D+E=red
Battery is being charged	glows yellow
Battery is charged	glows green
Charger error	A=blinks yellow, B+E=red, C+D=off

(2) Charging procedure KM 90/60 R Bp

- ➔ Open the device hood.
- ➔ Separate the battery plug and connect the charger cable.

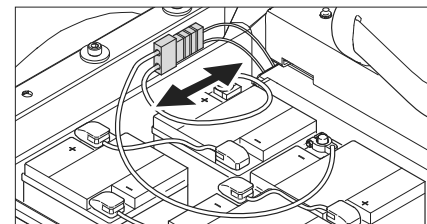

- ➔ Plug in mains connector and switch on charger.

Note

The recommended chargers (matching the batteries used) are regulated electronically and will automatically switch off the charging process. All functions of the machine are automatically interrupted during the charging process.

Low maintenance batteries

- ➔ Add distilled water one hour before the charging process comes to an end; follow the correct acid level. There are corresponding indicators on the battery.

⚠ DANGER

Danger of causticization! Adding water to the battery in its discharged state can cause the acid to leak.

Wear protective glasses and protective clothing when handling battery acid. Observe the regulations concerning the handling of batteries!

⚠ DANGER

Danger of causticization!

- Rinse thoroughly with lots of clear water if acid gets into the eye or comes in contact with the skin.
- Then consult a doctor immediately.
- Change clothing.
- Wash off the acid if it comes in contact with the clothes.

⚠ Warning

Risk of damage. Use only distilled or desalinated water (VDE 0510) for filling the battery. Do not add any substances (so-called performance improving agents), else warranty claims will not be entertained.

After charging

- ➔ Switch off the charger and remove the plug from the socket.
- ➔ If the machine does not have a built-in charger: Pull the battery cable from the charger cable and connect it to the appliance.

Check and correct the fluid level of the battery (only for low-maintenance batteries)

⚠ Warning

Regularly check the fluid level in acid-filled batteries.

- The acid in a fully charged battery has a specific weight of 1.28 kg/l at a temperature of 20 °C.
- The acid in a partially discharged battery has a specific weight between 1.00 and 1.28 kg/l.
- The specific weight of the acid must be uniform in all cells.
- Unscrew all cell caps.
- Take a sample from each cell using the acid tester.
- Put the acid sample back into the same cell.
- Where fluid level is too low, top up cells to the mark provided with distilled water.
- Charge battery.
- Screw in cell caps.

Start up

General notes

The appliance will brake electrically while standing still, if one of the following conditions is met.

- Foot was removed from the pedal.
- Operator's seat was left for more than 1 second.
- Key switch was set to "0".

The automatic emergency brake will only work while the appliance is at a standstill.

- Park the sweeper on an even surface.
- Remove the key.

Prior to start/safety test

- Check charging status of battery.
- Check side brush.
- Check the roller brush for wear and wrapped belts.
- Empty waste container.
- Check tyre pressure.
- Check function of seat contact switch.

Note: For description, see section on Care and maintenance.

Operation

Adjusting driver's seat

- Pull seat adjustment lever inwards.
- Slide seat, release lever and lock in place.
- Check that the seat is properly locked in position by attempting to move it backwards and forwards.

Check charging status of battery

- **Indicator lamp glows green**
Battery is charged (100...40%).
 - **Indicator lamp glows yellow**
Battery is discharged to 40 ... 20%.
 - **Indicator lamp blinks red**
Battery is almost discharged. The sweeping mode will be shortly switched off automatically.
 - **Indicator lamp glows red**
Battery is discharged. The sweeping mode will be terminated automatically (the sweeping aggregates cannot be taken into operation until the battery is charged).
- Drive the machine directly to the charging station; avoid any steep gradients in the process.
 - Charge battery.

Check immobilizing brake

⚠ Danger

Danger of accident. The immobilizing brake must always be checked first on an even surface before starting the machine.

- Take the seating position.
- Release emergency-stop button by turning.
- Set main switch to "1".
- Activate the travel direction switch (forward/reverse).
- Gently depress drive pedal.
The break must unlock audibly and smoothly start rolling on a level ground.
- Release the drive pedal.
When the drive pedal is released, the brake must brake in an audible manner.

Note: If this is not the case, put the appliance out of operation and call the customer service.

Storage area

Note: The max. load of the storage area is 20 kg.

- Ensure safe fastening of the cargo.

Emergency-stop button

- The appliance has an emergency OFF switch. If this switch is pressed, the appliance will stop abruptly and the automatic emergency brake will be activated.
- In order to restart the appliance, first unlock the emergency OFF switch, then turn the key switch on and off.

Programme selection

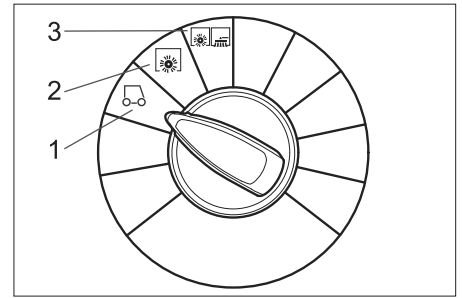

1 Driving

Driving to the Place of Use.

Side brush and roller brush are raised.

2 Sweeping with sweep roller

Roller brush is lowered.

3 Sweeping using roller brush and side brushes

Roller brush and side brushes are lowered.

Turning on the Appliance

NOTICE

The machine is equipped with a seat contact switch. When you quit the driver seat, the machine comes to a halt after a delay of approx. 1.5 seconds and the activated sweep function is switched off.

- Sit on the driver's seat.
- Do NOT press the accelerator pedal.
- Set programme switch to step 1 (driving).
- Set main switch to "1".

Drive the machine

⚠ Danger

Danger of accident! If the machine does not brake, then proceed as follows:

- If the device does not come to a halt on a ramp with a gradient of 2% when you release the drive pedal, then the emergency-stop button may be pressed for safety reasons only if the mechanical functioning of the immobilizing brake has been checked properly before commissioning the device.
- Switch off the machine only after it comes to a complete halt (on an even surface) and call up the aftersales service!
- Further, follow all warning instructions for braking.
- Release emergency-stop button by turning.
- Sit on the seat and set main switch to "1".

Drive forward

- Set the travel direction switch to "forward".
- Press accelerator pedal down slowly.

Reverse drive

⚠ DANGER

- Risk of injury! While reversing, ensure that there is nobody in the way, ask them to move if somebody is around.
 - During reverse drive, a pulsing warning sound will be heard.
 - The reverse drive speed is lower than the forward speed for safety reasons.
- Set the travel direction switch to "backwards".
- Press accelerator pedal down slowly.

Note

The accelerator pedal can be used to vary the driving speed infinitely.

Brakes

- Release the accelerator pedal, the machine brakes automatically and stops.

Driving over obstacles

CAUTION

Objects or loose obstacles may not be run over or pushed.

- Stationary obstacles of up to 5 cm can be run over slowly and carefully.
- Stationary obstacles of more than 5 cm may only be run over using a suitable ramp.

Overload of the drive motor

In case of overloading, the drive motor automatically switches off after a certain period. The indicator lamp "Overload of the drive motor" will illuminate red as soon as the drive motor current is limited. If the control is overheated, all drives (except for the horn and the filter cleaning) will be switched off.

- Allow machine to cool down at least for 15 minutes.
- Turn the main switch to "0" and turn it back to "1".

Sweeping mode

⚠ Danger

Risk of injury! If the bulk waste flap is open, stones or gravel may be flung forwards by the roller brush. Make sure that this does not endanger persons, animals or objects.

CAUTION

Do not sweep up packing strips, wire or similar objects as this may damage the sweeping mechanism.

CAUTION

To avoid damaging the floor, do not continue to operate the sweeping machine in the same position.

Note: To achieve an optimum cleaning result, the driving speed should be adjusted to take specific situations into account.

Note: During operation, the waste container should be emptied at regular intervals.

Note: When cleaning surfaces, only lower the roller brush.

Note: Also lower side brush when cleaning along edges.

Sweeping with sweep roller

- Set programme switch to step 2. Roller brush is lowered.

Note: Roller brush starts operating automatically.

Sweeping with bulk waste flap raised

Note: To sweep up larger items up to a height of 50 mm, e.g. cigarette packs, the bulk waste flap must be raised briefly.

Raising bulk waste flap:

- Press the pedal for the bulk waste flap forwards and keep pressed down.

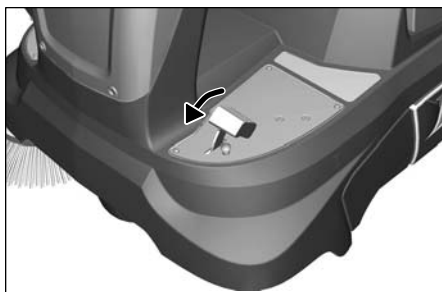

- To lower it, take foot off pedal.

Note: An optimum cleaning result can only be achieved if the bulk waste flap has been lowered completely.

Sweeping with side brushes

- Set programme switch to step 3. Side brushes and roller brush are lowered.

Note: Roller brush and side brush start operating automatically.

Sweeping dry floors

- Close wet/dry flap

Sweep in fibrous and dry waste (such as dry grass, hay)

- Open wet/dry flap.

Note: You can thus prevent the filter system from getting blocked.

Sweeping damp or wet floors

- Open wet/dry flap.

Note: This protects the filter from moisture.

Filter dedusting

The appliance is equipped with an automatic filter cleaning system. The cleaning takes place automatically approx. every 15 seconds. In the process a short blow-off sound can be heard.

- Check the installed dust filter for contamination every once in a while. Replace a heavily contaminated or defective filter.

Emptying waste container

Note: Wait until the automatic filter shaking process is finished and the dust has settled before you open or empty the waste container.

- Raise the waste container slightly and pull it out.

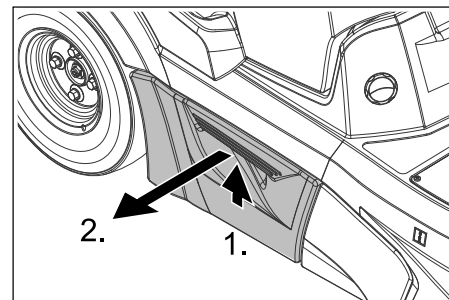

- Empty waste container.
- Push in the waste container and lock it.
- Empty opposite waste container.

Turn off the appliance

Note: After switching off the appliance, the dust filter is automatically cleaned. Wait for approx. 2 minutes before opening the appliance cover.

- Set programme switch to step 1 (driving). The side brush and roller brush are raised.

- Turn main key to "0" and remove it.

Note

The appliance has an automatic switch-off function to protect the batteries from discharging. If the appliance is not in use (with the key switch turned on) for longer than 30 minutes, it will switch off automatically.

Transport

⚠ DANGER

Risk of injury and damage! Observe the weight of the appliance when you transport it.

- Turn main key to "0" and remove it.
- Secure the wheels of the machine with wheel chocks.
- Secure the machine with tensioning straps or cables.
- When transporting in vehicles, secure the appliance according to the guidelines from slipping and tipping over.

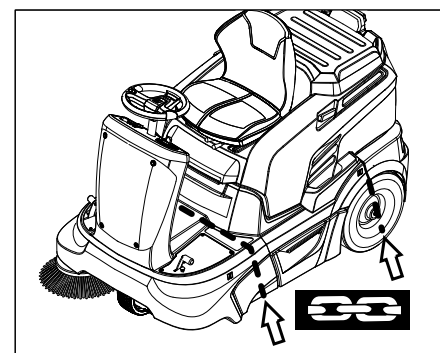

NOTICE

Observe markings for fixing points on base frame (chain symbols). When loading or unloading the machine, it may only be operated on gradients of max. 12%.

Storage

⚠ DANGER

Risk of injury and damage! Note the weight of the appliance in case of storage.

Shutdown

If the sweeper is going to be out of service for a longer time period, observe the following points:

- Park the sweeper on an even surface.
- Set programme switch to step 1 (driving). The roller brush and side brushes are raised to prevent the bristles being damaged.
- Turn main key to "0" and remove it.
- Lock the sweeper to ensure that it does not roll off.
- Clean the inside and outside of the sweeper.
- Park the machine in a safe and dry place.
- Disconnect battery.
- Charge battery and recharge it approx. every 2 months.

Care and maintenance

General notes

- First switch off the appliance and remove the key before performing any cleaning or maintenance tasks on the appliance, replacing parts or switching over to another function.
- Pull out the battery plug or clamp the battery while working on the electrical unit.
- Maintenance work may only be carried out by approved customer service outlets or experts in this field who are familiar with the respective safety regulations.
- Mobile appliances used for commercial purposes are subject to safety inspections according to VDE 0701.
- Use only roller brushes/ side-brushes that are provided with the appliance or specified in the Operations Manual. The use of other roller brushes/ side-brushes can affect the safety of the appliance.

Cleaning

CAUTION

Risk of damage! Do not clean the appliance with a water hose or high-pressure water jet (danger of short circuits or other damage). Do not use aggressive and abrasive detergents.

Cleaning the inside of the machine

⚠ Danger

Risk of injury! Wear dust mask and protective goggles.

- Open the device hood.
- Blow through machine with compressed air.
- Clean the machine with a damp cloth which has been soaked in mild detergent.
- Close cover.

External cleaning of the appliance

- Clean the machine with a damp cloth which has been soaked in mild detergent.

Maintenance intervals

Observe the inspection checklist!

Note: The elapsed-time counter shows the timing of the maintenance intervals.

Maintenance by the customer

Note: Where maintenance is carried out by the customer, all service and maintenance work must be undertaken by a qualified specialist. If required, a specialised Kärcher dealer may be contacted at any time.

Daily maintenance:

- Check the sweeping roller and the side brush for wear and wrapped belts.
- Check tyre pressure.
- Check function of all operator control elements.

Weekly maintenance:

- Check fluid level of battery.
- Check moving parts for freedom of movement.
- Check the sealing strips in the sweeping area for position and wear.
- Check dust filter and clean filter box, if required.
- Check function of seat contact switch.

Maintenance to be carried out every 100 operating hours:

- Check battery acid level.
- Check tension, wear and function of drive belts (V-belt and circular belt).

Maintenance following wear:

- Replace sealing strips.
- Replace roller brush.
- Replace side brush.

Note: For description, see section on Maintenance work.

Maintenance by Customer Service

Note: In order to safeguard warranty claims, all service and maintenance work during the warranty period must be carried out by the authorised Kärcher Customer Service in accordance with the maintenance booklet.

Maintenance to be carried out after 5 operating hours:

- Carry out initial inspection.

Maintenance to be carried out every 50 operating hours

- Have maintenance tasks performed according to the inspection check list.

Maintenance to be carried out every 100 operating hours

- Have maintenance tasks performed according to the inspection check list.

Maintenance Works

General notes on safety

⚠ Danger

Risk of injury! Allow the machine sufficient time to cool down before carrying out any maintenance and repair work.

Preparation

- Park the sweeper on an even surface.
- Turn main key to "0" and remove it.
- Press emergency-stop button.
- Allow device to cool down sufficiently.

Check fluid level in the battery and adjust if required

⚠ Warning

Regularly check the fluid level in acid-filled batteries.

- Unscrew all cell caps.
- Where fluid level is too low, top up cells to the mark provided with distilled water.
- Charge battery.
- Screw in cell caps.

Check the tyre pressure

- Park the sweeper on an even surface.
- Connect air pressure testing device to tyre valve.
- Check air pressure and adjust if required.
For permissible tyre inflation pressure see Chapter "Technical specifications".

Replacing wheel

- Park the sweeper on an even surface.
- Turn main key to "0" and remove it.
- Check stability of ground. Lock the appliance to ensure that it does not roll off.
- Raise slightly the waste container on the appropriate side and pull it out.

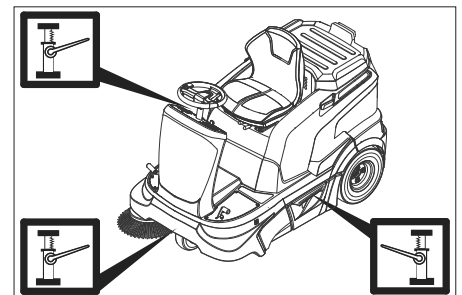

- Position vehicle jack at the appropriate mounting point for the front or rear wheel.

Note

Use a suitable commercially available vehicle jack.

- Loosen the wheel nuts/wheel bolts by about 1 revolution using a suitable tool.
- Raise machine using vehicle jack.
- Unscrew the wheel nuts/wheel bolts and remove them.
- Remove wheel.
- Have the defective wheel repaired by a specialised repair shop.
- Place the wheel and screw in the wheel nuts/wheel bolts all the way; tighten them lightly.
- Lower machine using vehicle jack.

- Torque the wheel nuts/wheel bolts to the required torque.
Tightening torque 120 Nm
- Push in the waste container and lock it.

Checking the sweeping mirror of the side-brushes

- Check tyre pressure.
- The side-brushes lift up.
- Drive sweeper on to a smooth, even surface covered with a visible layer of dust or chalk.
- Lower side-brushes and allow them to briefly rotate.
- The side-brushes lift up.
- Drive machine backwards.
- Park the sweeper on an even surface.
- Check sweeping mirror.

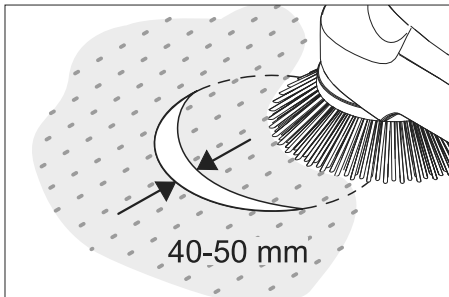

The width of the sweeping track should lie between 40-50 mm.

Note

The side brush floating mounting adjusts the sweeping track as the bristles wear down. The side brush must be replaced if it becomes too worn.

Replacing side brush

- Park the sweeper on an even surface.
- Set programme switch to step 1 (driving). Side brushes lift up.
- Turn main key to "0" and remove it.
- Loosen 3 fastening screws on the underside.
- Clip side brush on to driver and screw on.

Checking roller brush

- Park the sweeper on an even surface.
- Set programme switch to step 1 (driving). Roller brush is raised.
- Turn main key to "0" and remove it.
- Secure the machine with wheel chock(s) to prevent it from rolling away.
- Remove belts or cords from roller brush.

Check the sweeping mirror of the sweeping roller

- Set programme switch to step 1 (driving). The side brush and roller brush are raised.
- Drive sweeper on to a smooth, even surface covered with a visible layer of dust or chalk.
- Set programme switch to step 2. Roller brush is lowered. Slightly press down on the drive pedal and allow the sweep brush to briefly rotate.
- Raise roller brush.

- Press pedal which raises bulk waste flap and keep pressed.
- Drive machine backwards.

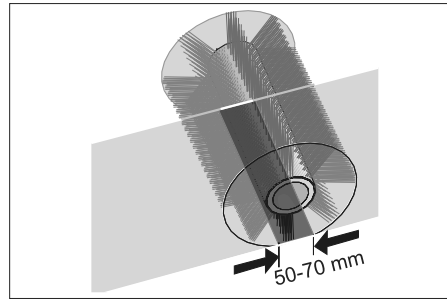

The sweeping track should have an even rectangular shape which is between 50 and 70 mm wide.

NOTICE

The side brush floating mounting of the roller brush adjusts the sweeping track as the bristles wear down. The roller brush must be replaced if it becomes too worn.

Replacing roller brush

Replacement is due if a visible deterioration in sweeping performance caused by bristle wear is evident.

- Park the sweeper on an even surface.
- Set programme switch to step 1 (driving). Roller brush is raised.
- Turn ignition key to "0" and remove it.
- Secure the machine with wheel chock(s) to prevent it from rolling away.
- Raise slightly the waste container on the left side and pull it out.

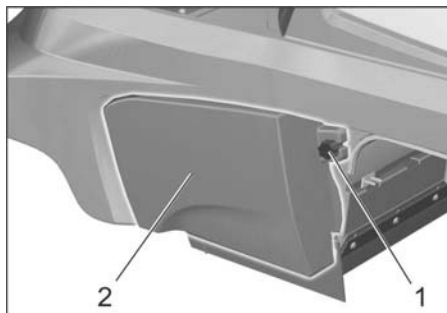

- 1 Screw
- 2 Side panels

- Loosen the fastening screw on the left side-panel.
- Remove side panel.

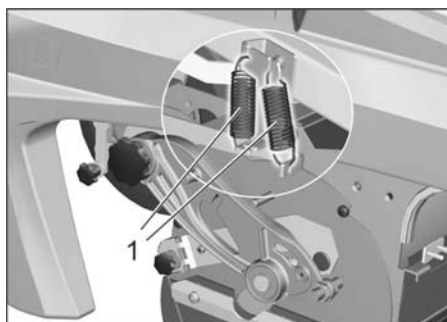

- 1 Spring

- Unhook both draw springs.

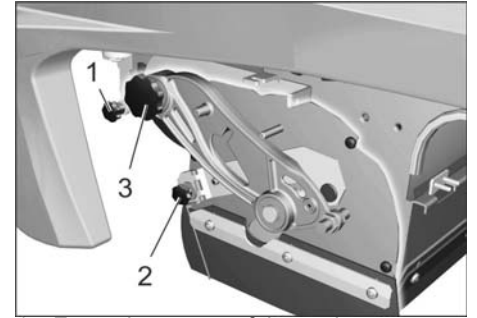

- 1 Fastening screw of the under-pressure can
- 2 Fastening nut of the bulk waste flap
- 3 Screw of the roller brush crank

- Unscrew the fastening screws of the vacuum socket and release the lever.
- Turn the fastening nut of the bulk waste flap and unhook the bulk waste flap.
- Unscrew and withdraw bolt on the roller brush swinging arm.

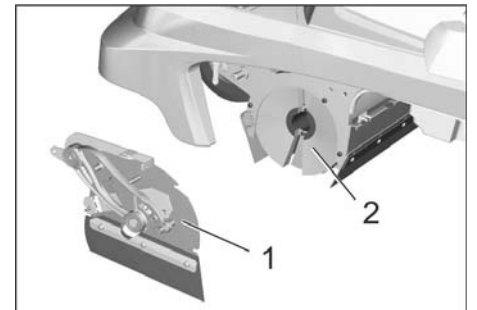

- 1 Cover
- 2 Roller brush

- Push the roller brush cover backwards and remove it.
- Pull out roller brush.
- Push new roller brush into the roller brush housing and onto the drive pin.
Note: When installing the new roller brush, ensure correct positioning of the bristle assembly.

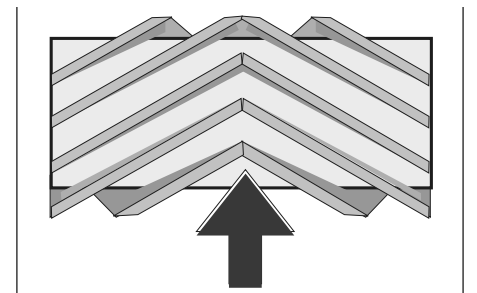

Installation position of roller brush in direction of travel

- Position roller brush cover.
- Fit the fastening screws and nuts.
- Hook the draw spring in.
- Screw on side panel.
- Push in the waste containers on both the sides and lock them.

Adjusting and replacing sealing strips

- Park the sweeper on an even surface.
- Set programme switch to step 1 (driving). Roller brush is raised.
- Turn main key to "0" and remove it.
- Press emergency-stop button.
- Secure the machine with wheel chock(s) to prevent it from rolling away.
- Raise slightly the waste containers on both sides and pull them out.
- Open the fastening screws of the side panels on both sides.
- Remove side panels.
- **Front sealing strip**
- Loosen retaining nuts for the front sealing strip (1) slightly (to replace, unscrew).
- Screw on new sealing strip without fully tightening the nuts.

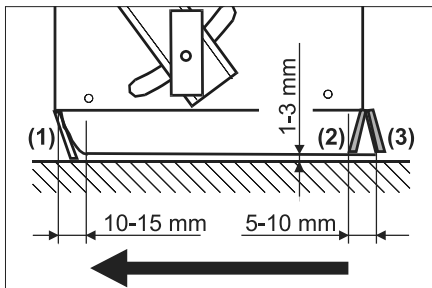

- Adjust sealing strip.
- Set the distance between the sealing strip and the floor so that the bottom edge trails behind at a distance of between 10-15 mm.
- Tighten nuts.

■ Rubber strip

- If worn, replace.
- Unscrew retaining nuts for the rubber strip (2).
- Screw on new rubber strip.
- **Rear sealing strip**
- Set the distance between the sealing strip and the floor so that the bottom edge trails behind at a distance of between 5 and 10 mm.

- If worn, replace.
- Unscrew retaining nuts for rear sealing strip (3).
- Screw on new sealing strip.

■ Side sealing strips

- Slightly loosen retaining nuts for the side sealing strip (to replace, unscrew).
- Screw on new sealing strip without fully tightening the nuts.
- To set the floor clearance, insert a sheet with a thickness of between 1 and 3 mm under the sealing strip.
- Adjust sealing strip.
- Tighten nuts.
- Screw on side panels.
- Push in the waste containers on both the sides and lock them.

Check/replace dust filter

⚠ WARNING

Wear a dust mask when working around the dust filter. Observe safety regulations on the handling of fine particles.

- Note:** Wait at least 1 minute before removing the dust filter so that the dust can settle.
- Open the device hood.

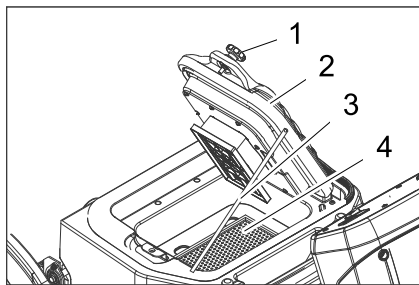

- 1 Screws (2x)
- 2 Lid with cleaning device
- 3 Support
- 4 Dust filter (flat-fold filter)

- Loosen the screws.
- Fold the lid up and secure it by means of the support.
- Take out the dust filter.
- Check dust filter, clean or replace
- Insert cleaned or new dust filter.
- Close the lid.
- Tighten the screws.

Check suction blower

- Check hose at the suction blower for tightness.

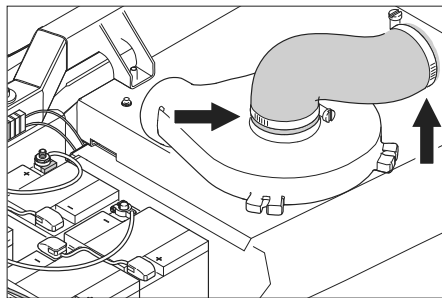

Checking drive belt

- Turn main key to "0" and remove it.
- Press emergency-stop button.
- Open the device hood.

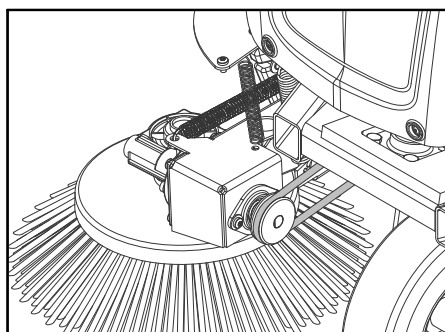

- Check tension of circular belt of the side-brush; also check for wear or damage.

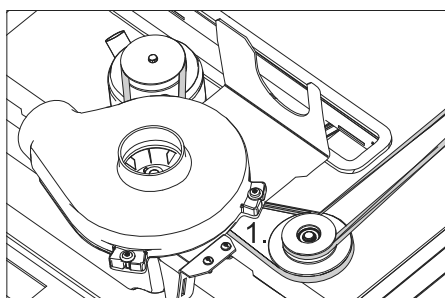

- Check tension, wear and damages on the V-belt of the sweep roller drive.

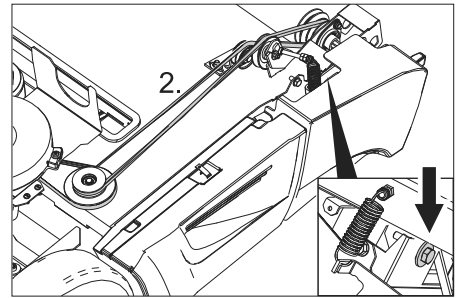

- Check tension, wear and damages on the V-belt of the sweep roller drive.

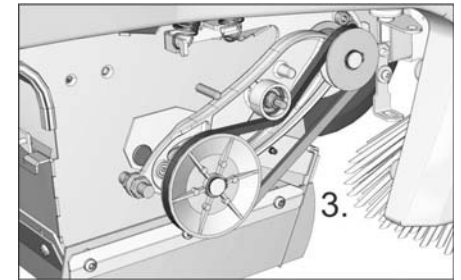

- Check tension, wear and damages on the V-belt of the sweep roller drive.
- Tighten the V-belt at the screw if necessary.

Replacing the fuse

- Replace defective fuse.

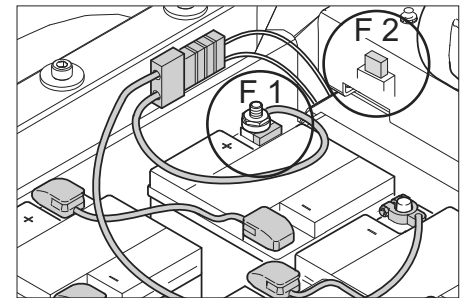

F 1	Main fuse Battery pole fuse	150 A
F 2	Automotive flat plug fuse Vacuum pump	3 A
F 5	Automotive flat plug fuse Beacon light (optional) Note: This fuse is located underneath the front panel on the left hand side	7,5 A

■ Pole fuse

NOTICE

A defective pole fuse may only be replaced by a Kärcher service technician or an authorised expert. If this fuse is defective, check the usage conditions and the entire control system.

■ Fuse rotating beacon (option)

To replace a fuse, the front panel must be removed.

- Loosen the front panel screws.
- Remove front panel.
- Replace defective fuse.

Troubleshooting

Fault	Remedy
Machine does not move	Sit on the driver seat, the seat contact switch gets activated.
	Release emergency-stop button
	Plug in the battery plug (KM 90/60 R Bp)
	Set main switch to "1"
	Check fuse F1, have it replaced by Kärcher customer service if required.
	Check charging status of battery. Charge the battery if required.
	Inform Kärcher Customer Service.
Machine is not sweeping properly	Check roller brush and side brushes for wear, replace if necessary.
	Check function of bulk waste flap
	Check sealing strips for wear, adjust or replace as required
	Check belts of sweeping drive.
	Inform Kärcher Customer Service.
Dust gathers in the machine Insufficient vacuum performance	Empty waste container
	Check hoses of suction blower for absence of leakiness.
	Clean and check the dust filter, replace if necessary.
	Check the dust filter for proper seating.
	Close wet/dry flap
	Check sealing strips for wear, adjust or replace as required Inform Kärcher Customer Service.
Side brush or roller brush is not being lowered	Check fuse F2, replace if required.
	Inform Kärcher Customer Service.
Roller brush does not turn.	Set programme switch to stage 2 or 3.
	Remove belts or cords from roller brush
	Check V-belt tension
	Inform Kärcher Customer Service.
A short blow-off sound can be heard.	The appliance is OK, the automatic filter cleaning system is working
Error code is displayed.	Completely switch of the appliance and turn it back on.
	If this error recurs, please contact the Kärcher customer service department

Error code

Indicator lamp - service	Indicator lamp - battery charge status indicator	Indicator lamp - Overload of the filter cleaning	Indicator lamp - overload of the drive motor	Indicator lamp - Overload of the sweep roller	Significance
yellow	green/yellow/red	red	red	red	
blinking	--	--	--	x	Press emergency-stop button.
blinking	--	--	x	--	Overtemperature on the circuit board
blinking	--	--	x	x	Battery voltage defective
blinking	--	x	--	--	Drive pedal error
blinking	--	x	--	x	Line interruption, electrical consumers
blinking	--	x	x	--	Short circuit, electrical consumers
blinking	--	x	x	x	Error while charging
blinking	x	--	--	--	Performance module defective
blinking	x	--	--	x	Built-in charging device defective
blinking	x	--	x	--	General contactor does not open
Off	Not important	x	--	--	Overload of the filter cleaning
Off	Not important	--	x	--	Overload of the drive motor
Off	Not important	--	--	x	Overload of the sweep roller

Technical specifications

		KM 90/60 R Bp Adv	KM 90/60 R Bp Pack Adv (Edition)
Machine data			
Length x width x height	mm	1695 x 1060 x 1260	1695 x 1060 x 1260
Unladen weight	kg	205	335
Permissible overall weight	kg	530	530
Driving speed	km/h	6	6
Cleaning speed	km/h	6	6
Climbing capability (max.)	%	12	12
Roller brush diameter	mm	250	250
Roller brush width	mm	615	615
Side brush diameter	mm	410	410
Surface cleaning performance without side brushes	m ² /h	3690	3690
Surface cleaning performance with 1 side brushes	m ² /h	5400	5400
Surface cleaning performance with 2 side brushes	m ² /h	7110	7110
Working width without side brushes	mm	615	615
Working width with 1 side brushes	mm	900	900
Working width with 2 side brushes	mm	1185	1185
Volume of waste container	l	60	60
Protection type, drip-proof	--	IPX 3	IPX 3
Motors			
- Drive motor			
Type	--	Inverse speed motor for forward and reverse drive	Inverse speed motor for forward and reverse drive
Type	--	Wheel hub motor in front wheel	Wheel hub motor in front wheel
Voltage	V	24	24
Rated current	A	40	40
Rated power (mechanical)	W	600	600
Type of protection	--	IP 54	IP 54
Speed	1/min	Phaseless	Phaseless
- Sweeping aggregates and blower			
Type	--	DC permanent solenoid motor	DC permanent solenoid motor
Type	--	B14	B14
Voltage	V	24	24
Rated current	A	33	33
Rated power (mechanical)	W	600	600
Type of protection	--	IP 20	IP 20
Speed	1/min	3600	3600
Battery			
Type	--	--	6V 6iV 180 DTP
Quantity	--	--	4
Capacity	Ah	--	180
Charging time for fully discharged battery	h	--	10...15
Operating time after frequent charging	h	--	ca. 2,5
Charger			
Mains voltage	V~	--	230
Output voltage	V	--	24
Output current	A	--	27
Tyres			
Size, rear	--	4.00-8 6PR	4.00-8 6PR
Air pressure, rear	bar	4,25	4,25
Brake			
Operating brake, emergency brake	--	electronic	electronic
Filter and vacuum system			
Filter system	m ²	TACT	TACT
Category of use – filter for non-hazardous dust	--	M	M

		KM 90/60 R Bp Adv	KM 90/60 R Bp Pack Adv (Edition)
Nominal vacuum, suction system	mbar	8	8
Nominal volume flow, suction system	l/s	41	41
Working conditions			
Temperature	°C	+5...+45	+5...+45
Air humidity, non-condensing	%	0 - 90	0 - 90
Noise emission			
Sound pressure level (EN 60704-1)	dB(A)	69	69
Uncertainty K_{pA}	dB(A)	2	2
Guaranteed sound power level (2000/14/EC)	dB(A)	87	87
Machine vibrations			
Hand-arm vibration value	m/s ²	< 2,5	< 2,5
Uncertainty K	m/s ²	0,2	0,2
Seating	m/s ²	0,5	0,5

EU Declaration of Conformity

We hereby declare that the machine described below complies with the relevant basic safety and health requirements of the EU Directives, both in its basic design and construction as well as in the version put into circulation by us. This declaration shall cease to be valid if the machine is modified without our prior approval.

Product: Vacuum sweeper
Type: 1.047-xxx

Relevant EU Directives
2006/42/EC (+2009/127/EC)
2014/30/EU
2000/14/EC
2014/53/EU (TCU)

Applied harmonized standards
EN 60335-1
EN 60335-2-29
EN 60335-2-72
EN 55012:2010
EN 55014-1:2017
EN 55014-2
EN 61000-3-2: 2014
EN 61000-3-3: 2013
EN 61000-6-2: 2005 (TCU)
EN 300 328 V2.1.1
EN 300 330 V2.1.1
EN 300 440 V2.1.1

Applied national standards
Applied national standards

Applied conformity evaluation method
2000/14/EC: Appendix V
Sound power level dB(A)
Measured: 85
Guaranteed: 87

The signatories act on behalf of and with the authority of the company management.

H. Jenner

Chairman of the Board of Management

S. Reiser

Director Regulatory Affairs & Certification

Documentation supervisor:
S. Reiser

Alfred Kärcher SE & Co. KG
Alfred-Kärcher-Straße 28-40
71364 Winnenden (Germany)
Tel.: +49 7195 14-0
Fax: +49 7195 14-2212

Winnenden, 2018/10/01

Accessories

Side brushes, standard	6.906-132.0
For cleaning of indoor and outdoor areas.	
Hard side-brushes	6.905-625.0
For removing stubborn dirt in the external area; resistant to moisture.	
Side-brushes, soft	6.905-626.0
Especially for sweeping fine dust on even floors.	
Roller brush, standard	4.762-430.0
Resistant of wear and moisture. Universal bristles for inside and outside cleaning.	
Roller-brush, soft	4.762-442.0
With natural bristles especially for fine dust sweeping on smooth indoor floors. Not resistant to wetness; not for abrasive surfaces.	
Roller-brush, hard	4.762-443.0
For removing stubborn dirt in the external area; resistant to moisture.	
Flat-fold filter (dust filter)	6.907-352.0
Roller brush, antistatic	4.762-441.0
Upgrade kit solid rubber tyres	2.641-129.0
Upgrade kit side brush left	2.642-693.0
Attachment set: over-all lamp	2.642-989.0
Upgrade kit double TACT	2.643-176.0
Set holder brush homebase	4.035-523.0
Set coarse dirt pliers homebase	4.035-524.0