

KÄRCHER

makes a difference

B 80

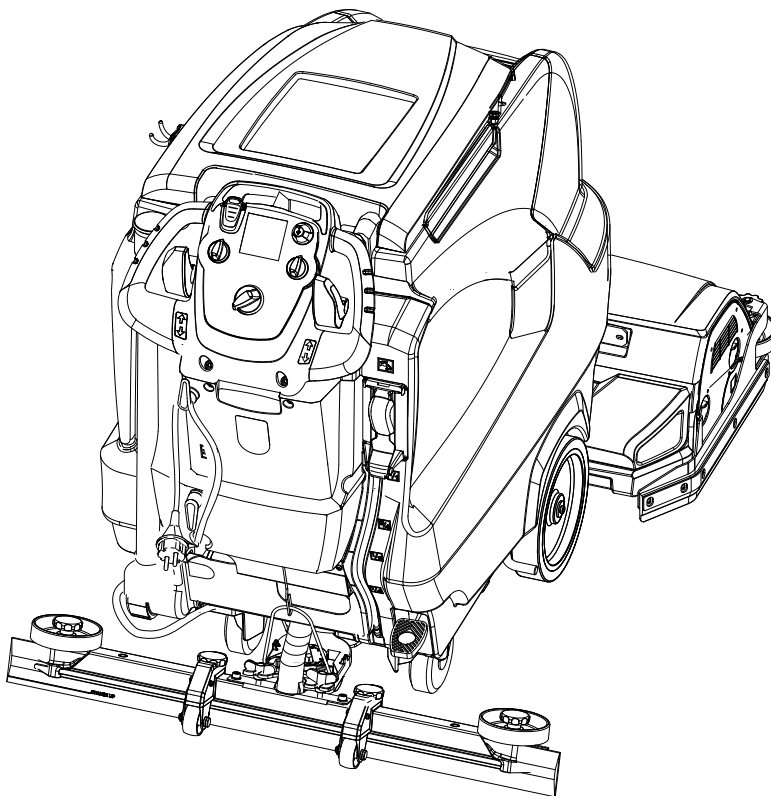

Deutsch	3
English	14
Français	25
Italiano	36
Nederlands	47
Español	58
Português	69
Dansk	80
Norsk	90
Svenska	101
Suomi	112
Ελληνικά	123
Türkçe	134
Русский	145
Magyar	157
Čeština	168
Slovenščina	179
Polski	190
Românește	201
Slovenčina	212
Hrvatski	223
Srpski	234
Български	245
Eesti	256
Latviešu	267
Lietuviškai	278
Українська	289



Register
your product
www.kaercher.com/welcome



EAC



59784980 09/21



B 80 W Bp

B 80 W Bp Dose

B 80 W Bp Fleet

B 80 W Bp Dose Fleet

B 80 W Bp Dose Colruyt

  Please read and comply with these original instructions prior to the initial operation of your appliance and store them for later use or subsequent owners.

Contents

Safety instructions	EN	1
Function	EN	1
Proper use	EN	1
Environmental protection	EN	2
Warranty	EN	2
Operating and Functional Elements	EN	3
Before Startup	EN	4
Operation	EN	5
Shutting Down the Appliance	EN	6
Grey Intelligent Key	EN	6
Transport	EN	6
Storage	EN	6
Care and maintenance	EN	7
Frost protection	EN	9
Faults	EN	9
Accessories	EN	10
Technical specifications	EN	11
EU Declaration of Conformity	EN	12
Declaration of Conformity	EN	12
Accessories and Spare Parts	EN	12

Safety instructions

Before using the appliance for the first time, read and observe these operating instructions and the accompanying brochure: Safety information for brush cleaning units and spray-extraction units, No. 5.956-251.0.

Do not use the appliance on inclines.

The appliance may only be operated when the hood and all lids are closed.

Remove the Intelligent Key (emergency stop) to take all functions out of operation immediately.

Safety Devices

Safety devices serve to protect the user and must not be rendered in operational or their functions bypassed.

Drive lever

If the drive lever is released, the travel drive and the brush drive shuts off.

Emergency stop buttons (only for B 80 W Bp Dose Colruyt)

Press emergency-stop switch to immediately switch off all functions of the machine.

Function

The scrubber vacuum is used for wet cleaning or polishing of level floors.

- You can adjust the machine to suit the cleaning task by modifying the settings for water quantity, contact pressure of the brushes, detergent quantity and driving speed.
- The appliance is equipped with a fresh water and a wastewater reservoir (80 litres each). These allow an effective cleaning with a long usage life.
- Depending on the selected cleaning head, the working width of the B 80 is between 650 mm and 750 mm.
- This appliance is equipped with a travel drive, drive motor and brush drive that are driven by four batteries.
- The charger is already installed. Batteries can be selected according to the configuration (see Chapter "Recommended batteries")

Note:

The appliance can be equipped with various accessories depending on the cleaning task.

Please request our catalogue or visit us on the Internet at www.kaercher.com.

Proper use

Use this appliance only as directed in these operating instructions.

- This appliance is suited for the commercial use, e.g. in hotels, schools, hospitals, factories, shops, offices, and rental companies.
- The appliance may only be used for the cleaning of hard surfaces that are not sensitive to moisture and polishing operations.
- The appliance is not suited for the cleaning of frozen grounds (e.g. in cold stores).
- The appliance may only be equipped with original accessories and spare parts.
- The appliance is not suited for the use in potentially explosive environments.
- The machine should not be used to suck in inflammable gases, undiluted acids or solvents.

This includes petrol, thinning agents or hot oil that can form an explosive mixture when it comes in contact with sucked air. Do not use acetone, undiluted acids and solvents as they are aggressive towards the materials from which the appliance is made.

The appliance has been developed for cleaning floors - floors inside rooms and roofed areas. With respect to other applications the usage of alternative brushes must be checked.

- The device is not intended for use by persons (including children) with reduced physical, sensory or mental capabilities, or lack of experience or knowledge
- The device is not intended for use by persons with restricted physical, senso-



ry or mental abilities or those lacking in experience and / or lacking in knowledge, unless they have been given supervision or instruction concerning use of the appliance by a person responsible for their safety.

- Children should be supervised to ensure that they do not play with the appliance.

WARNING

Do not use the appliance on inclines.

Environmental protection

	The packaging materials are recyclable. Please do not throw packaging in the domestic waste but pass it on for recycling.
	Old units contain valuable recyclable materials. Batteries, oil and similar substances may not be released into the environment. Therefore please dispose of old units through suitable collection systems.

Notes about the ingredients (REACH)

You will find current information about the ingredients at:

www.kaercher.com/REACH

For guidance regarding safe disposal of batteries, refer to your local council or waste governing body.

The battery must be removed from the appliance before it is scrapped.

The battery must be disposed of safely.

Warranty

The warranty terms published by our competent sales company are applicable in each country. We will repair potential failures of your accessory within the warranty period free of charge, provided that such failure is caused by faulty material or defects in fabrication. In the event of a warranty claim please contact your dealer or the nearest authorized Customer Service center. Please submit the proof of purchase.

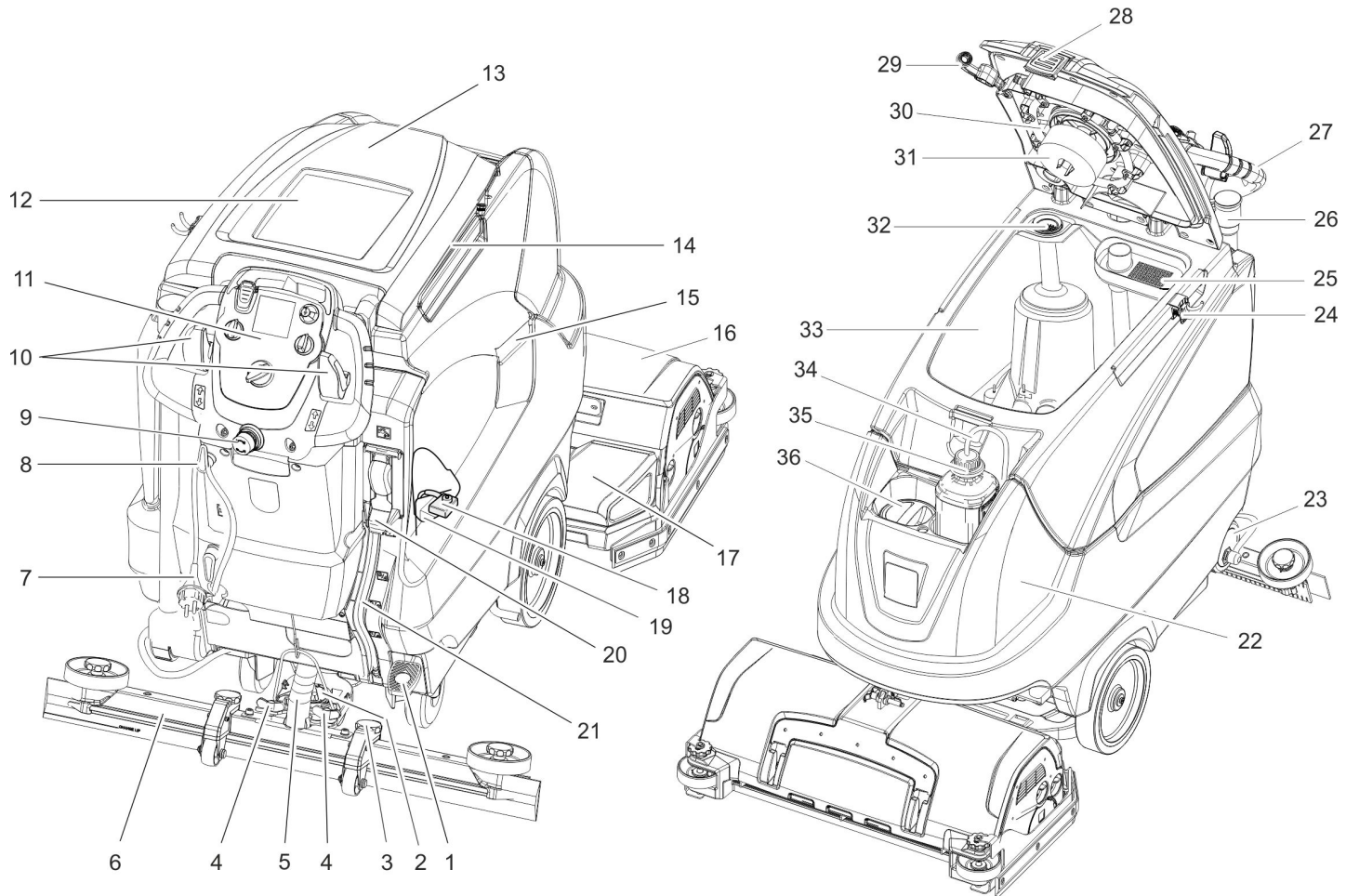

Illustration of scrubbing vacuum

- | | |
|---|---|
| <ol style="list-style-type: none"> 1 Parking brake 2 Rotary handle to incline the vacuum bar 3 Height adjustment of suction bar 4 Wing nuts for fastening the vacuum bar 5 Suction hose 6 Vacuum bar * 7 Connecting cable for charger 8 Storage compartment for mains cable 9 Emergency stop buttons (only for B 80 W Bp Dose Colruyt) 10 Driving lever 11 Operator console 12 Storage surface for cleaning set "Home base box" 13 Cover waste water tank 14 Holding rail for home base 15 Recessed grip 16 Cleaning head (illustration is symbolic) *
Brush rollers (BR model) Disk brushes (BD model) * 17 Waste container (only BR) 18 Battery pole fuse 19 Battery * 20 Automatic fill of fresh water reservoir (option) 21 Fresh water level display 22 Fresh water tank 23 Lock of the fresh water reservoir with filter 24 Homebase - accessories holder * 25 Coarse dirt sieve 26 Drain hose for wastewater with dosing unit 27 Push handle 28 Lock of waste water tank | <ol style="list-style-type: none"> 29 Flexible lock of rinsing system (option) 30 Wastewater reservoir rinsing system (option) 31 Float 32 Fluff filter 33 Waste water tank 34 Suction hose for detergent (only DOSE model) 35 Detergent bottle (only DOSE model) 36 Fresh water reservoir filler neck <p><i>* not included in the delivery</i></p> |
|---|---|

Colour coding

- The operating elements for the cleaning process are yellow.
- The controls for the maintenance and service are light gray.

Operator console

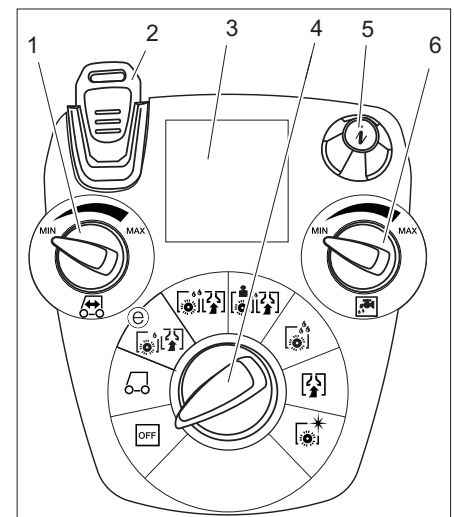

- 1 Rotating button for drive speed
- 2 Intelligent Key
yellow - operator
grey - supervisor
- 3 Display
- 4 Program selection switch
- 5 Info button
- 6 Water quantity regulator

Program selection switch

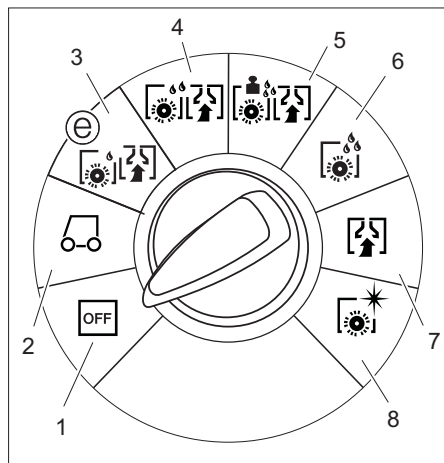

- 1 **OFF**
Device is switched off
- 2 **Transport mode**
Driving to the Place of Use.
- 3 **Eco mode**
Wet clean the floor (with reduced brush speed) and vacuum up wastewater (with reduced suction).
- 4 **Normal mode**
Wet clean the floor and vacuum up dirt water.
- 5 **Increased brush contact pressure**
Wet clean the floor (with increased brush contact pressure) and vacuum up dirt water.
- 6 **Intense mode**
Wet clean the floor and allow the detergent to react.
- 7 **Vacuum mode**
Suck in the dirt fleet.
- 8 **Polishing mode**
Polishing the floor without the application of liquid.

Before Startup

Installing the Brushes

BD model

The disc brush must be installed before the initial operation (see "Maintenance work").

BR model

The brushes are mounted.

Install batteries

Install the batteries (see "Care and Maintenance/Install and connect batteries").

Setting the charging marker line

Prior to the initial startup, following a service reset or when switching to another battery type, you must adjust the charging marker line.

- ➔ Use the Grey Intelligent Key.
- ➔ Setting the charging marker line (see Chapter "Grey Intelligent Key/Setting the charging marker line").

Using batteries made by other manufacturers

We recommend using our batteries as described in chapter "Care and Maintenance/Recommended batteries".

Note:

When using other batteries (e.g. batteries from other manufacturers), the total discharge protection level for the respective battery must be reset by the Kärcher after-sales service.

Charging battery

Note:

The device is equipped with a safety mechanism to prevent total discharge, i.e. when the permissible minimum capacity is reached, the brush motor and the turbine are switched off.

- ➔ Drive the machine directly to the charging station; avoid any steep gradients in the process.

⚠ DANGER

Danger of injury due to electric shock. Observe the mains voltage and fuse protection on the type plate of the device.

Only use the charger in dry rooms with sufficient ventilation!

Charging process

- Average charging time is approx. 10-15 hours.
- The built-in charger has electronic controls and is suitable for all recommended batteries; it automatically switches off the charging process.
- The built-in battery is shown on the display during the charging process. If this is not the case, the charging marker line must be selected (see "Setting the charging marker line").
- The appliance must not be used during the charging process.
- ➔ Insert the plug of the connecting cable into the socket. The charging process will start.
- Note:** The selected battery will be displayed during charging.
- ➔ Charge until the display shows a full charge.

Notes on initial charge

With the initial charge, the control will not yet be able to detect which battery type has been installed. Keep charging the batteries until the display shows a full charge

Low maintenance batteries (wet batteries)

⚠ WARNING

Danger of causticization!

- *Adding water to the battery in its discharged state can cause the acid to leak.*
- *Use safety glasses while handling battery acid and follow the safety instructions to avoid personal injury or damage to clothes.*
- *Should the acid spray on to the skin or clothes, rinse immediately with lots of water.*

ATTENTION

Risk of damage!

- *Use only distilled or desalinated water (EN 50272-T3) for filling the battery.*
- *Do not add any substances (so-called performance improving agents), else warranty claims will not be entertained.*
- *Replace batteries with the same battery type only. Otherwise the charging characteristics must be readjusted by the after-sales service.*

Installing the Vacuum Bar

- ➔ Insert the vacuum bar into the vacuum bar suspension in such a manner that the profiled sheet is positioned above the suspension.
- ➔ Tighten the wing nuts.

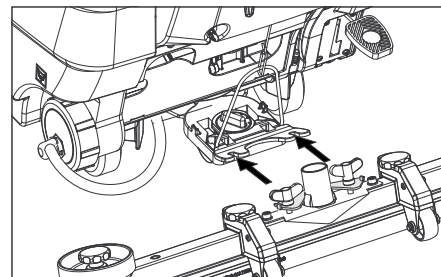

- ➔ Insert the suction hose.

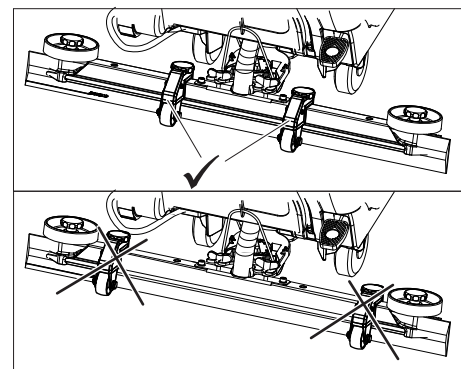

- ➔ Check if the height adjustment is mounted on the inside of the vacuum bar. When the height adjustment is mounted on the outside, the vacuum bar gets caught at the bottom of the appliance.

Unloading

⚠ DANGER

Risk of injury. Pull the Intelligent Key to take all functions out of operation immediately.

- ➔ Insert batteries and connect (see "Before Start-up").
- ➔ Place long lateral boards of the packaging as a ramp next to the pallet.

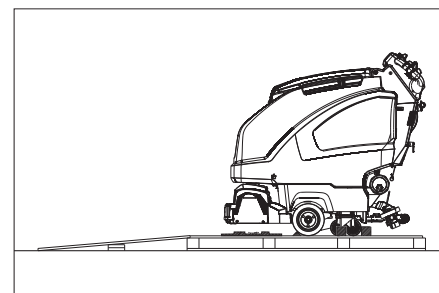

- ➔ Fix the ramp on the pallet with nails.
- ➔ Place short boards as a support underneath the ramp.
- ➔ Remove the wooden bars in front of the wheels.

- Plug in the Intelligent Key.
- Turn the program selection switch to transport mode.
- Press the driving lever and slowly move the machine down from the ramp.
- Remove the Intelligent Key.

Operation

⚠ DANGER

In dangerous situations, release the drive lever.

Parking brake

- Loosen the parking brake; for that press the pedal downward and move it to the left. Then let the pedal go upward.
- Activate immobilising brake. Press the pedal downwards and move it to the right to lock it.

Driving

Note:

The device is designed and built in such a way that the cleaning head protrudes towards the right. This enables working in a comfortable way close to the edges.

- Plug in the Intelligent Key.
- Preselect the speed on the drive speed rotary knob.
- Turn the programme selection switch to transport mode.
- Release parking brake.
- Drive the machine.
 - Forwards: Press the driving lever to the front.
 - Backward: Press the driving lever to the rear.

Note:

The device will only move if the drive lever is moved by 15°.

- Stop the machine: Release driving lever.

Filling in detergents

Fresh water

- Open the lock of the fresh water reservoir.
- Fill fresh water (maximum 60 °C) until the lower edge of the filling nozzle.
- Close the lock of the fresh water reservoir.

With automatic fill of fresh water reservoir (option)

- Connect the hose to the automatic filling system and open the water supply (max. 60 °C, max. 5 bars).
- Monitor the appliance - the automatic filling system will interrupt the water supply when the tank is full.
- Shut off the water supply and disconnect the hose from the appliance.

Detergent

⚠ WARNING

Risk of damage. Only use the recommended detergents. With other detergents, the operator bears the increased risk regarding the operational safety and danger of accident.

Only use detergents that are free from solvents, hydrochloric acid and hydrofluoric acid.

Follow the safety instructions for using detergents.

Note:

Do not use highly foaming detergents.

Recommended detergents:

Application	Detergent
Routine cleaning of all water resistant floors	RM 746 RM 780
Routine cleaning of glossy surfaces (e.g. granite)	RM 755 es
Routine cleaning and basic cleaning of industrial floors	RM 69 ASF
Routine cleaning and basic cleaning of fine stoneware tiles	RM 753
Routine cleaning of tiles in sanitary areas	RM 751
Cleaning and disinfection in sanitary areas	RM 732
Removal of coating from all alkali-resistant floors (e.g. PVC)	RM 752
Removal of coating from linoleum floors	RM 754

Appliance with dosing equipment DOSE (option)

Detergent is added to the fresh water on the way to the cleaning head with the help of a dosaging device.

Note:

The dosing unit can be used to add 3% detergent at maximum. With higher dosage the detergent must be put into the fresh water tank.

- Place the detergent bottle into the holder.
- Close the bottle lid.
- Insert the suction hose of the dosaging equipment into the bottle.

Note:

If the fresh water tank is empty, then the function of adding detergent gets deactivated. The cleaning head continues to work without the addition of any liquid.

Detergent addition is also stopped when the detergent canister is empty.

Models without dosing equipment

- Add the detergent to the fresh water reservoir.

Setting the water quantity

- Adjust the water quantity using the regulating button according to the dirt on the floor covering.

Note:

Carry out initial cleaning attempts with low water volume. Increase water volume step-by-step until the desired cleaning result is achieved.

The detergent pump of the dosing equipment does not start working until a minimum water volume is present.

Setting the Vacuum Bar

Oblique position

To improve the vacuuming result on tiled floors the vacuum bar can be turned to an oblique position of up to 5°.

- Loosen the wing nuts.
- Turn the vacuum bar.

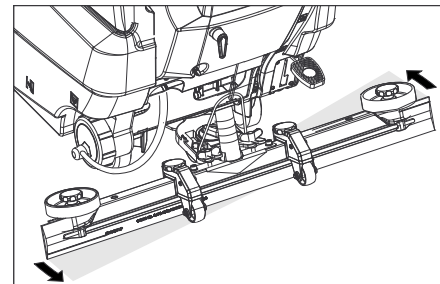

- Tighten the wing screws.

Inclination

If the vacuum result is unsatisfactory the inclination of the straight vacuum bar can be modified.

- Adjust the rotary handle to incline the suction bar.

Setting the parameters

With yellow Intelligent Key

Parameters for the different cleaning programmes are preset in the appliance. Depending on the authorisation of the yellow Intelligent Key, individual parameters can be changed.

The modification of the parameters is only valid until another cleaning programme is selected via the programme selection switch.

If you wish to permanently change the parameters, you must use a grey Intelligent Key. This adjustment procedure is described in the section "Grey Intelligent Key".

Note:

Almost all displayed text regarding parameter adjustment is self-explanatory. The only exception is the parameter FACT:

- Fine Clean: Lower brush speed for removing the grey film on fine stone floors.
- Whisper Clean: Medium brush speed for regular cleaning with reduced noise level.
- Power Clean: High brush speed for polishing, crystallising and sweeping.
- Turn the program selection switch to the desired cleaning program.
- Turn the info button until the desired parameter is displayed.
- Press Info button - the set value blinks.
- Set the desired value by turning the info button.
- Confirm the changed setting by pressing the Info button or wait till the set value is automatically accepted after 10 seconds.

Cleaning

ATTENTION

Risk of damage to the floor covering. Do not operate the appliance on the spot.

- Turn the program selection switch to the desired cleaning program.

Lower the cleaning head

- The appliance controls the lowering and raising of the cleaning head automatically, depending on the selected programme mode. The brush motor also runs and stops automatically.

Note:

The brush motor comes to a halt when the machine stops and when there is overload.

Lower the vacuum bar

- The appliance controls the lowering and raising of the suction bar automatically, depending on the selected programme mode.

Note:

For cleaning tiled floors, adjust the straight suction bar in such a way that cleaning is not done at an angle of 90 degrees to the joints.

The inclined position and the inclination of the suction bar can be adjusted to achieve better suction results (see "Adjusting the suction bar").

If the wastewater reservoir is full, the floater will close the suction opening and the suction turbine will run at a higher speed. If this is the case, shut the vacuum off and drive to empty the wastewater reservoir.

Shutting Down the Appliance

- Close the regulatory button for setting the water quantity.
- Release driving lever.
- Set the program selection switch to suction or vacuuming.
- Briefly drive forward and suck of the remaining water.
- Remove the Intelligent Key.
- Charge battery, if required.

Drain off dirt water

⚠ WARNING

Please observe the local provisions regarding the wastewater treatment.

- Take the water discharge hose from the support and lower above a suited collection device.

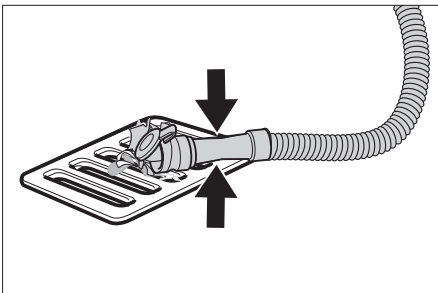

- Crush or bend the dosing equipment.
- Open the lid of the dosing equipment.
- Drain off the dirt water - regulate the water quantity by pressing or bending.

- Rinse the waste water tank with clean water or with the rinsing system for the waste water tank (option).

Drain off clean water

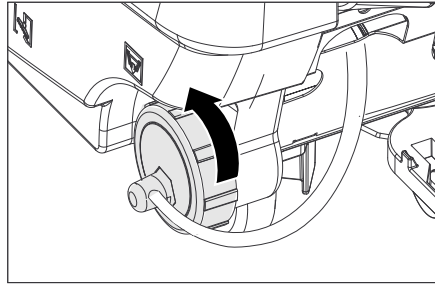

- Loosen the lid for emptying the fresh water - do not remove it fully. Drain water.
- To rinse the fresh water reservoir, remove the cover completely and remove the fresh water filter.

Grey Intelligent Key

- Plug in the Intelligent Key.
- Select the desired function by turning the Info button.

The different functions are described in the following.

Key menu >>

In this menu item, the authorisations for the yellow Intelligent Keys are released.

- Press the info button while "Key menu >>" is displayed.
- Remove the grey Intelligent Key and insert the yellow Intelligent Key to be programmed.
- Select the desired menu item to be modified by turning the Info button.
- Press Info button.
- Adjust the menu item by turning the Info button.
- Confirm the setting by pressing the menu item.
- Select the next menu item to be modified by turning the Info button.
- To save the authorisations, retrieve the menu "Save settings" by turning the info button and pressing it.
- To exit, retrieve the menu "Exit menu" by turning the info button and pressing it.

Cleaning App >>

Parameters that are adjusted with the grey Intelligent Key, are kept until another setting is selected.

- Turn the program selection switch to the desired cleaning program.
- Turn the info button until "Cleaning App >>" is displayed.
- Press the info button - the first adjustable parameter is displayed.
- Press Info button - the set value blinks.
- Set the desired value by turning the info button.
- Confirm the changed setting by pressing the Info button or wait till the set value is automatically accepted after 10 seconds.
- Select the next parameter by turning the Info button.

- After all desired parameters have been modified, turn the info button until "Exit menu" is displayed.
- Press the info button - you will exit the menu.

Setting the language

- Press Info button - the set value blinks.
- Set the desired language by turning the info button.
- Confirm the changed setting by pressing the Info button or wait till the set value is automatically accepted after 10 seconds.

Brush trailing

Adjust the trailing time of the brushes.

- Same adjustment as "Set language".

Setting the charging marker line

- Turn the info button until the function "Battery menu" is displayed.
- Press the info button - select the charging marker line according to the built-in batteries.

Note: Setting the charging marker line should be discussed with Kärcher customer service. This applies especially if the battery is not listed in the menu.

- Confirm the changed setting by pressing the Info button or wait till the set value is automatically accepted after 10 seconds.

LOAD DEFAULT

Recreate the basic settings.

Transport

⚠ DANGER

Risk of injury! When loading or unloading the machine, it may only be operated on gradients up to the maximum value (see "Technical Specifications"). Drive slowly.

⚠ CAUTION

Risk of personal injury or damage! Mind the weight of the appliance during transport.

- Remove the brush to avoid damage to the brushes.
- Activate parking brake.

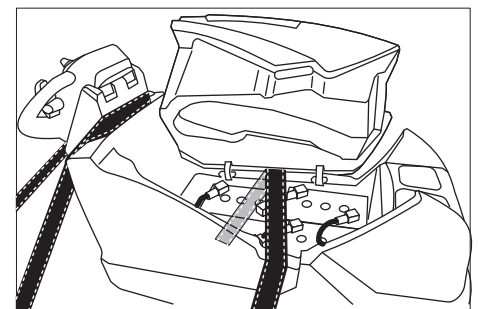

- When transporting in vehicles, secure the appliance according to the guidelines from slipping and tipping over.

Storage

⚠ CAUTION

Risk of personal injury or damage! Consider the weight of the appliance when storing it.

This appliance must only be stored in interior rooms.

Care and maintenance

⚠ DANGER

Risk of injury! Before working on the appliance, remove the Intelligent Key and the mains plug of the charger.

- Drain and dispose of the dirt water and the residual fresh water.

Maintenance schedule

Maintenance intervals

- Perform the maintenance task shown on the display.

Vacuum bar Clean the filter
Water filter Clean the filter
Suction lips opinion
Turbine Clean filter
Brush Clean or replace

- Press the Info Button, the display will be reset. The display will be shown again at certain predefined time intervals.

After each operation

ATTENTION

Risk of damage. Do not sluice the appliance with water and do not use aggressive detergents.

- Drain off dirt water.
- Clean protective turbine strainer.
- Rinse the waste water tank with clean water or with the rinsing system for the waste water tank (option).
- Remove the coarse dirt sieve from the waste water tank and clean it.
- Clean the outside of the appliance with a damp cloth which has been soaked in mild detergent.
- Check the fluff filter, clean if required.
- Only BR model: Remove bulk waste container and empty it.
- Only BR model: Clean water distributor channel (see section „Maintenance work“).
- Clean the vacuum lips and the wiping lips, check for wear and replace if required.
- Check the brushes for wear, replace if required.
- Press the lock of the waste water tank in and close the cover of the waste water tank so that a gap remains open to facilitate drying.

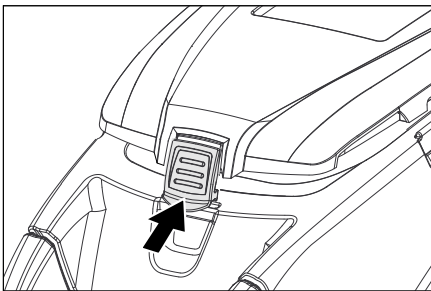

- Charge the battery:
If the charging state of the battery is under 50%, charge the battery fully and without interruption.
If the charging state of the battery is over 50%, only recharge the battery if the entire operation duration will be required when next used.

Weekly

- When used regularly, charge the battery fully and without interruption at least once a week.

Monthly

- Check battery poles for oxidation, brush off if necessary. Ensure that the connection cable sits firmly.
- Clean the seals between waste water tank and cover and check for tightness, replace if required.
- Check the acid density of the cells if the batteries are not maintenance-free batteries.
- Clean the brush tunnel (only BR model).
- For long periods of disuse, only turn the device off when the battery is fully charged. Fully recharge the battery at least every month.

Yearly

- Have the prescribed inspection carried out by the customer service.

Maintenance Works

Waste water tank rinsing system (option)

- Take the dirt water discharge hose from the support and lower above a suited collection device.
- Open the lid of the dosing equipment.
- Open the cover of the waste water tank.
- Pull the flexible lock off of the rinsing system.
- Connect the water hose to the rinsing system.

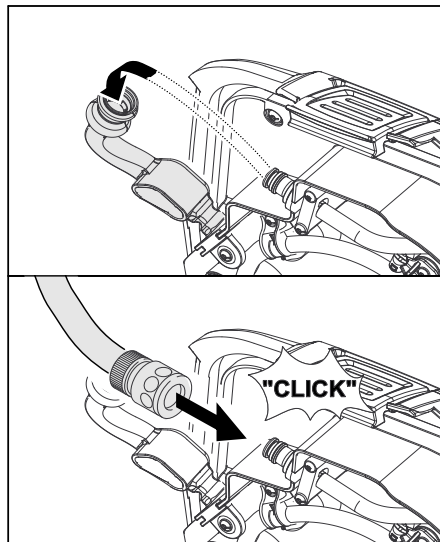

- Close the cover of the wastewater reservoir until it rests on the flexible lock.
- Open the water supply and rinse the wastewater reservoir for about 30 seconds.
Repeat the rinsing process 2 to 3 times.
- Shut off the water supply and disconnect the hose from the appliance.

Cleaning the protective turbine strainer

- Open the cover of the waste water tank.

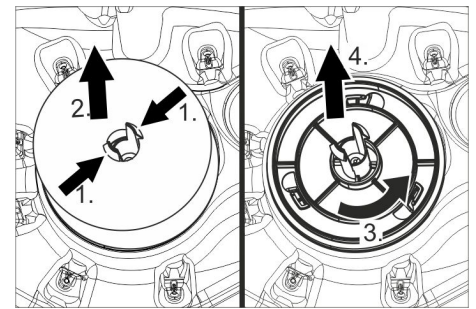

- Squeeze the locking hooks.
- Pull off the float.
- Turn the protective turbine strainer in a counter-clockwise direction.
- Remove protective turbine strainer.
- Rinse dirt off the protective turbine strainer with water.
- Reattach protective turbine strainer.
- Attach float.

Replace or turn vacuum lips

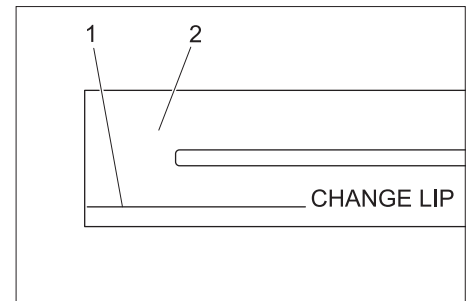

- 1 Wear indicator
- 2 Vacuum lip

The vacuum lips must be replaced or reversed if they are worn down to the wear indicator.

- Remove the vacuum bar.
- Unscrew the star grips.

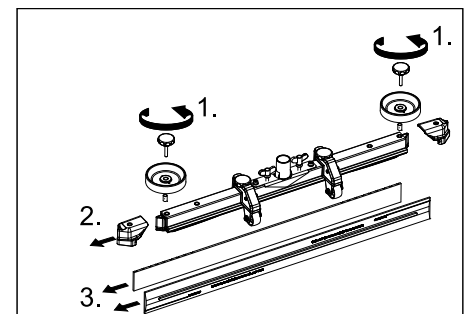

- Remove the plastic parts.
- Remove the vacuum lips.
- Insert new or reversed vacuum lips.
- Insert the plastic parts.
- Screw in and tighten the star grips.

Clean water distribution channel

- Remove the rubber strip and clean the channel with a cloth. After cleaning, replace the rubber strip evenly.

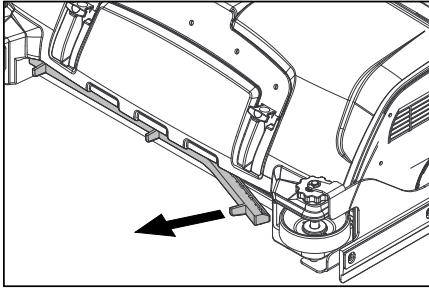

Replacing the brush rollers

- Loosen the lock of the wiper flap.
 - Push the bearing lid down and remove.
 - Pull out the brush rollers.
- Note:** The brush rollers must be replaced when the bristle length has reached 10 mm.

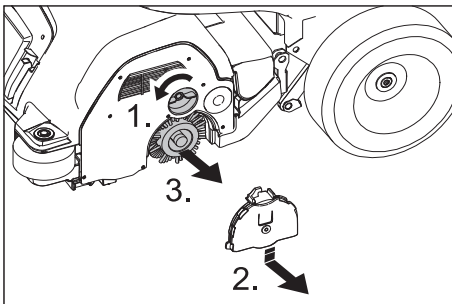

- Insert a new brush roller.
- Reassemble the bearing lid in the reverse sequence.
- Repeat process on the opposite side.

Replacing the disk brushes

- Press the pedal for changing the brushes downward beyond its resistance.

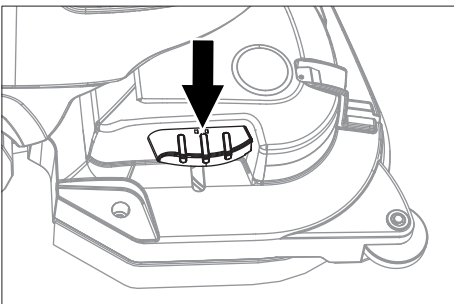

- Pull the disc brush out of the side below the cleaning head.
- Hold the new disc brush under the cleaning head, push upward and lock.

Install cleaning head

- Push the appliance forward about 2 m so that the steering rollers point toward the rear.
- Press the pedal for lowering the cleaning head downwards slightly and then move it to the left. This unlocks the pedal. Release the pedal slowly upwards. The lift arm of the cleaning head will be lowered.

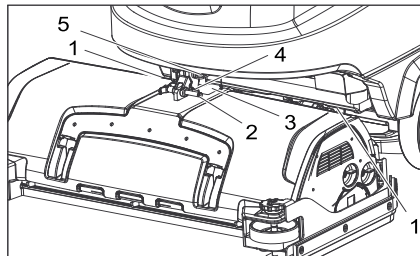

- 1 Spring element
- 2 Locking pin
- 3 Terminal strip cover
- 4 Lock of safety pin
- 5 Excenter lever

- Remove the terminal strip cover.
- Place the cleaning head halfway in front of the appliance.
- Connect the mains supply cable of the cleaning head to the appliance.
- Attach the terminal strip cover.
- Connect the hose couplers on the cleaning head to the hose on the appliance.

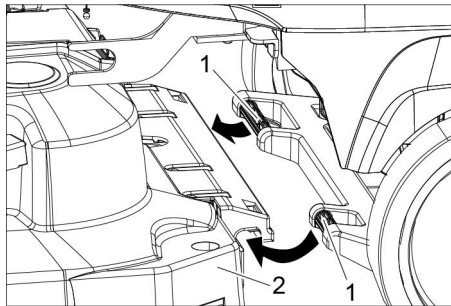

- 1 Push handle
- 2 Cleaning head

- Insert the push bow into the cleaning head intake.

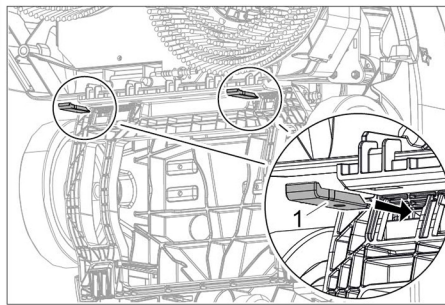

- 1 Safety splint

- Insert the locking pins from below into the mount of the cleaning head.

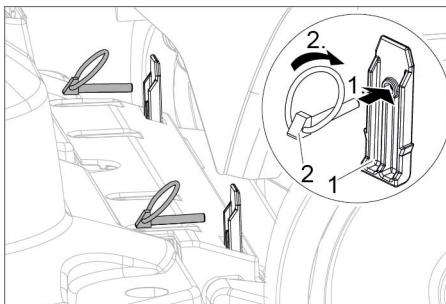

- 1 Safety splint
- 2 Linch pin

- Insert the linch pin through the locking pins and fold the locking rings forward.

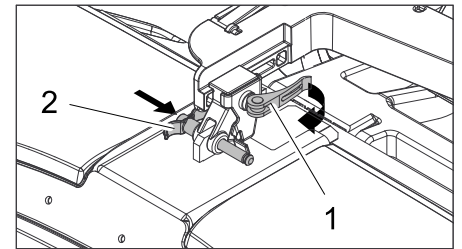

- 1 Excenter lever
- 2 Locking pin

- Open the excenter lever of the slideable intake on the lift arm.
- Press the cleaning head all the way against the push handle.
 - Note:** The less play the cleaning head has after being installed, the less vibration will occur during cleaning.
- Move the intake and insert the safety pin and lock it into place.
- Close the excenter lever.
- Swivel the water reservoir all the way down, check the lock.

Dismantling the cleaning head

The removal will take place in the opposite order of the installation.

⚠ CAUTION

When the cleaning head is removed, the stability of the appliance can be compromised; ensure a safe stance.

Possibly support the rear to prevent tipping.

Batteries

Please observe the following warning notes when handling batteries:

	Observe the directions on the battery, in the instructions for use and in the vehicle operating instructions
	Wear eye protection
	Keep children away from acid and batteries
	Danger of explosion
	Fire, sparks, naked flames and smoking must be strictly avoided
	Danger of chemical burns
	First aid
	Warning note
	Disposal
	Do not throw the battery into the regular waste

like on the battery, i.e. on the terminal poles and cell connectors.

Risk of injury. Ensure that wounds never come into contact with lead. Always clean your hands after having worked with batteries.

Recommended batteries, B 80

Replacement battery typ; Inventus (25.6V 80Ah lithium).

Order No.	Description	
6.654-119.0 ¹⁾	240 Ah - maintenance-free	6 V**
6.654-124.0 ²⁾	180 Ah - maintenance-free	6 V**
6.654-242.0 ³⁾	170 Ah - maintenance-free	6 V**
6.654-086.0 ⁴⁾	180 Ah, - low maintenance	6 V**

** Appliance requires 4 batteries

¹⁾ Complete set (24 V/240 Ah) incl. connecting cable, order no. 4.035-393.0

²⁾ Complete set (24 V/180 Ah) incl. connecting cable, order no. 4.035-387.0

³⁾ Complete set (24 V/170 Ah) incl. connecting cable, order no. 4.035-388.0

⁴⁾ Complete set (24 V/180 Ah) incl. connecting cable, order no. 4.035-440.0

Insert batteries and connect

⚠ CAUTION

When the batteries are installed and removed, the stability of the appliance can be compromised; ensure a safe stance.

→ Push the appliance forward about 2 m so that the steering rollers point toward the rear.

→ Hold the wastewater reservoir by the handle recess and swivel the reservoir upwards toward the side.

→ Insert all four batteries into the trough. The 240 Ah batteries are seated flush in the battery intake, no holding blocks are required.

For the 170 Ah and 180 Ah batteries, 2 holding blocks must be installed in the front and one in the right rear on the floor. In addition to that, a foam strip is

inserted on the rear left.

ATTENTION

Pay attention to correct poles.

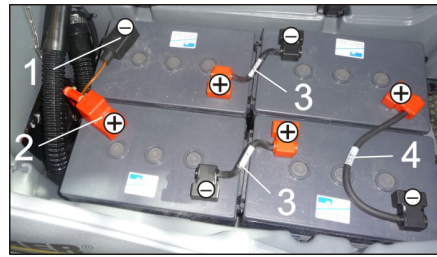

- 1 Connecting cable of battery (-)
- 2 Connecting cable of battery (+)
- 3 short connecting cable
- 4 long connecting cable

→ Connect the batteries as shown, use the included connecting cables for this.

→ Connect the connection cable to the free battery poles (+) and (-).

Note: The red connecting cable has an increased protective layer. In order for the tank not to touch when close, the connecting cable must be connected as shown in the illustration.

→ Tilt the wastewater tank down.

ATTENTION

Ensure that correct polarity of battery cables is observed when connecting/disconnecting battery (+/- as marked on the battery terminals).

ATTENTION

When disconnecting battery, ensure appliance is turned off and disconnected from mains power supply.

ATTENTION

Remove battery cables one at a time, ensuring the cable terminals do not touch one another.

ATTENTION

Charge the battery before commissioning the machine.

Removing the batteries

⚠ CAUTION

Risk of damage due to tipping appliance; remove batteries only if the appliance is equipped with a cleaning head.

→ Remove the Intelligent Key.

→ Push the appliance forward about 2 m so that the steering rollers point toward the rear.

→ Hold the wastewater reservoir by the handle recess and swivel the reservoir upwards toward the side.

→ Clamp off the minus pole of the battery.

→ Clamp off the remaining cables from the battery.

→ Remove the support blocks.

→ Remove the batteries.

⚠ CAUTION

When the cleaning head is removed, the stability of the appliance can be compromised; ensure a safe stance.

Possibly support the rear to prevent tipping.

⚠ CAUTION

When the batteries are installed and removed, the stability of the appliance can be compromised; ensure a safe stance.

→ Dispose of the used batteries according to the local provisions.

Maintenance contract

To ensure a reliable operation of the appliance maintenance contracts can be concluded with the competent Kärcher sales office.

Frost protection

In case of danger of frost:

→ Empty the fresh and waste water tank.

→ Store the appliance in a frost-protected room.

Faults

⚠ DANGER

Risk of injury! Before working on the appliance, remove the Intelligent Key and the mains plug of the charger.

→ Drain and dispose of the dirt water and the residual fresh water.

Faults with display

Display	Remedy
ERR_I_BÜRSTE_049	Check if foreign matters block the brushes; remove foreign matter if required.
ERR_I_TURB_050	Check suction turbine for contamination and clean it if necessary.
ERR_U_BATT_001	Check battery; charge it if required.

If the display shows different error messages or if the error cannot be remediated:

→ Remove the Intelligent Key.

→ Wait for 10 seconds.

→ Plug in the Intelligent Key.

→ If the fault recurs, call customer service.

Faults without display on the console

Fault	Remedy
Machine does not move	Stand-by. Turn the appliance off and reinsert the Intelligent Key. Turn the program selection switch to the desired programme.
	Only for B 80 W Bp Dose Colruyt: Release the emergency buttons by turning.
	Release parking brake.
	Check battery; charge it if required.
	Make sure that all battery terminals are connected.
Insufficient water quantity	Check fresh water level, refill tank if necessary.
	Increase the water volume on the regulating knob for water volume.
	Unscrew the lock of the fresh water reservoir. Remove and clean the fresh water filter. Insert the filter and screw in the lock.
	Remove the water distribution strip from the cleaning head and clean water canal (only R cleaning head). Check hoses for blockages; clean if required.
Do not add detergents	Increase the water volume to activate the dosing pump.
	Check the detergent level
Insufficient vacuum performance	Clean the seals between waste water tank and cover and check for tightness, replace if required.
	Wastewater reservoir is full; shut off the appliance and empty the wastewater reservoir
	Clean protective turbine strainer.
	Clean the vacuum lips on the vacuum bar, replace if required
	Check suction hose for blockages; clean if required.
	Check the suction hose for tightness; replace if required.
	Check if the cover on the dirt water discharge hose is closed Check the setting of the vacuum bar.
Insufficient cleaning result	Check the brushes for wear, replace if required.
Vibrations during cleaning	Cleaning head has play, open the excenter lever and press the cleaning head all the way against the push handle, close the excenter lever.
	You might need to use softer brushes.
Brushes do not turn	Check if foreign matters block the brushes; remove foreign matter if required.
	If over-current switch in the electronics system has been triggered, turn programme selection switch to "OFF". Afterwards, set it back to the desired programme.

In case of faults that cannot be remedied using the table below please contact the customer service.

Accessories

BR appliance B 80 (brush roller accessories)

Description	Part no.: Working width 650 mm	Part no.: Working width 750 mm	Description	Packaging unit	Appliance requires
Brush roller, red (medium, standard)	6.906-935.0	6.906-936.0	Also for regular cleaning of heavily dirtied floors.	1	2
Brush roller, white (soft)	6.906-981.0	6.906-985.0	For polishing and cleaning sensitive floors.	1	2
Brush roller, orange (high/ low)	6.906-982.0	6.906-986.0	For scrubbing structured floors (safety tiles, etc.).	1	2
Brush roller, green (hard)	6.906-983.0	6.906-987.0	For thoroughly cleaning heavily dirtied floors and for removing the coating (for e.g. of wax, acrylate).	1	2
Brush roller, black (very hard)	6.906-984.0	6.906-988.0		1	2
Pad roller shaft	4.762-433.0	4.762-434.0	For intake of roller pads.	1	2
Roller pad, yellow (soft)	6.369-454.0	6.369-454.0	For polishing floors.	20	96; 106
Roller pad, red (medium)	6.369-456.0	6.369-456.0	For cleaning slightly dirtied floors.	20	96; 106
Roller pad, green (hard)	6.369-455.0	6.369-455.0	For cleaning normal to heavily dirtied floors.	20	96; 106

BD appliances B 80 (disc roller accessories)

Description	Part no.:	Part no.:	Description	Packaging unit	Appliance requires
	Working width 650 mm	Working width 750 mm			
Disk brush, natural (white)	4.905-012.0	4.905-020.0	For polishing floors.	1	2
Disk brush, white	4.905-011.0	4.905-019.0	For polishing and cleaning sensitive floors.	1	2
Disk brush, red (medium, standard)	4.905-010.0	4.905-018.0	For cleaning slightly dirtied or sensitive floors.	1	2
Disk brush, black (hard)	4.905-013.0	4.905-021.0	For cleaning heavily dirtied floors.	1	2
Driver plate pad	4.762-446.0	4.762-447.0	For intake of pads.	1	2

BR/BD appliances B 80 (vacuum bar accessories)

Description	Part no.:	Part no.:	Description	Packaging unit	Appliance requires
	Working width 850 mm	Working width 940 mm			
Rubber lip, blue	6.273-214.0	6.273-213.0	Standard	pair	1 pair
Rubber lip, transparent, grooved	6.273-207.0	6.273-208.0	oil-resistant	pair	1 pair
Rubber lip, transparent	6.273-229.0	6.273-205.0	Non-scarring	pair	1 pair
Rubber lip, transparent	6.273-290.0	6.273-291.0	For difficult floors	pair	1 pair
Vacuum bar, straight	4.777-401.0	4.777-402.0	Standard	1	1
Vacuum bar, bent	4.777-411.0	4.777-412.0	Standard	1	1

Technical specifications

		BR appliance B 80		BD appliance B 80	
		R 65	R 75	D 65	D 75
Power					
Nominal voltage	V	24			
Battery capacity	Ah (5h)	170, 180, 240			
Average power consumption	W	2200			
Drive motor output (rated output)	W	350			
Suction engine output	W	580			
Brush engine output	W	2 x 600			
Vacuuming					
Vacuum power, air volume (max.)	l/s	25			
Vacuuming power, negative pressure (max.)	mbar / kPa	167 / 16,7			
Cleaning brushes					
Brush speed	1/min	400 - 1550		180	
Dimensions and weights					
Theoretical surface cleaning performance	m ² /h	3900	4500	3900	4500
Max. working range incline	%	2			
Fresh/waste water tank volume	l	80/80			
Max. water temperature	°C	60			
max. water pressure	MPa (bar)	0,5 (5)			
Net weight (transport weight), with 240 Ah batteries	kg	280			
Total weight (ready for operation), with 240 Ah batteries	kg	370			
Values determined as per EN 60335-2-72					
Total oscillation value	m/s ²	<2,5			
Uncertainty K	m/s ²	<2,5			
Sound pressure level L _{pA}	dB(A)	69			
Uncertainty K _{pA}	dB(A)	2			
Sound power level L _{WA} + Uncertainty K _{WA}	dB(A)	83			
Subject to technical modifications!					

EU Declaration of Conformity

We hereby declare that the machine described below complies with the relevant basic safety and health requirements of the EU Directives, both in its basic design and construction as well as in the version put into circulation by us. This declaration shall cease to be valid if the machine is modified without our prior approval.

Product: Floor cleaner

Type: 1.259-xxx

Relevant EU Directives

2006/42/EC (+2009/127/EC)

2014/30/EU

2014/53/EU (TCU)

Applied harmonized standards

EN 60335-1

EN 60335-2-72

EN 60335-2-29: 2004+A2: 2010

EN 61000-3-2: 2014

EN 61000-3-3: 2013

EN 55012: 2007 + A1: 2009

EN 61000-6-2: 2005

EN 62233: 2008

TCU

EN 301 511 V12.5.1

EN 300 440 V2.1.1

EN 300 328 V2.2.2

EN 300 330 V2.1.1

Applied national standards

-

The undersigned act on behalf and under the power of attorney of the company management.



H. Jenner

Chairman of the Board of Management



S. Reiser

Director Regulatory Affairs & Certification

Documentation supervisor:

S. Reiser

Alfred Kärcher SE & Co. KG
Alfred-Kärcher-Straße 28-40
71364 Winnenden (Germany)
Tel.: +49 7195 14-0
Fax: +49 7195 14-2212

Winnenden, 2021/03/01

Declaration of Conformity

We hereby declare that the product described below complies with the relevant provisions of the following UK Regulations, both in its basic design and construction as well as in the version put into circulation by us. This declaration shall cease to be valid if the product is modified without our prior approval.

Product: Floor cleaner

Type: 1.259-xxx

Currently applicable UK Regulations

S.I. 2008/1597 (as amended)

S.I. 2016/1091 (as amended)

2014/53/EU (TCU)

Designated standards used

EN 60335-1

EN 60335-2-72

EN 60335-2-29: 2004+A2: 2010

EN 61000-3-2: 2014

EN 61000-3-3: 2013

EN 55012: 2007 + A1: 2009

EN 61000-6-2: 2005

EN 62233: 2008

TCU

EN 301 511 V12.5.1

EN 300 440 V2.1.1

EN 300 328 V2.2.2

EN 300 330 V2.1.1

National standards used

-

The signatories act on behalf of and with the authority of the company management



H. Jenner

Chairman of the Board of Management



S. Reiser

Director Regulatory Affairs & Certification

Documentation supervisor:

S. Reiser

Alfred Kärcher SE & Co. KG
Alfred-Kärcher-Straße 28-40
71364 Winnenden (Germany)
Tel.: +49 7195 14-0
Fax: +49 7195 14-2212

Winnenden, 2021/03/01

Accessories and Spare Parts

Only use original accessories and spare parts, they ensure the safe and trouble-free operation of the device.

For information about accessories and spare parts, please visit www.kaercher.com.