

KÄRCHER

makes a difference

Chariot 3 iExtract 26 Duo

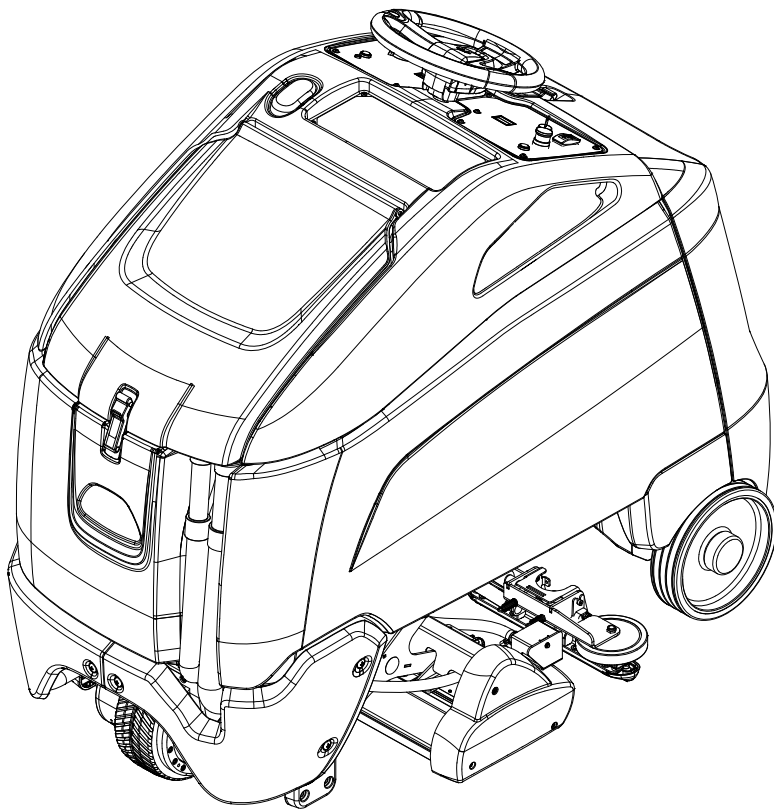

English 2

Français 57

Español 113



**Register
your product**

www.kaercher.com/welcome



86446700-B 07/15/21

Machine Data Log/Overview

Model:	_____
Date of Purchase:	_____
Serial Number:	_____
Dealer:	_____
Address:	_____
Phone Number:	_____
Sales Representative:	_____

Overview

The **Chariot® iExtract® CE26** is a battery powered, self-propelled Carpet Extractor intended for commercial use. The machine is a dual mode; interim and deep extraction carpet machine. Interim mode applies solution at a low flow rate agitated by the counter-rotating brushes with no solution recovery. Deep extraction applies solution at a high flow rate agitated by counter-rotating brushes and recovered by the dual vacuum shoes.

The machine is designed to apply a cleaning solution onto carpeted floor, and scrub the carpet with two counter-rotating brushes, then vacuum the soiled water back into the recovery tank.

Models:

1.008-115.0	CHARIOT 3 IEXTRACT 26, SHELF 205AH LA	1.008-131.0	CHARIOT 3 IEXTRACT 26 OA, 225AH
1.008-116.0	CHARIOT 3 IEXTRACT 26, SHELF 225AH LA	1.008-132.0	CHARIOT 3 IEXTRACT 26 OA, 234AH AGM
1.008-117.0	CHARIOT 3 IEXTRACT 26, SHELF 234AH AGM	1.008-133.0	CHARIOT 3 IEXTRACT 26 OA, OBC, 205AH
1.008-118.0	CHARIOT 3 IEXTRACT 26, OBC, 205AH LA	1.008-134.0	CHARIOT 3 IEXTRACT 26 OA, OBC, 225AH
1.008-119.0	CHARIOT 3 IEXTRACT 26, OBC, 225AH LA	1.008-135.0	CHARIOT 3 IEXTRACT 26 OA, OBC, 234AH AGM
1.008-120.0	CHARIOT 3 IEXTRACT 26, OBC, 234AH AGM	1.008-148.0	CHARIOT 3 IEXTRACT 26 LITHIUM SHELF
1.008-121.0	CHARIOT 3 IEXTRACT 26, INTERNATIONAL	1.006-723.0	CHARIOT 3 IEXTRACT 26 OBC
1.008-130.0	CHARIOT 3 IEXTRACT 26 OA, 205AH		

Warranty Registration

Thank you for purchasing a Kärcher North America product. Warranty registration is quick and easy. Your registration will allow us to serve you better over the lifetime of the product.

To register your product go to :

<https://www.kaercher.com/us/support/professional-services/professional-warranty-registration.html>

For customer assistance:

1-800-444-7654

KÄRCHER

Machine Data Log/Overview	2	Scrub Brush Removal	41
Table of Contents	3	Remove Brush Deck	42
How To Use This Manual	4	Replace Brush Deck Motor	42
 		Scrub Deck Actuator Removal/Replacement	42
Safety		Replace Pump - Off-Aisle Option	42
Safety Label Locations	5	Brush Motor Carbon Brush Replacement	43
IMPORTANT SAFETY INSTRUCTIONS	6	Solution	44
HAZARD INTENSITY LEVEL	7	Vacuum	46
 		Recovery Tank Float Shut-off	47
Operations		To Repair or Replace Vacuum Motors	47
How This Machine Works	8	Drive Motor	48
Components	9	Electric Parking Brake Engagement	49
Drive Controls	11	Drive Motor Carbon Brush Replacement	49
Scrub Controls	14	Transporting	50
Technical Specifications	16	Circuit Protection	51
Pre-Run Machine Inspection	18	Troubleshooting	52
Starting Machine	18	Controller Fault Codes	54
Emergency Stop Procedures	18	Suggested Spare Parts	56
Filling Solution Tank	18		
Normal Scrubbing	19		
To Begin Scrubbing	20		
To Stop Scrubbing	20		
Emptying and Cleaning Tanks	21		
Solution Tank	21		
Vacuum Shoes	22		
To Operate Off-Aisle Cleaning Option	23		
Maintenance			
Service Schedule	25		
Batteries	26		
Charging Batteries	28		
Changing Batteries	30		
Battery Charger Programming	31		
Lithium Battery (Optional)	32		
Operating Limits	33		
Handling	34		
Installation - Single Battery	34		
Installation	34		
Operation	34		
On-Off	34		
Charging	35		
Discharging	35		
Storage	35		
Protection & Faults	35		
Faults & Corrective Actions	35		
Service & Maintenance	36		
Troubleshooting	36		
Vacuum Shoes	38		
Vacuum Shoes	39		
Vacuum Shoe Removal and Cleaning	39		
Vacuum Shoe Lift Actuator Removal/Replacement	39		
Brush Deck	40		

How To Use This Manual

This manual contains the following sections:

- How to Use This Manual
- Safety
- Operations
- Maintenance

The HOW TO USE THIS MANUAL section will tell you how to find important information for ordering correct repair parts.

Parts may be ordered from authorized dealers. When placing an order for parts, the machine model and machine serial number are important. Refer to the MACHINE DATA box which is filled out during the installation of your machine. The MACHINE DATA box is located on the inside of the front cover of this manual.

Model:	_____
Date of Purchase:	_____
Serial Number:	_____
Dealer:	_____
Address:	_____
Phone Number:	_____
Sales Representative:	_____

The model and serial number of your machine are located on the back of the machine.

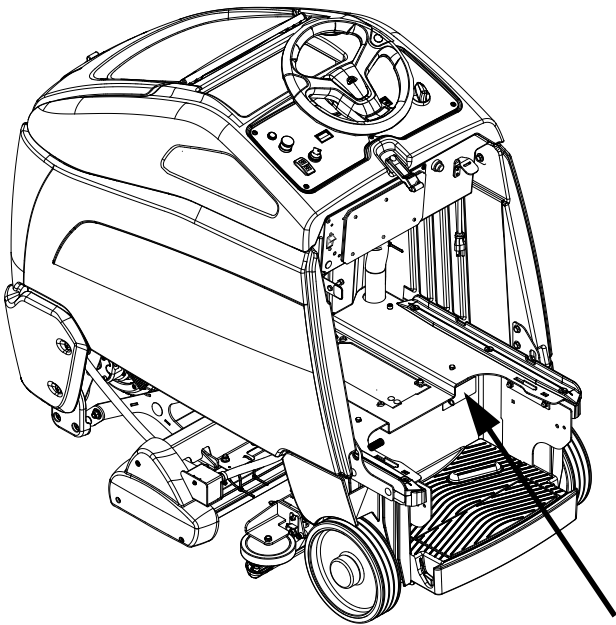

The SAFETY section contains important information regarding hazardous or unsafe practices of the machine. Levels of hazards are identified that could result in product damage, personal injury, or severe injury resulting in death.

The OPERATIONS section is to familiarize the operator with the operation and function of the machine.

The MAINTENANCE section contains preventive maintenance to keep the machine and its components in good working condition. They are listed in this general order:

- Service Schedule
- Batteries
- Brush Deck
- Solution Strainer & Pump
- Vacuum & Float Shut-Off
- Drive Motor & Brake
- Troubleshooting

NOTE: The manual part number is located on the lower right corner of the front cover.

Safety Label Locations

These drawings indicate the location of safety labels on the machine. If at any time the labels become illegible, promptly replace them.

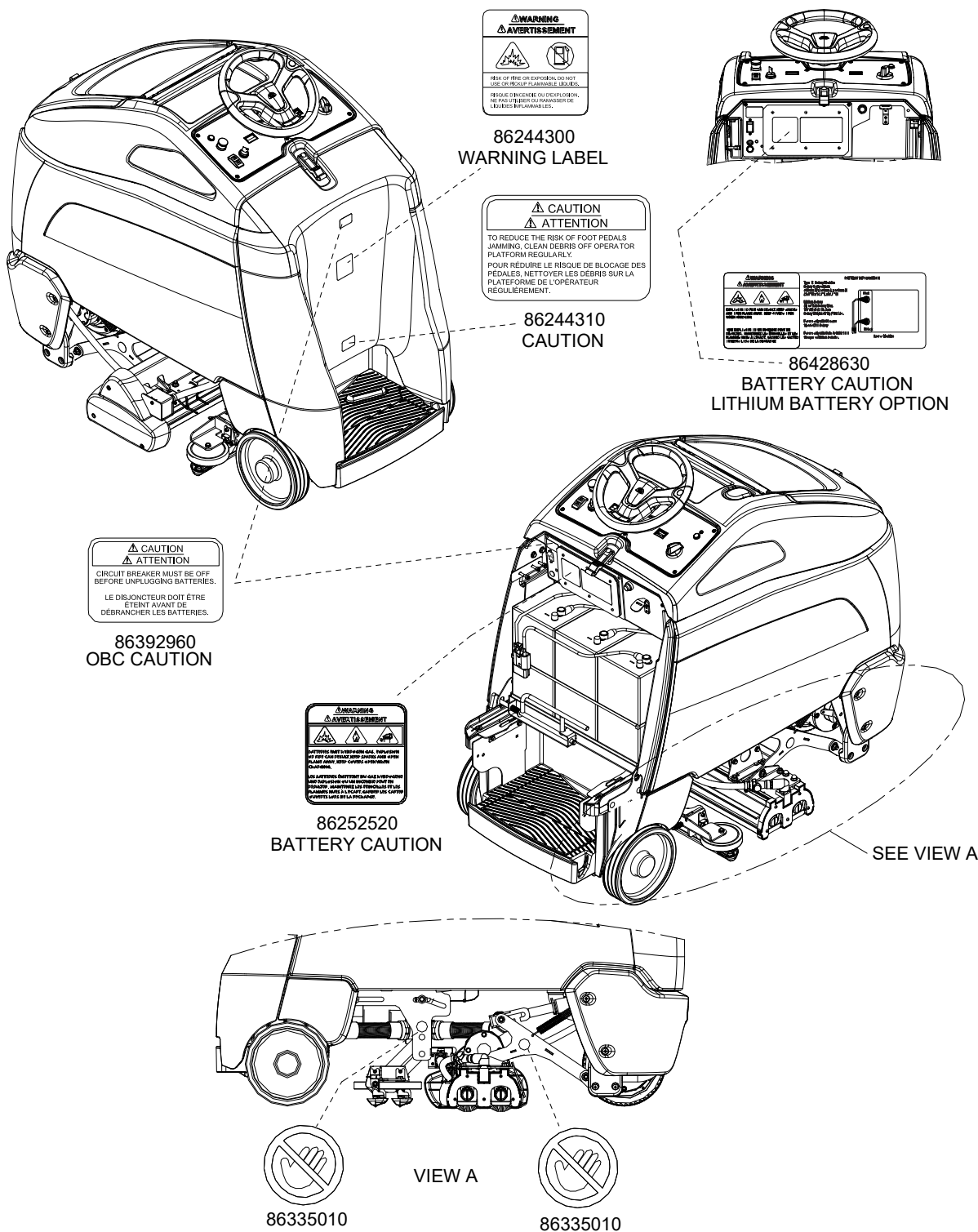

IMPORTANT SAFETY INSTRUCTIONS

When using this machine, basic precaution must always be followed, including the following:
READ ALL INSTRUCTIONS BEFORE USING THIS MACHINE.

⚠ WARNING: To reduce the risk of fire, electric shock, or injury:

Use only indoors. Do not use outdoors or expose to rain.

Use only as described in this manual. Use only manufacturer's recommended components and attachments.

If the machine is **not working properly**, has been dropped, damaged, left outdoors, or dropped into water, return it to an authorized service center.

Do not operate the machine with any openings blocked. Keep openings free of debris that may reduce airflow.

This machine **is not** suitable for picking up hazardous dust.

Do not operate this machine near flammable fluids, dust or vapors. Do not expose to fire.

Maintenance and repairs **must be done** by qualified personnel.

If foam or liquid comes out of machine, **switch off immediately**.

Disconnect battery before cleaning or servicing.

Do not use a visibly damaged battery pack or appliance. If the battery housing is damaged, do not touch exposed contents.

Do not modify or attempt to repair the appliance or the battery pack.

Lithium Battery Option: For use only with Discover Lithium battery 12-36-6700 and Delta Q QuiQ 1000 Charger.

Before the machine is discarded, the batteries **must be removed** and properly disposed of.

Make sure all warning and caution labels **are legible and properly attached** to the machine.

During operation, attention shall be paid to other persons, especially children.

Before use all covers and doors shall be put in the positions specified in the instructions.

When leaving unattended, secure against unintentional movement.

The machine shall only be operated by instructed and authorized persons.

When leaving unattended, switch off or lock the main power switch to prevent unauthorized use.

Only chemicals recommended by the manufacturer shall be used.

This appliance has been designed for use with the brushes specified by the manufacturer. The fitting of other brushes may affect its safety.

Do not use on surfaces having a gradient of over 10% (6 degrees).

READ AND SAVE THESE INSTRUCTIONS

The following symbols are used throughout this guide as indicated in their descriptions:

HAZARD INTENSITY LEVEL

There are three levels of hazard intensity identified by signal words **-WARNING** and **CAUTION** and **FOR SAFETY**. The level of hazard intensity is determined by the following definitions:

WARNING:

WARNING - Hazards or unsafe practices which **COULD** result in severe personal injury or death.

CAUTION:

CAUTION - Hazards or unsafe practices which could result in minor personal injury or product or property damage.

FOR SAFETY: To identify actions which must be followed for safe operation of equipment.

Report machine damage or faulty operation immediately. Do not use the machine if it is not in proper operating condition. Following is information that signals some potentially dangerous conditions to the operator or the equipment. Read this information carefully. Know when these conditions can exist. Locate all safety devices on the machine. Please take the necessary steps to train the machine operating personnel.

FOR SAFETY:

DO NOT OPERATE MACHINE:

Unless Trained and Authorized.

Unless Operation Guide is Read and understood.

In Flammable or Explosive areas.

In areas with possible falling objects.

WHEN SERVICING MACHINE:

Avoid moving parts. Do not wear loose clothing; jackets, shirts, or sleeves when working on the machine. Use Kärcher North America approved replacement parts.

WARNING:

Batteries emit hydrogen gas. Explosion or fire can result. Keep sparks and open flame away. Keep battery compartment open during charging. Keep sparks and flames away from the batteries. Do not smoke around batteries.

WARNING:

Disconnect batteries before working on machine. Only qualified personnel should work inside machine. Always wear eye protection and protective clothing when working on or near batteries. Avoid skin contact with the acid contained in the batteries.

WARNING:

Never allow metal to lie across battery tops.

How This Machine Works

The Chariot® iExtract® 26 is a battery powered, self-propelled Carpet Extractor intended for commercial use. The machine is a dual mode; interim and deep extraction carpet machine. Interim mode applies solution at a low flow rate agitated by the counter-rotating brushes with no solution recovery. Deep extraction applies solution at a high flow rate agitated by counter-rotating brushes and recovered by the dual vacuum shoes.

The machine is designed to apply a cleaning solution onto carpeted floor, and scrub the carpet with two counter-rotating brushes, then vacuum the soiled water back into the recovery tank. The machine's primary systems are the solution system, scrub system, recovery system, and operator control system.

The function of the solution system is to store cleaning solution and deliver it to the scrub system. The solution system is gravity fed. The solution system consists of the solution tank, strainer, valve, manifold and controls. The solution tank stores cleaning solution (water and detergent) until it is delivered to the scrub system. The strainer protects the valve from debris. The strainer prevents debris from entering the supply lines, valve, and manifold. The valve automatically prevents solution flow unless the scrub brushes are turned on and the machine is being propelled.

The function of the scrub system is to scrub the carpet and lift and groom the carpet pile. The scrub system consists of two cylindrical counter-rotating brushes, a motor, lift actuator, and controls. The brushes scrub the carpet as the motor drives the brushes. The counter-rotating action of the brushes applies and agitates the solution into the carpet.

The function of the recovery system is to vacuum the soiled water back into the recovery tank. The recovery system consists of two vacuum shoes, two vacuum motors, float ball filter, and controls. The vacuum shoes extract the dirty solution from the carpet as the machine moves forward. The vacuum motors provide suction to draw the dirty solution off the carpet and into the recovery tank. The float ball filter protects the vacuum fan from debris and foam. The recovery tank stores the dirty solution.

The function of the operator control system is to control the direction and speed of the machine. The directional control system consists of the direction control drive reset switch, throttle pedal, emergency stop/brake switch, steering wheel, propel controller, and drive wheel. The directional control drive reset switch signals forward or reverse direction and makes sure the operator is on platform before machine will propel. The controller interprets signals from the throttle pedal to command the drive wheel to propel or slow the machine. The steering wheel points the drive wheel in the direction desired by the operator. The parking brake automatically engages when the operator steps off the platform. The emergency stop/brake can be used to hold the machine on slopes.

NOTE: Impact to machine may cause damage.

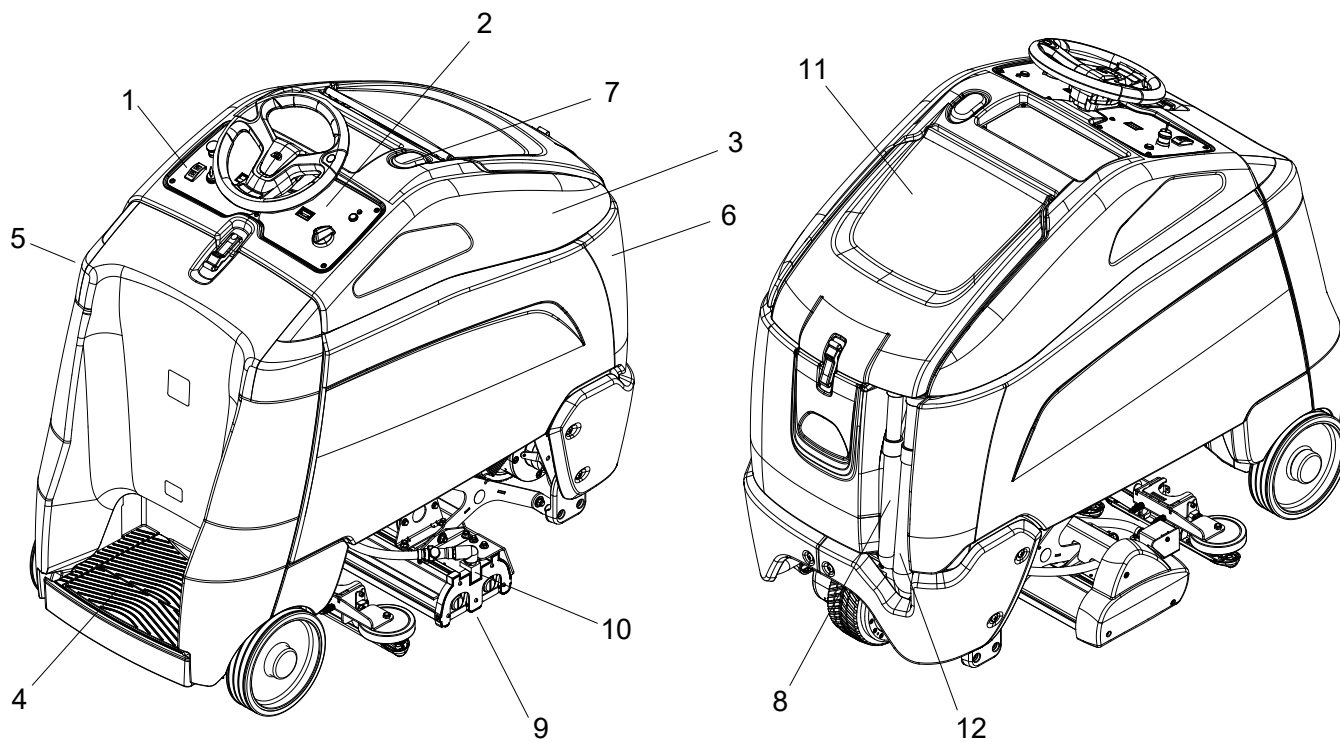

Components

- 1. Control Panel - Drive
- 2. Control Panel - Scrub
- 3. Console
- 4. Pedal Platform
- 5. Rear Cover
- 6. Tank
- 7. Recovery Sight Dome
- 8. Solution Drain Hose
- 9. Brush Deck
- 10. Solution Supply
- 11. Recovery Lid
- 12. Recovery Drain Hose

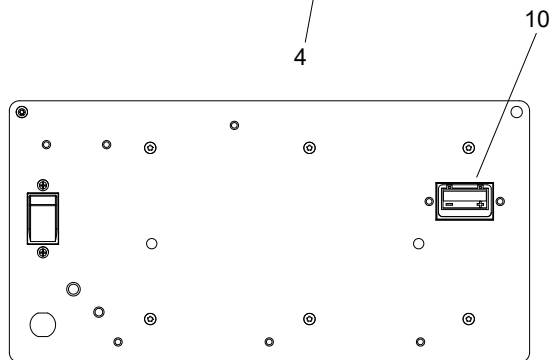
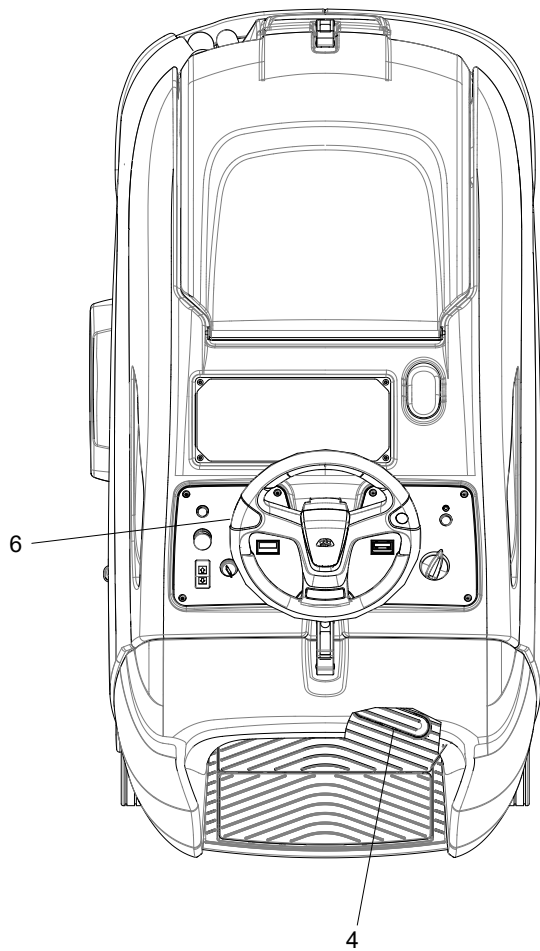
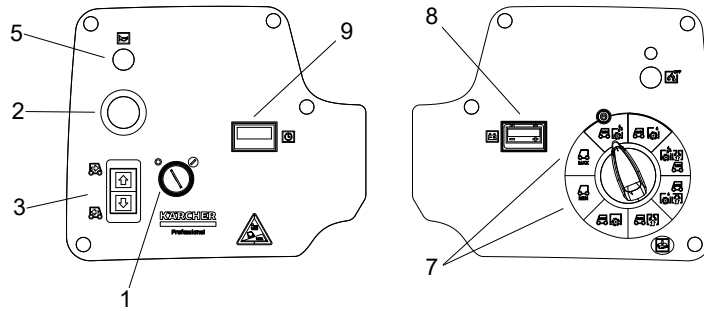

LOWER CONTROL PANEL

Drive Controls

- 1. Key Switch**
- 2. Emergency Stop/Brake Switch**
- 3. Directional Control / Drive Reset Switch**
- 4. Throttle Pedal**
- 5. Horn Button**
- 6. Steering Wheel**
- 7. Speed Control**
- 8. Battery Discharge Indicator**
- 9. Hour Meter**
- 10. Error Indicator (lithium only)**

1. KEY SWITCH

Controls the power for machine functions.

To turn the machine power on, rotate key clockwise.

To turn the machine off, rotate key counterclockwise.

When the key is turned on the battery symbol will flash while the system runs self-diagnostics and returns scrub deck and squeegee to their raised positions, if necessary. The controller will not respond to other commands until this routine is complete.

2. EMERGENCY STOP / BRAKE SWITCH

This safety feature is designed to cut all power to the machine at any time and apply parking brake.

To shut the machine power off, push the Emergency Stop Switch, this will also engage the parking brake and cause the machine to stop immediately. Excessive emergency stop usage can cause premature brake wear; use only when necessary.

To reset the machine, rotate the switch clockwise.

3. DIRECTIONAL CONTROL / DRIVE RESET SWITCH

This safety feature is designed to ensure safe engagement of propel drive. Each time the machine power is turned on, or each time an operator steps on to the platform, the Drive Reset Switch must be pushed before machine will propel.

Controls the direction of travel of the vehicle. The lit arrow on the switch indicates direction of travel.

To travel forward, press the top of the switch.

To travel in reverse, press the bottom of the switch.

4. THROTTLE PEDAL

Controls the speed of the vehicle within the speed control setting selected. Pressing the pedal causes the machine to travel in the direction selected by the Directional Control Switch.

To increase speed, increase pressure on the pedal.

To decrease speed, decrease pressure on the pedal.

5. HORN BUTTON

The horn is activated by pressing the horn button.

6. STEERING WHEEL

The steering wheel turns the front wheel causing the machine to change direction.

7. SPEED CONTROL

Controls the maximum speed of the machine. There are two transport settings, slow and fast.

To change speed, rotate the dial to either slow or fast position. The speed for fast and slow are as indicated on the control panel by the symbols shown below. The throttle pedal will always regulate the speed between 0 and maximum.

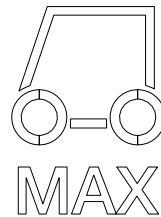
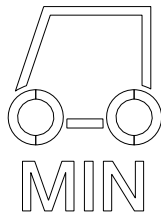

8. BATTERY CHARGE LEVEL INDICATOR

Indicates the charge level of the batteries.

The meter display is divided into 10 bars. Bars illuminated on the far right indicate full charge. Bars flashing near the left side indicate the batteries should be recharged. Further operation of the machine could damage the machine or the batteries.

When the machine is left overnight with less than a full charge, the display may initially indicate a full charge. It will also indicate a full charge if the batteries are disconnected, then reconnected. After a few minutes of operation the meter will give the correct charge level.

9. HOUR METER

Records the number of hours the machine has been in scrubbing operation. This information is useful in determining when to service the machine.

10. ERROR INDICATOR (LITHIUM ONLY)

Indicates any errors that the machine may experience when the machine is equipped with lithium batteries.

Scrub Controls

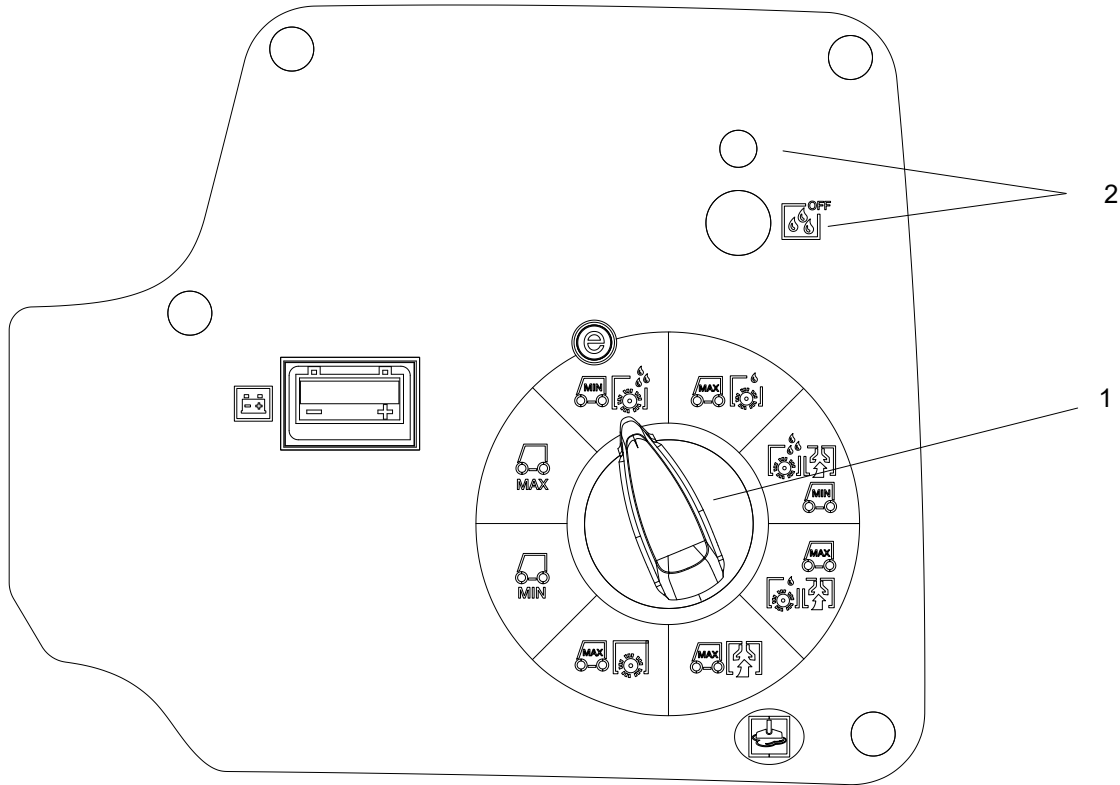

1. Function Mode Dial

The first two positions are for transport only. See drive controls section.

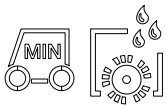

Interim Mode-Slow

This mode is used for interim cleaning. In this mode the machine will propel at slow speed. The brush deck will automatically lower to contact the floor. The water will flow at a low rate set by the controller. Water will automatically shut off in neutral and resume as machine propels forward. The vacuum shoes will remain off the floor and the vacuum motors will be off in this mode.

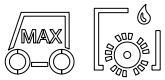

Interim Mode-Fast

This mode is used for interim cleaning. In this mode the machine will propel at fast speed. The brush deck will automatically lower to contact the floor. The water will flow at a low rate set by the controller. Water will automatically shut off in neutral and resume as machine propels forward. The vacuum shoes will remain off the floor and the vacuum motors will be off in this mode.

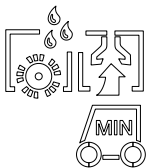

Deep Extraction-Slow

This mode is used for deep carpet extraction. In this mode the machine will propel at slow speed. The brush deck will automatically lower to contact the floor. The vacuum shoes will automatically lower to the floor and the vacuum motors will turn on. The water will flow at a high rate. Water will automatically shut off in neutral and resume as machine propels forward. The vacuum shoes will lift off the floor in reverse with the vacuum motors having a delayed shut off to clear the hoses.

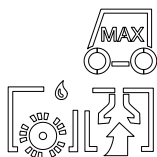

Deep Extraction-Fast

This mode is used for deep carpet extraction. In this mode the machine will propel at fast speed. The brush deck will automatically lower to contact the floor. The vacuum shoes will automatically lower to the floor and the vacuum motors will turn on. The water will flow at a high rate. Water will automatically shut off in neutral and resume as machine propels forward. The vacuum shoes will lift off the floor in reverse with the vacuum motors having a delayed shut off to clear the hoses.



Vacuum Only Mode

This mode is used for solution recovery. In this mode the machine will propel at fast speed. The brush deck will be up and the motor off. There will be no solution flow in this mode. The vacuum shoes will automatically lower to the floor and the vacuum motors will turn on. The vacuum shoes will lift off the floor in reverse with the vacuum motors having a delayed shut off to clear the hoses.

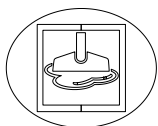

Off-Aisle Tool Mode (Wand/Hand Tool)

This mode is used for Off-Aisle tool use. The dial is set in the same position as the Vacuum Only Mode. Once the Off-Aisle tool button on the lower control panel is pushed, the machine will not propel. The vacuum motors and pump will come on and solution will flow.

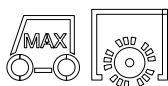

Brush Only Mode

This mode is used for carpet agitation. In this mode the machine will propel at fast speed. The brush deck will automatically lower to contact the floor. There will be no solution flow in this mode. The vacuum shoes will remain off the floor and the vacuum motors will be off in this mode.

2. Solution Button and Indicator

The button enables and disables solution flow. When the green indicator is illuminated, solution flow is enabled.

Operations

Technical Specifications

ITEM	DIMENSION/CAPACITY
Nominal power	1944 W
Rated Voltage	36 Volts DC
Rated Amperage	54 amps
Batteries	3 X12 Volt 205-234 AH @ 20 hr. rate
Battery Compartment Dimensions	21 in. x 16 in. x 17 in. tall (533mm x 406mm x 432mm)
Battery, Lithium	38.4 Volts
Battery, Lithium - Dimensions	(375mm x 347.5 x 471.5 mm)
Brush Motor	.5 HP (373W)
Vacuum Motors	2 X .75 HP (560W)
Maximum flow rate of vacuum motors	78.0 cfm (36.8 liters per second)
Maximum suction of vacuum motors	71.8 inches of water (17.8 kPa)
Propelling Motor	.75 HP (600 W)
Mass (GVW)	Ev185A-A = 1226 lbs, (557 kg) J185H-AC = 1193 lbs. (542 kg) J185P-AC = 1151 lbs. (523 kg)
Weight empty without batteries	418 lbs (190 kg)
Solution Control	Variable with automatic shut-off in neutral
Solution capacity	25 gal (95 L)
Recovery capacity	27 gal (102 L)
Scrub brush diameter	4 inch (102 mm)
Scrub brush pressure	Floating
Brush speed	1025 rpm
Tires	10 in. (254mm) Solid scrubber compound rear, urethane front
Extracting speed 1	.5 mph (.8km/hour)
Extracting speed 2	1.0 mph (1.7 km/hour)
Foundation Pressure	134 psi (923 Kpa)
Maximum Speed	4.1 miles/hour (6.5 km/hour)
Frame Construction	Powder coated steel
Brake	Electrical parking brake, sets automatically whenever operator steps off platform or engages emergency stop.
Minimum aisle u-turn width	64 in. (1630 mm)
Maximum rated climb and descent angle	10% (6 degrees)
Sound Pressure Level	69.0 dBA

ITEM	MEASURE
Height	50.0 inches (1270 mm)
Length	56.1 inches (1425 mm)
Width	29.5 inches (749 mm)
Width of scrub path	26 inches (660mm)

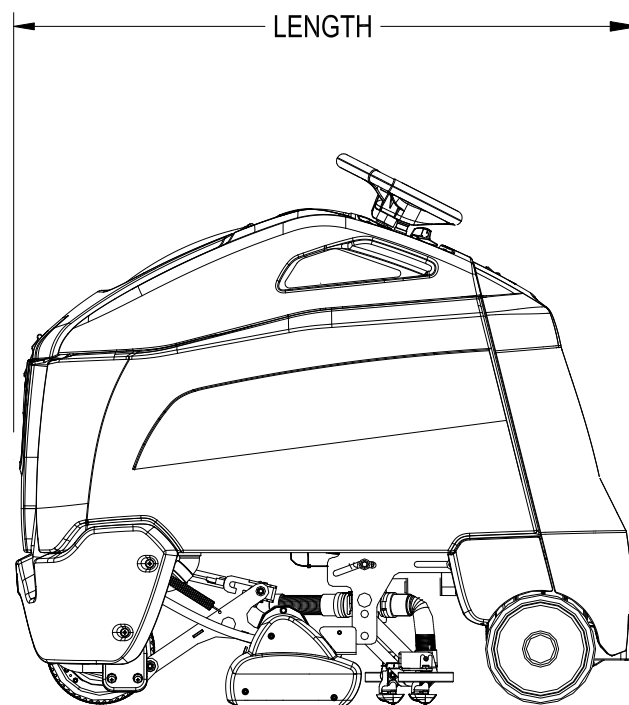
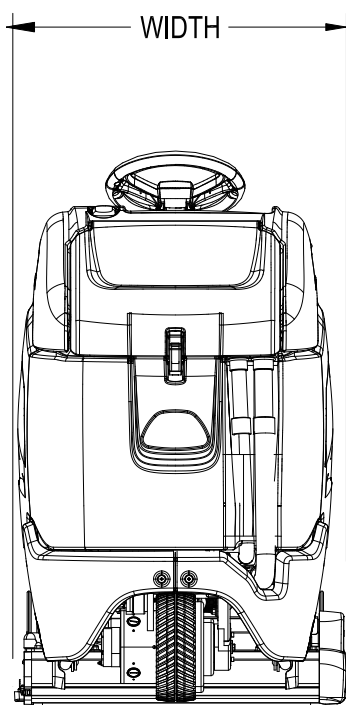

⚠ CAUTION:

This appliance is not intended for use by persons (including children) with reduced physical, sensory or mental capabilities, or lack of experience and knowledge, unless they have been given supervision or instruction concerning use of the appliance by a person responsible for their safety. Children should be supervised to ensure that they do not play with the appliance.

Operations

Machine Operation

Pre-Run Machine Inspection

Do a pre-run inspection to find possible problems that could cause poor performance or lost time from breakdown. Follow the same procedure each time to avoid missing steps.

NOTE: Perform Pre-run Machine Check before operating machine. See Service Schedule in Maintenance Section.

Starting Machine

FOR SAFETY: Before starting machine, make sure that all safety devices are in place and operating properly.

1. The operator should be on the pedal platform. The throttle pedal must be in the neutral position.
2. Turn the machine power on by turning key switch clockwise to the "ON" position.
3. Press the Drive Reset Directional Control Switch to reset and set the intended direction for travel.
4. Press lightly on the throttle pedal with right foot.

Emergency Stop Procedures

1. Push in emergency stop button. This will also engage the parking brake and cause the machine to stop immediately.

Filling Solution Tank

FOR SAFETY: Before leaving or servicing machine; stop on level surface, turn off machine and remove key.

1. Turn the machine power off.
2. Remove solution cover.
3. Fill the solution tank with clean water, leaving enough room for the required amount of detergent. The solution tank capacity filled to fill inlet is 25 gallons (95 liters). The water must not be hotter than 140° F (60°C) to prevent damage to the tank.
4. Measure the chemical into the solution tank. The solution cover is also a 2 oz. (60 ml) measuring cup. Liquid chemicals should be added to the solution tank after filling with water. Dry chemicals should be thoroughly mixed before being added into solution tank. Commercially available, high alkaline floor cleaners, are suitable for use in the solution system.

NOTE: Read the chemical manufacturers recommended proportion instructions.

5. Replace solution tank cover.

⚠ WARNING:

Flammable materials can cause an explosion or fire. Do not use flammable materials in the tanks.

Normal Scrubbing

Plan the scrubbing pattern in advance. The longest track is around the perimeter of the area to be cleaned. For efficient operation, the runs should be the longest possible without turning, stopping, or raising or lowering scrub deck/squeegee.

In order to achieve the best possible results, the area which is to be cleaned should be swept before scrubbing. Large debris, strings and wire must be removed to prevent being caught in brushes or vacuum shoe.

If the machine is allowed to stand in neutral with the scrub deck down, the solutions flow stops and brush motors stop. If either forward or reverse travel is selected, the solution flow will continue in the same setting and the scrub brush motors will continue in their same setting once movement of machine begins. Overlap the brush path and avoid transporting over previously cleaned areas.

INEFFICIENT SCRUBBING PATH

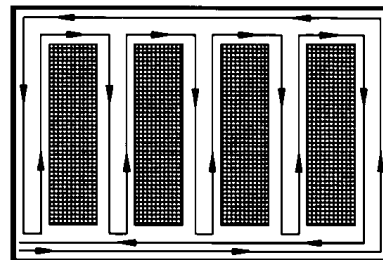

RECOMMENDED SCRUBBING PATH

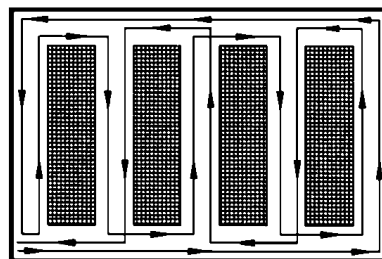

Operations

To Begin Scrubbing

⚠ WARNING:

When operating the machine around people, pay close attention for unexpected movement. Use extra caution around children.

⚠ WARNING:

Flammable liquids and/or reactive metals can cause explosions or fire! Do not pick up.

1. Stand on the operator platform. Throttle pedal must be in neutral position.
2. Turn machine power on.
3. Press the Drive Reset / Directional Control Switch, selecting the desired travel direction.
4. Position the function control knob to the desired operation. The scrub deck and vacuum shoes will lower, and the vacuum will turn on.
5. Drive machine forward to begin scrubbing. The scrub brush motor will run and solution will flow when the throttle is depressed.

NOTE: Shut machine off immediately if water or foam is expelled from the machine.

NOTE: Solution flow is automatically shut off when brush motor stops. When brush motor is activated, flow automatically resumes.

To Stop Scrubbing

1. Rotate the function knob to either transport position. The brush motor will stop and the scrub deck will rise to the park position. After 10 seconds the vacuum shoe will raise, and 10 seconds later the vacuum motor will turn off. This delay is to clear the vacuum hose of recovered solution.
2. Allow the throttle pedal to return to neutral.
3. Turn machine power off.

FOR SAFETY: Before leaving or servicing machine: stop on level surface, turn off machine and remove key.

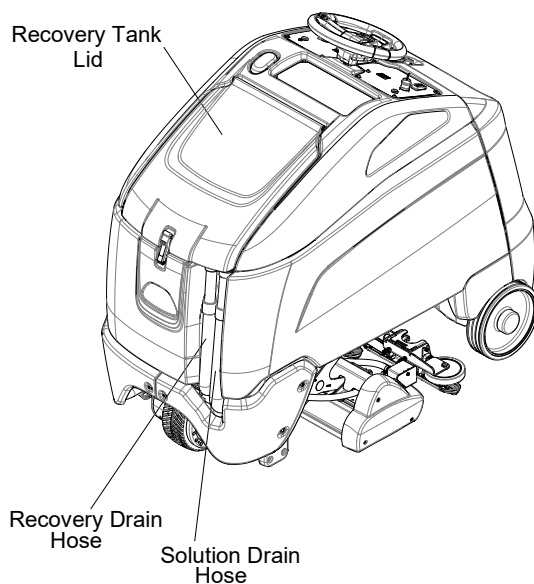

Solution Tank

1. Remove the recovery tank lid.
2. Pull the solution drain hose from its mounting pocket. Unscrew the cap, then lower hose in direction of drain.
3. Remove the solution tank cap.
4. Flush the solution tank out with clean water and run several gallons of clean water through systems. Do not use water hotter than 140°F (60°C) to clean tank. Damage may occur.
5. If machine is to be stored, leave solution cap off.

NOTE: Never allow solution to remain in tank. Damage to tank, seals and valves could occur.

Emptying and Cleaning Tanks

1. Park the machine next to a floor drain. Drain hoses are at the front of the machine.
2. Turn the machine power off.

Recovery Tank

1. Open the recovery tank lid. Pull the recovery drain hose from the mounting bracket. Open cap, then lower hose in direction of the drain. Do not stand in front of end of hose. Recovered solution will come out with force.
2. Flush the recovery tank out with clean water. Do not use water hotter than 140°F (60°C) to clean tank. Damage may occur.
3. Clean debris bin.
4. Clean off the float shut-off system and inspect for free movement of float.
5. Replace the drain hose cap and secure drain hose.
6. If machine is to be stored, leave the recovery tank lid propped open.

Vacuum Shoes

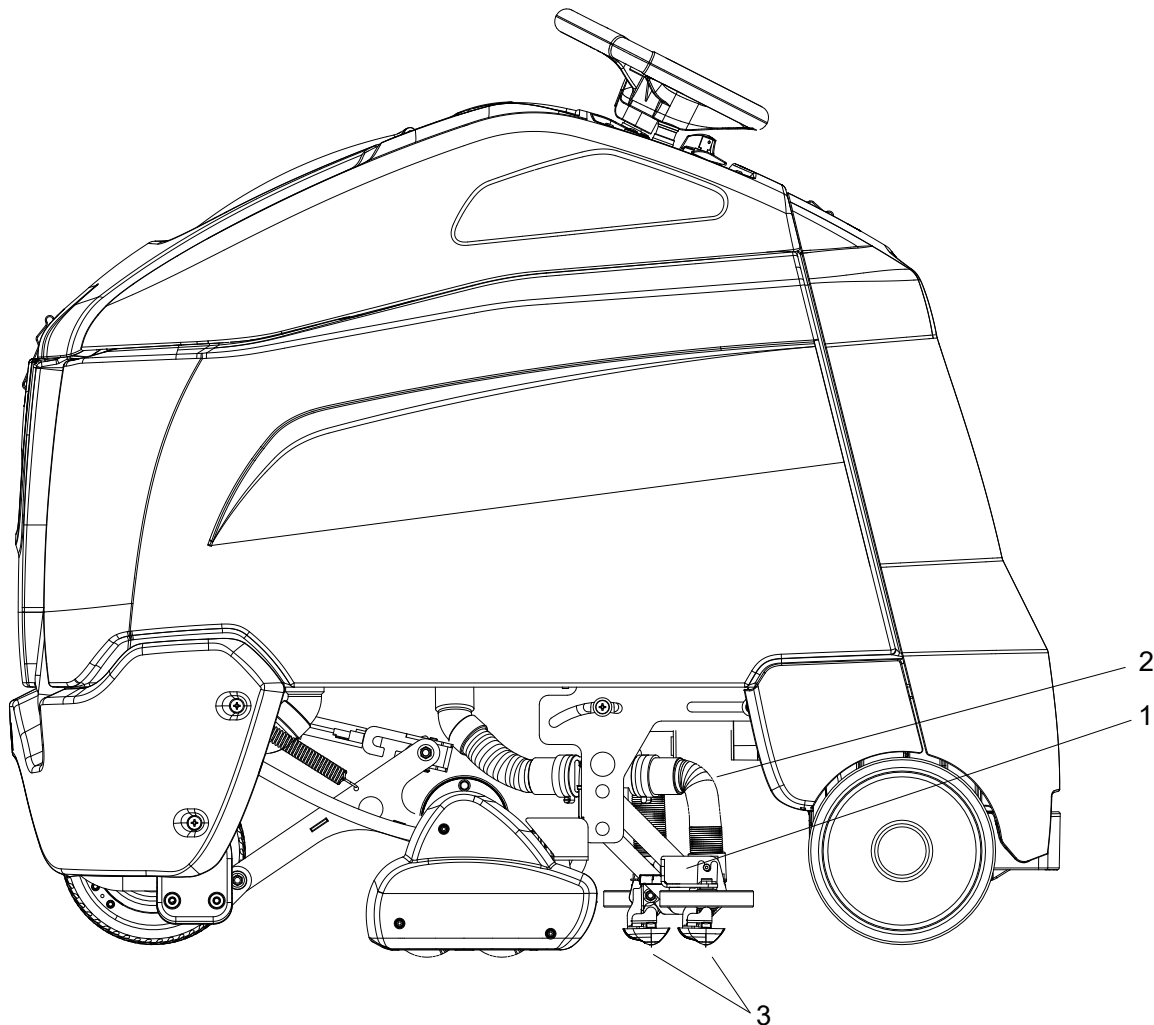

1. Vacuum Shoe Release

The latch holds the vacuum shoe in place.

2. Vacuum Hoses and Y-Tube

Vacuum shoe hose and y-tube carry the recovered solution to the recovery tank.

3. Vacuum Shoes

Contact the carpet to recover solution.

Vacuum Shoes

The dual offset vacuum shoes are designed to remove soiled solution from the carpet. The plastic vacuum shoe glides minimize damage to the carpet. The clear plastic cover allows the operator to verify the vacuum shoe is operating without clogging. The quick release latch allows for tool free removal for easy cleaning.

To Operate Off-Aisle Cleaning Option

1. Turn Function Mode Dial to the Deep Extraction Icon shown below to lower vacuum shoes.

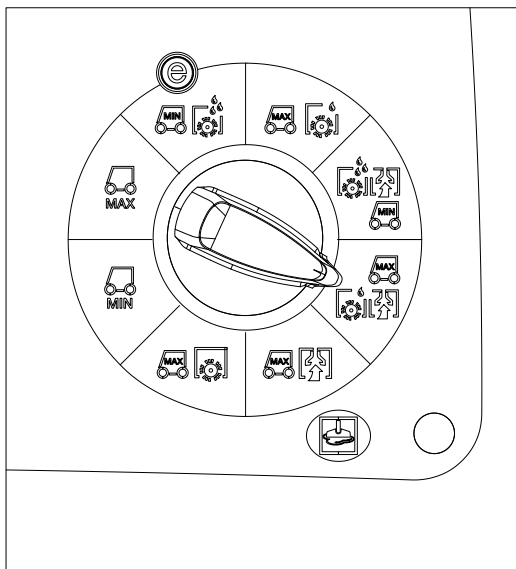

2. Turn key to off when vacuum shoes touch the floor.
3. Disconnect water supply from deck and connect to off-aisle pump.
4. Disconnect both vacuum hoses from vacuum shoes and connect to off-aisle vacuum port connections.

From right side of machine:

- a. Remove hose from left side vacuum shoe and connect to connection port nearest to you

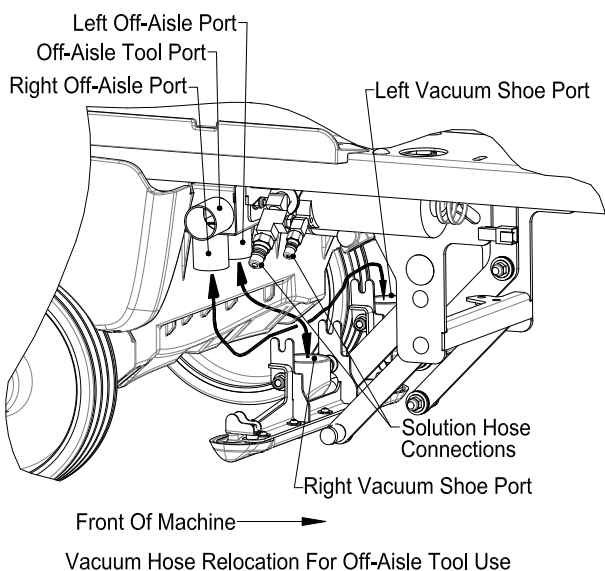

- b. Remove hose from right side vacuum shoe and connect to connection port towards center of machine.

5. Connect Off-Aisle Tool vacuum hose and Solution hose.
6. Turn key to "on".
7. Turn Function Mode Dial to the Vacuum Only Mode Icon as shown below.

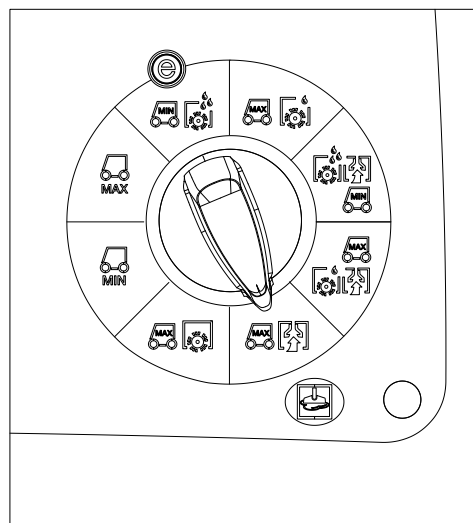

8. Push in off-aisle pump switch button on lower control panel, lower left side. The green indicator will illuminate on main control panel and now the solution flow is enabled.

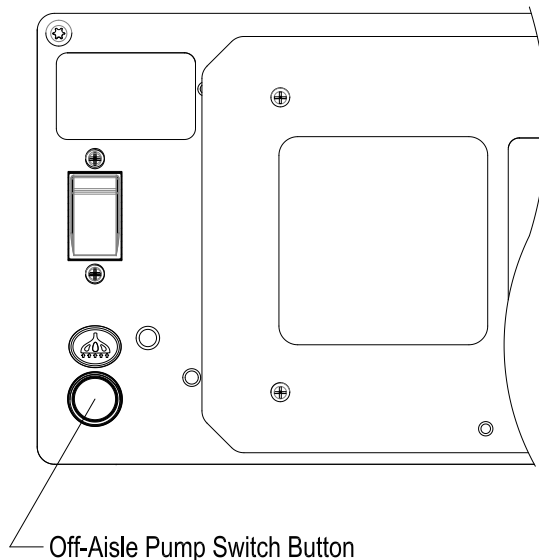

Service Schedule

MAINTENANCE	BEFORE EACH WORK PERIOD	AFTER EACH WORK PERIOD	50 HRS	100 HRS	200 HRS
Check water level of batteries after charging; add distilled water if necessary. (Wet cell only)	*				
Check that recovery lid seals tightly.	*				
Visually check for damaged or worn wheels.	*				
Check brushes for proper installation.	*				
Check vacuum hose connections.	*				
Check that vacuum shoes are securely attached.	*				
Check for securely attached drain hoses, plug and cap.	*				
Check pedal, brake and steering for proper operation.	*				
Clean out recovery tank and debris bin.		*			
Clean and inspect float shutoff.		*			
Clean out solution tank.		*			
Clean and inspect solution filter strainer.		*			
Run vacuum motors to dry.		*			
Clean brushes and check wear.		*			
Clean vacuum shoes and check wear.		*			
Clean outside of tanks, check for damage.		*			
Store with recovery lid propped open.		*			
Charge batteries if needed.		*			
Clean off top of batteries.			*		
Check battery cells with hydrometer. (Wet cell only)			*		
Inspect vacuum shoes.			*		
Check battery connections are tight.			*		
Inspect and clean interior of solution manifold.			*		
Clean battery cases and battery compartment.				*	
Check parking brake.					*
Clean pivot points on vacuum shoes and scrub deck lift.					*
Check all motors for carbon brush wear.					*
Check motor commutators.					*
Check steering chain tension.					*

Batteries

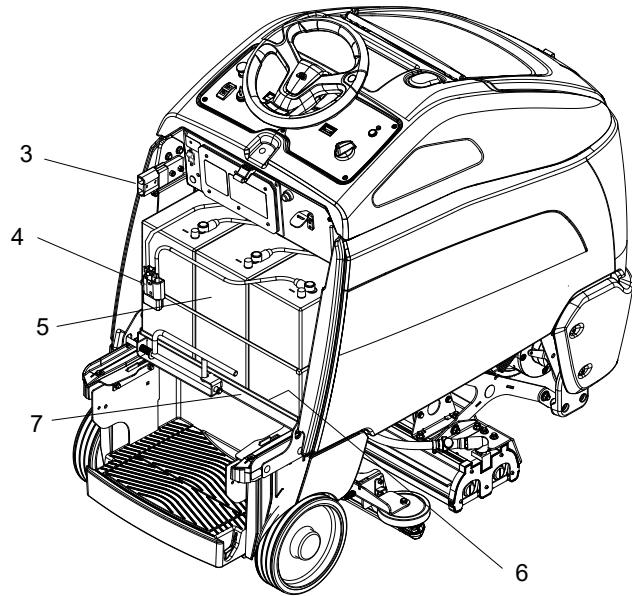
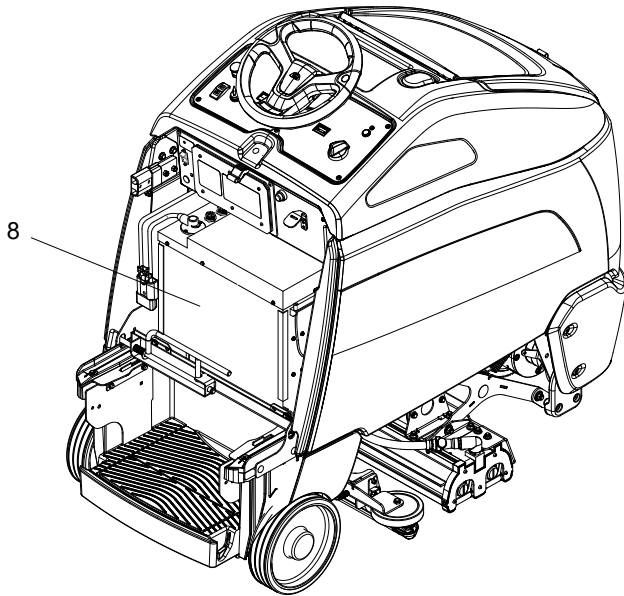
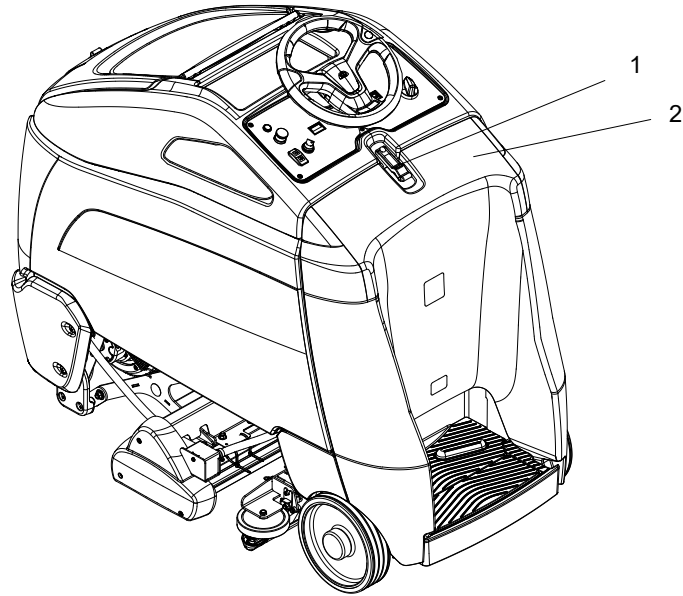

1. Rear Cover Latch
2. Rear Cover
3. Battery Connector-Machine
4. Battery Connector-Battery
5. Batteries
6. Battery Tray Liner
7. Battery Tray
8. Batteries - Lithium Option

Batteries (Wet Cell Only)

The batteries provide the power to operate the machine. The batteries require regular maintenance to keep them operating at peak efficiency.

The machine batteries will hold their charge for long periods of time, but they can only be charged a certain number of times. To get the greatest life from the batteries, charge them when their charge level reaches 25% of a full charge. Use a hydrometer to check the charge level.

Do not allow the batteries to remain in a discharged condition for any length of time. Never expose a discharged battery to temperatures below freezing. Discharged batteries will freeze causing cracked cases. Do not operate the machine if the batteries are in poor condition or if they have a charge level below 25% (specific gravity below 1.155).

Keep all metallic objects off the top of the batteries, as they may cause a short circuit. Replace worn or damaged cables and terminals.

Check the electrolyte level in each battery cell before and after charging the batteries. Never add acid to the batteries, use distilled water. Do not allow water level to fall below the battery plates. Portions of plates exposed to air will be destroyed. Do not overfill. Keep plugs firmly in place at all times.

CAUTION:

When servicing machine, avoid contact with battery acid.

WARNING:

Batteries emit hydrogen gas. Explosion or fire can result. Keep sparks and open flame away. Keep covers open when charging.

WARNING:

Wear eye protection and protective clothing when working with batteries.

WARNING:

Charge batteries in a well ventilated area.

Battery Maintenance

1. When cleaning the batteries, use a solution of baking soda and water. Do not allow the cleaning fluid to enter the battery cells, electrolyte will be neutralized.
2. Maintain the proper electrolyte level in each battery cell. If a cell should accidentally overflow, clean immediately.
3. Wipe off the top of the batteries at least once a week.
4. Test battery condition with a hydrometer at least once a week.
5. Ensure that all connections are tight and all corrosion removed.

Every 4 to 6 months, remove that batteries from the machine and clean the battery cases and battery compartment.

Maintenance

Checking Battery Specific Gravity

Use a hydrometer to check the battery specific gravity.

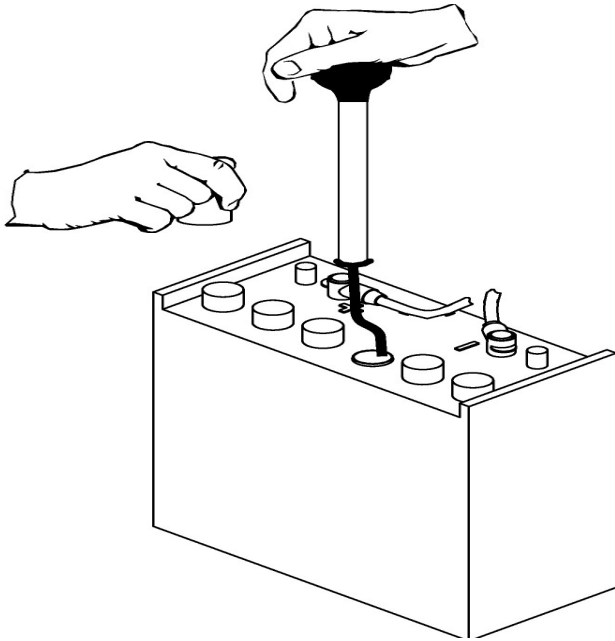

CHECKING GRAVITY

- Hydrometer Battery
- Battery

NOTE: Do not take readings immediately after adding distilled water, if the water and acid are not thoroughly mixed, the reading may not be accurate.

Check the hydrometer readings against this chart.

SPECIFIC GRAVITY @ 80 °F (27 °C)	BATTERY CONDITION
1.265	100% CHARGED
1.225	75% CHARGED
1.190	50% CHARGED
1.155	25% CHARGED
1.120	DISCHARGED

NOTE: If the readings are taken when the battery electrolyte is any temperature other than 80°F (27°C), the reading must be temperature corrected. To find the corrected specific gravity reading when the temperature of the battery electrolyte is other than 80°F (27°C): Add (+) to the specific gravity reading 0.004 (4 points), for each 10°F (6°C) above 80° (27°C). Subtract (-) from the specific reading 0.004 (4 points), for each 10°F (6°C) below 80°F (27°C).

Charging Batteries

CAUTION:

When servicing machine, avoid contact with battery acid.

WARNING:

Batteries emit hydrogen gas. Explosion or fire can result. Keep sparks and open flame away. Keep covers open when charging.

WARNING:

Wear eye protection and protective clothing when working with batteries.

WARNING:

Charge batteries in a well ventilated area.

Use a 36 volt, 20 amp maximum output DC charger which will automatically shut off when the batteries are fully charged.

1. Stop the machine in a clean, well ventilated area next to the charger.
2. Turn "OFF" machine.

FOR SAFETY: Before leaving or servicing machine; stop on level surface, turn off machine and remove key.

3. Open rear cover, unplug batteries from machine, unlatch battery tray and pull out to expose batteries.

WARNING:

Batteries emit hydrogen gas. Explosion or fire can result. Keep sparks and open flame away. Keep covers open when charging.

4. Check the electrolyte level in each battery cell. Before charging, add just enough distilled water to cover the plates. After charging is complete, add just enough distilled water to bring up the level to the indicator ring. If the water level is too high before charging, normal expansion rate of the electrolyte may cause an overflow resulting in a loss of battery acid balance and damage the machine.
5. Replace the battery caps, and leave them in place while charging.

FOR SAFETY: When charging, connect the charger to the batteries before connecting the charger to the AC wall outlet. Never connect the charger to the AC wall outlet first. Hazardous sparks may result.

6. Plug the charger connector into the battery connector. Connect the charger AC plug to a wall outlet. The charger gauge should indicate that the batteries are charging.
7. When the batteries are fully charged, disconnect the charger from the AC wall outlet, then disconnect the charger from the batteries.
8. Connect the batteries to the machine connector.
9. Check the electrolyte level. It should be up to the indicator ring. If necessary, add distilled water.
10. Close the rear cover.

Maintenance

Changing Batteries

Stop the machine in a clean area next to the charger.
Turn off machine.

FOR SAFETY: Before leaving or servicing the machine; stop on level surface, turn off machine and remove key.

1. Remove the rear cover.
2. Disconnect battery pack from machine.
3. Unlatch battery tray from machine and pull out to expose batteries.
4. Use the proper size open end wrench to disconnect main ground wire first and secure cable terminal away from batteries.
5. Disconnect main positive lead and secure cable terminals away from batteries.
6. Loosen both terminals on each jumper cable and remove one at a time.
7. Prepare a suitable site to place the batteries.

! WARNING:

Attach suitable battery lifting device and lift batteries from the machine. Batteries are a potential environmental hazard. Consult your battery supplier for safe disposal methods.

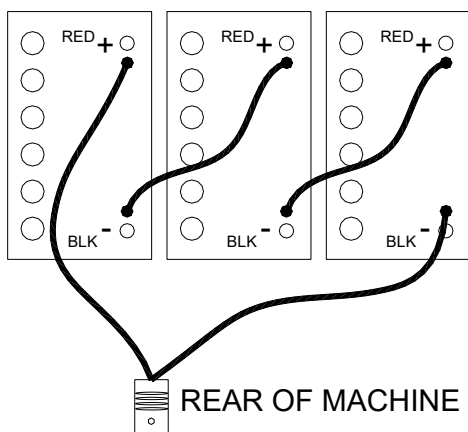

Onboard Charger (Optional)

⚠ CAUTION:

Circuit Breaker must be off before unplugging batteries.

Battery Charger Programming

For machines equipped with optional on-board charger. When replacing batteries, charger programming changes may be required. If replacing batteries with same type, (e.g. maintenance free batteries with maintenance free) no programming is required. When batteries with different type (e.g. maintenance free with wet cell), programming changes are required. Failure to make programming changes may lead to reduced battery life.



1. Remove four screws from charger mounting bracket. Lift charger out of console.
2. Peel back label on charger to access dip switches.
3. Change switches to correct battery type.

	DIP 1	DIP 2	DIP 3	DIP 4	DIP 5	DIP 6	DIP 7	DIP 8
LEAD ACID	OFF	ON	ON	ON	OFF	ON	ON	OFF
DISCOVER AGM	ON	OFF	OFF	OFF	OFF	ON	ON	OFF

4. Replace charger label and lower charger back into console. Tighten four screws to secure mounting bracket to console.

Maintenance

Lithium Battery (Optional)



This product must be recycled and is made of recycled products

Chemical Risk

!WARNING:

Lithium batteries are chemical risk if mis-operated, mishandled or abused.

Do:

- Do protect terminals from short circuit before, during, and after installation
- Do wear electrically insulated gloves
- Do use electrically insulated tools
- Do wear eye protection
- Do wear safety toe boots / shoes
- Do handle battery carefully
- Do secure battery safely
- Do always assume battery terminals are energized

Do Not:

- Do not lift or carry the battery during usage or operation
- Do not operate or store battery outside of operating limits
- Do not short circuit battery
- Do not puncture battery
- Do not expose battery to flames, or incinerate
- Do not open battery case or disassemble battery
- Do not wear rings, watches, bracelets or necklaces when handling or working near battery
- Do not drop or crush battery
- Do not lift battery by the terminal cables
- Do not vibrate battery
- Do not expose battery to water or other fluids
- Do not expose battery to direct sunlight
- Do not dispose of battery
- Do not connect with other types of batteries
- Do not expose battery to high temperatures
- Do not install with other battery types or brands

Transportation

If the battery is not installed in equipment, it must be transported in the original package or equivalent.

Batteries are tested according to UN Handbook of Tests and Criteria, part III, sub section 38.3 (ST/SG/AC. 10/11/ Rev.5). For transport, the batteries belong to category UN3480, Class 9, Packaging Group II.

Operating Limits

The battery should not be operated outside these operating limits:

Operating Limits	12-36-6700
Continuous Charge Current	150A
Continuous Discharge Current	150A
Charge Voltage	40.8 V
Operating Voltage (Min / Max)	33.6 V / 43.8 V
Charge Temperature (Min / Max)	0°C / 45°C (32°F / 113°F)
Discharge Temperature (Min / Max)	-20°C / 50°C (-4°F / 122°F)
Storage Temperature (Min / Max)	-20°C / 45°C (-4°F / 113°F)

CAUTION:

Do not install batteries in series. Select the appropriate AES battery model for the voltage of your system.

NOTE: Intentional bypassing of BMS to operate battery outside maximum and minimum limits voids warranty.

Fuse

Fuse provides back-up over-current protection.

Fuse Replacement

A blown fuse requires service from a qualified technician. Contact your Discover supplier for more information.

Maintenance

Handling

! WARNING:

Read Safety Section before installing the battery.

- Battery should be off.
- Battery cables should be disconnected.
- Battery terminals should be protected.
- Battery handle should be used to lift battery.
- Battery should be handled by two people or mechanical lift equipment.
- Do not lift or carry the battery during usage or operation.

Installation - Single Battery

! WARNING:

Read Safety Section before installing the battery.

Tools

- Insulated tools sized to match nuts, bolts and cables in use
- Voltmeter
- Post cleaner and wire brush
- Personal protective equipment

Securing Battery

- Battery can be strapped in place with non-conductive nylon straps
- Battery may have hold down brackets at the base of the battery

Installation

- Check that battery is switched off
- If battery circuit has disconnect, open disconnect to isolate battery
- Clean cable connections. Broken, frayed, brittle, kinked or cut cables should be replaced
- Install and secure new battery. Be careful not to ground the terminals to any metal mounting, fixture, or body part
- Connect battery cables. Connect ground cable last to avoid sparks
- Recommended terminal torque is 9.0 Nm (6.64 ft-lb)
- Close circuit disconnect (if open)
- Turn battery switch on

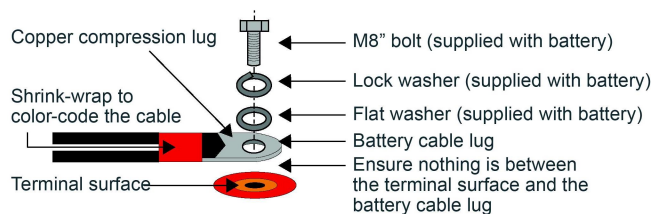

NOTE: All cable ends must be connected to battery terminals without any washers between terminal bushings and cable ends.

Terminal burnout is caused by:

- Discharge currents exceeding allowable limits
- Improper cable installation
- Improper cable sizing
- Improper terminal torque

NOTE: Without exception, product experiencing terminal burnout will not be warranted.

Operation

NOTE: Review operating limits.

On-Off

- To turn the battery on press and hold switch for 2-3 seconds
- To turn the battery off press and hold switch for 2-3 seconds



Charging

Before operating the charger make sure to read and understand the instructions that come with the charger. Never attempt to charge a battery without first reviewing and understanding the instructions for the charger being used

⚠ CAUTION:

Always make sure the chargers charging curve meets the battery's charging requirement; never charge a visibly damaged battery; never charge a frozen battery.

1. Connect the charger leads to the battery.
2. Make sure that the charger lead, both at the charger and the battery side, connections are tight.
3. Turn the charger on.
4. Turn the battery on (if required).

⚠ CAUTION:

NOT ALL CHARGERS ARE CAPABLE OF CHARGING LITHIUM BATTERIES! During system design CONFIRM that your chosen charger is not capable of transient spikes that exceed the published MAXIMUM TERMINAL RATINGS of the battery

Discharging

- Turn on battery.
- Turn on load

NOTE: Do not discharge battery below recommended minimum operating voltages.

NOTE: Do not discharge battery at rates greater than recommended operating currents.

Storage

Systems should be stored out of direct sunlight under the following temperature conditions:

Minimum Storage Temperature	-20°C / -4°F
Maximum Storage Temperature	45°C / 113°F

System should be put into storage at 80% SOC and checked monthly to ensure the system SOC (state of charge) does not fall below 20%/ At 2-% SOC the battery will self discharge in approximately 2 months.

Protection & Faults

- BMS (battery management system) generates faults when maximum operating limits are reached.
- BMS sounds a buzzer when fault limits are triggered.
- BMS monitors the following information for faults and warning:
 - Cell module voltage
 - Battery current
 - Battery temperature

Faults & Corrective Actions

In the event of a fault the BMS (battery management system) will sound an audible buzzer warning and the system will shut off after a 120 second delay.

FAULT LEVELS	
Parameter	Trigger Point
High Temperature	60°C / 140°F
High Voltage	3.7 V in any cell module
Low Voltage	2.5 V in any cell module
Over Current	150 A

Maintenance

CORRECTIVE ACTIONS	
High Temperature	Stop discharge or charge Leave the battery to cool
Low Temperature	Stop discharge or charge
High Voltage	If charging, stop charge
Low Voltage	Do not discharge the battery. Any discharge current detected will force the battery into Low Voltage Fault The user can charge the battery in Low Voltage Recovery If no charge current is detected within 2 minutes, the BMS will turn off the battery
Over Current	Reduce current
Low SOC	Stop discharge Charge the battery

Service & Maintenance

Batteries should be carefully inspected on a regular basis in order to detect and correct potential problems before they can do harm. This routine should be started when the batteries are first received.

Inspection

- Look for cracks in the case
- Check the battery, terminals and connections to make sure they are clean, free of dirt, fluids and corrosion
- All battery cables and their connections should be tight, intact, and NOT broken or frayed
- Replace any damaged batteries
- Replace any damaged cables
- Check torque on terminal bolts

Troubleshooting

Battery Won't Turn On:

Symptom	Does the battery turn on for a short time, then turn itself off?
Description	The battery is likely in a low voltage or low SOC.
Action	Connect to charger and turn on the battery.

Symptom	Was the battery left on or stored for extended periods of time?
Description	The battery will turn itself off at 5% SOC. If left sitting at a low SOC, the battery may have discharged itself completely and cannot be used.
Action	Do not use. Replace and recycle.

Changing Battery

Stop the machine in a clean area. Turn off machine.

FOR SAFETY: Before leaving or servicing the machine; stop on level surface, turn off machine and remove key.

1. Remove the rear cover.
2. Disconnect battery from machine.
3. Unlatch battery tray from machine and pull out to expose battery.
4. Use the proper size open end wrench to disconnect main ground wire first and secure cable terminal away from battery.
5. Disconnect main positive lead and secure cable terminals away from battery.
6. Prepare a suitable site to place the battery.

! WARNING:

Attach suitable battery lifting device and lift battery from the machine. Batteries are a potential environmental hazard. Consult your battery supplier for safe disposal methods.

Recycling and Disposal

Batteries must not be mixed with domestic or industrial waste. Discover's Advanced Energy Systems are recyclable and must be processed through a recognized recycling agency or dealer. Please contact Discover® or your servicing dealer for details.



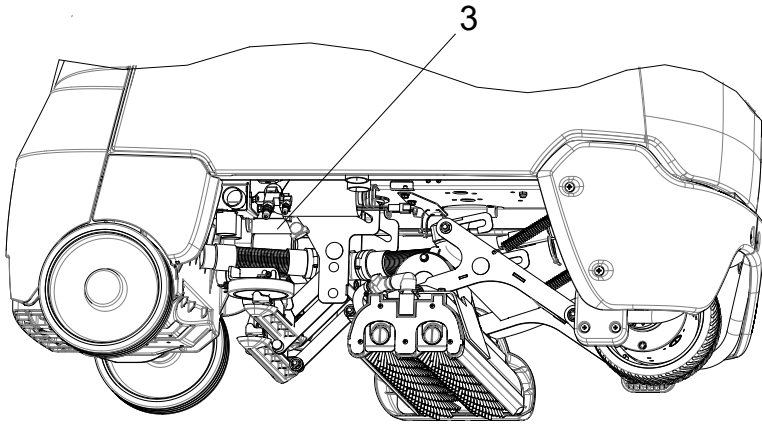

WITH PUMP OFF-AISLE OPTION

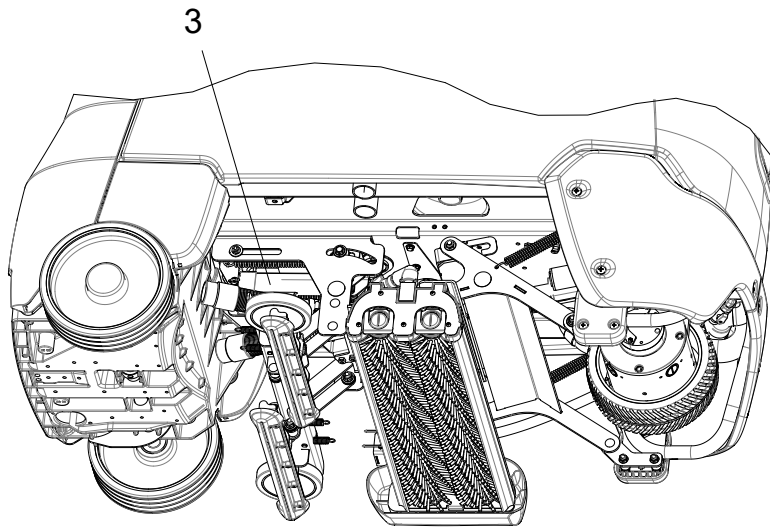

WITHOUT PUMP OFF-AISLE OPTION

Vacuum Shoes

- 1. Vacuum Shoes
- 2. Vacuum Shoe Release
- 3. Vacuum Shoe Lift Actuator

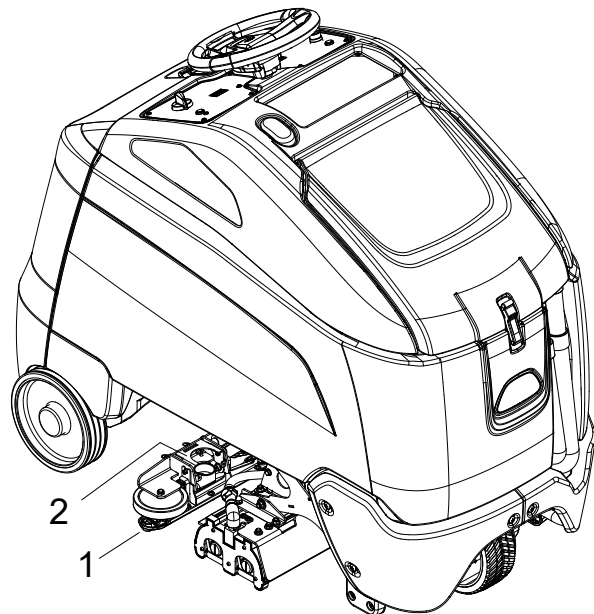

Vacuum Shoes

The dual offset vacuum shoes are designed to extract soiled solution from the carpet. The plastic vacuum shoe glides minimize damage to carpet and flooring.

Maintenance

The vacuum shoes should be removed and cleaned daily to ensure maximum solution recovery.

Vacuum Shoe Removal and Cleaning

1. Make sure the vacuum shoes are in the raised position and the key is off.
2. Press the gray latch to release the vacuum shoe from the mounting bracket.
3. Twist the hose out of the clear cover.
4. Rotate the left and right latches to separate the clear cover from the glide base.
5. Inspect and clean both parts.
6. Reinstall glide base and clear cover.
7. Check to be sure foam gasket is seated properly.
8. Repeat for other vacuum shoe.

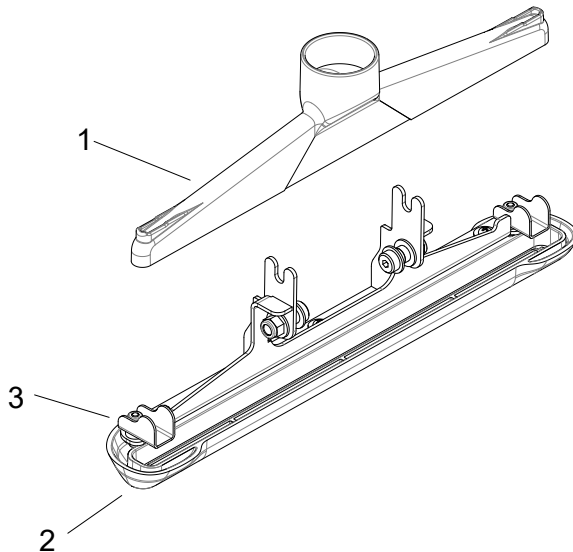

1. Vacuum Shoe Cover
2. Vacuum Shoe Wiper Base
3. Vacuum Shoe Latch

Vacuum Shoe Lift Actuator Removal/Replacement

FOR SAFETY: Before leaving or servicing machine, stop on a level surface and turn off the machine.

Removal:

1. Make sure the vacuum shoes are in the raised position and the machine key switch is off.
2. Unplug the actuator cable from the machine harness.
3. Cut and remove the two cable ties securing the actuator cable to the machine.
4. Remove the cotter ring pin, washer, two spacers, and clevis pin from each end of the actuator. Note the position of all parts before removing to make re-assembly easier.
5. Remove the actuator from machine.

Installation:

1. Fully extend the actuator before installing it into machine. With the machine key switch off, plug the actuator into the machine harness. Turn the function mode dial to the slow transport position and turn the key switch on. Wait for the actuator to fully extend and then turn the key switch off. Be careful that the actuator does not interfere with surrounding parts as it is extending.
2. Install the moving end of the actuator, clevis pin, two spacers, washer, and cotter ring pin into the front bracket.
3. Install the fixed end of the actuator, clevis pin, two spacers, washer, and cotter ring pin into the rear bracket.
4. Route the actuator cable and secure it to the machine in two places using new cable ties.
5. Check the linkage operation. Turn the key switch on and turn the function mode dial to the C position. Verify the vacuum shoes lower to the ground. Turn the function mode dial to the slow transport position and verify the vacuum shoes move to the raised position.

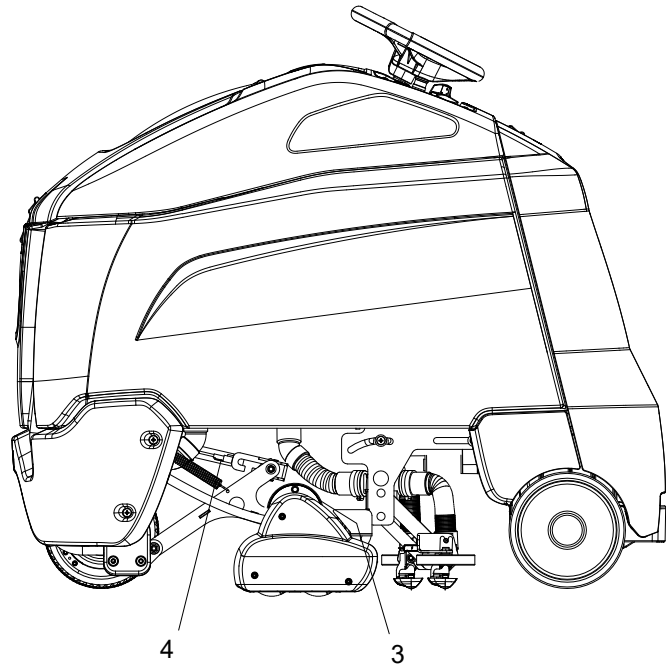
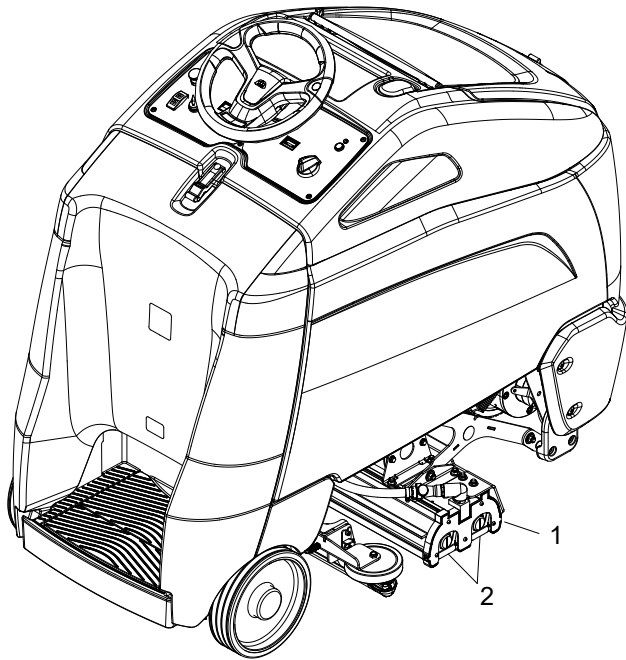

Brush Deck

1. Brush Deck
2. Brush Release Clips
3. Brush Motor
4. Brush Deck Lift Actuator

Brush Deck

The dual counter-rotating cylindrical brushes are designed to scrub and groom the carpet.

Maintenance

Scrub brushes should be inspected and cleaned daily. Scrub brushes should be exchanged front to back every 50 hours to ensure even wear. Scrub brushes should be replaced as a set when bristle length wears to the height of yellow PerformAlert™ bristles.

Scrub Brush Removal

The scrub brushes are removed from the right side of the machine.

1. Raise the scrub deck to the storage position.
2. Pull out on the bottom of the retaining clip.
3. The brush assembly and end cap should drop down. Then pull the brush down far enough to clear the bottom of the housing.
4. Pull brush out with a rocking motion to free brush from drive hub.

Bearing Cleaning

1. Remove bearing cap from end of brush.
2. Clean cap and bearings.

Maintenance

Brush Deck Motor

Remove Brush Deck

1. Remove both halves of bumper
2. Raise brush deck
3. Disconnect springs from deck lift arms
4. Lower brush deck
5. Turn off machine
6. Turn off ball valve
7. Remove solenoid cover (1) screw and associated hardware
8. Unplug harness from brush motor and solenoid
9. Remove shaft cover (4) nuts & washers
10. Loosen hose clamp and remove valve-to-solenoid hose from solenoid
11. Remove (2) bolts & hardware that fasten deck to lift linkage
12. Push loose deck towards rear of machine until lift linkage arm clears motor shaft
13. Angle deck and slide out left side of machine
14. Reverse to reassemble

Replace Brush Deck Motor

1. Remove brush deck from machine
2. Cut cable tie that secures motor cable to brush deck.
3. Remove two (2) nuts to free right rear motor mounting bracket from deck.
4. Remove six (6) motor mount bracket face screws
5. Remove rear mounting bracket
6. Remove motor with attached coupler hub, leaving front motor mounting bracket still attached to deck
7. Remove coupler hub (1 set screw) from old motor for reuse
8. Reverse process to reassemble with new motor

Scrub Deck Actuator Removal/ Replacement

FOR SAFETY: FOR SAFETY: Before leaving or servicing machine, stop on a level surface. Turn off machine.

1. Lower deck
2. Turn off machine
3. Remove both halves of bumper
4. Unplug actuator
5. Remove cotter pin and clevis pin at deck end of actuator
6. Remove screw & lock washer at front end of actuator (it may be necessary to swing actuator end up to underside of machine frame to gain access to screw)
7. Remove actuator along with plastic spacer washer
8. To reassemble with new actuator:
 - a) Attach actuator front end to bracket with screw, lock washer & plastic spacer
 - b) Plug in actuator
 - c) Turn rotary switch to A1 to extend actuator
 - d) Turn off machine when extended
 - e) Attach rear end of actuator with clevis and cotter pin.
9. Reinstall both halves of bumpers.

Replace Pump - Off-Aisle Option

1. Unplug pump from harness.
2. Remove (3) nuts & washers that secure pump mounting plate assembly to underside of machine frame.
3. Move pump assembly to workbench.
4. Remove fittings from pump.
5. Remove (4) pump mounting nuts & washers.
6. Cut cable tie that secures pump harness to plate.
7. Slide pump from mounting studs.
8. Install new pump, secure with washers & nuts; tighten so 3 threads are exposed beyond nut disassembly.
9. Assemble fittings in reverse order from disassembly.
10. Use pipe sealant on brass fittings; Use Teflon tape on plastic fittings AND brass fittings assembling into plastic (pump); make sure fittings are tight.
11. Cable tie wires to pump & plate.
12. Install assembly to underside of machine frame.
13. Plug in pump to harness.

⚠ WARNING:

Do not use a pressure washer to clean around the brush motors. Use tap pressure only.

Brush Motor Carbon Brush Replacement

1. Scribe alignment mark on motor barrel to motor cap. Remove two bolts.

2. Remove end cap from motor.

NOTE: Motors contain two wave washers in cap. Do not lose these.

3. Release brush from spring tension. Remove screw connecting brush wire lead to brush holder. Clean brush holder to ensure free movement.

4. Retract spring and install new brush. Install connector screw and lead.

5. When all new brushes are installed. Place all in retracted position, held into brush holder by spring tension.

6. Carefully place end cap onto bearing on motor shaft.

NOTE: Use care to ensure wave washer alignment.

7. With end cap in partially installed position, release all brushes to contact position with motor commutator.

NOTE: Failure to ensure all brushes are released will result in motor failure.

8. Reset end cap and realign with scribe marks on motor barrel. Reinstall the two attach bolts from cap into base.

9. Maintain alignment between motor barrel base and cap.

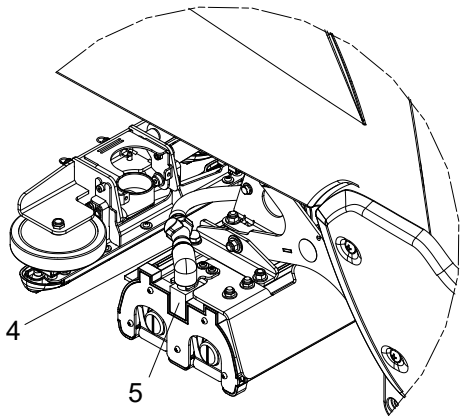

VIEW A

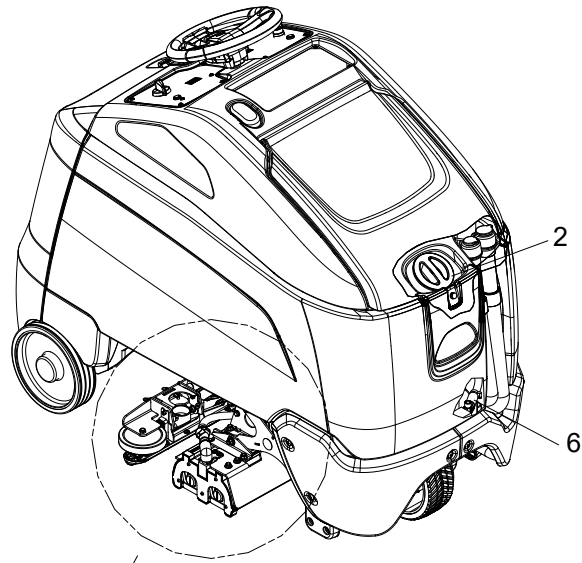

SEE VIEW A

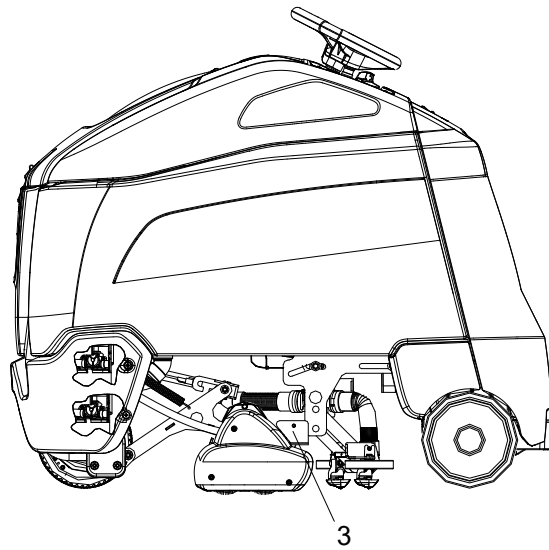
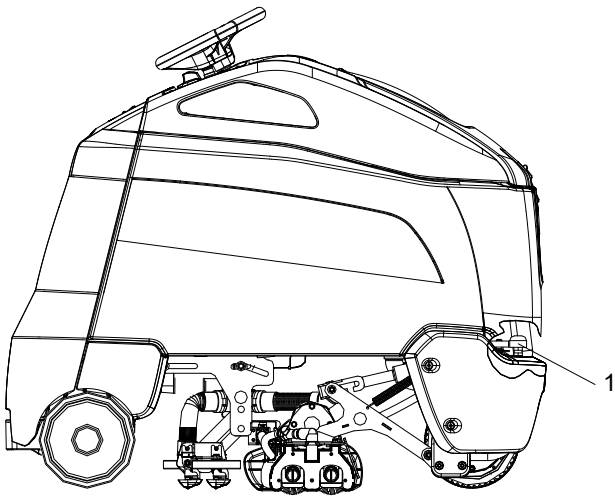

Solution

1. Strainer
2. Solution Cap
3. Solenoid Valve
4. Manifold Quick Release
5. Manifold
6. Ball Valve

Solution Strainer

Located in bottom of tank. Protects system from debris.

Solenoid Valve

The solenoid valve is mounted on the back of the scrub deck, on left side. The solenoid valve opens and closes to meter the correct amount of solution to the scrub deck.

The solenoid valve shuts off solution flow to scrub deck whenever scrubbing stops.

To repair or replace solenoid valve:

1. Remove 1 screw to remove sheet metal cover.
2. Disconnect 2 electrical connectors.
3. Loosen hose clamps for both hoses.
4. Pull both hoses off valve.
5. Remove 2 screws securing valve to mounting bracket.
6. Reverse process to install.

Solution Manifold

The solution manifold supplies solution equally along the length of the brush. The manifold can be removed by releasing the quick disconnect at the right side of the brush deck. The manifold should be cleaned daily for best results.

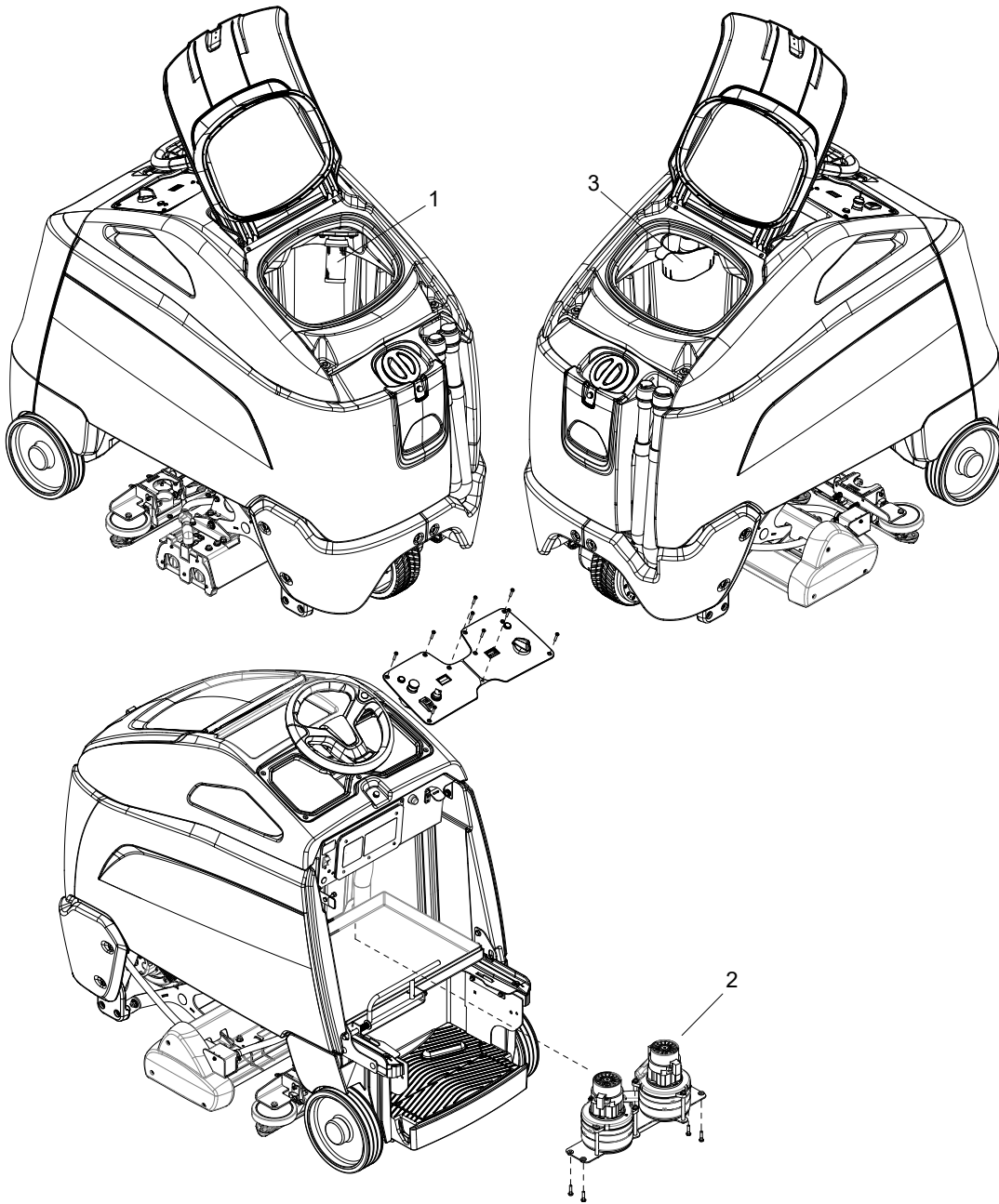

Vacuum

- 1. Recovery Tank Float Shut-off
- 2. Vacuum Motors
- 3. Debris Bin

Recovery Tank Float Shut-off

When water is no longer being vacuumed from the floor and the vacuum fan is operating, the ball float has engaged. The vacuum motor will not vacuum water with recovery tank full. The recovery tank must be drained.

1. The float shut-off screen can be cleaned in or out of the machine.
2. To clean the float shut-off while it is inside the machine wipe material off screen then rinse. Check that the ball is also clean and moves freely.
3. To remove the float shut-off, grasp the screen with one hand and the connected tube with the other. Tilt and pull the float screen assembly to pull it off the barb on the tube.
4. To install, place one hand on the tube, and then tilt and push the float screen assembly over the barb on the tube.

FOR SAFETY: Before leaving or servicing machine, stop on a level surface, turn off machine and disconnect power.

To Repair or Replace Vacuum Motors

1. Remove rear cover from machine.
2. Remove 9 screws and remove upper control panel.
3. Disconnect electrical connectors from the vacuum motors.
4. Remove batteries from machine.
5. Remove 4 screws mounting vacuum motor assembly to console.
6. Lower vacuum motor assembly down into battery compartment.
7. Remove 3 screws mounting the vacuum motor to the plenum.
8. Disconnect the vacuum hose from the vacuum motor exhaust.
9. Reverse the process to install.

Vacuum Motor Carbon Brushes

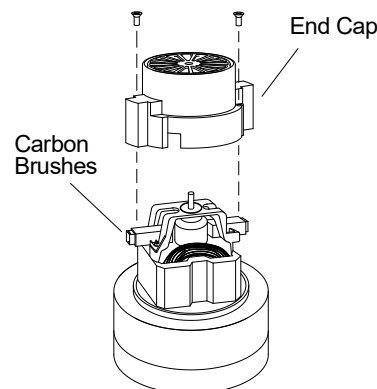

If armature commutator is grooved, extremely pitted or not concentric, the motor will need to be replaced or sent to a qualified service center.

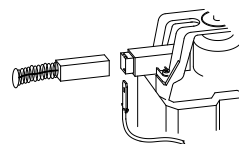

Important:
These brushes wear quicker as the length shortens due to increased heat. Spring inside brush housing will damage motor if brushes are allowed to wear away completely.

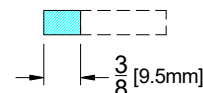

Periodically check the length of the carbon brushes. Replace both carbon brushes when either is less than 3/8" (9.5mm) long.

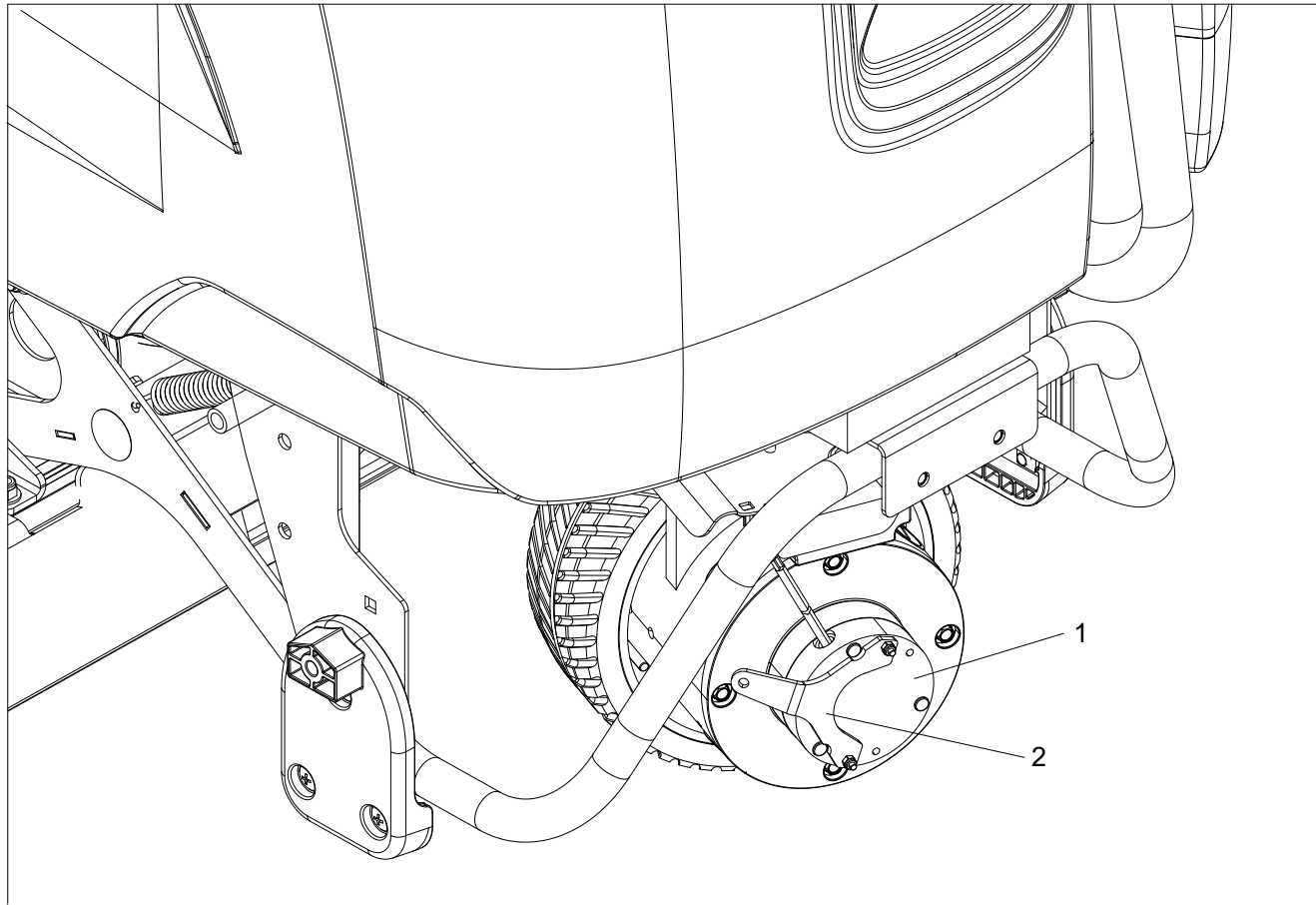

Drive Motor

- 1. Drive Motor
- 2. Parking Brake

Electric Parking Brake Engagement

FOR SAFETY: Before leaving or servicing machine, stop on a level surface, turn off machine and remove key.

Electric Brake Engagement

This machine is equipped with an electric parking brake.

The brake automatically engages and keeps the machine from moving whenever the operator steps off the platform or when emergency stop is engaged.

The brake has a mechanical over-ride that can be engaged so machine can be pushed or towed (slowly).

To disengage brake:

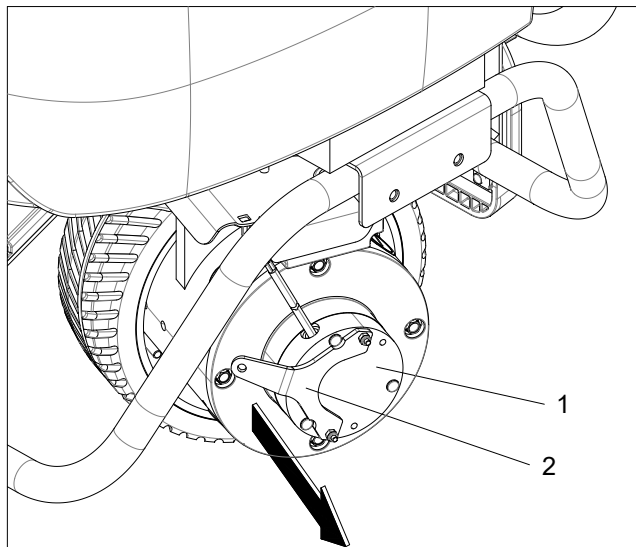

1. Pull lever away from brake housing.
2. Insert material to hold brake lever in place.

! WARNING:

Do not operate machine with brake disengaged.

Drive Motor Carbon Brush Replacement

! WARNING:

Do not use a pressure washer to clean around the motors. Use tap pressure only.

FOR SAFETY: Before leaving or servicing machine, stop on a level surface, turn off machine and remove key.

1. Disconnect batteries from machine.
2. Disconnect the electrical connection to the traction motor.

Maintenance

Transporting

Pushing Machine

The machine may be pushed for short distances at speeds not to exceed 5 mph. Be careful to avoid damaging machine. The machine may be pushed by hand from the rear.

NOTE: To avoid damage caused by regenerative voltage, disconnect traction motor before towing or pushing machine.

Machine Tie-Downs

There are four tie down points, two on the front wheel guards, and two on the rear axle located on either side of the foot box.

Preparation for Loading/Unloading Trailer

Scrub head must be in the up position before loading.

When transporting the machine on a trailer or in a truck, in addition to using tie-downs, be sure to set the parking brake, and block the tires to prevent the machine from rolling

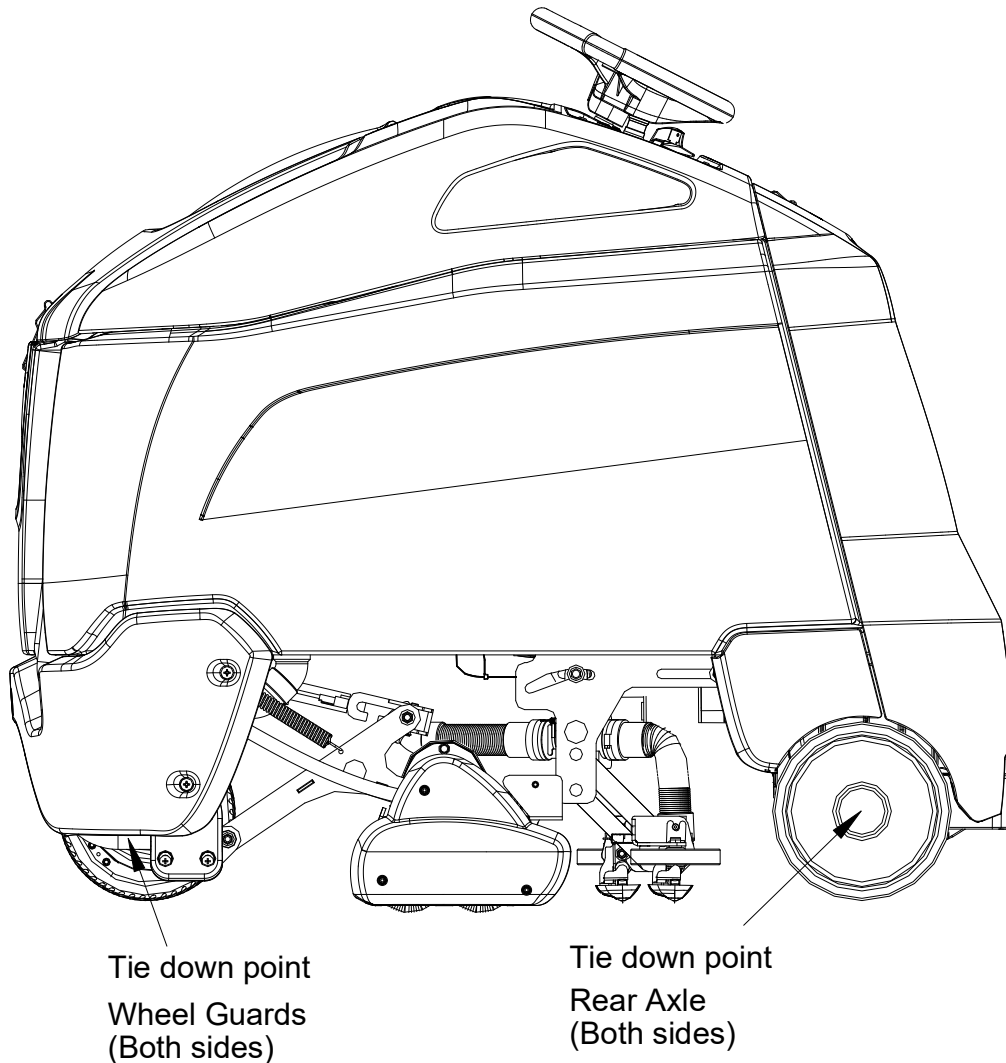

Circuit Protection

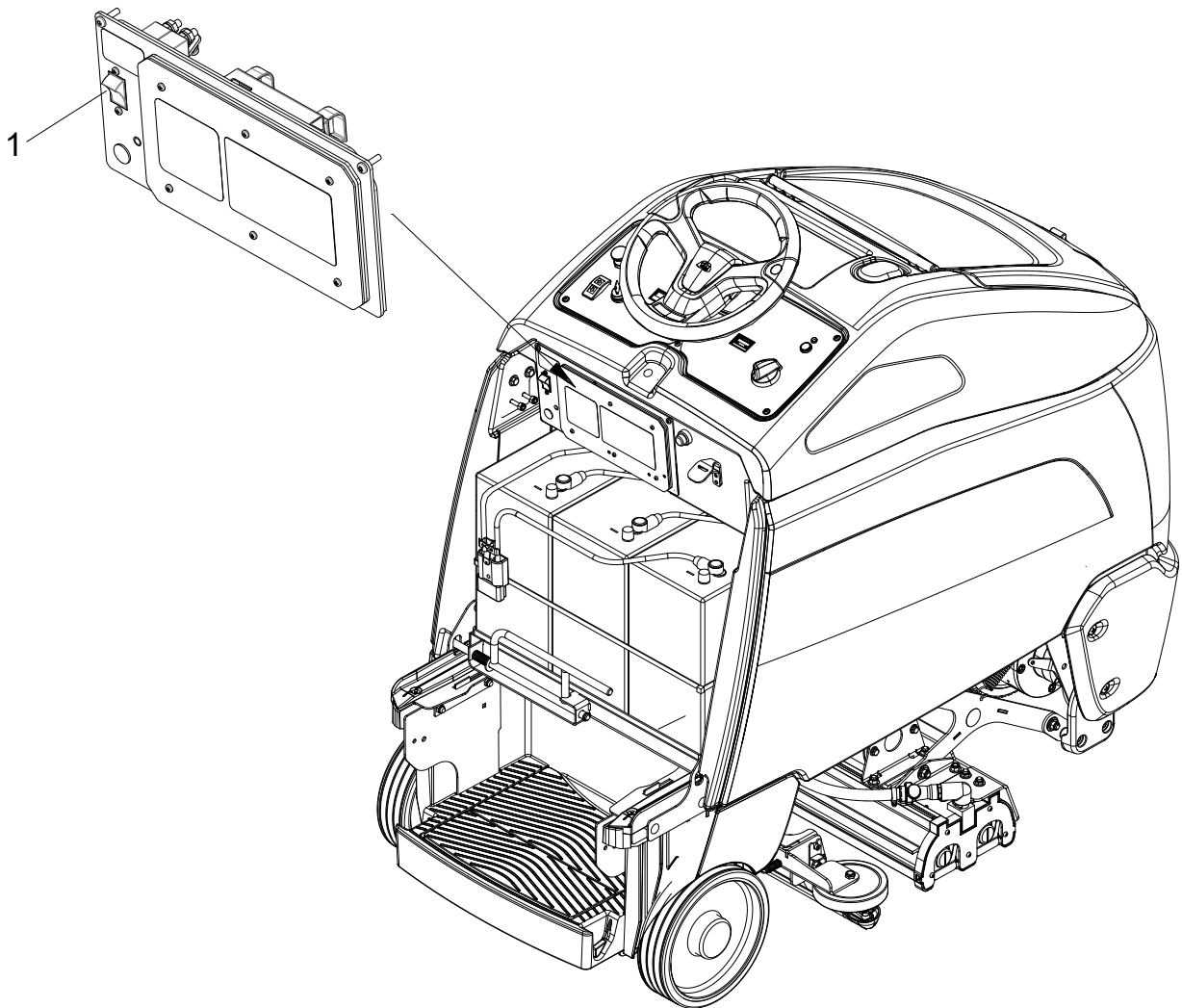

Circuit Breakers

1. MAIN CIRCUIT BREAKER

Interrupts the flow of power from batteries in the event of an electrical overload. When the circuit breaker is tripped, it can be reset by pressing the toggle switch. If the circuit breaker continues to trip, the cause of the electrical overload must be corrected.

Maintenance









Troubleshooting

PROBLEM	CAUSE	SOLUTION
No power to machine	Battery disconnected	Check all battery cable connections
	Emergency shut-off activated	Reset
	Battery cables corroded	Clean connections
	Faulty key switch	Replace switch
	On board charger plugged in	Unplug and stow cord
	Main circuit breaker tripped	Reset circuit breaker
Little or no propel	Low battery charge	Charge batteries
	Machine turned on with pedal not in neutral position	Allow pedal to return to neutral. Restart.
	Tripped circuit breaker	Reset circuit breaker
	Wheels spin	Decrease brush pressure
	Controller overheated	Allow cool down period
	Loose motor connection	Check wires and connections from controller to motor
	Faulty throttle circuit or potentiometer	Check wires and connections from and potentiometer resistance
	Faulty drive reset circuit or switch	Check wires, connections and switch
Faulty platform circuit or switch	Check wires, connections and switch	
Machine does not change speeds	Faulty speed control circuit or switch	Check wires & connections
Forward speed only	Faulty forward/reverse circuit	Check wires & connections
Reverse speed only		
Poor or no water pickup	Debris caught on vacuum shoe	Remove debris
	Damaged vacuum shoe	Replace vacuum shoe
	Vacuum hose clogged	Clear obstruction from hose
	Vacuum hose disconnected from vacuum shoe	Reconnect vacuum hose
	Recovery tank float system dirty	Clean float system
	Recovery tank not sealed	Latch recovery tank lid to tank. Replace damaged gaskets
	Float-ball shut-off engaged, tank full	Empty recovery tank
	Foam filling recovery tank	Empty recovery tank. Use less or different detergent. Use defoamer.
	Vacuum shoe not contacting the floor correctly	Check vacuum shoe latch engagement
	Vacuum shoe clogged	Take vacuum shoe apart and clean
	Vacuum shoe not recovering efficiently	Verify gasket between cover and glide of vacuum shoe is installed correctly and not damaged.

PROBLEM	CAUSE	SOLUTION
Vacuum motor does not run, or runs slowly	Faulty vacuum circuit or switch	Check wires connections and motor
	Worn vacuum motor brushes	Replace brushes, check commutator
Vacuum shoes will not go up/down	Faulty circuit or actuator	Check wires, connectors and actuator
Poor scrubbing performance	Debris caught in scrub brushes	Remove debris
	Worn brushes	Replace brushes
	Low battery charge	Charge batteries
Little or no solution flow to the floor	Solution tank empty	Fill solution tank
	Solution strainer plugged	Clean solution strainer
	Solution system plumbing obstructed	Clear obstruction from plumbing
	Solution solenoid valve obstructed or faulty.	Repair or replace solenoid valve
	Clogged or dirty manifold	Clean solution manifold
Brush motors do not run, or run slowly	Low battery charge	Charge battery
	Faulty brush circuit or motor	Check wires, connections and motor
	Worn brush motor brushes	Replace brushes, check commutator
Scrub deck goes down, then raises	Faulty actuator circuit or actuator	Check wire connections and actuator
Optional Off-Aisle pump runs, but no solution sprays from tool nozzle	Clogged spray nozzle.	Replace Nozzle
	Machine solution tank empty.	Fill solution tank
	While in off-aisle mode with wand/hand tool trigger squeezed, machine was turned off by key switch, or emergency stop switch.	Disconnect & reconnect solution supply hose to pump (relieves suction pressure buildup)
Optional Off-Aisle pump will not run	Pump harness in-line fuse blown	Replace fuse
	Fuse cap or fuse making bad connection	Remove fuse cap and fuse, reinstall

Maintenance

Controller Fault Codes

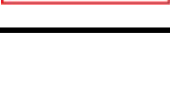
ERROR CODE DELUXE	PROBLEM	SOLUTION
1 Bar 	TRACTION MOTOR AND CONTROLLER ERROR	THE BATTERY NEEDS CHARGING OR THERE IS A BAD CONNECTION FROM THE BATTERY TO THE TRACTION CONTROLLER. CHARGE BATTERY OR CALL FOR SERVICE AND HAVE TECHNICIAN CHECK WIRING.
2 Bar 	TRACTION MOTOR DISCONNECTED	THE TRACTION MOTOR HAS A BAD CONNECTION. CALL FOR SERVICE AND HAVE TECHNICIAN CHECK WIRING.
3 Bar 	TRACTION MOTOR SHORT CIRCUIT	THE TRACTION MOTOR HAS A SHORT CIRCUIT TO THE BATTERY. CALL FOR SERVICE AND HAVE TECHNICIAN CHECK FOR SHORT CIRCUIT.
4 Bar 	AUX FAULT or ACTUATOR (DECK or SQUE) OVERCURRENT	CALL FOR SERVICE AND HAVE TECHNICIAN CHECK AUX OUTPUT DEVICES AND ASSOCIATED WIRING.
5 Bar 	VACUUM MOTOR TRIP	THE VACUUM MOTOR HAS EXCESSIVE CURRENT. CALL FOR SERVICE AND HAVE TECHNICIAN CHECK FOR SHORT CIRCUIT OR OTHER DAMAGE.
6 Bar 	BRUSH MOTOR TRIP	THE BRUSH MOTOR HAS EXCESSIVE CURRENT, CALL FOR SERVICE AND HAVE TECHNICIAN CHECK FOR SHORT CIRCUITS, PADS OR OTHER DAMAGE.
7 Bar 	THROTTLE TRIP ERROR	THE THROTTLE IS DEFLECTED OR ASSOCIATED WIRING HAS A BREAK OR SHORT CIRCUIT. CALL FOR SERVICE AND HAVE TECHNICIAN CHECK THROTTLE AND ASSOCIATED WIRING.
8 Bar 	CONTROL SYSTEM TRIP	THE TRACTION CONTROL SYSTEM IS IN ERROR. CALL FOR SERVICE AND HAVE TECHNICIAN CHECK ALL CONNECTIONS TO THE CONTROLLER.
9 Bar 	SOLENOID BRAKE	THE BRAKE SOLENOID HAS A BAD CONNECTION. CALL FOR SERVICE AND HAVE TECHNICIAN CHECK CONNECTIONS TO THE BRAKE.
10 Bar 	HIGH BATTERY VOLTAGE	EXCESSIVE BATTERY VOLTAGE, CALL FOR SERVICE AND HAVE TECHNICIAN CHECK BATTERY CONDITION.

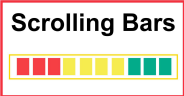
ERROR CODE DELUXE	PROBLEM	SOLUTION
 <p>Scrolling Bars</p>	MACHINE IS NOT REPORTING TO KÄRCHER FLEET	MACHINES WITH KÄRCHER FLEET SUPPORT, CALL FOR SERVICE. MACHINES WITHOUT KÄRCHER FLEET SUPPORT, NO ACTION REQUIRED.

Suggested Spare Parts

