



SERIES

DC-Powered Rooftop AC Units

X Series Operation Guide

48V | 24V | 12V

Version 1.2-112923

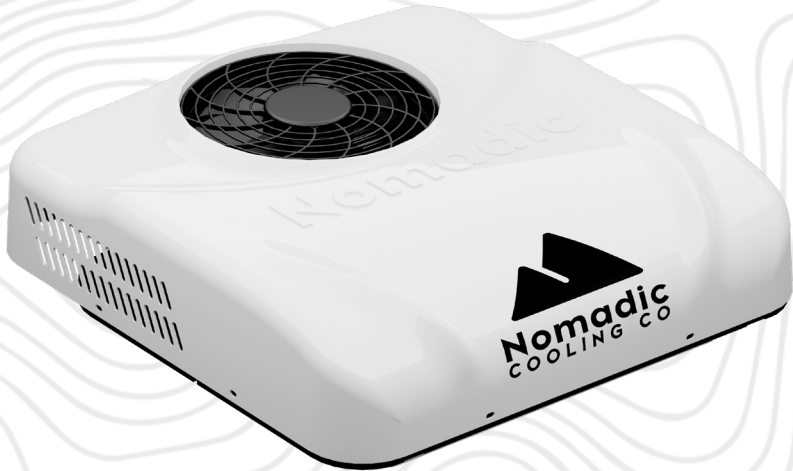

Nomadic
COOLING CO

16680 N 51st Ave Units 4 & 5
Glendale, AZ 85306
(480) 576-2489

www.NomadicCooling.com/Support

TABLE OF CONTENTS

IMPORTANT SAFETY INSTRUCTIONS.....	2
CONTROL PANEL LEGEND	3
REMOTE CONTROL DESCRIPTION	4
COMMON FAULT CODES	5
MAINTENANCE AND DISCLAIMERS	6
DIMENSIONS.....	7
CONTACT INFORMATION	7
WARRANTY POLICY.....	8
RETURNS, CANCELLATIONS AND MISSING ITEMS	9

Keep a record of the following information:

Model No. NC-X² Rooftop AC | 48
 NC-X³ Rooftop AC | 24
 12 Volt

Serial No. _____

Date Purchased _____

Installed By _____



EMBARK ON YOUR JOURNEY WITH CAUTION: YOUR SAFETY MATTERS

Prioritize safety as you venture forth into this remarkable expedition – a fusion of Nomadic’s pioneering essence and your intrepid spirit, where your welfare remains the North Star guiding every step of the way. To ensure you set forth fully equipped, we strongly advocate engaging in the training courses offered by Nomadic Cooling. These courses are designed to empower you with the skills needed to properly install and maintain your X Series rooftop AC unit. Navigate this path with assurance, relying on the comprehensive installation and operation instructions as your navigational aids. These valuable directives contain essential warnings and notes, providing a safeguard for your installation.

Improper installation, operation or maintenance of your X Series air conditioner may cause adverse consequences, including damage to vehicle and AC unit components. Read and comply with all warnings and notes in these installation and operation instructions of this product. Only Nomadic’s original accessories are allowed.

To guarantee the best cooling performance, cool down cabin via the vehicle’s original AC system before engaging the X Series AC unit for stationary use.



16680 N 51st Ave Units 4 & 5
Glendale, AZ 85306
(480) 576-2489

www.NomadicCooling.com/Support

Get social with us!



@nomadiccooling

CONTROL PANEL LEGEND

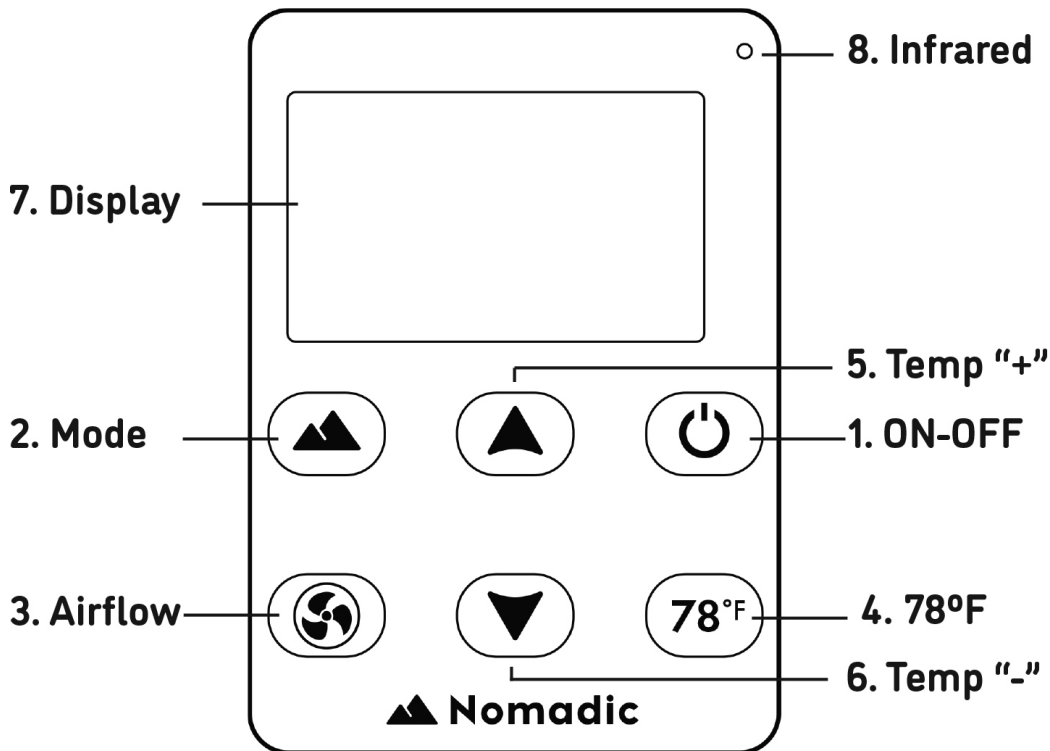

- 1. ON-OFF:** Press to switch the device ON or OFF.
- 2. Mode:** Tap the mode button to switch between modes: Auto, Power (MAX), ECO, Fan, Sun (same as Auto).
Press and *Hold* the mode button to cycle through the following settings:
 - Low Voltage Cutoff
 - High Voltage Cutoff
 - Maximum Voltage
 - Temp In
 - Temp Out
 - Error Codes
- 3. Airflow:** Each push on this button corresponds to a cycle through 5 different airflow levels.
- 4. 78°F:** Pressing this button enables automatic management towards 78°F (Auto).
- 5. Temperature "+":** Each push of this button corresponds to the increase of 1°F of temperature.
- 6. Temperature "-":** Each push of this button corresponds to the decrease of 1°F of temperature.
- 7. Display Window:** Display temperature, airflow, voltage, error codes and ambient temperature.
- 8. Infrared Signal:** Acceptance of infrared signal from remote controller by users.

Low-Voltage Protection Function

Settings: Press and hold on "78°F" button until screen starts blinking to adjust low-voltage cutoff value via Temp "+" or "-" button. The default value is 11.4V, and can range between 9-11.5V. Long press on "78°F" button again for 5 seconds to set.

In order to ensure the usage time, it is recommended to use the battery after it is fully charged.

REMOTE CONTROL DESCRIPTION

1. **ON-OFF:** Turns unit on and off
2. **Power Mode (S)** is used for fast cooling.
3. **Eco Mode (E)** is used when resting or reading is preferred.

In **Power Mode**, the default airflow is the biggest with the manual adjustment.

In **Eco Mode**, compressor is running in low frequency, airflow is defaulted as smallest with manual adjustment.

Note: Strong recommendation for Power Mode less than 20 minutes. Long time operation will significantly shorten the duration of use.

When cabin temperature is below 30°C, Auto Mode (A) is preferred.

In different modes, users can adjust the air volume according to their needs.

4. **Timer:** Use Temp "+" or "-" to set the timer using half hour increments, for up to 10 hours. Press the timer key again to cancel the timer.
5. **Temp Query:** Cycle switching between ambient temperature and evaporator surface temperature.
6. **Voltage Query:** Displays voltage reading
7. **Temp "+":** Temperature Increase
8. **Temp "-":** Temperature Decrease
9. **Airflow "+":** Increased Air Speed
10. **Airflow "-":** Decreased Air Speed
11. **Auto Mode:** Automatically sets thermostat to 78°
12. **Mode:** Normal, ECO, Powerful
(The current product status is in the selected heating and ventilation mode, only the indoor blower works.)

Error Codes and Trouble Shooting

Failure analysis of no cooling or poor effect:

- (1) The power cord connected is too long and too thin. Poor connection at connector.
- (2) No refrigerant or insufficient refrigerant.
- (3) Eco mode is used when the temperature is too high.
- (4) Compressor or condensing fan does not work.
- (5) The evaporator or condenser is dirty or blocked.

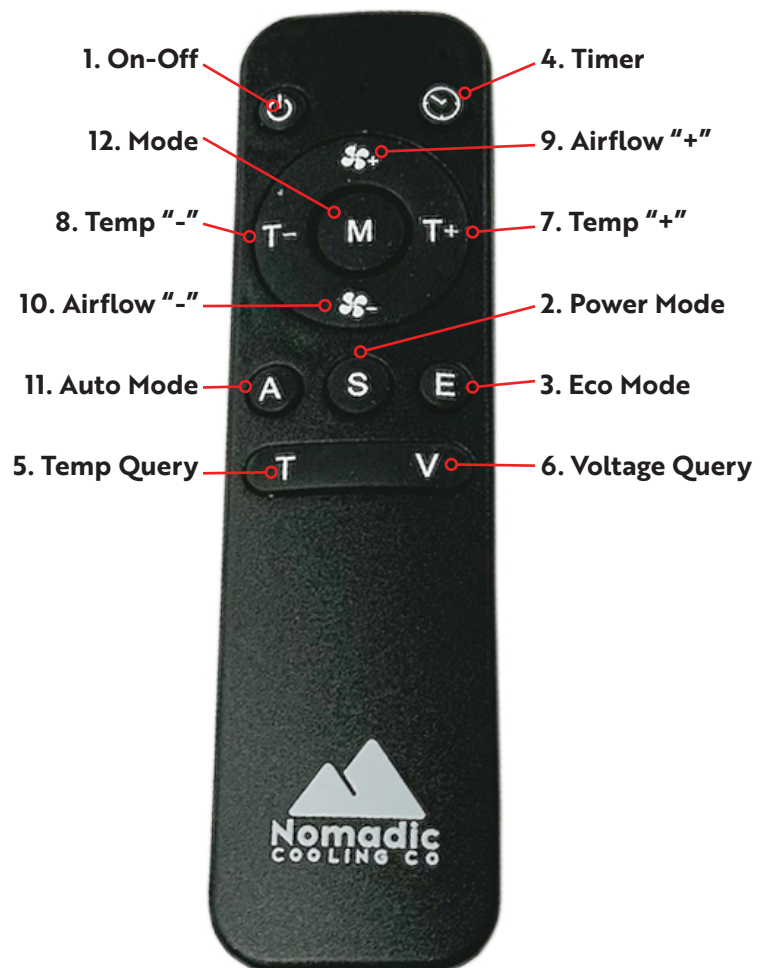

X SERIES FAULT CODES AND PROCESSING METHODS

If any of the below codes appear, turn off power to the AC unit. After 5 minutes, turn the AC unit power back on. If the fault is not solved, please refer to the maintenance manual or contact the local dealer.

Code	Description	Troubleshooting
E0	Outlet temp sensor fault	Check sensor connector
E1	Inlet temp sensor fault	Check sensor connector
E2	Low Voltage	Check battery or harness
E3	High Voltage	Check battery or power
E4	Pressure (system leakage)	Check R134a leakage
F0	Disconnected/Blocked compressor	Check cooling fan working / R134a over charge
F1	Compressor driver overheat	Check cooling fan working / Ambient >55°C
F2	Compressor driver wire low-voltage	Check harness false connection or not
F3	Compressor driver over voltage	Check wire false connection
F4	Compressor driver phase absence	Check wire false connection
F5	Driver output overload	Check wire false connection
F6	Driver output over current	Check cooling fan working / Ambient >55°C
F7	Cooling fan fault	Check cooling fan working

1. The battery power is insufficient and under voltage **E2**.
 - A. Check the battery for aging and replace it.
 - B. If the battery is not fully charged, it needs to be charged.
 - C. Connect the negative pole of the power line to the metal or the generator, reconnect the wirings or harness.
2. Pressure Fault (System leakage) **E4**.
 - Refrigerant leakage or poor heat dissipation.
3. Sensor Fault **E0 or E1**.
 - A. Check whether the plug-in is loose and re-insert it tightly.
 - B. Sensor quality problem, replace the sensor.
4. High current protection **F6**, or electronic fan fault **F7**.
 - A. Check the condenser heat dissipation, whether the surface is dirty/blocked.
 - B. Check whether the terminal or plug-in of the power line is loose.
 - C. Check if the plug-in of the fan is loose, and plug it in again.
 - D. Condenser fan failure, replace the fan.

X SERIES MAINTENANCE AND DISCLAIMERS

Maintenance

In order to ensure the normal operation of the air conditioner, please pay attention to the routine maintenance:

- (1) When idle for a long time, please remove the positive and negative power lines at the battery end. Inspect the sealing and avoid negative connection direct to ground, so as to avoid battery damage caused by long-term electrification. The power line must be connected to the battery, and it is strictly forbidden to connect negative direct to ground or connect to the generator.
- (2) Maintenance routine every three months includes cleaning evaporator and condenser, and checking internal and external circuits. The maintenance cycle should be shortened in special working conditions, such as dusty and extreme temperature environments.
- (3) It is recommended to power the AC unit with a battery bank. The use of generators, solar panels or other external charging equipment should be used only for auxiliary power.

Disclaimers

- (1) Nomadic Cooling provides installation videos and installation instructions, but users must install in accordance with the videos and instructions. If a user fails to install in accordance with the installation video and instructions provided, errors or damage and other accidents may occur, and the user shall bear the responsibility. The maintenance and material costs caused by the user shall be paid separately, and Nomadic Cooling will not bear any responsibility.
- (2) The user must pay attention to safety issues during the installation process. If personal safety issues occur, the user must bear the responsibility.
- (3) If the user changes the air conditioning unit in any way, or replaces parts and components that are not the original, the user shall bear the responsibility of any damage to the air equipment and personal safety. Nomadic Cooling will not bear any responsibility.



NC-X³ DIMENSIONS

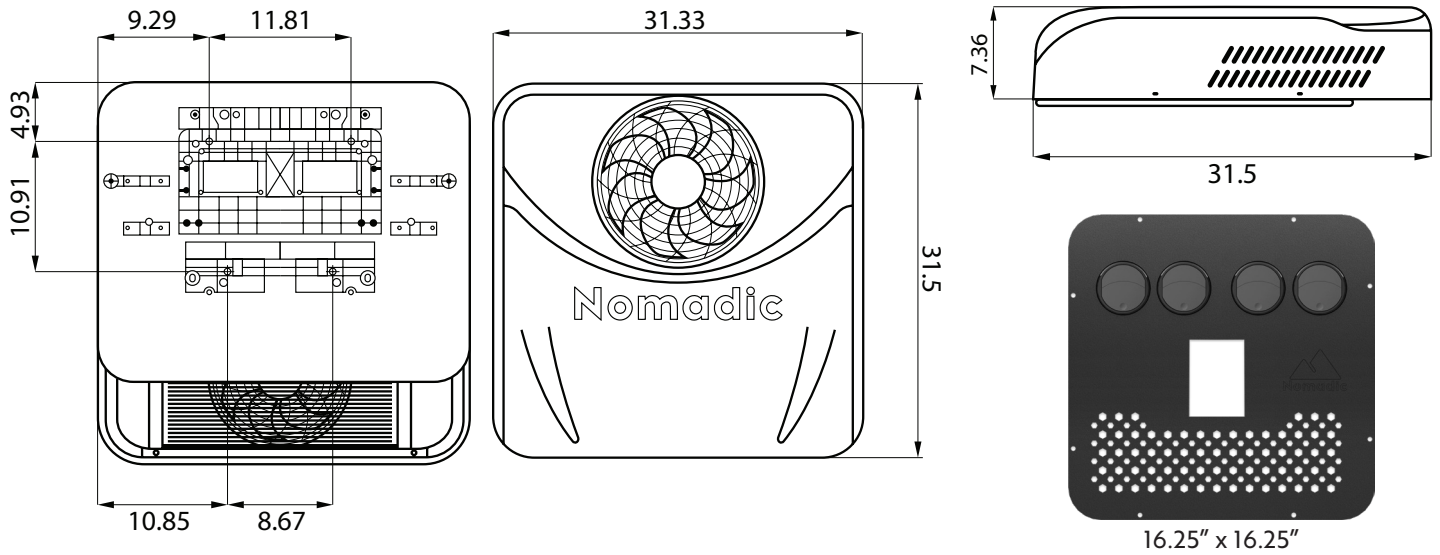

NC-X² DIMENSIONS

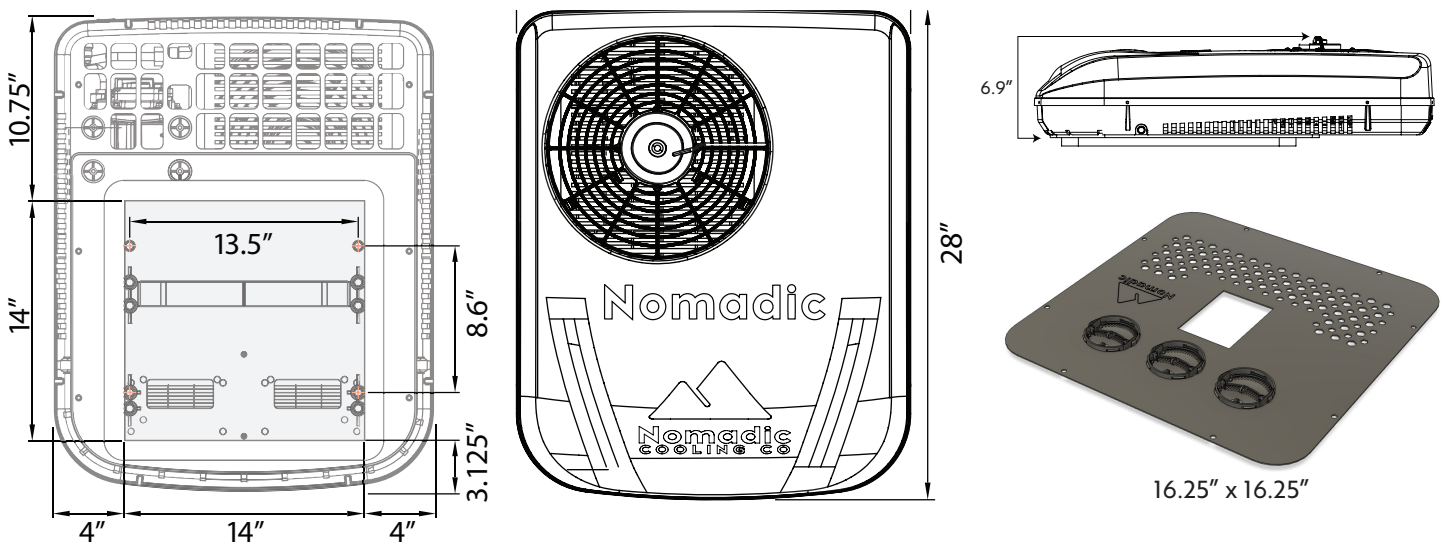

NOMADIC COOLING CO CONTACT INFORMATION

NOMADIC COOLING CO

Hours:	Monday	9am-5pm
	Tuesday	9am-5pm
	Wednesday	9am-5pm
	Thursday	9am-5pm
	Friday	9am-5pm
	Saturday	Closed
	Sunday	Closed

Address:	16680 N 51st Ave Units 4 & 5 Glendale, AZ 85306
Phone:	(480) 576-2489
Email:	info@nomadiccooling.com
Website:	NomadicCooling.com
YouTube:	NomadicCooling
Instagram:	@NomadicCooling



WARRANTY POLICY For X Series DC-Powered Rooftop AC Units

Nomadic Cooling is dedicated to delivering top-quality products coupled with outstanding customer service. We provide an industry-leading warranty for our products to ensure your satisfaction and peace of mind. Technical support is available for the lifetime of any X Series AC unit. Please review the following warranty policy.

1. Warranty Period

- X³ units are covered by a two-year warranty.
- X² units are covered by a one-year warranty.

An X Series AC unit warranty period begins on date of purchase. An optional one-year extended warranty is available for all X Series AC units. Extended warranty must be purchased prior to warranty expiration.

2. Warranty Coverage

During the warranty period, the Nomadic Cooling Co Warranty will cover all X Series AC units that experience any defects due to manufacturing or workmanship issues. The customer shall be responsible for all shipping costs to get the X Series AC unit to and from Nomadic Cooling for inspection, repair, replacement or upgrade.

3. Optional Extended Warranty (X2 and X3)

You may purchase a one-year extended warranty for any X Series AC unit which provides the same coverage as described above (#2).

4. Optional Refundable Core Charge

If you wish to have a replacement X Series AC unit shipped prior to Nomadic Cooling receiving the warranted unit, a core charge of up to 50% of the Manufacturer's Suggested Retail Price (MSRP) may apply. This core charge is intended to ensure the return of the warranted unit to Nomadic Cooling. The core charge will be added to the purchase price of the replacement unit and is refunded upon Nomadic Cooling's receipt and evaluation of the returned unit. If the warranty department determines that a defect was due to Nomadic Cooling's fault, the core charge will be refunded in full.

5. Exclusions and Limitations

The following are not covered by the warranty:

- Damage caused by misuse, negligence, accidents, or unauthorized modifications.
- Damage resulting from improper installation, maintenance, or storage.
- Damage caused by natural disasters, fire, water, or any other external factors beyond our control.
- Normal wear and tear, cosmetic damages, or minor imperfections that do not affect the functionality of the product.
- Warranty, including an optional extended warranty, is non-transferable.

6. Labor Exclusion

Nomadic Cooling's warranty policy does not cover any labor costs associated with the inspection, repair, or replacement of an X Series AC unit. Any additional expenses related to labor, including but not limited to installation, removal, or troubleshooting, shall be the sole responsibility of the customer.

7. Warranty Claims

To initiate a warranty claim, please e-mail or call us. Our representatives will guide you through the necessary steps and provide instructions on how to proceed with the warranty claim.

Please note that this warranty policy is subject to the terms and conditions stated herein and may be subject to change without prior notice. Nomadic Cooling reserves the right to determine the validity of all warranty claims and to make the final decision regarding repairs, replacements, or refunds.

**For warranty claims, additional information
or any questions, please contact us at:**

**Support@NomadicCooling.com
or call us at (480) 576-2489.**

RETURNS, CANCELLATIONS AND MISSING ITEMS

Returns

Nomadic Cooling will gladly accept returns within 30 days of acceptance of order. Please e-mail Info@NomadicCooling.com or call (480) 576-2489. Any returns after 30 days are subject to prior approval.

Only items in their original condition with all packaging, accessories, instruction manuals, warranty cards, and UPC codes will be accepted for return.

A 15% restocking fee will be assessed for all return orders. Customers are responsible for the cost of shipping of any product returned to Nomadic Cooling. We are happy to arrange for return shipping using our provider rates, or shipping can be arranged independently. Returns must include a tracking number.

If a returned product arrives at Nomadic Cooling with damage due to mishandling, poor packaging, or in otherwise unusable condition for resale, then an additional fee may be assessed.

Products should be returned to:

Nomadic Cooling Co
16680 N 51st Ave Unit 4-5
Glendale, AZ 85306

Due to some products being shipped directly from the manufacturer, please check with a Nomadic Cooling employee where to send all other returns.

Returned products will be assessed for damage upon receiving at Nomadic Cooling.

Refunds will not be processed until the product is received, inspected, and/or tested by Nomadic Cooling.

All refunds will be processed back to the original payment method and/or store credit.

Order Cancellations

If you wish to cancel your order for any reason, please let us know as soon as possible. Please e-mail Info@NomadicCooling.com or call (480) 576-2489.

If you are canceling before the order has been shipped, then we will process a refund back to the original payment method. If you are canceling after the order has been fulfilled, then the cancellation will be processed as a return and is subject the restocking fee and shipping costs. If applicable, you will be responsible for any "stop and return" fees.

Missing Items

Upon receiving your order from Nomadic Cooling, please immediately open the package and inspect the contents to ensure all items from the order have been included. If you suspect that an item is missing or the incorrect item was sent, please notify a Nomadic Cooling employee ASAP so we can assess the order. If you fail to notify Nomadic Cooling within 14 days of accepting an order with missing or incorrect items, then you will be responsible for shipping costs for the missing or incorrect item(s).

To better prevent orders with missing or duplicate items, and for ease of tracking, Nomadic Cooling will only be shipping orders once all items in the order are ready for shipping. Nomadic Cooling will not send partial shipments. Exceptions may occur when specifically requested by the customer and/or item(s) in the order are on backorder. Products are shipped the same day they are packaged and ready, unless requested otherwise.