



Installation & Operation Guide

For 13' and 10' **PROTOTYPE** Models

Nomadic Electric Awning

Item No. NA-A¹-13 and NA-A¹-10

Ver. 240205



**WE HAVE YOU
COVERED** 



**Nomadic
AWNING CO**

16680 N 51st Ave Units 4 & 5
Glendale, AZ 85306
(480) 576-2489
www.NomadicAwning.com

TABLE OF CONTENTS

Important Safety Instructions	3
Itemized Parts List	5
Technical Specifications	6
Installation Steps	7
Mounting Position	7
Support Rod Lengths	7
Bracket Mounting Positions	8
Mount the Awning	9
Receiver Wiring Schematic/Location ..	10
Remote Operations	11
Fix the Support Rods	12
Mount Rod Feet Brackets	12
Electronically Open the Awning	13
Manually Open the Awning	13
Usage of the Support Rod Bracket	14
Store the Hand Crank	14
Notice	14
Awning Maintenance	15
Proper Awning Use	16
Warranty	17
Returns, Cancellations and Missing Items ..	18



Always bench test electric awning before installing to ensure the unit powers up as it should.



**Nomadic
AWNING CO**
16680 N 51st Ave Units 4 & 5
Glendale, AZ 85306
(480) 576-2489
www.NomadicAwning.com

Keep a record of the following information:

Model No. NA-A¹-13 NA-A¹-10

Serial No. _____

Date Purchased _____

Installed By _____

INTRODUCTION

The Nomadic Electric Awning is designed and intended to be installed on flat or curved surface recreational vehicles. Installation should be performed by at least two people. At least one person should have similar installation experience. You can also elect to have it installed by an upfitter, van builder or installation specialist.

It is important to read this installation guide before starting to ensure that the awning is installed correctly and works properly.

This awning is a PROTOTYPE. Due to ongoing improvements, Nomadic Awning Co. may modify awning appearance and technical specifications without notice.



Check to ensure all required parts are included (listed on page 5).



IMPORTANT SAFETY INSTRUCTIONS

Review the following safety guidelines and instructions that can aid in reducing or eliminating the risk of accidents and injuries.

A. Safety Information Icons



The safety alert symbol is used to warn about possible risks of physical harm. To prevent injury or even death, pay attention to and follow all safety messages that appear after this symbol.

B. Understanding Signal Words

Signal words identify safety and property damage messages and indicate the degree of hazard seriousness.



WARNING is used for hazardous situations that could result injury (including death, severe, moderate or minor injury if not avoided).



NOTICE is used for situations that could result in damage to the awning or vehicle or unnecessary complications in the installation process.



HELPFUL TIP is used for useful information or best practices.

C. Supplemental Directives

Read and comprehend these instructions before installing, using, servicing, or maintaining the awning.

Poor installation, operation, servicing, or maintenance of the awning can result in severe injury.

Follow all instructions.

The installation must comply with all applicable local and national codes, including the latest edition of the following standards:

USA

- ANSI/NFPA70, National Electrical Code (NEC)
- ANSI/NFPA1192, Recreational Vehicle Code

CANADA

- CSA C22 1. Parts I & II, Canadian Electrical Code
- CSA Z240 RV Series, Recreational Vehicles

D. General Safety Messages

WARNING - Failure to follow the subsequent warnings could lead to death or serious injury.

- Use a qualified service technician if you do not have experience installing similar products.
- Do NOT modify this product in any way. Modifications can be extremely dangerous and void warranties.
- Do NOT add any devices or accessories to the awning unless specifically authorized in writing by Nomadic Awning Co.

IMPORTANT SAFETY INSTRUCTIONS



WARNINGS



Installation must be performed with the awning powered off and away from the power source during the installation process. Removal of the awning power supply wiring keeps all awning power off at all times.



Awning installation should be performed by experienced persons or specialists with the required skills. Any problems during installation may incur potential hidden dangers, such as coming detached while driving.



Wear gloves when installing the awning, or opening and closing it.



When working with a stepladder, be careful not to drop the awning when from any height.



Do not use in strong winds or snow. There is a risk of injury if the awning collapses due to strong winds or heavy snow accumulation.



If the weather goes bad (rain, snow, thunder, etc.) stop using the awning and close it immediately.



Before driving, ensure the awning is properly attached, the screws are not loose, and fabric is stored properly.



NOTICES



Handle with care. This product is shipped in the best condition.



Do not disassemble or modify. Only experienced people should make any adjustments.



Open and close the awning only when there are no other people around it. Injury can occur if the awning legs, handles, or body hit a person during opening and closing operations.



Check the awning regularly.

If you have not used the awning for a while, check and verify that the awning is properly attached, that no screws are loose, that the fabric is not scratched or torn, and that the awning can be closed and stored properly.



Do not use fire under the awning. Do not use a BBQ under the awning. It may cause a fire and is dangerous.



Do not swing the handle. Use the handle only to open and close the awning. Do not use it for any other purpose. Keep the handle out of the reach of children.



Before driving, making sure the awning is properly attached, the screws are not loose, and the fabric is stored properly.

ITEMIZED PARTS LIST

A1 Electric Awning Box Includes:

ID	Qty	Part Name	✓
A	1	Awning Case with 80cm Power Cable	<input type="checkbox"/>
B	1	Remote Control	<input type="checkbox"/>
C	1	Infrared Receiver	<input type="checkbox"/>
D	1	Hand Crank (Manual Option)	<input type="checkbox"/>
E	2	Crank Brackets & M4x25mm Screws	<input type="checkbox"/>
F	1	Remote Wall Mount Kit	<input type="checkbox"/>
G	4	Mounting Brackets for Awning	<input type="checkbox"/>
H	8	Mounting Plates for Awning	<input type="checkbox"/>
I	16	Bracket Mount M6x50mm Bolts & Nuts	<input type="checkbox"/>
J	16	Resin Gaskets for Awning Mount	<input type="checkbox"/>
K	9	Awning Mount M5x25mm Bolts & Nuts	<input type="checkbox"/>
L	2	Rod Feet Brackets & M5x25mm Screws	<input type="checkbox"/>
M	4	Ground Nails	<input type="checkbox"/>

ADDITIONAL TOOLS/SUPPLIES REQUIRED

- Silicone caulking
- 4mm, 5mm and 6mm hex keys or screwdrivers or bits
- (Optional) Electric drill with 4mm, 5mm and 6mm bits
- Wrenches
- Switch for light control (on/off)

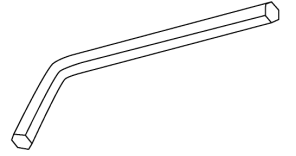

WE HAVE YOU COVERED

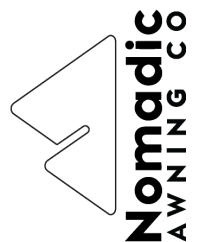

PRODUCT:
MODELS:

A¹ Electric Awning
NA-A¹-13 NA-A¹-10



Compatible with all Van and RV models

Mercedes Sprinter – Wall Mounted



A ¹ MODEL	13'	10'
Nominal Case x Awning Extension	13.1' x 8.2'	9.8' x 8.2'
Shade Surface (High noon)	107.4ft ²	80.7ft ²
Mounting Plates	Flat Surface or Rack Mount	
Mounting Plates (Coming Soon)	Curved Surface	
Rated Power	12V = 84W (or 24V = 336W)	
Rated Current	12V = 5.43A (or 24V = 14A)	
Motor (Tubular)	Worm-Gear, Ø45 Diameter, 4.2lb	
Motor Rated Torque-Speed	20Nm - 14r/min	
Motor Wire Gauge	18 AWG	
Hardware Material	Heavy-Duty Aluminum	
Hardware Finish	Electrostatic Liquid Paint	
Tension Arms	Spring-Loaded Stainless Steel Chain	
Locking Mechanism	Yes	
Pitch Adjustment	5° - 15°	
Fabric Materials	460gsm Vynilic PVC fabric	
Insulation Degree	IP44	
UV Resistant	Yes/50+ (98% UV blockage)	
Water Resistance (Grade V)	50kPa of hydrostatic pressure	
Color Fastness (to Light, Rubbing)	Grade 4-5 (highly resistant)	
Anti-Fungal Growth Rating	0 (None) @ (1.1x10 ⁶)/mL	
SVHC (Hazardous Materials)	Pass @ ≤0.1% (weight for weight)	
Light Strip	White COB LED	
Warranty	One (1) Year	

Remote Controlled

Extension Height up to 7.9"

Available in 10' and 13' case lengths providing maximum shade!



From up to 220 yards away!

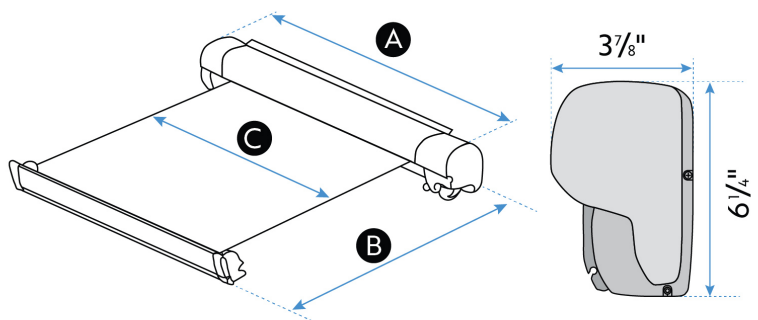
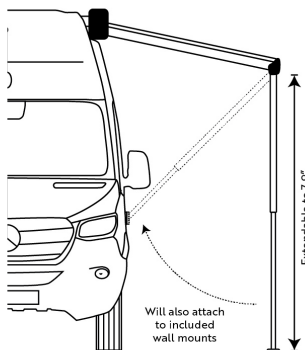

Awning Dimensions

Model	A Case Width	B Extension	C Fabric Width	Weight
NA-A ¹ -13	13.1'	8.2'	12.6'	66.8lb
NA-A ¹ -10	9.8'	8.2'	9.3'	55.8lb

INSTALLATION STEPS

Before beginning the installation, read this guide and ensure that you have all of the parts listed on page 3.

Verify that all parts are undamaged. If there are any parts that are damaged or missing, please contact your supplier.

Installation should be performed by at least two people. In addition, it is recommended that at least one person has previous installation experience, or you may consider having it installed by a specialty company.

MOUNTING POSITION

 Know in advance how to properly install the electric awning.

If the mounting surface is not vertical to the ground and all brackets cannot be mounted horizontally, use a spacer or adapter to maintain horizontal and vertical support before mounting the awning.

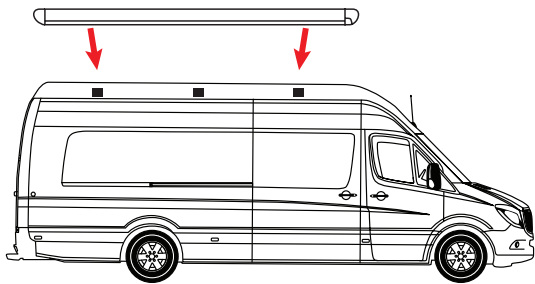

Vehicles need a vertical and flat mounting surface to directly install the awning.

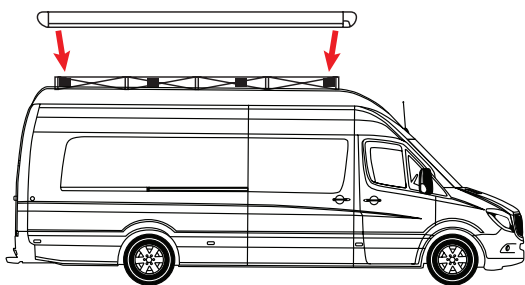

Vehicles with a non-flat bracket mounting surface require adapters or spacers to install the awning.

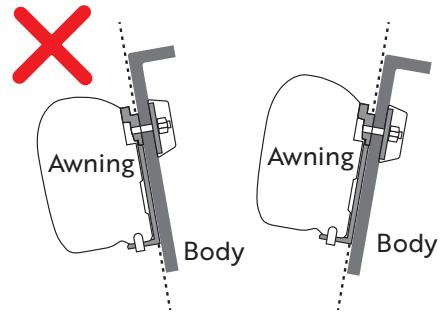

Awning body must be installed vertically.

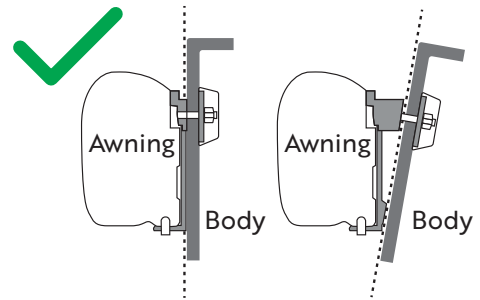

 Installing the awning at an angle can cause improper function.

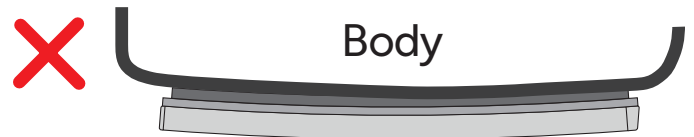

Do not install in a place where the mounting surface is curved.

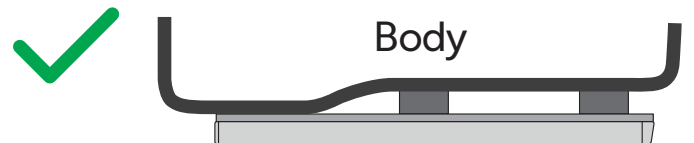

If the mounting surface is curved, use an adapter or spacer to make the mounting surface straight (not included).

SUPPORT ROD LENGTHS

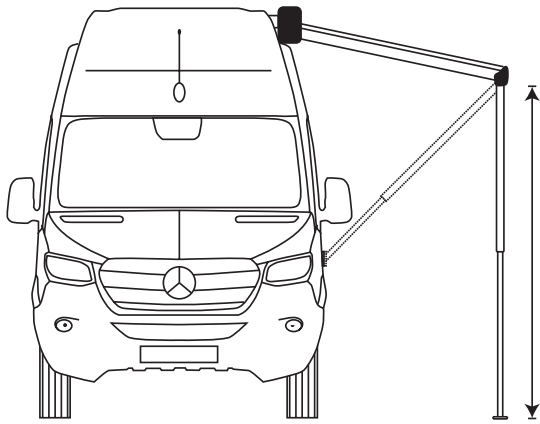

Awning Width	Max Rod Length
13.1' (4.0m)	7.9' (~2.4m)
9.8' (3.0m)	7.9' (~2.4m)

If the legs do not touch the ground when mounted at a high place, use the wall mount brackets (included) to attach standing pole legs to the vehicle's side (installation on pages 11-12).

BRACKET MOUNTING POSITIONS

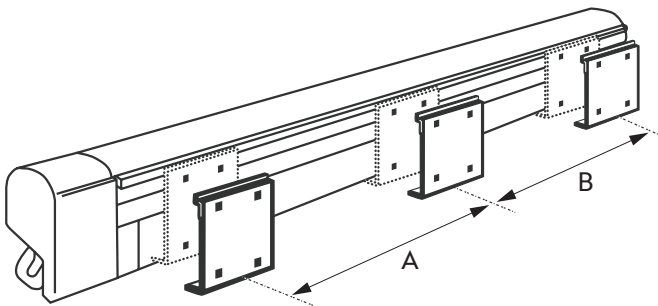

Each bracket is ~5.9" (15cm) wide. The brackets are attached to the back of awning.

Determine where to install the bracket on the vehicle. The set up position spacing has the same dimensions on the left and right ("A" and "B" are the same measurements). If using 4 brackets, the distance should be equally spaced between each bracket.

Check the measurements of "C" and decide on the awning mounting location.

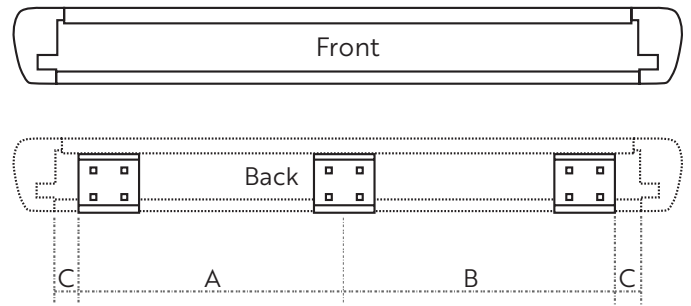

Awning Width x Extension	"C" width
13.1' x 8.2' (4m x 2.5m)	7.874" (20cm)
9.8' x 8.2' (3m x 2.5m)	0.394" (1cm)

Apply the kit to the body of the vehicle and mark the location of the holes in the bracket on the body.

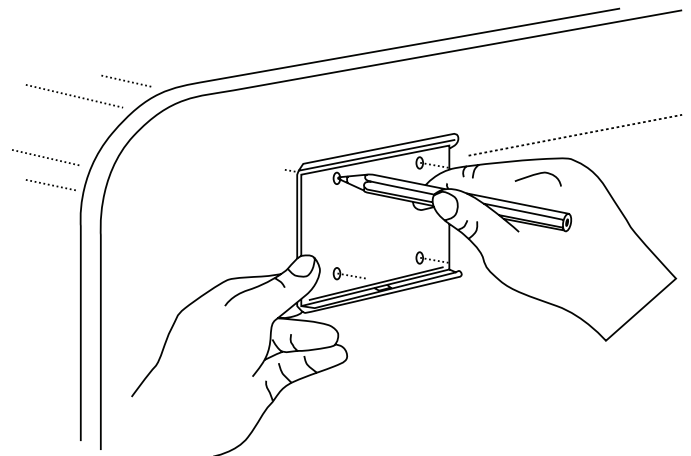

Drill holes in the marked areas.

Wall Bracket Sets

13' (4.0m) cases can use up to 4 mounting brackets.

10' (3.0m) cases will only use 3 mounting brackets.

MOUNT THE AWNING

1. Drill marked holes on vehicle's body.

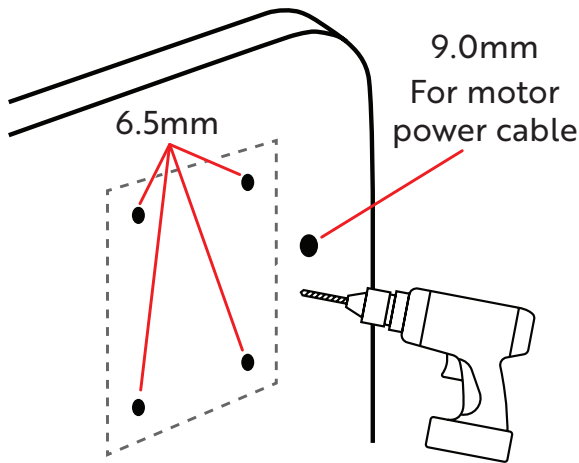

2. Install the brackets on the vehicle. Caulk the mounting surface and holes of the bracket using silicone.

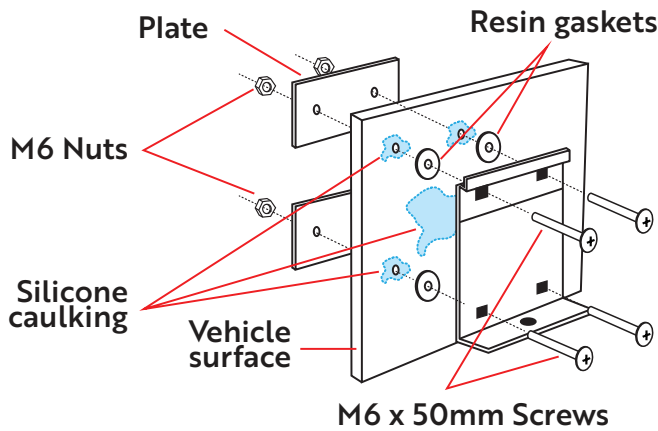

3. Attach the awning body to the brackets. (1) Seat the top of awning body to the upper part of the brackets and then (2) pivot the lower side into the brackets.

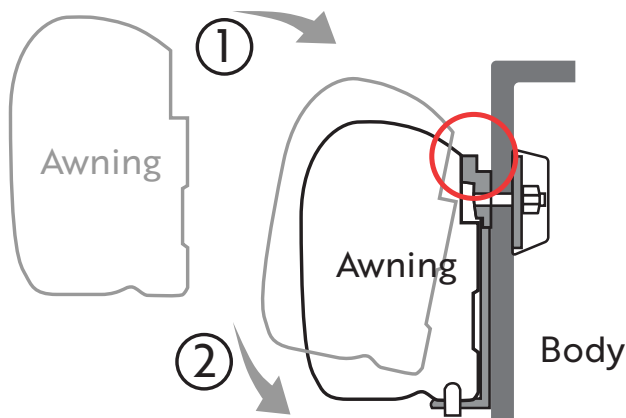

4. After installing the awning body, extend the awning about 3 ft to allow enough space to drill a hole in the bottom of the awning case using a 5.2mm drill to fit the two bottom holes of the bracket.

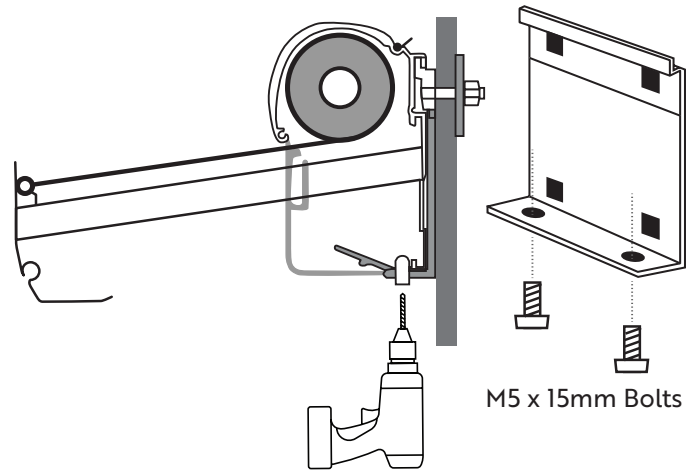

5. Attach the awning to the brackets by using the allocated M5 bolts and nuts.

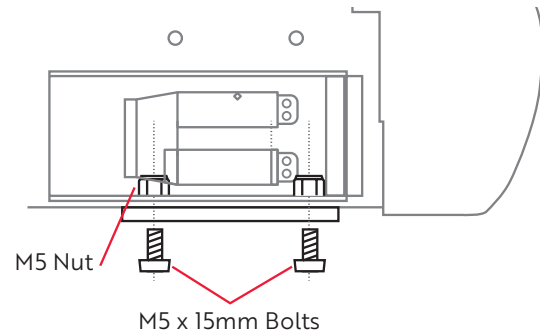

After awning is attached, check to ensure there are no problems, and then drive the vehicle for a while, and check again.

ELECTRICAL WIRING FOR THE RECEIVER

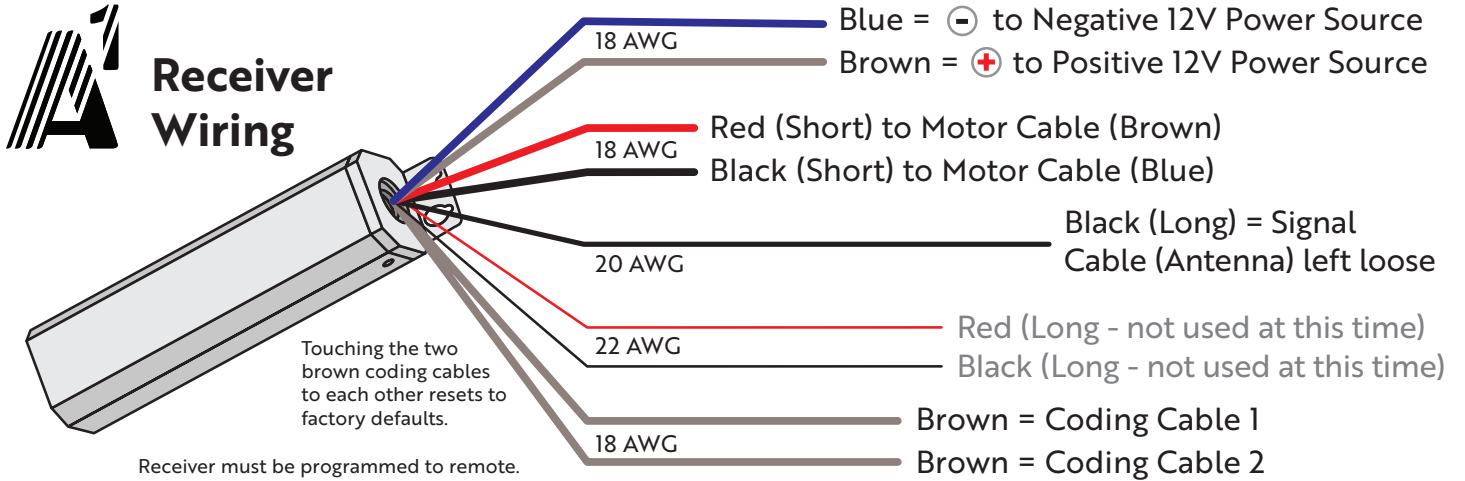

Connect the receiver only to a 12VDC power supply to avoid the potential risk of voiding your warranty.

RECEIVER INSTALLATION LOCATION

Install the receiver so that it is positioned around eye level when standing in the vehicle. The receiver should be centrally located, ensuring it is at least 8" (~0.2m) away from the awning motor (on the right side of the awning case).



Extend the wires as necessary to put the receiver inside the vehicle in the best location.

The long black cable coming out of the receiver is the signal cable (antenna). It can hang (loosely) from the receiver.

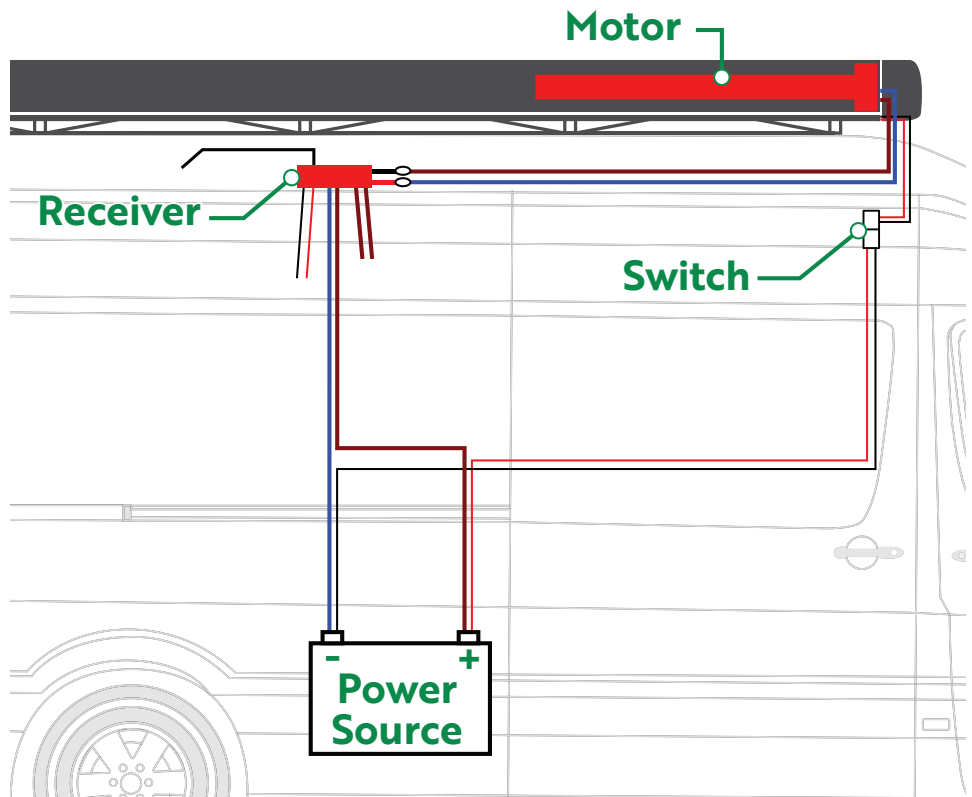

ELECTRICAL WIRING FOR THE CASE

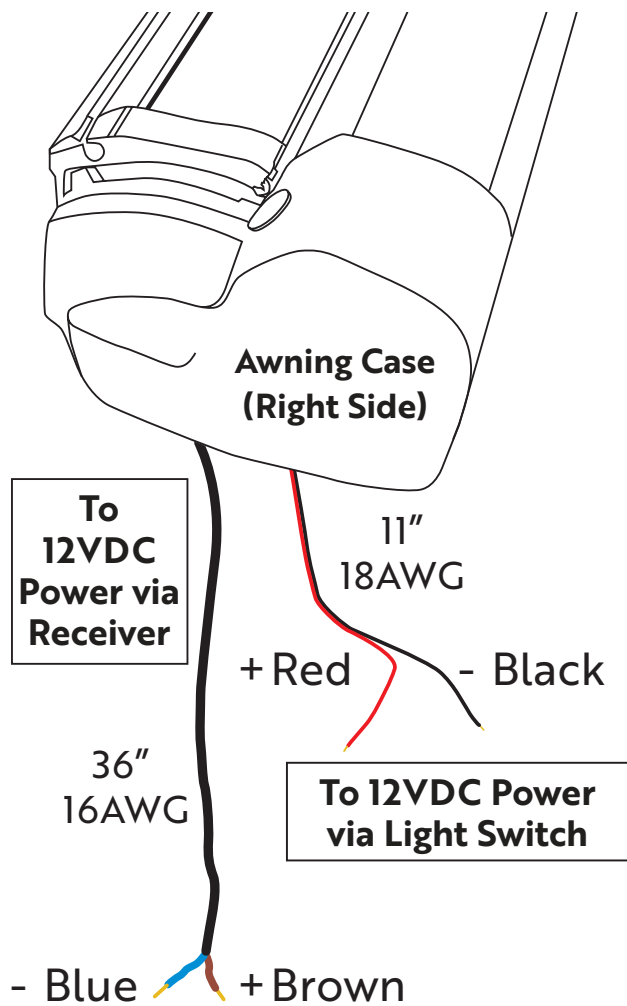

1. Connect the blue (-) and brown (+) motor power cables (~36" 16AWG) to the black (-) and red (+) cables of the receiver (above).
2. Connect the LED COB light power cables (~11" 18AWG) to a switch (not included) and then connect the switch to the 12VDC power.

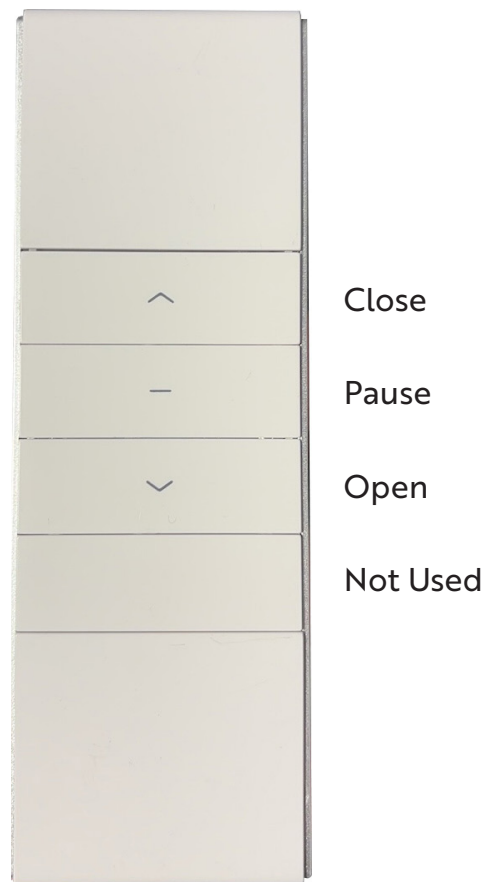

REMOTE OPERATIONS

Use only a CR 2450 battery (not included). The battery compartment is found on the back of the remote emitter.

Remote comes programmed to the receiver.

Note: As with the awning, the remote and receiver included are prototypes. We plan to replace these components with units we are currently manufacturing and will include a built in switch for the COB LED light strip and a more intuitive, easier installation process.

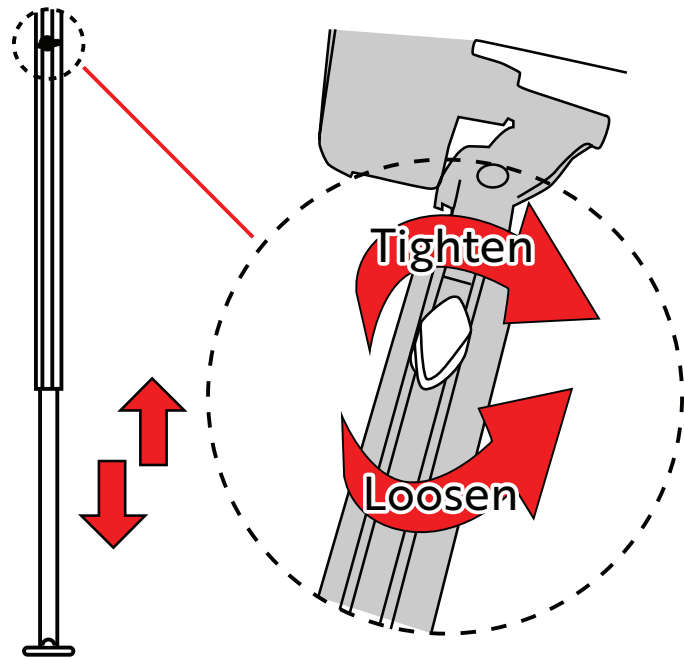

FIX THE SUPPORT RODS

1. Use hammer and provided stakes to fix the support rods to the ground.
2. By attaching two wind ropes, support rods are stronger against wind.

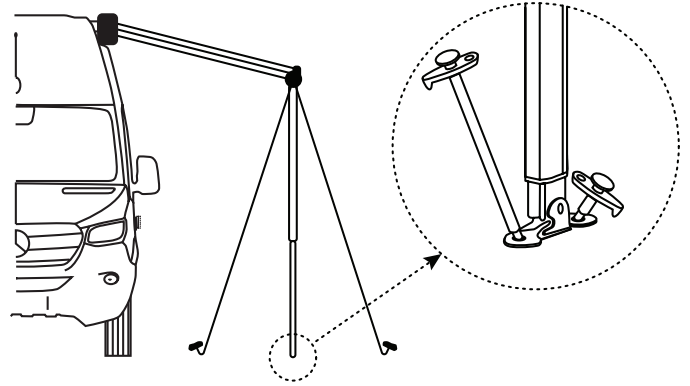

If manually opening, once the support rods are extended, turn the hand crank counterclockwise to extend the fabric out further. If the fabric becomes distorted or twisted while pulling it out, turn the handle crank slightly in the opposite direction to eliminate the distortion or twist.

MOUNT ROD FEET BRACKETS

1. Support rods can attach to the wall brackets if they are unable to reach the ground, or if the ground is uneven.
2. Decide where to attach the wall brackets. Open the awning to the desired position. The wall brackets must be installed vertically in line with the support rods.

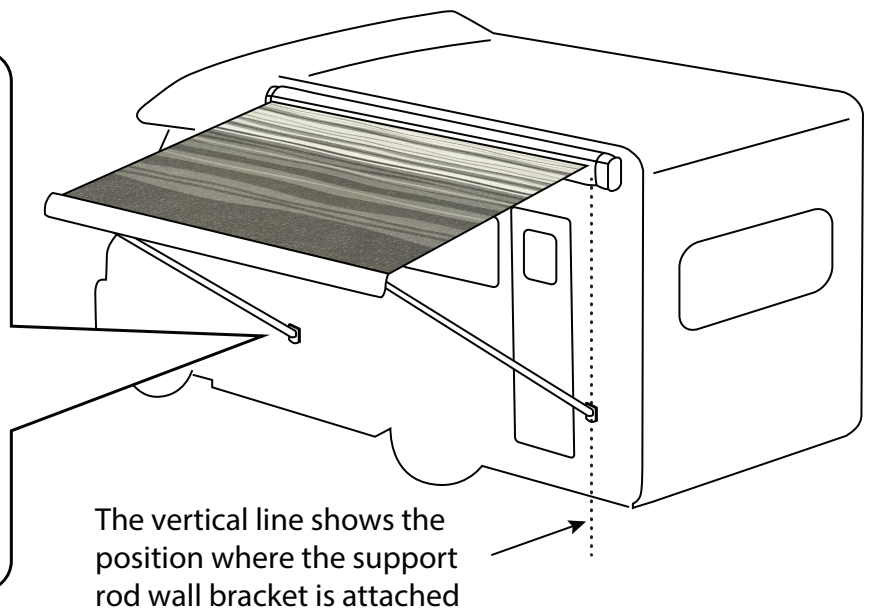
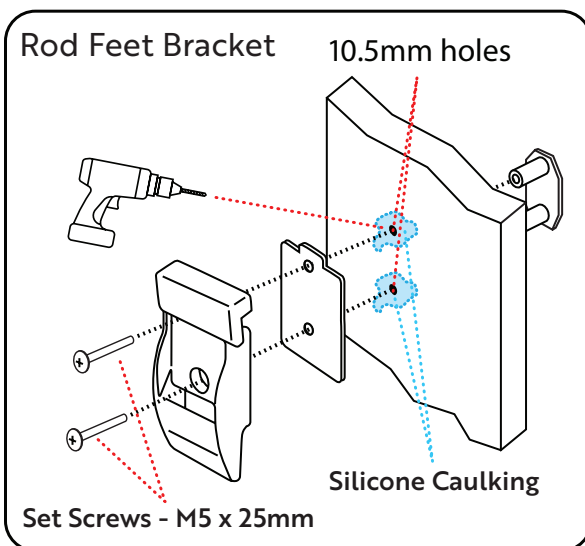

ELECTRONICALLY OPEN THE AWNING

Awning can be opened electronically using the remote control.

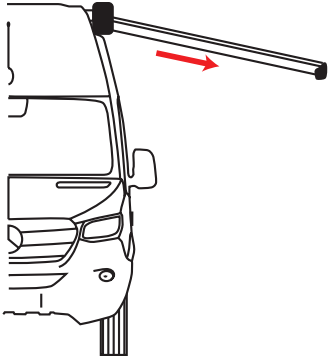

1. Press the DOWN arrow on the remote to begin unfolding the awning until it reaches the desired position.
Press the middle button “-” to pause the opening.
Press the UP arrow to begin retracting the awning into the case.



MANUALLY OPEN THE AWNING

Awning can be opened manually using the hand crank.

1. Hook the hand crank on the awning and turn counterclockwise. Pull out about 3ft.

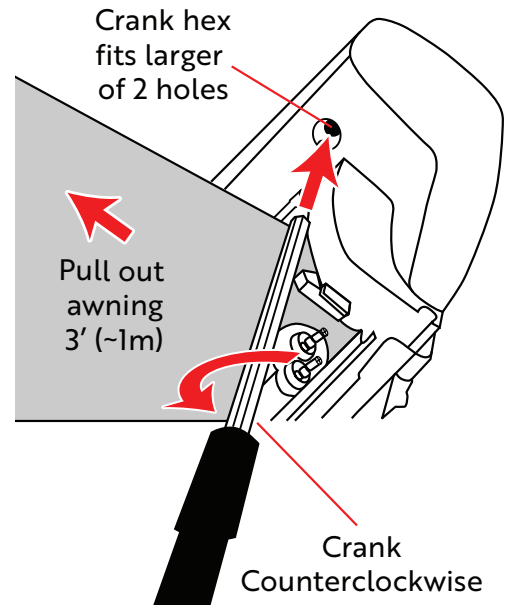

2. Pull out the left and right support rods, loosen the screw and extend the legs.

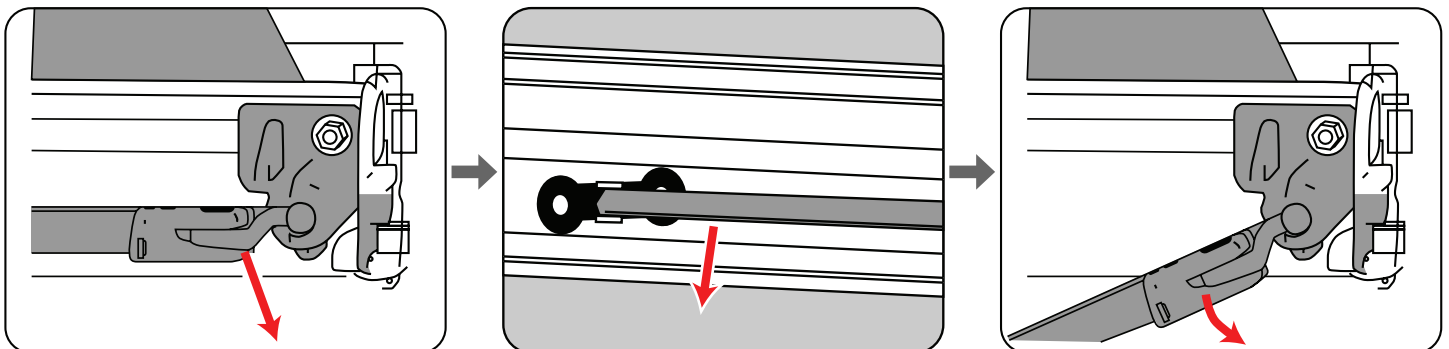
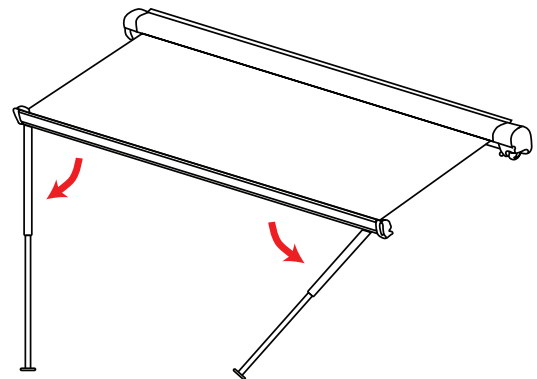

3. Apply the wall bracket to the vehicle's body and align it with the screw holes.

4. Drill two 10.5mm holes.



Be careful when drilling holes in the vehicle's body. If you make a mistake when drilling a hole position, it can be difficult to repair.

5. Caulk the threaded part with silicone to be waterproof as shown in diagram on previous page.

USAGE OF THE SUPPORT ROD BRACKET

Raise the lock clip to unlock the wall bracket and then insert the leg. Lower the lock clip to lock it place.

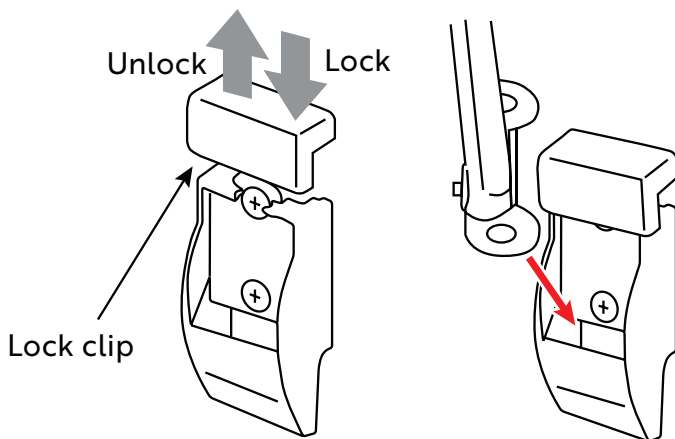

STORE THE HAND CRANK

When the hand crank is not being used, store it out of the way in the vehicle. Use the allocated hand crank wall bracket for wall mounting.

Determine where the wall bracket will be mounted. It should be somewhere safe and clear.

Attach the handle wall brackets (2) with the attached set screws M4-25mm.

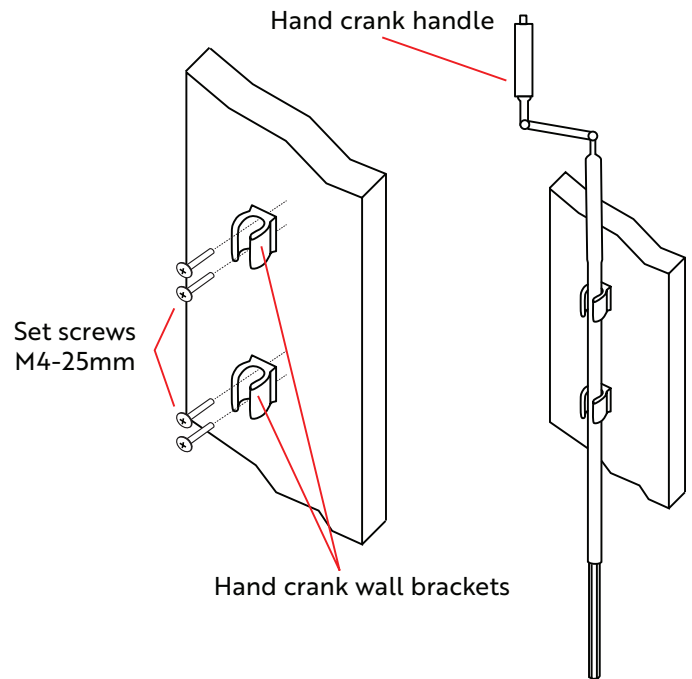

IMPORTANT NOTICES

Your Nomadic Electric Awning is intended primarily to provide sun shade. Avoid using the awning during inclement weather (heavy rain or snow). Also avoid using the awning during strong winds or if the temperature drops below 32°F.

When using the awning, you must always use the support rods, either secured to the ground using the stakes provided, or secured to the support rod brackets. Damage or malfunction caused by failure to use the support rods will void the warranty.

Please do not forget or leave the support rods in the awning's front bar.

AWNING MAINTENANCE



Please close the awning immediately if heavy rain, snow accumulation, or strong winds occur.



If the fabric gets wet, please spread out the awning and let it dry as soon as possible on a sunny day.



Regularly check the fabric for scratches, cuts, or holes. If the fabric is cut. The awning may not stow properly.



Please store the fabric in a dry state. If it is unavoidable to store the awning in a wet state, dry the fabric as soon as possible.



If the fabric ever becomes dirty, wash it off with water. If it is very dirty, use a neutral detergent to remove the dirt and dust. Rinse off the awning thoroughly with water. After drying, close the awning back up.



NEVER WASH THE AWNING WITH A HIGH PRESSURE WASHER!



Please wash the outer case together when washing the vehicle. If you clean awning with wax, it will stay clean for a longer time.



Do not use a drive-through car wash.



Before departure, please make sure that the awning is stored correctly.



If you do not use the awning for an extended period, check the awning to ensure there are no problems with the fabric or arms.

Please contact us about replacing the fabric if it ever becomes necessary.

If you have any problems during installation or operation, please contact Nomadic Awning Co. at 480-576-2489.

Thank you!

WE HAVE YOU COVERED



PROPER USE OF AWNING

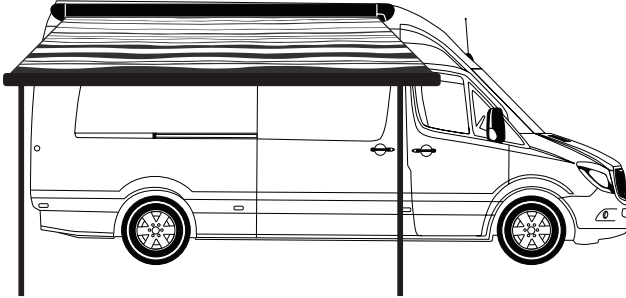

Sunny or cloudy days

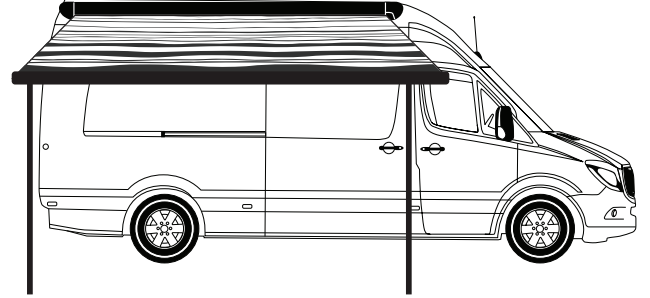

Strong Winds or Temp below 32°F



Heavy Rain, Snow, Thunderstorm

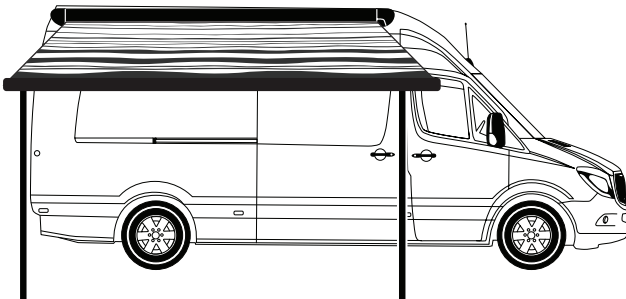

Using with standing poles

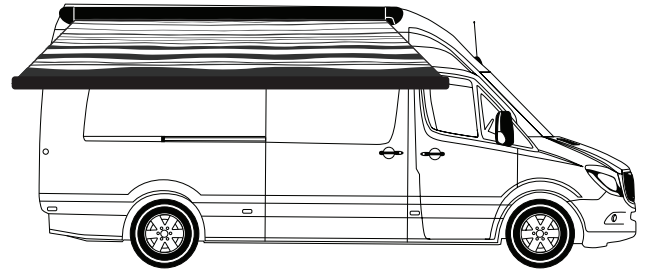

Using without standing poles

WARRANTY POLICY



WARRANTY POLICY For A¹ Electric Awnings

Nomadic Awning is dedicated to delivering top-quality products coupled with outstanding customer service. We provide an industry-leading warranty for our products to ensure your satisfaction and peace of mind. Technical support is available for the lifetime of any A¹ electric awning. Please review the following warranty policy.

1. Warranty Period

All A¹ electric awning are covered by a one year warranty period which begins on date of purchase.

2. Warranty Coverage

During the warranty period, the Nomadic Awning Co Warranty will cover all A¹ electric awning that experience any defects due to manufacturing or workmanship issues. The customer shall be responsible for all shipping costs to get the A¹ electric awning to and from Nomadic Awning Co. for inspection, repair, replacement or upgrade.

3. Optional Refundable Core Charge

If you wish to have a replacement A¹ electric awning shipped prior to Nomadic Awning receiving the warranted unit, a core charge of up to 50% of the Manufacturer's Suggested Retail Price (MSRP) may apply. This core charge is intended to ensure the return of the warranted unit to Nomadic Awning. The core charge will be added to the purchase price of the replacement unit and is refunded upon Nomadic Awning's receipt and evaluation of the returned unit. If the warranty department determines that a defect was due to Nomadic Awning's fault, the core charge will be refunded in full.

4. Exclusions and Limitations

The following are not covered by the warranty:

- Damage caused by misuse, negligence, accidents, or unauthorized modifications.

- Damage resulting from improper installation, maintenance, or storage.
- Damage caused by natural disasters, fire, water, or any other external factors beyond our control.
- Normal wear and tear, cosmetic damages, or minor imperfections that do not affect the functionality of the product.
- Warranty, including an optional extended warranty, is non-transferable.

5. Labor Exclusion

Nomadic Awning's warranty policy does not cover any labor costs associated with the inspection, repair, or replacement of an A¹ electric awning. Any additional expenses related to labor, including but not limited to installation, removal, or troubleshooting, shall be the sole responsibility of the customer.

6. Warranty Claims

To initiate a warranty claim, please e-mail or call us. Our representatives will guide you through the necessary steps and provide instructions on how to proceed with the warranty claim.

Please note that this warranty policy is subject to the terms and conditions stated herein and may be subject to change without prior notice. Nomadic Awning reserves the right to determine the validity of all warranty claims and to make the final decision regarding repairs, replacements, or refunds.

**For warranty claims, additional information
or any questions, please contact us at:**

**Support@NomadicAwning.com
or call us at (480) 576-2489.**

RETURNS, CANCELLATIONS AND MISSING ITEMS

Returns

Nomadic Awning will gladly accept returns within 30 days of acceptance of order. Please e-mail Info@NomadicAwning.com, or call (480) 576-2489. Any returns after 30 days are subject to prior approval.

Only items in their original condition with all packaging, accessories, instruction manuals, warranty cards, and UPC codes will be accepted for return.

A 15% restocking fee will be assessed for all return orders. Customers are responsible for the cost of shipping of any product returned to Nomadic Awning. We are happy to arrange for return shipping using our provider rates, or shipping can be arranged independently. Returns must include a tracking number.

If a returned product arrives at Nomadic Awning with damage due to mishandling, poor packaging, or in otherwise unusable condition for resale, then an additional fee may be assessed.

Products should be returned to:

Nomadic Awning Co
16680 N 51st Ave Unit 4-5
Glendale, AZ 85306

Due to some products being shipped directly from the manufacturer, please check with a Nomadic Awning employee where to send all other returns.

Returned products will be assessed for damage upon receiving at Nomadic Awning.

Refunds will not be processed until the product is received, inspected, and/or tested by Nomadic Awning.

All refunds will be processed back to the original payment method and/or store credit.

Order Cancellations

If you wish to cancel your order for any reason, please let us know as soon as possible. Please e-mail Info@NomadicAwning.com, or call (480) 576-2489.

If you are canceling before the order has been shipped, then we will process a refund back to the original payment method. If you are canceling after the order has been fulfilled, then the cancellation will be processed as a return and is subject the restocking fee and shipping costs. If applicable, you will be responsible for any "stop and return" fees.

Missing Items

Upon receiving your order from Nomadic Awning, please immediately open the package and inspect the contents to ensure all items from the order have been included. If you suspect that an item is missing or the incorrect item was sent, please notify a Nomadic Awning employee ASAP so we can assess the order. If you fail to notify Nomadic Awning within 14 days of accepting an order with missing or incorrect items, then you will be responsible for shipping costs for the missing or incorrect item(s).

To better prevent orders with missing or duplicate items, and for ease of tracking, Nomadic Awning will only be shipping orders once all items in the order are ready for shipping. Nomadic Awning will not send partial shipments. Exceptions may occur when specifically requested by the customer and/or item(s) in the order are on backorder. Products are shipped the same day they are packaged and ready, unless requested otherwise.