

Digital Electronic Lock

User's manual



SecuRAMTM

Breakthrough in Biometric Technology →

TD-2006-U100 Digital Electronic Lock is specially designed for use in apartments and small offices. The lock operates via passwords (4 to 10 digits) or in an emergency via an over-riding mechanical key. It has a stand-alone safety device and the special feature free-passage function for office use.

Keypad Arrangement

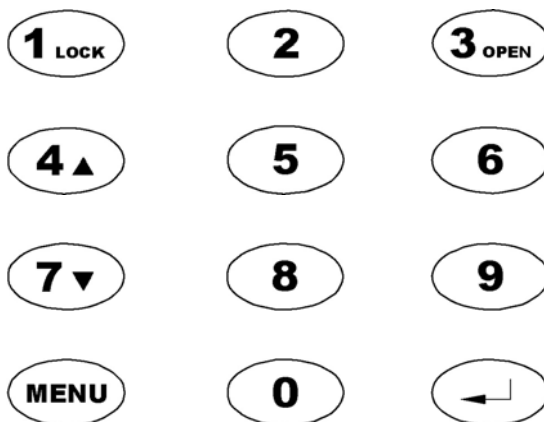

Front Panel Diagram

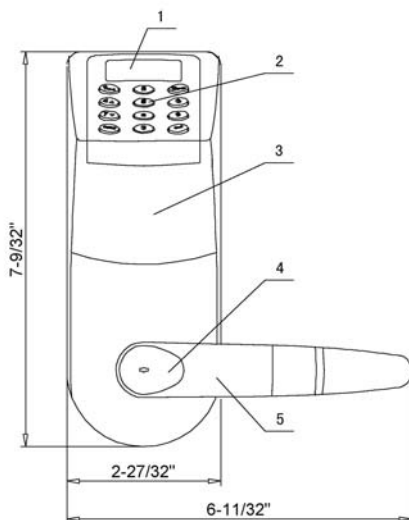

- ①: LED Display Screen
- ②: Digital Keypad
- ③: Front Panel
- ④: Cylinder Cover
- ⑤: Outside Lever Handle

Back Panel Diagram

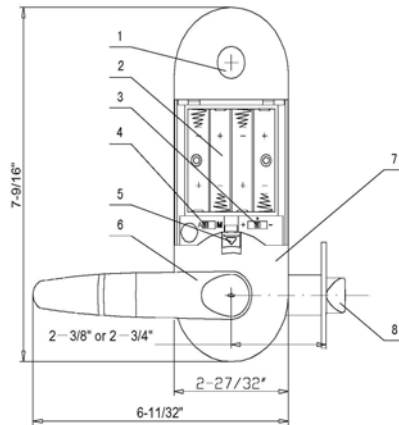

①: Decorative Cover

②: Battery Case

③: Function Switch

④: A/M Switch—Unused

⑤: Fastener of Battery Case's Cover

⑥: Inside Lever Handle

⑦: Back Panel

⑧: Latch

Contents

<i>1.How to enroll the administrator's password.....</i>	<i>7</i>
<i>2.Enroll an individual user's password via an administrator</i>	<i>11</i>
<i>3.Use an enrolled password to unlock</i>	<i>14</i>
<i>4.Change an enrolled password</i>	<i>16</i>
<i>5.Delete all enrolled passwords</i>	<i>18</i>
<i>6.Delete a specific user's enrolled password.....</i>	<i>20</i>
<i>7.Withhold a specific user's enrolled password ...</i>	<i>23</i>
<i>8.Reset a specific user's enrolled password which has been withheld.....</i>	<i>26</i>
<i>9.Use two selected enrolled passwords to co-operatively unlock</i>	<i>28</i>
<i>10.Set up Free-Passage-Mode</i>	<i>33</i>
<i>11.Withhold Free-Passage-Mode</i>	<i>34</i>
<i>12.Lock-Info display</i>	<i>35</i>
<i>13.Use the override mechanical key to unlock.....</i>	<i>37</i>
<i>14.Basic rules</i>	<i>38</i>
<i>15.Form of error info</i>	<i>39</i>

1. How to Enroll the Administrator's Password

1.1 After completing the initial installation of TD-2006-U100 Digital Electronic Lock according to its installation drawing sheet(Installation Instructions for TD-2006-U100 Lock) , move the Function Switch (located under battery cover) to the center position shown as



1.2 Install batteries.

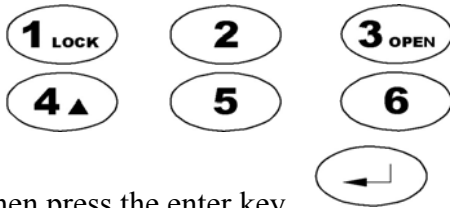

1.3 Press any key on the digital keypad to wake up the lock, meanwhile the display screen will show two red bars  .

1.4 Input the default password:1 2 3 4 5 6 (set up in the factory) by pressing the digital keys as below:







then press the enter key

1.5

Now the display screen shows , meanwhile, the LED indicator's green light blinks, with a “beep-beep” sound, and the lock is in the open status, with  on the display screen.

1.6

Press  and the display screen shows two flashing letters . Then, press  and there will appear  on the screen, so that the lock will be in the status of changing the passwords.

1.7

Input the initial password (4 to 10 digits) selected by the Administrator, so as to delete

the factory-set default password. Press



to confirm, and the display screen

shows . Input the same password again



and press . Then, the display screen

will show two red bars .

1.8 By now, this password has been enrolled as the Administrator's one. The lock will open by turning the outside lever handle downwards.



Note



◆ If the Administrator inputs the password corresponding to  being different from that corresponding to , a long beep will sound and the LED indicator's **red** light blinks. The display screen will show  again to remind the Administrator to restart inputting the initial password.

◆ The default password 123456 will be deleted automatically after the operation mentioned as the above procedures 1.6 and 1.7.

◆ After the password has been set, please try to use it to unlock so as to make sure the password has been correctly enrolled. .

◆ The initial password corresponding to the ID No. , is called as the Administrator password. Administration is controlled only by the password corresponding to ID No.  or that corresponding to ID No. , and these two passwords can easily adding or deleting an individual user's password.

2. Enroll An Individual User's Password Via An Administrator

2.1 The Function Switch is set to the center position



2.2 Press any key on the keypad to wake up the lock, meanwhile the display screen will show two red bars



2.3 Input the Administrator's enrolled password, and press



, then the display screen shows



, meanwhile, the LED indicator's green light blinks, with a "beep-beep" sound, and the lock is in the open status, with the ID No. of the Administrator on the screen.

2.4 Press



and the display screen shows two flashing letters





. Press



, the display screen will show



2.5 Input a password (4 to 10 digits) selected by an individual user. Press  and the display screen shows . Input the same password again and press .

2.6 The display screen shows the ID number corresponding to this password. By now, this individual user's password is enrolled.

Note





◆ If a user inputs the secondary password being different from the primary one, a long beep will sound and the LED indicator's red light blinks. The display screen will show  again to remind the user to restart inputting the primary password.

◆ After the password is added, try to use it to unlock so as to make sure the password has been

correctly enrolled.

◆ If a user needs to continuously enroll several passwords, the user can do like this:

when the display screen shows ID No., press  and , then the display screen will show . Then, the user needs only to follow the procedures 2.5 and 2.6.

◆ For security, a password cannot be set as 123456 which is the default password set up in the factory.

◆ An individual user can only change its own enrolled password, but cannot add an enrolled password or delete other's enrolled password.

◆ The Administrator can delete any of the individual users' enrolled passwords and set up the initial enrolled password for an individual user.

3. Use An Enrolled Password To Unlock

3.1 The Function Switch is set to the center position



3.2 Press any key to wake-up the lock.

3.3 The display screen shows . Simply input

the correct enrolled password and press



. Now the display screen shows the

corresponding ID No., meanwhile, the LED

indicator's green light blinks, with a “beep-

beep” sound, and the lock is in the open status.

Then, the lock will open by turning the outside

lever handle downwards.

Note



◆ In case of inputting an enrolled password, if one has delayed to press any key for 10 seconds, this input will be cancelled and the lock will be in the awaiting mode.

◆ When a password has been enrolled, the display screen will show the ID No. corresponding to this password.

4. Change An Enrolled Password





4.1 The Function Switch is set to the center position







4.2 Press any key on the keypad to wake up the lock, meanwhile the display screen will show two red bars .

4.3 Input the enrolled password to be changed, and press , then the display screen shows the ID No. corresponding to this password and meanwhile, the LED indicator's green light blinks, with a “beep-beep” sound, and the lock is in the open status.

4.4 Press and the display screen shows two flashing letters . (If the display screen shows two flashing letters ,

press the keys  or  until there appears  on the screen.) Then, press  and there will appear  on the screen, so that the lock will be in the status of changing the passwords .

4.5 Input a new selected password (4 to 10 digits) so as to change the former enrolled password. Press  to confirm, and then the display screen shows  . Input the same password again and press  . The display screen will show two red bars  . By now, the former enrolled password has been changed into the new enrolled one.

Note 

The password to be changed must have been already enrolled.

5. Delete All Enrolled Passwords

5.1 Move the Function Switch to the position



5.2 Press any key on the keypad to wake up the lock, meanwhile the display screen will show two red bars



5.3 Press **MENU**, and the display screen shows two flashing letters



5.4 Press , and the display screen shows the ID Nos. being deleted one by one.

After finishing the deletion, there will appear



Note 

◆ The display screen will show  if the deletion is unsuccessful. Try the above deletion again.

If the deletion is still unsuccessful, the lock shall be sent back to the Seller's factory for maintenance.

◆ The Administrator's enrolled password will be again automatically reset to the default password 123456 corresponding to the ID No.  after the above deletion.

◆ After finishing the deletion, the user must move the Function Switch to the center position



6. Delete A Specific User's Enrolled Password



6.1 The Function Switch is set to the center position



6.2 Press any key to wake-up the lock.

6.3 The display screen shows . Input the

Administrator's enrolled password



corresponding to  or 

(Administrators' ID Nos.) and press





. The display screen shows the ID No. corresponding to this password and meanwhile, the LED indicator's green light blinks, with a "beep-beep" sound, and the lock is in the open status.

6.4 Press  and the display screen shows

two flashing letters **SE**. Press the keys **7** or **4** until there appears **DE** on the screen. Then, press  and there will appear the ID No. **01** or ID No. **02**. Press the keys **7** or **4** to select the ID No. corresponding to the enrolled password to be deleted. Press the , this ID No. together with its corresponding enrolled password will be deleted, and there will appear the next ID No. to be deleted.

6.5 If the deletion will continue, just operate as above procedures. If it is necessary to stop the deletion, press  to quit.

Note 



The enrolled password corresponding to 
or the enrolled password corresponding to  can
be crosswise-deleted, but either of these passwords
can't delete itself.

7. Withhold A Specific User's Enrolled Password

7.1 The Function Switch is set to the center position





7.2 Press any key to wake-up the lock, and the display screen shows  .

7.3 Input the Administrator's enrolled password corresponding to  or  (Administrators' ID Nos.) and press  .

The display screen shows the ID No. corresponding to this password and meanwhile, the indicator's green light blinks, with a “beep-beep” sound and the lock is in the open status.

:

7.4 Press **MENU** and the display screen shows two flashing letters **SE**. Press the keys **7** or **4** until there appears **UL** on the screen. Then, press , and the display screen will show **EE**. Press the keys **7** or **4** to select the ID No. corresponding to the enrolled password to be withheld (except this ID No.). Press the , the enrolled password corresponding to this ID No. will be withheld. It is possible to further withhold another specific user's enrolled password in the same procedure.

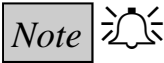





The specific user's enrolled password is withheld after it has been withheld through its ID No. The user can't open the lock by this withheld password. The user can operate with this password only after it has been reset. The enrolled password corresponding to ID No. **08** or that corresponding to ID No. **02** can't be withheld.

8. Reset A Specific User's Enrolled Password Which Has Been Withheld







8.1 The Function Switch is set to the center position



8.2 Press any key to wake-up the lock, and the display screen shows .

8.3 Input the Administrator's enrolled password corresponding to  or  (Administrators' ID Nos) and press .

. The display screen shows the ID No. corresponding to this password and meanwhile, the indicator's green light blinks with a "beep-beep" sound and the lock is in the open status.

8.4 Press  and the display screen shows two flashing letters . Press the keys  or  until there appears  on the screen. Then, press , and the display screen will show the ID No. corresponding to the enrolled password which has been withheld. Press the , the specific user's enrolled password which has been withheld and corresponding to this ID No. will be reset. By the same procedure as above, it is possible to further reset another specific user's enrolled password which has been withheld.

9. Use Two Selected Enrolled Passwords To Co-operatively Unlock



9.1 The Function Switch is set to the center position



9.2 Firstly, enroll at least two individual user's passwords according to the procedures mentioned in ***Section 2. Enroll An Individual User's Password Via An Administrator.***

9.3 Press any key to wake-up the lock.

9.4 The display screen shows . Input the





Administrator's enrolled password corresponding to  or  (Administrators' ID Nos.) and press 



. The display screen shows the ID No. corresponding to this password and meanwhile,



the indicator's green light blinks, with a "beep
-beep" sound, and the lock is in the open status.

9.5

Press **MENU** and the display screen shows two flashing letters **SE**. Press the keys **7▼** or **4▲** until there appears **□□** on the screen. Then, press **←**, and the display screen will show **□H** for one second. Press the keys **7▼** or **4▲** to select the ID No. corresponding to one individual user's enrolled password (except the ID No. **01** or ID No. **02**). Press the **←**, this user's enrolled password corresponding to this ID No. is confirmed as the enrolled password corresponding to **□H**. The display **□2** screen will show for one sec. Press the keys **7▼** or **4▲** to select



the ID No. corresponding to the other individual user's enrolled password (except the ID No.  or ID No. ). Press , that user's enrolled password corresponding to that ID No. is confirmed as the enrolled password corresponding to .



Then, there will appear  on the screen, which means it has been completed to set up the operation mode of using two selected enrolled passwords (one corresponding to  and the other corresponding to ) to cooperatively unlock.

From then on, it is possible to easily use two selected enrolled passwords (one corresponding to  and the other corresponding to ) to cooperatively unlock according to the following

procedures:

1) Press any key to wake-up the lock, and the display screen shows  .

2) Input the enrolled password corresponding to  (One Cooperative User's ID No.) and press  . The display screen shows  .





3) Input the enrolled password corresponding to  (the Other Cooperative User's ID No.) and press  . The display screen shows the ID No. corresponding to  .

Meanwhile, the indicator's green light blinks with a "beep-beep" sound and the lock is in the open status.

Then, the lock will open by turning the outside lever handle downwards.



Note



In the operation mode of using two selected Enrolled passwords to cooperatively unlock, the lock can be unlocked only via the enrolled password corresponding to  and that corresponding to . When the ID No. corresponding to  is deleted, the ID No. corresponding to  will also be deleted.

10. Set Up Free-Passage-Mode





10.1 Unlock the lock by an enrolled password.

10.2 Press  and hold until the screen shows the ID No. corresponding to this password. There will occur a “beep-beep” sound. Then, loosen the user’s finger, and the display screen will show . Now, the lock is set to a free passage mode (the lock is in the open status all the time).

10.3 In this case, the lock will open at any time by just turning the outside lever handle downwards.

II. Withhold Free-Passage-Mode

11.1

In the awaiting status, with two red bars  shown on the display screen, press  and hold until there occurs 1 “beep-beep” sound. Then, loosen the user’s finger. The display screen will show  . and then two red bars  , which means that it has withheld the Free-Passage-Mode.

12. Lock-Info Display

12.1

The Function Switch is set to the center position



12.2

Press any key to wake-up the lock.

12.3

The display screen shows . Input the

Administrator's enrolled password

corresponding to  or 

(Administrators' ID Nos.) and press



. The display screen shows the ID No. corresponding to this password and meanwhile, the LED indicator's green light blinks, with a "beep-beep" sound, and the lock is in the open status.

12.4

MENU

Press

and the display screen shows

two flashing letters **SE**.

Press the keys

7▼

or

4▲

until there appears

in

on the screen. Then, press

←

and

there will appear such lock info as

99

(which

means the maximum number of enrolled passwords) and

so on.

13. Use The Override Mechanical Key To Unlock In An Emergency

In an emergency or in case that the electronic part of the lock fails to work normally, an override mechanical key can be used to unlock the door.

13.1 Insert the Cylinder-Cover removal tool so as to remove the oval cover.

13.2 Insert the override mechanical key and turn clockwise 90°.

13.3 Turn the lever downward to open door and take the key.

14. Basic Rules

14.1 To press  means to choose menu or to cancel.





14.2 The enter key  is used for confirming.

14.3 A “beep- beep” sound is used for confirming a program has been finished, e.g. the input of a password or the enrollment of a password has been finished).

14.4 A long beep means there occurs an error.

14.5 In case of unlocking, the display screen will show  and there will be a beep warning sound if batteries are low.

15. Form of Error Info

Error Code	Error Type
	Error of EEPROM in CPU: if it happened repeatedly, the lock needs maintenance
	Error of deleting the enrolled password: if it has happened repeatedly, the lock needs maintenance
	No more passwords can be enrolled.
	Low voltage: batteries need to be replaced

SPECIFICATIONS:

- Password Capacity : (TD-2006-U100) 99 passwords
- FRR : <0.1%
- FAR : <0.0001%
- Password length : 4 to 10 digits
- Static Current: 15 μ A (standard)
- Power Supply: 4 AA-size alkaline batteries or 4 AA-size rechargeable batteries (1.2V, 1800mA.h)
- Battery Life Span: At least 2 to 3 years (assuming the lock operates 10 times per day.)
- Emergency Override Key: 8-pin key cylinder
- Dimensions: 192mm \times 72mm
- Operating Temperature: - 40 $^{\circ}$ C to + 70 $^{\circ}$ C
- Operating Humidity: 10% to 80%

Note:

Due to difference in battery capacity, the digital electronic lock is tested based on the battery capacity of 500mA.h.

SecuRam Inc. U.S.A.