

SPORTS AFIELD®

Established 1887



INSTINCT

INSTINCT BIOMETRIC SERIES INSTRUCTION MANUAL FOR SA5520INS-BIO



BIOMETRIC [SECURE ENTRY]

IMPORTANT:

Please read this information and follow all safety rules carefully before operating your gun safe. Failure to do so will void your warranty.

WARNING



Tip Over Hazard

A child or adult can tip the safe and be killed or seriously injured.

Failure to secure the safe as shown in these instructions can result in death or serious injury to children and adults.

Children should not play with or around the safe at any time.

DISCLAIMER - READ BEFORE SAFE SETUP

PLEASE READ THIS INFORMATION CAREFULLY BEFORE OPERATING YOUR SPORTS AFIELD SAFE.

DO NOT LOCK THIS MANUAL OR THE BACKUP KEYS IN YOUR SAFE.

- Thank you for choosing a Sports Afield Safe to protect your valuables. We are committed to securing, organizing and protecting your most important documents, valuables and keepsakes.
- Your safe is built to last a lifetime. However, please understand that the locking mechanism has precision parts. If you experience ANY difficulty opening or closing your safe, **DO NOT FORCE THE SAFE OPEN**. Doing so may jam the components in the lock, which will require a safe technician to unlock your safe. This causes an inconvenience to you and may lead to a claim denial.
- If you experience problems or challenges with your safe, please contact us. Many issues can be quickly resolved without the product being returned.

Safes & More Customer Service - 888-717-4819

SAFETY

- Safe bodies and doors are extremely heavy thus SA Consumer Products requires a minimum of two people to insure stability of the safe during installation. Always ensure proper installation, as laid out in this manual, and do not open the door with the safe on an uneven or unstable floor. Ignoring this could result in serious injury or death.

WEAPON STORAGE

- If you choose to utilize this safe to store a weapon always follow proper weapon and local laws.
- SA Consumer Products strongly recommends that you do not store firearms.
- Always follow the firearm safety rules set out by the firearm's manufacturer.
- A Sports Afield Safe or any other firearm storage device cannot take the place of other safety procedures including advising children of the dangers of firearms.
- SA Consumer Products and its distributors of the Sports Afield Safes do not recommend, suggest, advise, promote, or otherwise condone the ownership or use of firearms. We believe the decision to own or use a firearm is a serious decision that should only be made by an adult who has carefully considered the risks and benefits of such a decision.

2. UNDERSTANDING YOUR SAFE

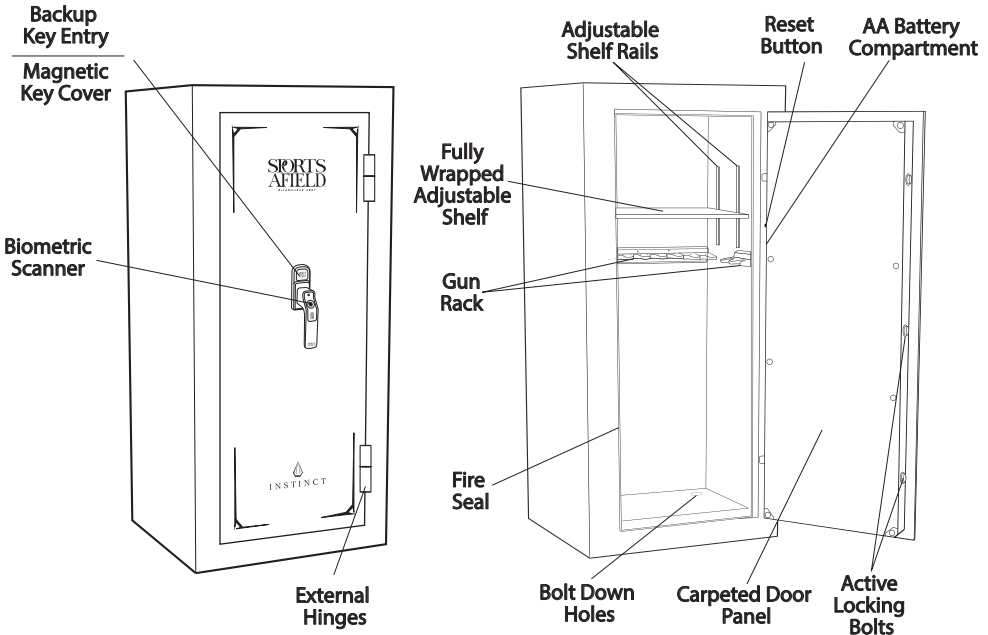

3. UNBOXING

WARNING: SAFES ARE HEAVY AND CAN BE UNSTABLE ON UNEVEN GROUND. PLEASE ENSURE EXTRA CAUTION WHEN DEALING WITH OR MOVING UNSECURED SAFES. WHILE UNBOXING BE SURE TO HAVE A SECOND PERSON HOLD AND STABILIZE THE SAFE TO KEEP IT FROM TIPPING, CAUSING INJURY, AND/OR DAMAGE TO THE SAFE AND SURROUNDING STRUCTURES.

- Remove the packaging. If your safe is still on shipping feet you can simply lift the box up and off the safe once the strapping has been removed. If your safe does not have shipping feet you will need to carefully remove the box, ensuring not to damage the safe and/or injure yourself. You will want to have someone stabilize the safe when removing the cardboard and other packing material from underneath the safe.

4. INSPECTION

- Make sure to inspect your safe for shipping damage before accepting delivery. If you find any damage, please contact the delivery company (or carrier) immediately.
- Any damage not noted upon delivery must be reported within fifteen (15) days or there will be no recourse. Any noted damage at the time of delivery must be resolved with the delivery company and/or retailer. Shipping damage is not warrantable by SA Consumer Products.

5. INITIAL ENTRY

1. Locate the user manual and backup keys inside the plastic bag hanging on the front of the safe.

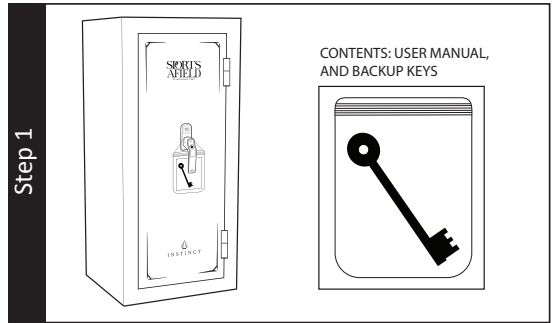

2. Remove key cover.

Insert and turn the key clockwise from 12 o'clock to 3 o'clock to unlock. Rotate drop handle counter-clockwise to open safe.

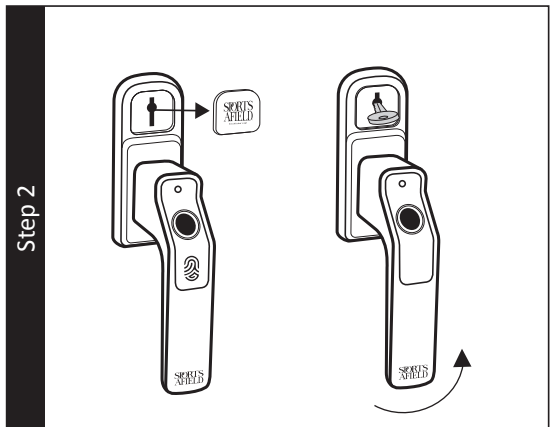

3. Locate the (4) AA batteries and insert in the battery compartment on the inside of the door panel. Unit will beep when batteries are successfully installed. Replace battery cover.

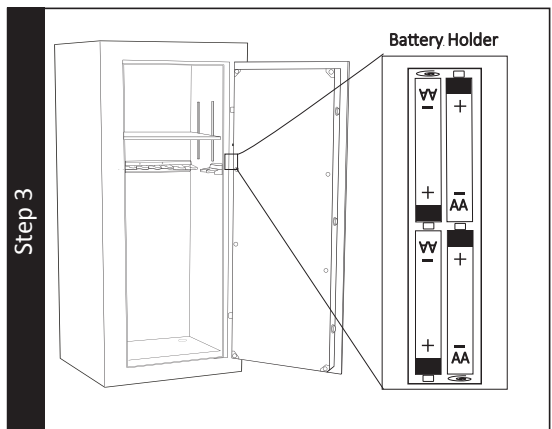

WARNING: The batteries must be inserted with the correct polarity. Exhausted batteries must be removed from the product and discarded safely. Do not mix old and new batteries. Do not mix alkaline or standard (carbon – zinc) batteries. Do not use rechargeable (nickel – cadmium) batteries.

6. PROGRAMMING YOUR FINGERPRINT

1. On the inside of the safe, near the battery compartment, locate the brass cap. Unscrew and remove the cap. Press and release the reset button. The indicator ring will illuminate indicating the safe is now in programming mode.
Keep safe door open while programming new fingerprint

NOTE:

Programming mode will time out after 10 seconds of inactivity. If this occurs press reset button and begin again.

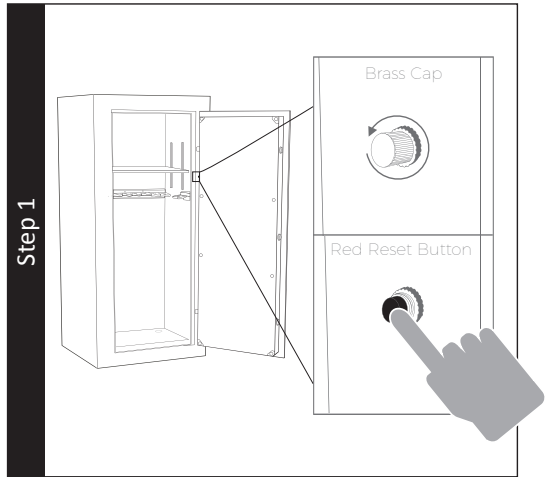

2. **PLACE AND HOLD** the pad of your thumb on the scanner until indicator ring and LED light flash green once and beeps once.

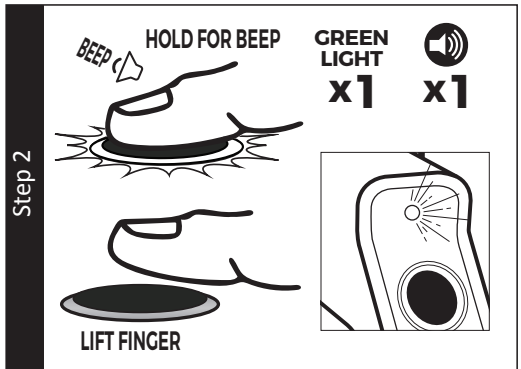

3. **REPEAT** at least 3 more times until there are 2 consecutive beeps and 2 green flashes.

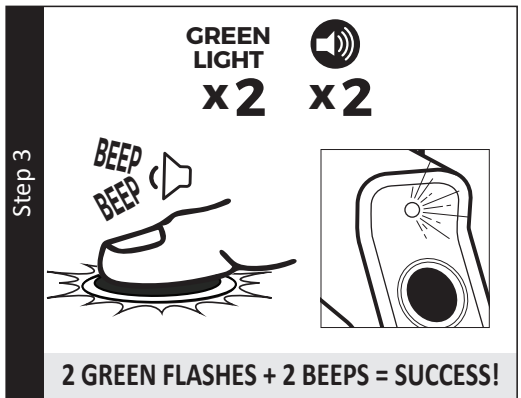

7. ACCESS TEST

1. With keys in hand, place your programmed fingerprint on the scanner. 2 green light flashes and 2 beeps will confirm the fingerprint has been accepted.

Next, rotate the handle counter-clockwise. The locking bolts will retract and the door will open.

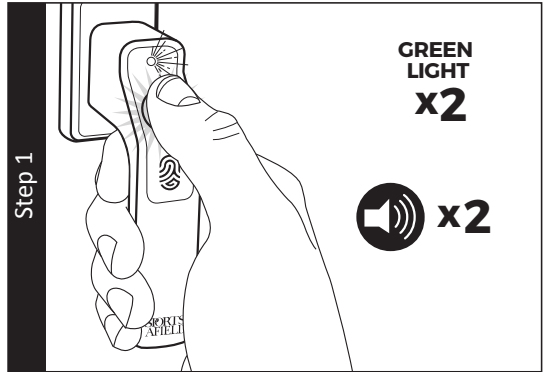

If your print is not accepted: you will see 1 red light flash with 1 beep. This means the scanner did not read your fingerprint (try again).

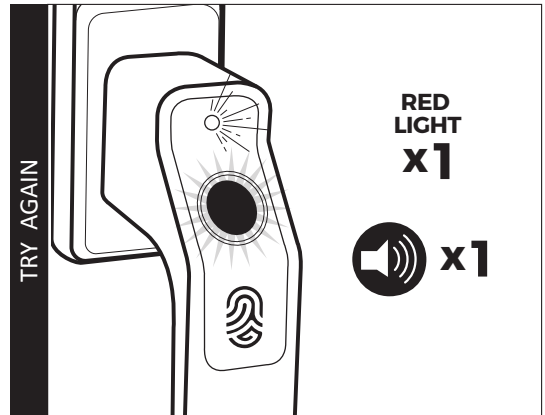

If you see 3 red flashes with 3 beeps, the scanner read your fingerprint but did not accept it. Follow section 6 to reprogram your fingerprint.

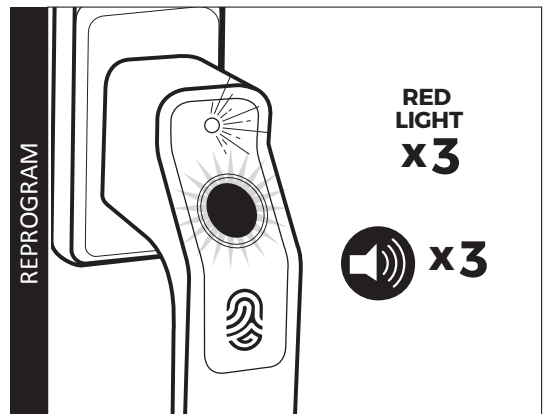

8. PROGRAMMING ADDITIONAL FINGERPRINTS

When accessing your safe quickly, there is a chance you might touch the scanner with a part of your finger that you have not programmed before. For this reason, we recommend programming additional areas of your fingerprint to ensure fast and reliable entry to your safe.

INDIVIDUALLY MAPPING ALL ZONES OF YOUR FINGERPRINT WILL ENSURE A RELIABLE READING BY THE SCANNER.

To ensure each programming sequence is properly captured, the scanner needs to read the exact same place on your finger four times in a row.

This counts as one programmed fingerprint of the 100 fingerprints this unit can keep in memory.

Once programming sequence has been successfully completed you can move onto the next zone of your fingerprint.

Complete section 6 again for each fingerprint zone you would like to program.

NOTE:

If you experience any problems reading your fingerprint, including inconsistent readings, note the area of your fingerprint that doesn't work properly, and specifically reprogram that area.

This scanner will hold up to 100 different fingerprints.

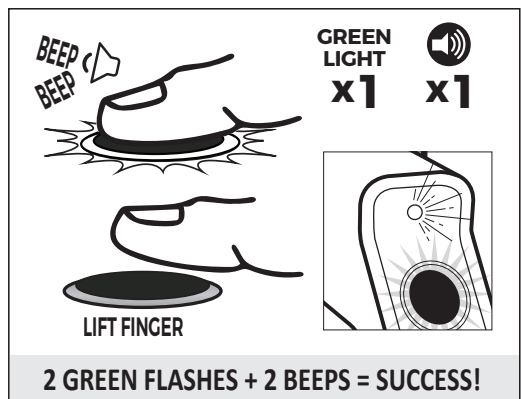
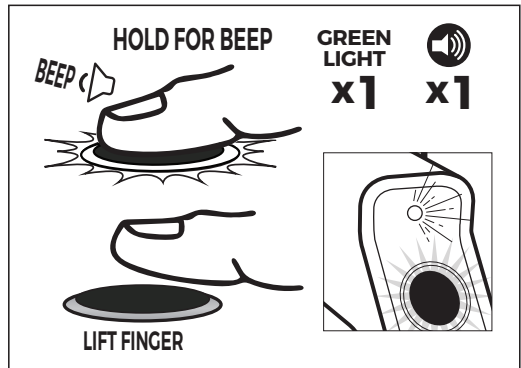
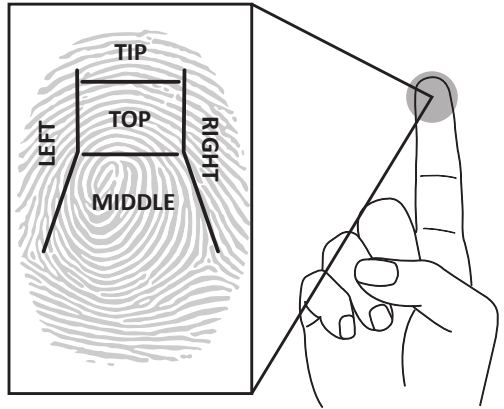

9. TROUBLESHOOTING

In the event that you run into issues with programming and accessing your safe, please read through this section for answers to your questions.

PROBLEM	SOLUTION
THE SCANNER IS NOT READING YOUR FINGERPRINT	Make sure to hold down your finger on the scanner instead of tapping. Scanner needs time to complete the scanning process.
	Fingerprints may lack definition due to excessive skin dryness. We recommend applying moisturizer or slide your fingerprint against your forehead before scanning process.
YOUR PROGRAMMED FINGERPRINT IS NOT READING AT ALL TIMES	Placing a portion of a fingerprint on the scanner that has not been programmed can result in an error. We recommend programming multiple areas of each fingerprint.

Low Battery Indicator

When opening your safe, the light at the top of the handle may turn yellow. This means your safe has entered low battery status. Replace batteries immediately to avoid being locked out of your safe.

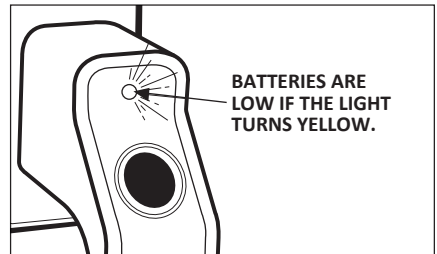

9. TROUBLESHOOTING (Continued)

Locked Out Of Your Safe

In the event you are locked out of your safe, use your backup keys to gain access and follow the section 5 Initial Entry instructions.

If you have lost your backup keys, or are still having any difficulties, contact customer service. Proof of purchase is required to obtain keys.

Safes & More Customer Service - 888-717-4819

10. LOCKOUT MODE / TAMPER PROTECTION



1. Three consecutive rejected scans put the safe in "Basic Lockout" mode. Scanner is deactivated for 1 minute.

3 Sounds and pulsing red light for 1-minute duration. 1 Green light flash and 1 beep once lockout is over.

2. Six consecutive rejected scans result in "Severe Lockout" mode.

Scanner is deactivated for 5 minutes.

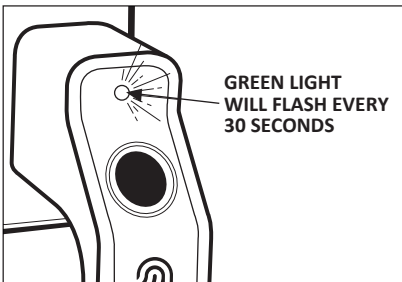

Basic Lockout Mode will also activate the tamper indicator, which provides a visual warning to the safe owner that the safe has been tampered with.

A green light will flash every 30 seconds for the next two hours following lockout mode serving as a warning to the user that entry to the safe has been attempted and unsuccessful.

11. CLEARING ALL RECORDED FINGERPRINTS

Hold Reset button. Initially, the indicator ring and LED light will flash green and beep once. Continue holding reset button for 5 seconds, the LED light will flash green 10 times and beep 10 times.

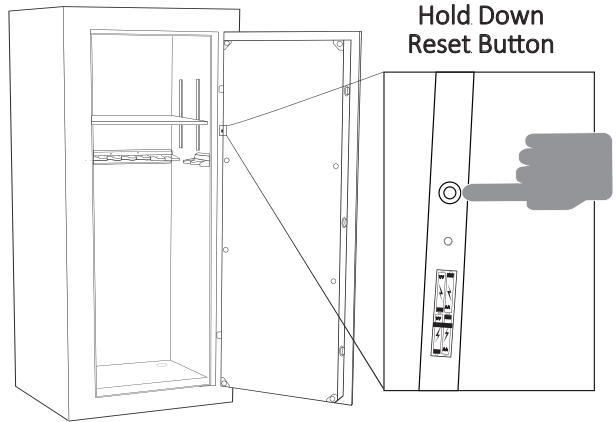

NOTE:

If 100 max fingerprints have already been programmed indicator ring will flash 5 times and beep 5 times. We recommend clearing all programmed fingerprints and starting the programming process over.

12. SILENT ENTRY MODE

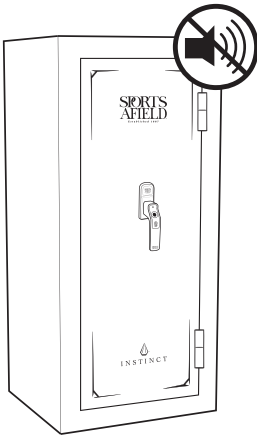

To initiate silent entry mode, hold a programmed finger on the scanner for 5 seconds beyond your fingerprint being accepted. The green indicator ring will turn off and back on, but will not beep, indicating you are now in silent entry mode.

You will not hear any sounds for any functions while the safe is in silent entry mode.

To turn the sound back on, hold a programmed finger on the scanner for 5 seconds beyond your fingerprint being accepted. The green indicator ring will turn off and back on and will beep once indicating you are no longer in silent entry mode.

13. KEEPING YOUR SAFE DRY

We recommend placing a moisture/protective barrier between your safe and concrete floor to prevent any moisture, mildew and rust damage the safe. Installing your safe in a place with climate control (heat in the winter and cooling in the summer) is highly recommended. In areas of high humidity or frequent temperature fluctuations (garages) it is recommend to take appropriate precautions to ward against moisture damage. We strongly encourage the use of an internal dehumidifier and/or desiccants to protect your contents from rust or mildew. Internal dehumidifiers should not be in direct contact with the side or back walls.

14. PROPER PLACEMENT AND MOVING OF SAFE

WARNING: SAFES ARE VERY HEAVY AND AWKWARD TO HANDLE. PLEASE USE THE UTMOST CARE IN MOVING THE SAFE. UTILIZING A TRAINED PROFESSIONAL WITH PROPER MOVING EQUIPMENT IS HIGHLY RECOMMENDED.

The location of the gun safe is very important and the utmost care should be taken during this consideration.

1. To maximize the fire protection of your safe, we recommend you place the safe in lower levels in your home where fire temperatures are lower and away from highly combustible materials.
2. To maximize burglary protection and stability, securing the safe to the floor is recommended.
3. SA Consumer Products recommends that you store your safe in a closet, office, basement, bedroom or any other location that is convenient for you but out of direct line of sight from prying eyes. The location of the gun safe is very important.
4. SA Consumer Products requires the safe is secured to the floor to ensure safe does not tip over in case of a flood.

Using a dolly capable of supporting the size and weight of your safe, move the safe to your desired location. Please take all necessary precautions to protect and prevent any damage to your flooring.

HELPFUL: TO DETERMINE WHETHER YOUR SAFE WILL MAKE IT THROUGH DOORWAYS, STAIRS, OR CORNERS, TAKE THE EMPTY SAFE BOX AND SEE IF IT WILL FIT ALL THE WAY THROUGH TO ITS FINAL LOCATION.

5. The safe should be installed adjacent to a side wall with minimal space on either side of the safe. Wherever possible, the safe should be flat against the wall and floor. Remove the baseboard and/or wall trim if necessary.
6. Always ensure the safe is in an isolated and dry area. Never place the safe in direct contact with a wet floor. When installing your safe on a concrete floor, use of a moisture/protective barrier is highly recommended. Failure to do so, or exposing the safe to chemicals or other adverse environments, may void the warranty.
7. If your safe seems unlevel, you may need to shim the bottom of the safe to prevent the door from swinging open too quickly, or closing on itself.

15. SHIPPING AND SKID REMOVAL

WARNING: WHILE REMOVING THE BOLTS FROM THE SKIDS, BE SURE TO HAVE A PERSON HOLD AND STABILIZE THE SAFE TO KEEP IT FROM TIPPING, CAUSING INJURY, AND/OR DAMAGE TO THE SAFE AND SURROUNDING STRUCTURES.

WARNING: BEFORE REMOVING THE SHIPPING SKIDS, MAKE SURE THE DOOR IS CLOSED AND LOCKED. THE DOOR OF YOUR SAFE IS HEAVY AND PRESENTS A SAFETY HAZARD UNTIL THE SAFE IS BOLTED DOWN OR SECURED PROPERLY.

1. Upon receiving your safe, you may find it attached to a shipping skid. The skid is secured from the underside of the safe by four bolts. Remove the four bolts that secure the safe to the skids using a wrench or 11/16" (17mm) socket.
2. With a person stabilizing the safe, carefully tilt the safe to the left and pull the shipping skid on the right side away from the bottom of the safe.
3. With the shipping skid removed from one side of the safe, carefully lower the safe to the floor.
4. Follow the same procedure to remove the remaining shipping skid.

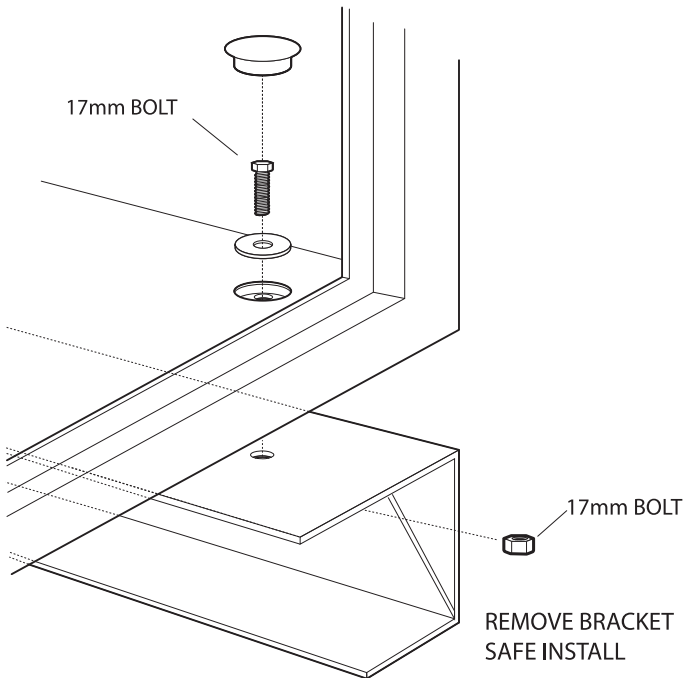

16 SECURING YOUR SAFE

WARNING: YOUR SAFE IS DESIGNED TO SUPPORT ITSELF WHEN THE DOOR IS OPENED. HOWEVER, CAUTION SHOULD BE USED TO AVOID TIPPING. WHILE SECURING YOUR SAFE BE SURE TO HAVE A SECOND PERSON HOLD AND STABILIZE THE SAFE TO KEEP IT FROM TIPPING, CAUSING INJURY, AND/OR DAMAGE TO THE SAFE AND SURROUNDING STRUCTURES. FAILURE TO DO SO WILL COMPROMISE THE SAFETY, SECURITY, AND WARRANTY OF THE SAFE.

TOOLS NEEDED TO BOLT SAFE TO A CONCRETE SURFACE

- DRILL / HAMMER DRILL
- DRILL BIT – 1/2" (for installing into concrete with provided hardware)
- WRENCH / 11/16" (17MM) SOCKET
- HAMMER
- SAFETY GLASSES
- GLOVES
- OTHER SAFETY EQUIPMENT AS NEEDED

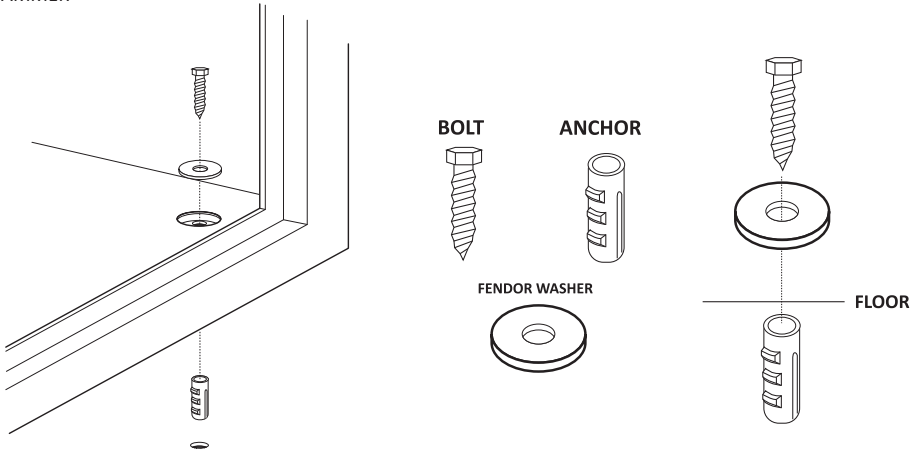

1. Use the hardware provided or consult your hardware retailer for fastening hardware for your particular mounting surface.
2. Open your safe door and locate and remove the four black caps on the safe floor. This will provide access to the factory drilled bolt down holes.
3. To secure your safe to the floor it will first be necessary to drill pilot holes in the floor surface.
4. Drill the appropriate diameter and depth of pilot holes based on the type of hardware being used and the type of floor surface. For the hardware provided (concrete floor installation) we recommend using a hammer drill and 1/2" concrete drill bit to drill holes the four corresponding in the concrete floor.
5. Insert and drive the plastic anchoring plugs into the pilot holes. You may need to use a hammer to fully insert the plugs into the pilot holes.
6. Secure the safe, by threading all 4 anchor bolts through the factory drilled bolt down holes in the bottom of the safe and ratcheting down tight.
 - Make sure the metal washer sits on top of the rubber washer. Tighten the bolt to compress the rubber washer between the safe and metal washer. Failure to do so will allow water to enter the safe in the event of a flood.
7. Replace the four black caps onto the floor of the safe.

17. GUN REST INSTALLATION

1. Locate the gun racks that will be part of your safe assembly kit. Find the pre-drilled drywall anchors that are located on the back and side walls of your safe. Select the ideal location(s) for your gun rack(s) that best fit your custom storage needs.
2. Insert bolts, as shown below, into the two pre-drilled holes in your gun rack, through the drywall anchor on the interior of your safe to secure the gun rack in place.

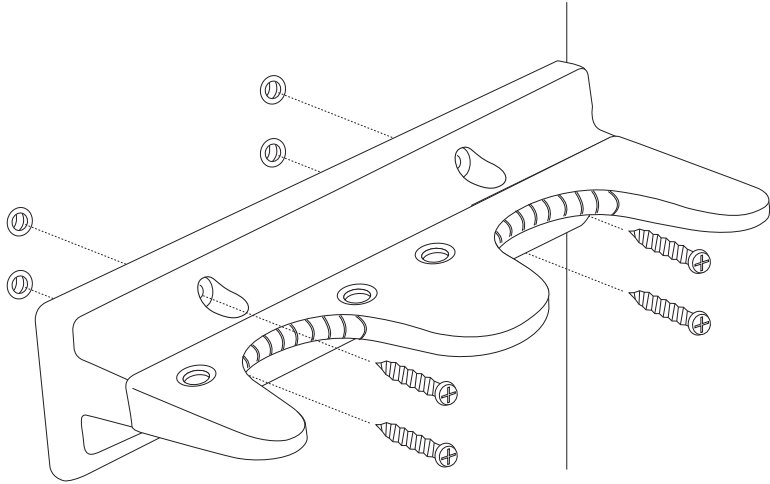

Scoped firearms will require additional clearance from the cabinet walls. Installing Standoffs will distance the scope from the cabinet wall, ensuring no damage to the scope or firearm.

1. Locate the standoffs inside the cabinet assembly kit located inside of your cabinet. Simply clip the two attachment points into the holes located on top of the gun rest to fully secure.

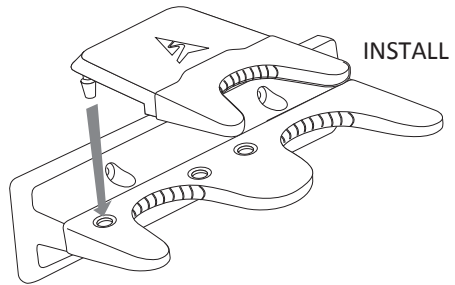

2. Standoffs are designed to clip at any position in any quantity along the gun rest brackets to suit your needs. The standoffs can be easily removed or transitioned to another area by pulling directly up and twisting on the opposite end of the attachment points to safely remove.

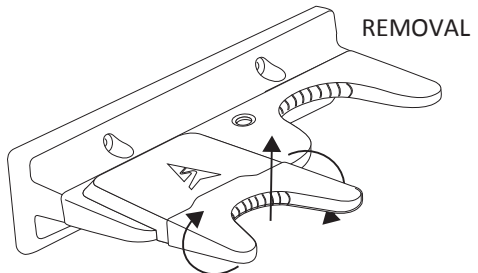

18. LOADING YOUR SAFE

1. Store documents or heat sensitive items in the bottom of the safe for greatest protection against fire damage.
2. Store ammunition separately from valuables.
3. Do not put anything in your safe that will put pressure against the door when it is closed.
4. Select safe models have reinforced shelving, but as a good safety precaution store heavier items either on the floor of the safe, or away from the middle of the shelves.
5. When placing guns into your safe, make sure they rest securely against the cutouts provided in the gun racks to prevent accidental tipping when the door is closed.

19. MAINTENANCE

HINGES AND INTERNAL MECHANISMS

The hinges and internal locking mechanism are permanently lubricated, thus needing no maintenance. Opening the door panel of your safe may void your warranty. Always consult our customer service experts prior to doing so.

LOCKING BOLTS

We recommend greasing active locking bolts with a thin layer of lithium grease every 2-3 months to ensure smooth operation of the locking mechanism.

Distributed by:



SAFESandMORE.com

Text or Call: 888-717-4819

support@safesandmore.com