

Round Cube SINGLE 2.4 / 2.6

Construction guide

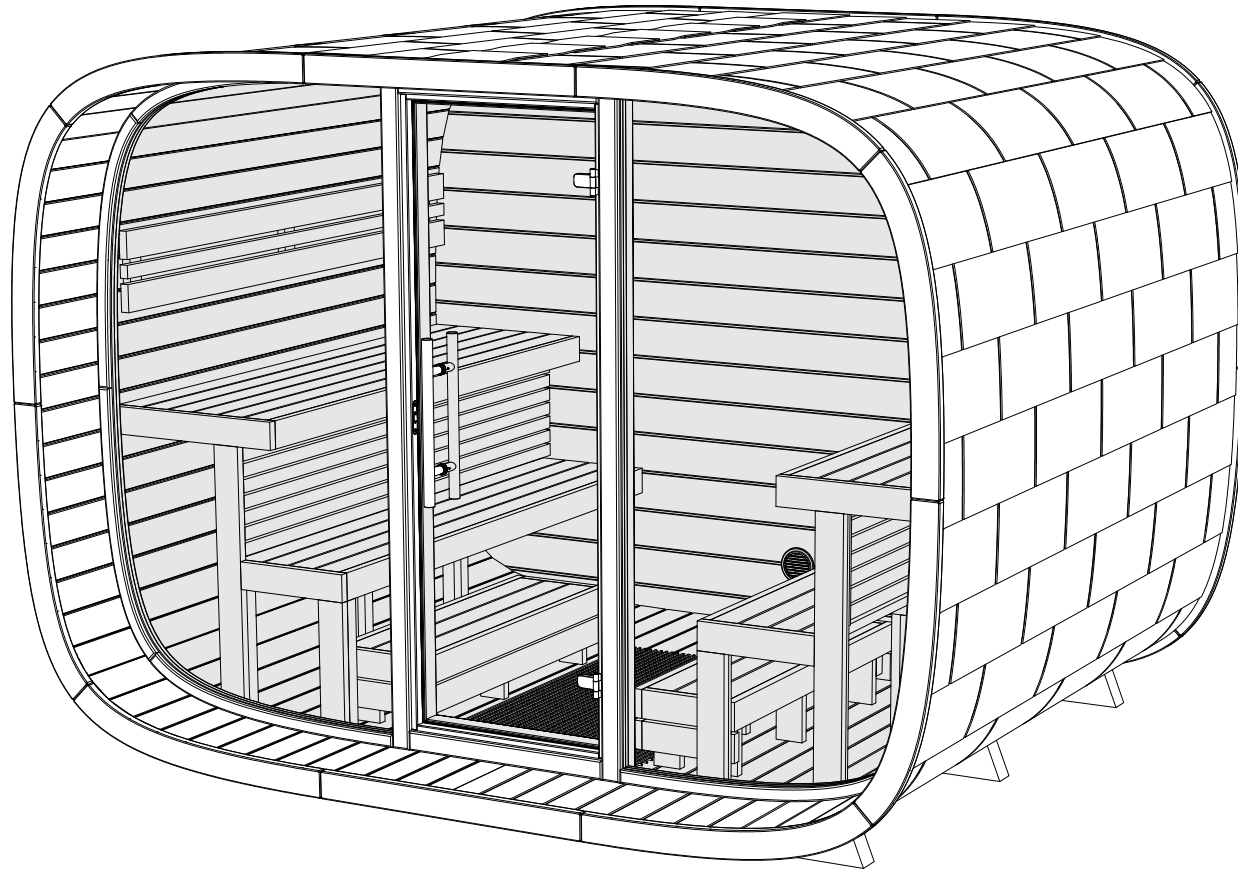

Check the parts for completeness before assembly!

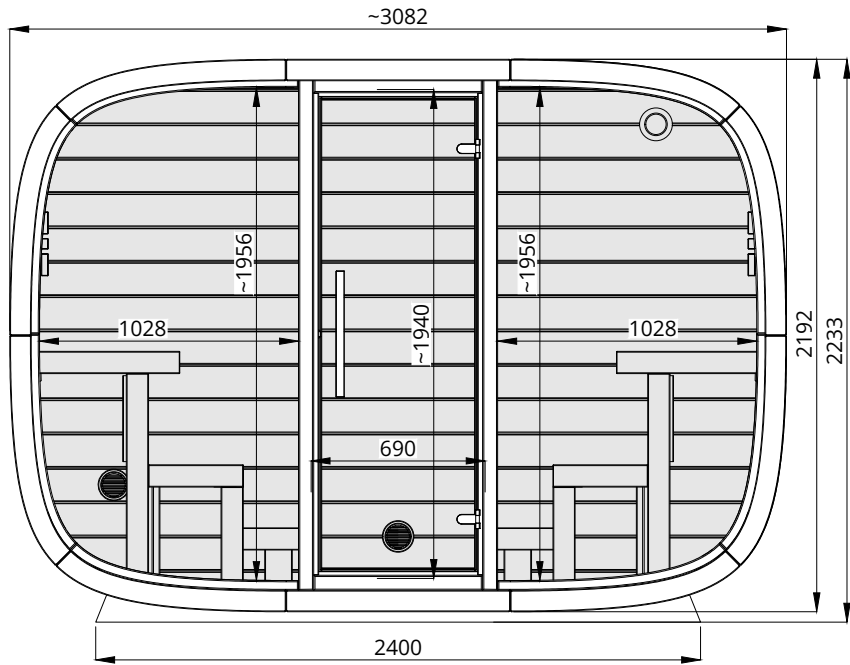

Front view

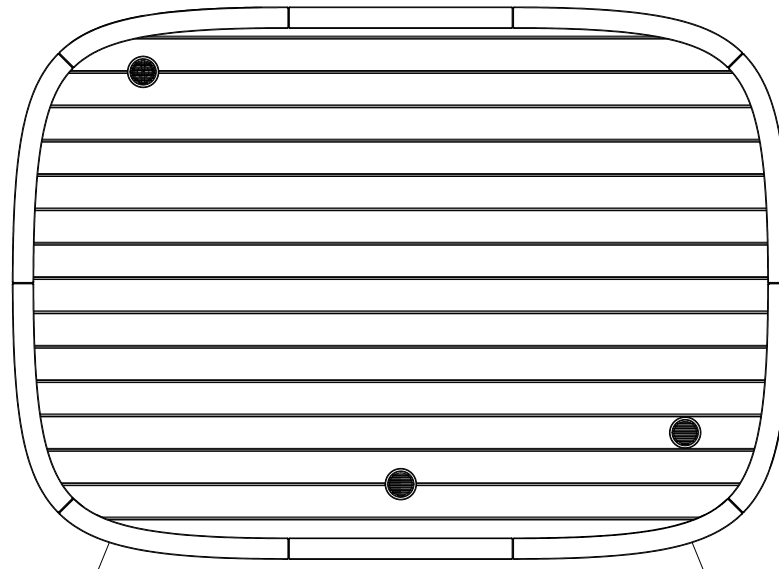
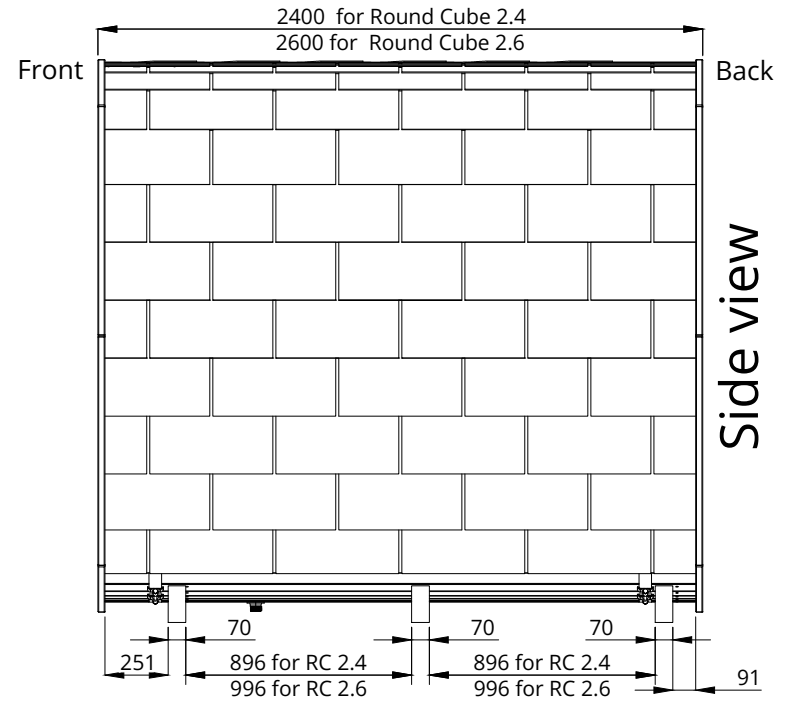

Back view

Scale 1 : 30

Round Cube

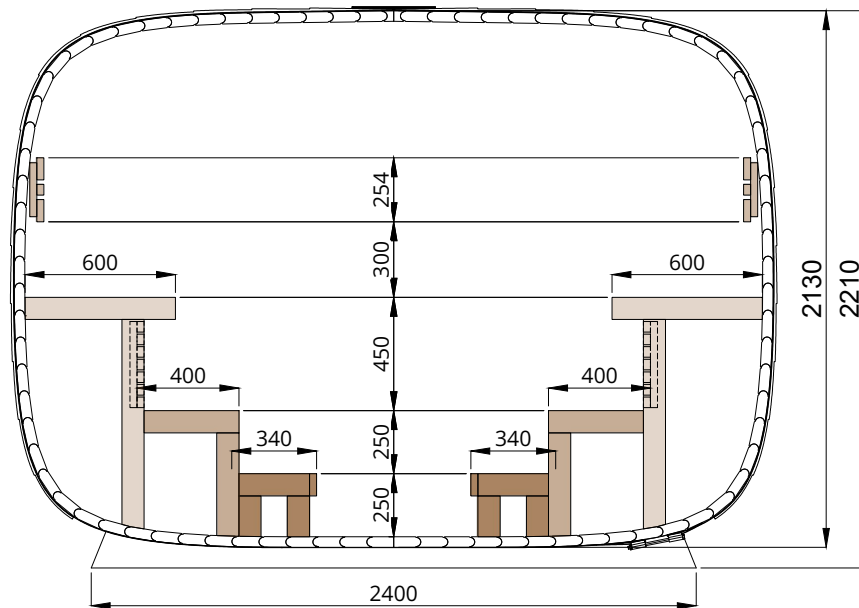
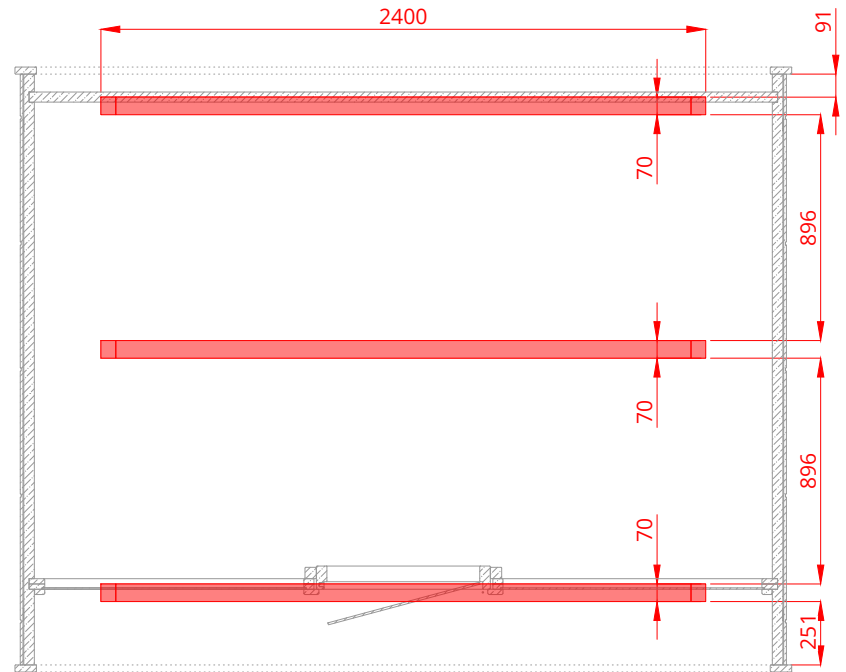
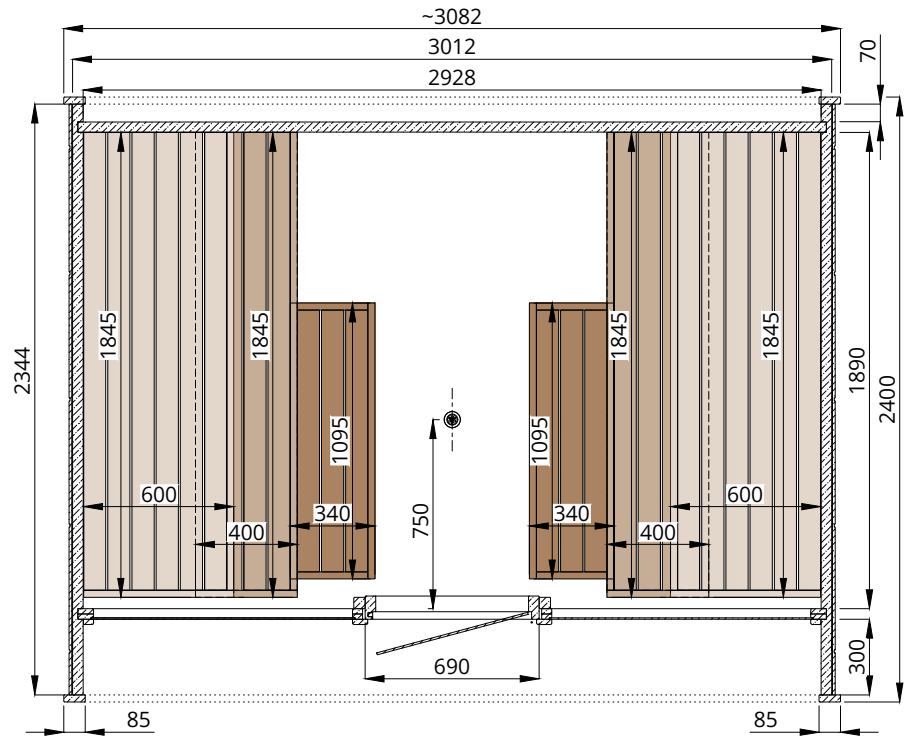

Scale 1 : 30

Round Cube 2.4

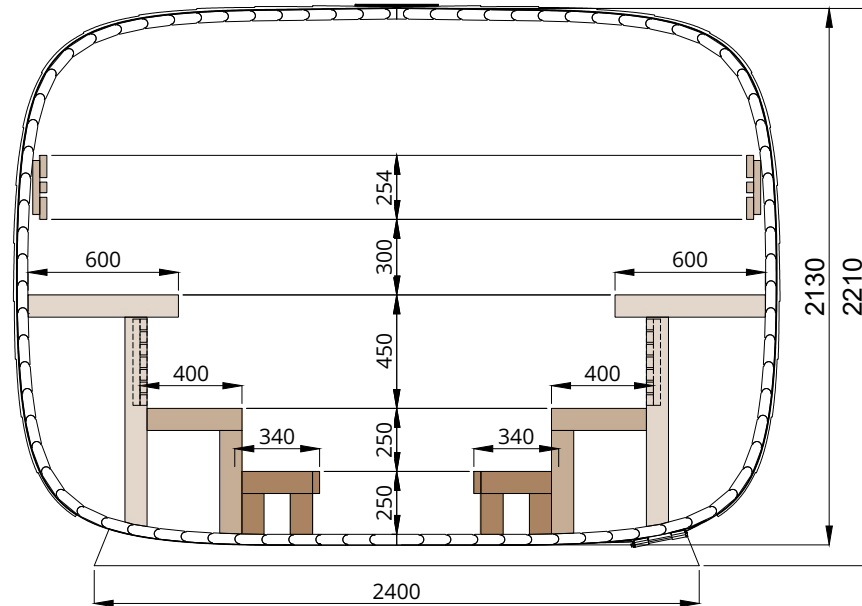
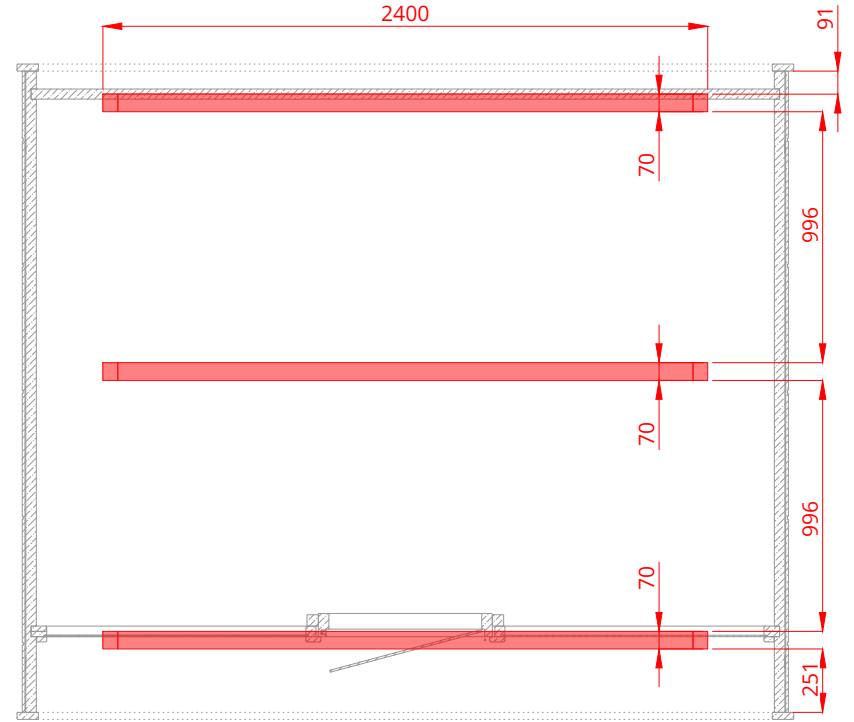
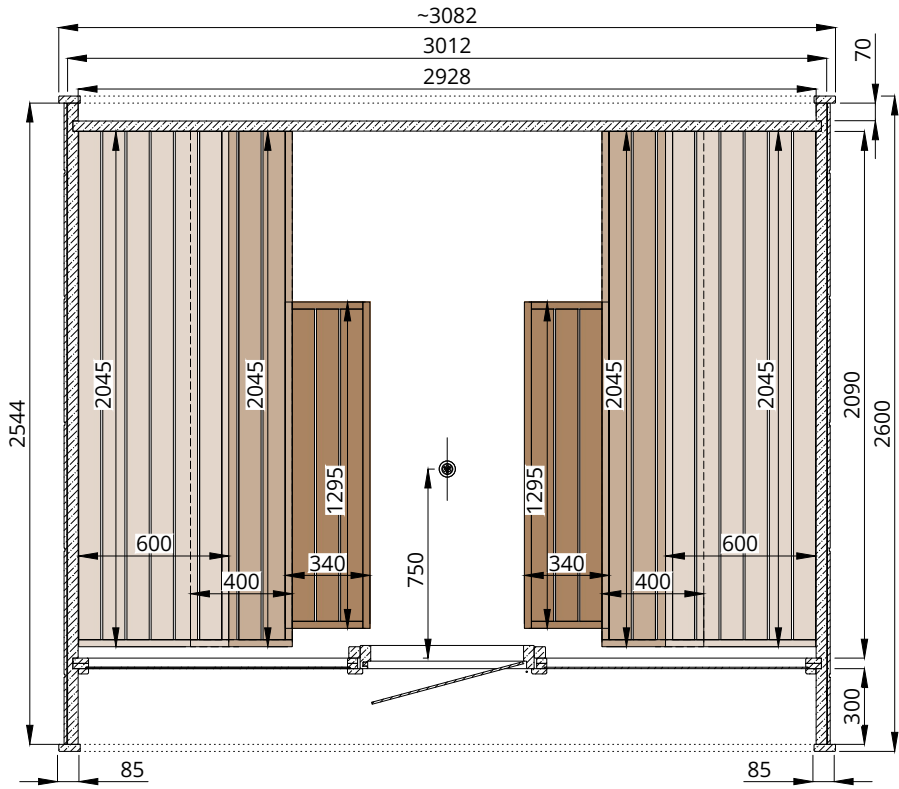

Scale 1 : 30

Round Cube 2.6

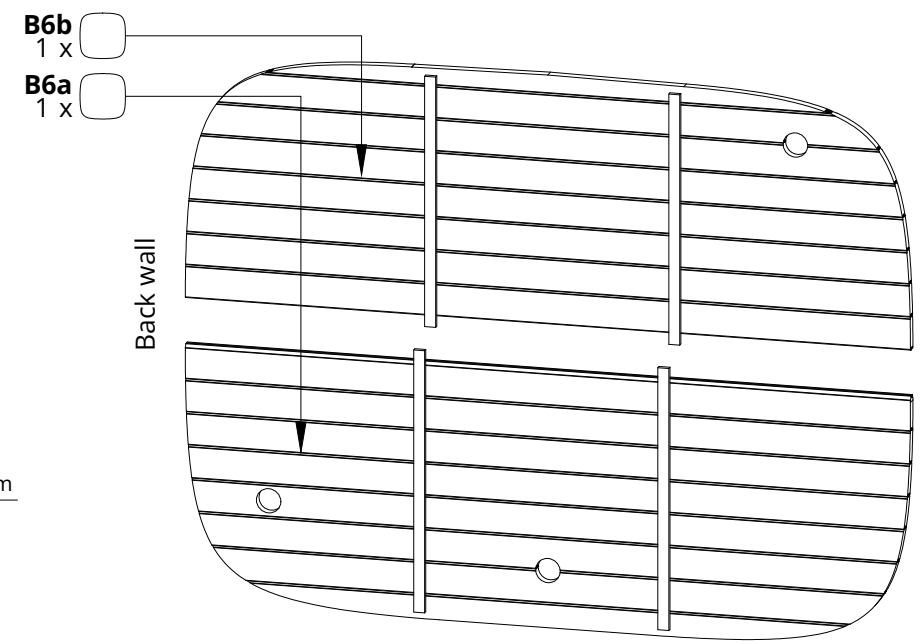
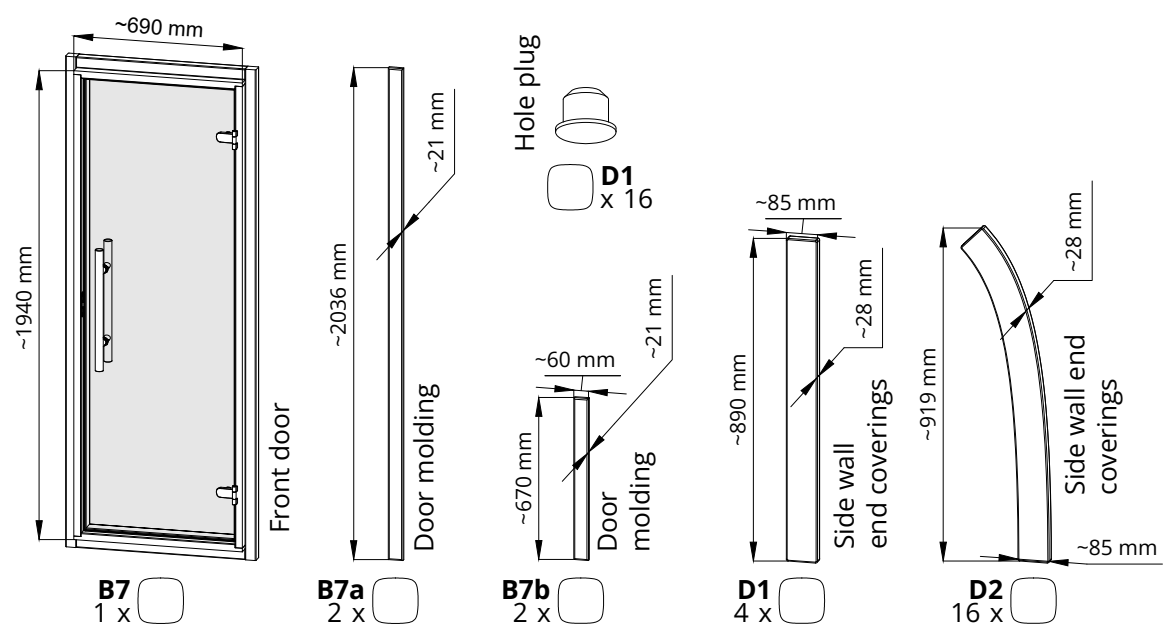
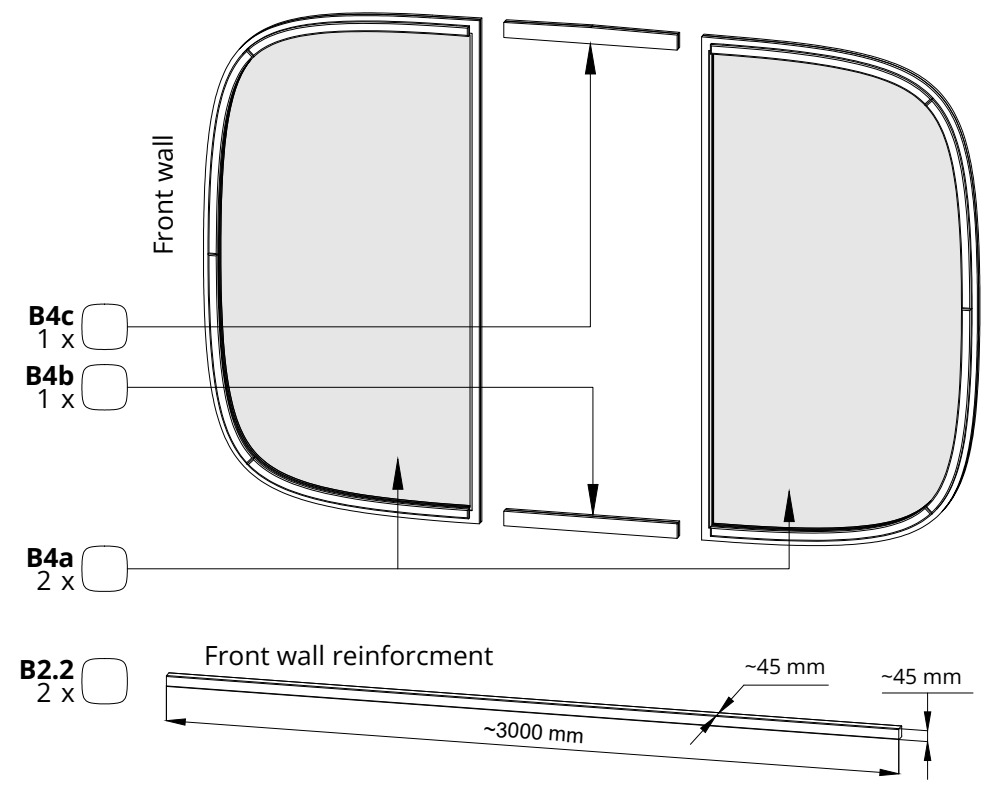
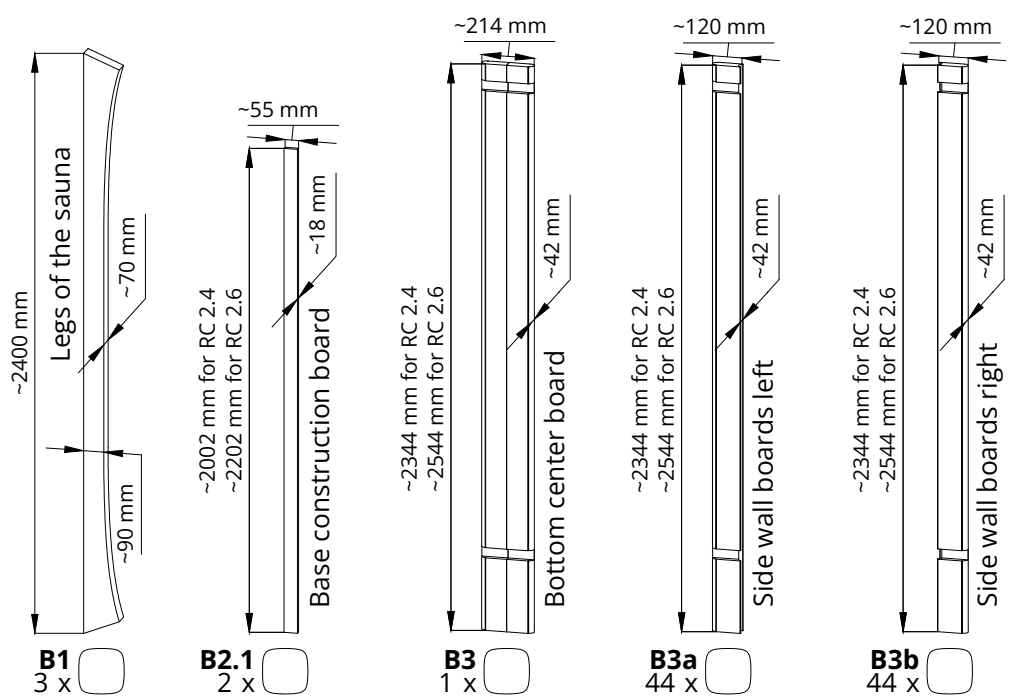



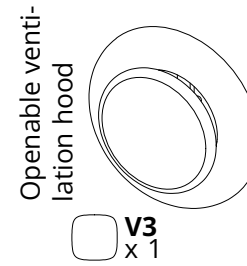
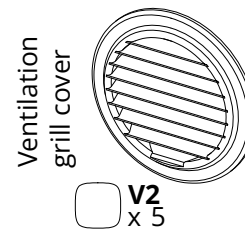
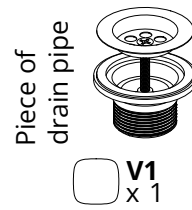
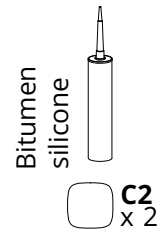
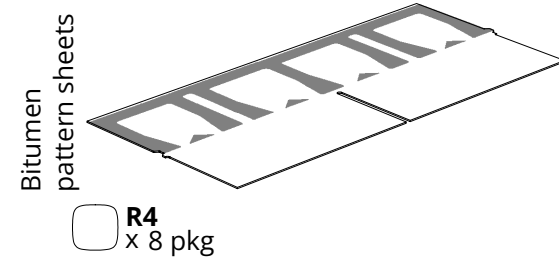
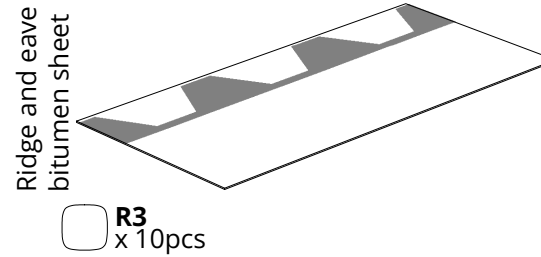
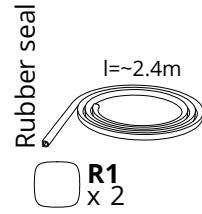
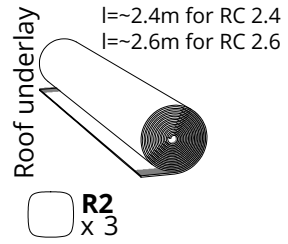
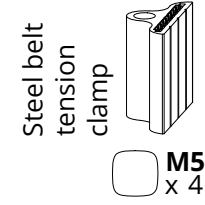
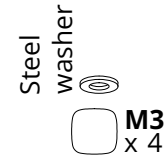
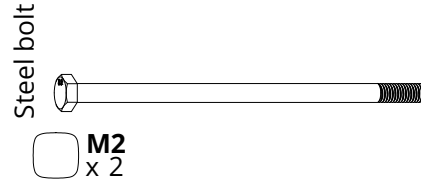
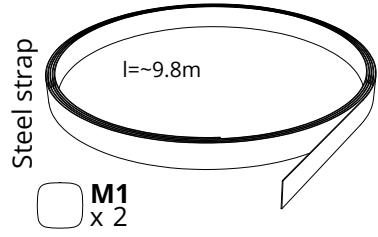

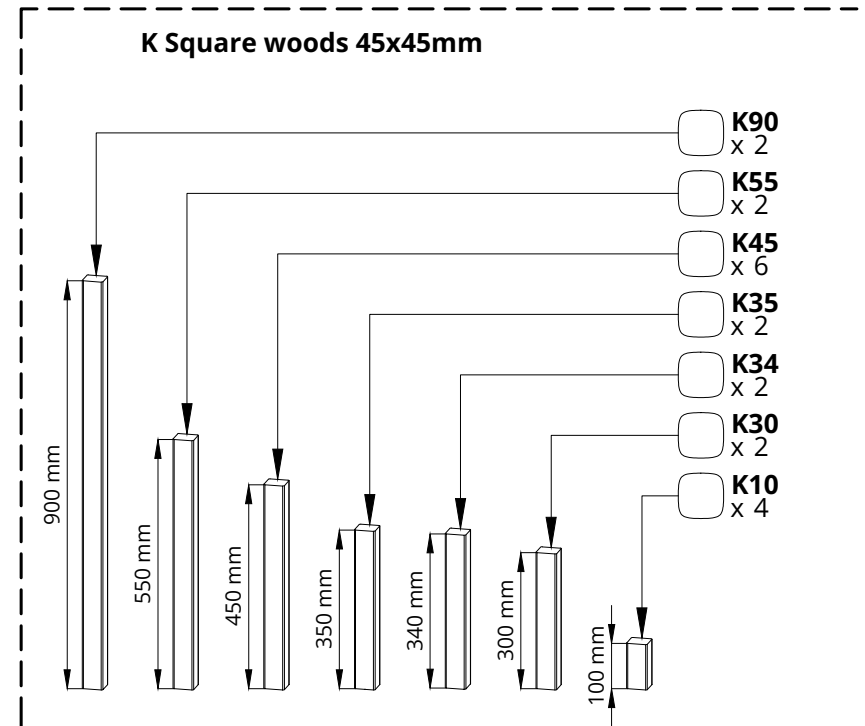
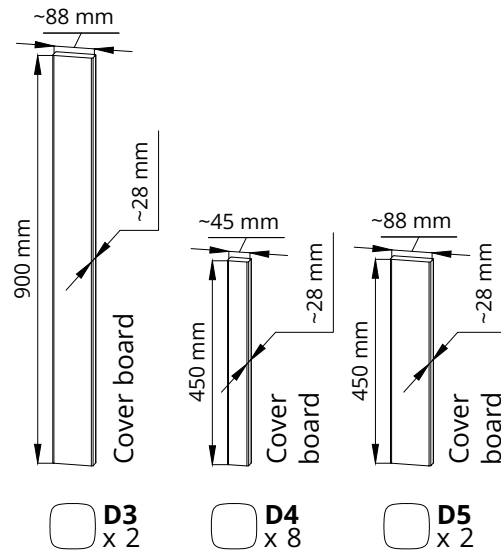
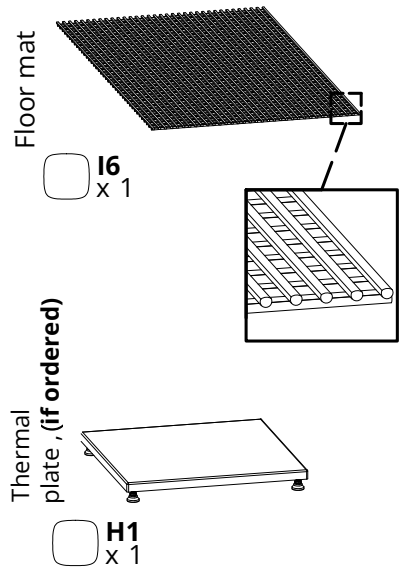
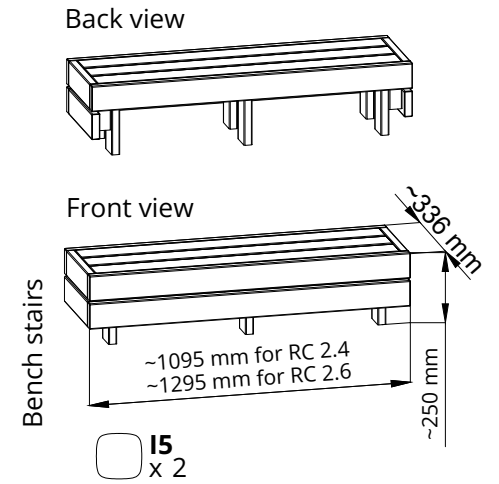
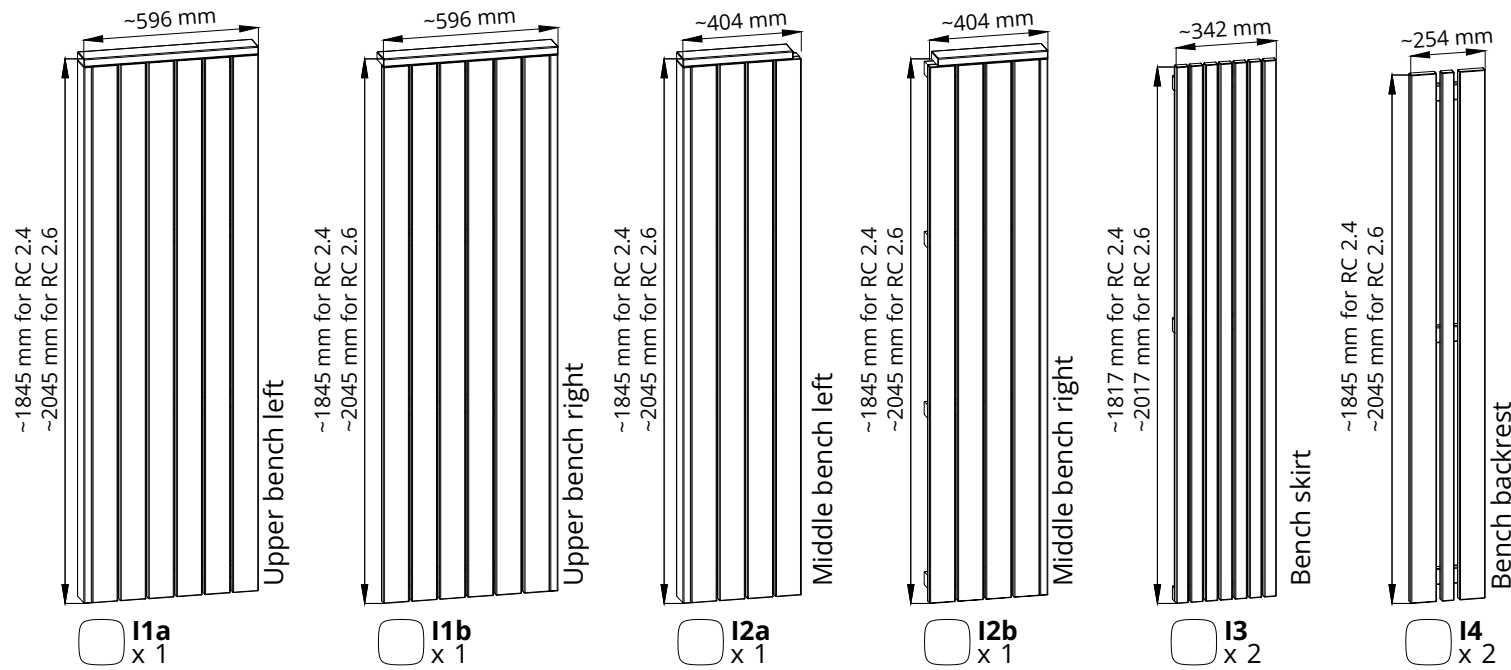

Detail list 1



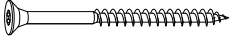
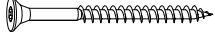
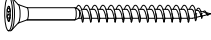
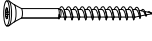
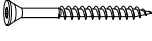
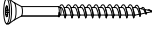
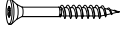

Detail list 3

Nails and screws (Scale 1:2)	Area of use	Name in in. manual	Screw size	Quantity	
	Mainly for construction inside and outside	S7	Screws 4,5x80 for Spruce	x150	<input type="checkbox"/>
			Screws 4,2x75 for Thermo		
	For fixing the door(s)	S6.2	Screws 4,2x75	x25	<input type="checkbox"/>
	For fixing the side wall end coverings	S6.1	Screws 4,5x70 (black coated)	x60	<input type="checkbox"/>
	Mainly for construction inside and outside	S5	Screws 4,5x60 for Spruce	x200	<input type="checkbox"/>
			Screws 4,2x55 for Thermo		
	Not in use in this sauna Only for the window(s)	S4	Screws 4,2x55	x0	<input type="checkbox"/>
	For fixing front door moldings (screws is attached to the door moldings)	S3.2	Screws 4,5x50	x14	<input type="checkbox"/>
	Not in use in this sauna Only for the window moldings	S3.1	Screws 3x40	x0	<input type="checkbox"/>
	Mainly for construction inside and outside	S2	Screws 3x40	x15	<input type="checkbox"/>
	Mainly for construction inside and outside	S1	Screws 3x30	x18	<input type="checkbox"/>
	During roof installation	R5	Nail 2,5x20	1kg	<input type="checkbox"/>

Detail list 4

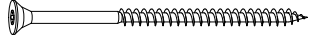
S7	Screws 4,5x80 for Spruce Screws 4,2x75 for Thermo	x6
		

NB! use a level

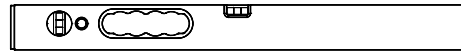

The base of the sauna must be level!

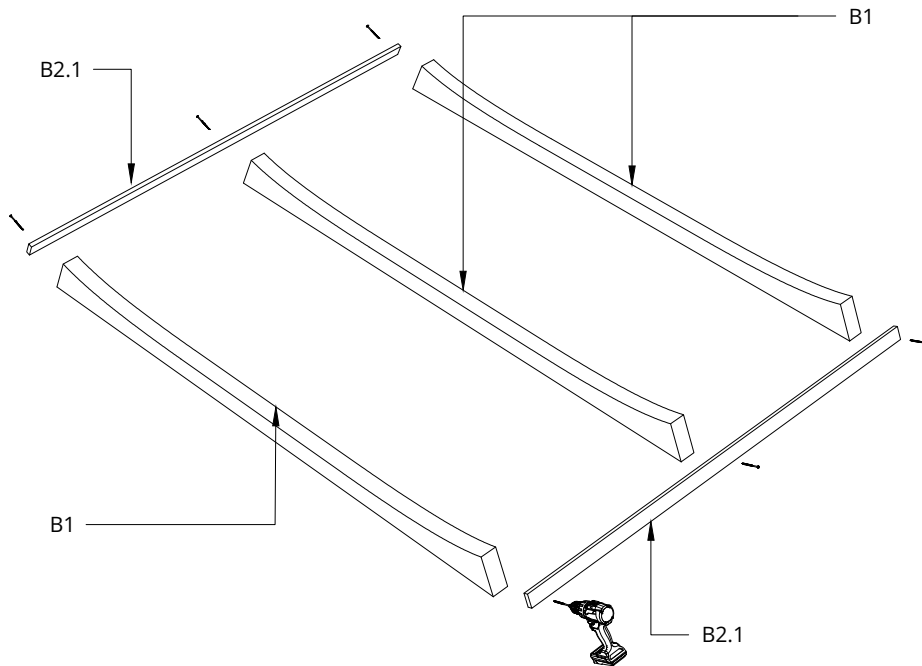
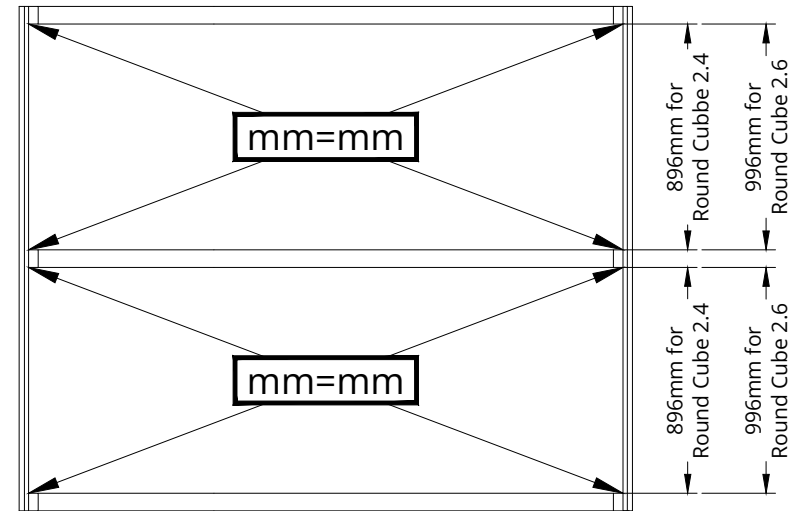

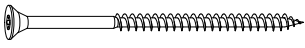
S7	Screws 4,5x80 for Spruce Screws 4,2x75 for Thermo	x6
		

Use two screws for point A1, A2 and A3 (see sketch) .

Please countersink the screw head!

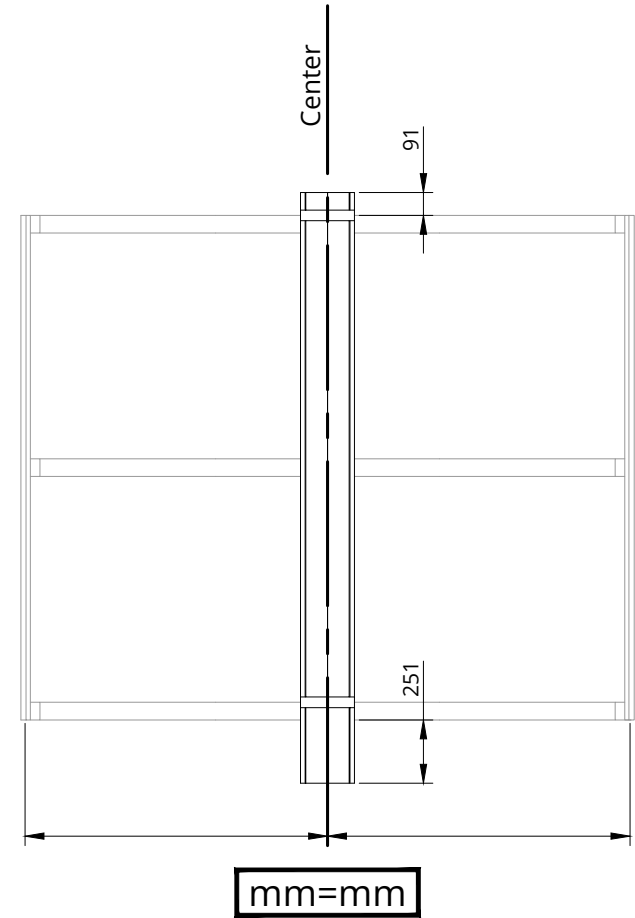
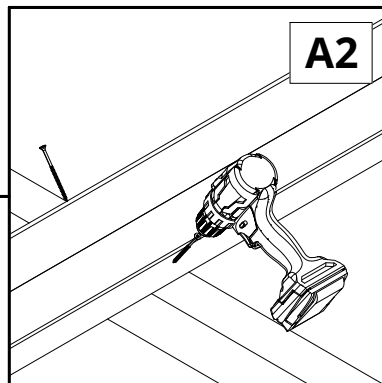
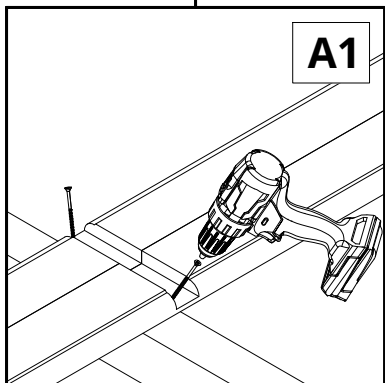
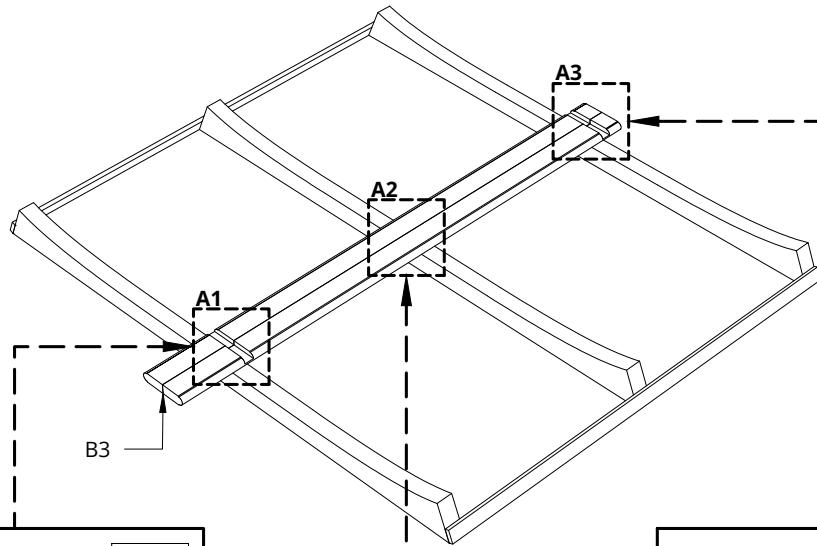
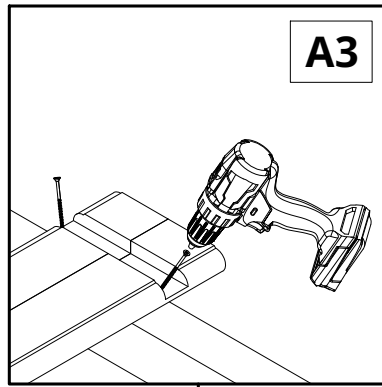

S7	Screws 4,5x80 for Spruce Screws 4,2x75 for Thermo	x60
		

Use a rubber mallet to tap the planks together.

Screw each plank B3a and B3b to the foundation B1 with a screw. ~10 pieces on each side left B3a and right B3b.

Please countersink the screw head!

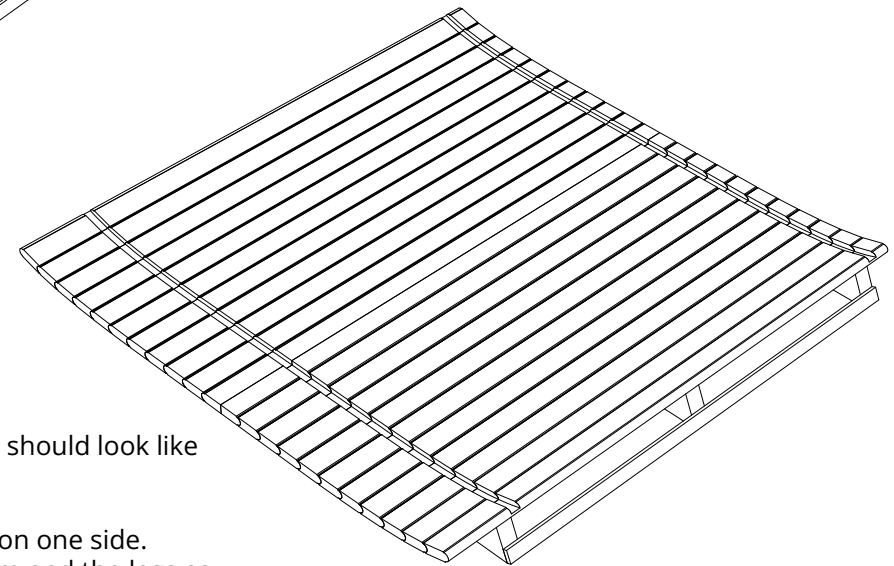
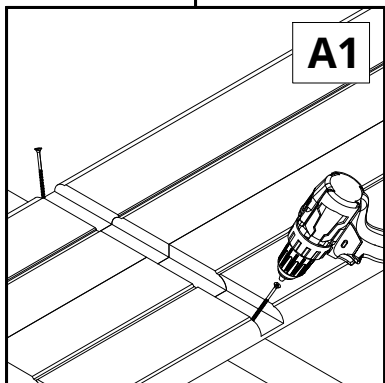
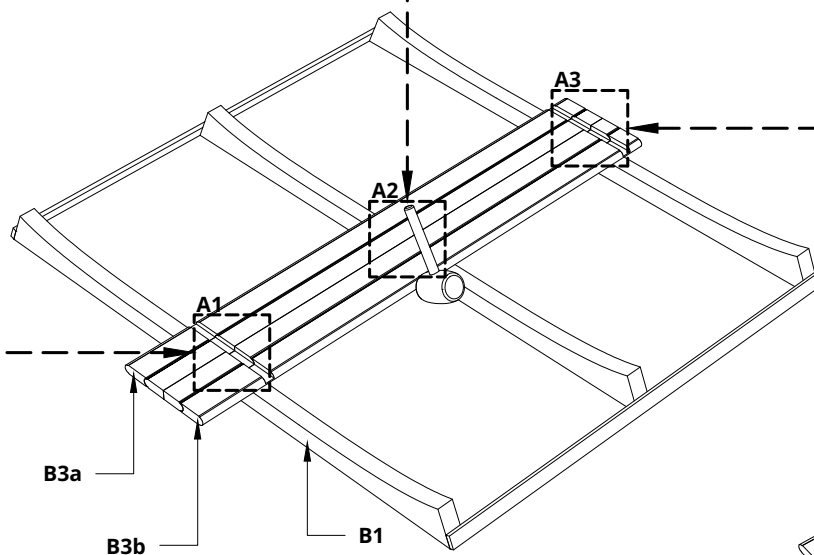
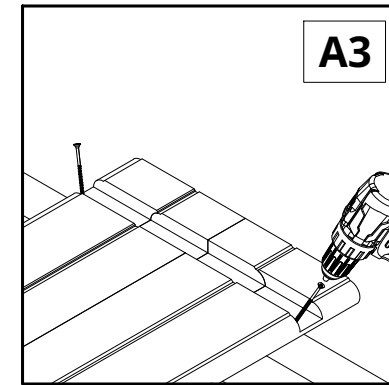
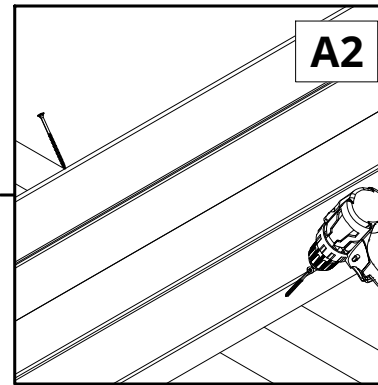

When the boards are installed it should look like this. ~10 boards on each side.

Lift the bottom of the sauna up on one side. Paint the boards from the bottom and the legs as well, with the included **black paint**. Let the paint dry a bit.

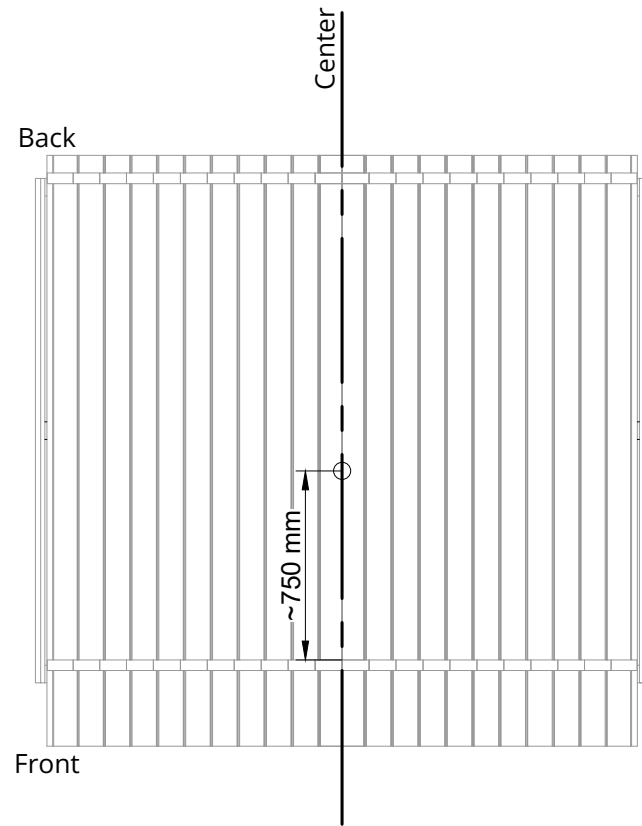

Before installation of the drain pipe, hole must be cut with a hole saw.

Install a piece of drain pipe V1.

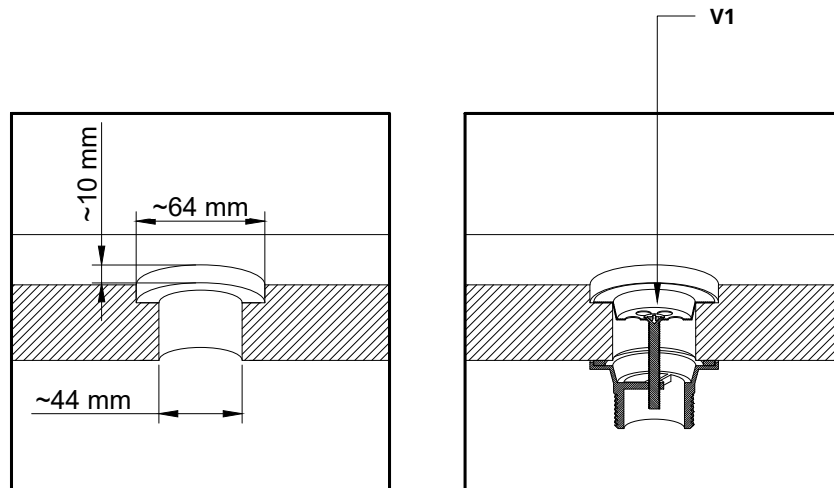
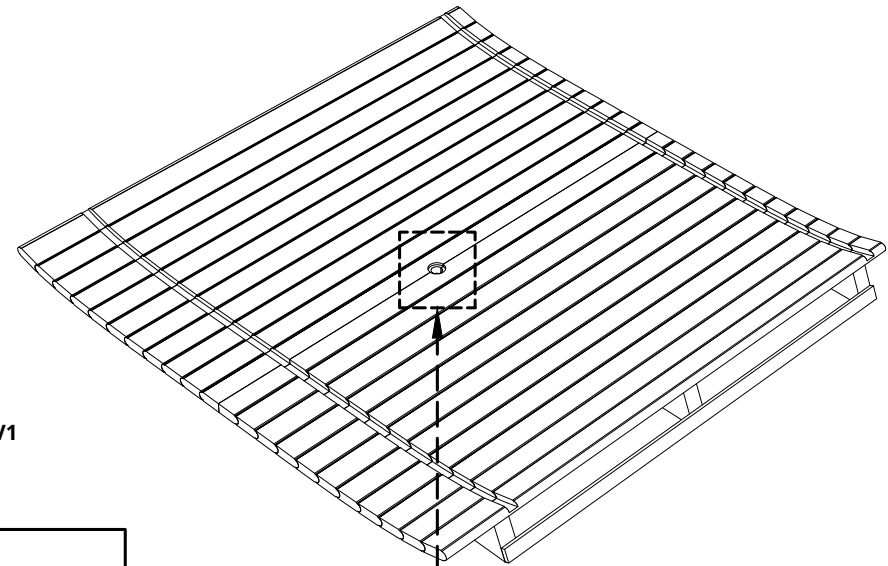



Lay R1 (rubber seal) to the inside of the groove as shown in picture A3 and A4.

Drill 10 mm hole in each plank, in the front wall groove and in the back wall groove to the outside as shown in the picture A1 and A2.

After drilling, **clean the groove from wood debris** and cover the groove with the included **inarijärvi wood treatment** - protects against water and humidity. Let the inarijärvi dry.

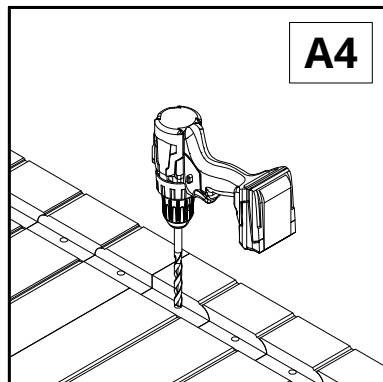
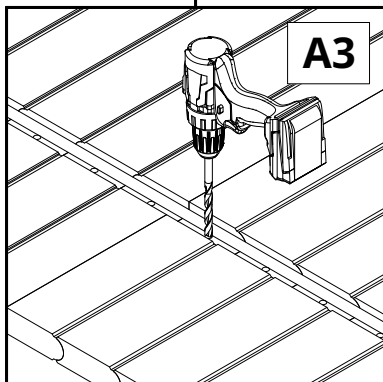
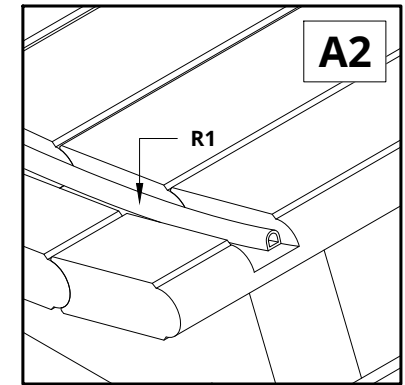
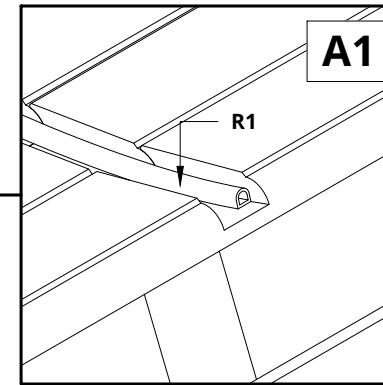
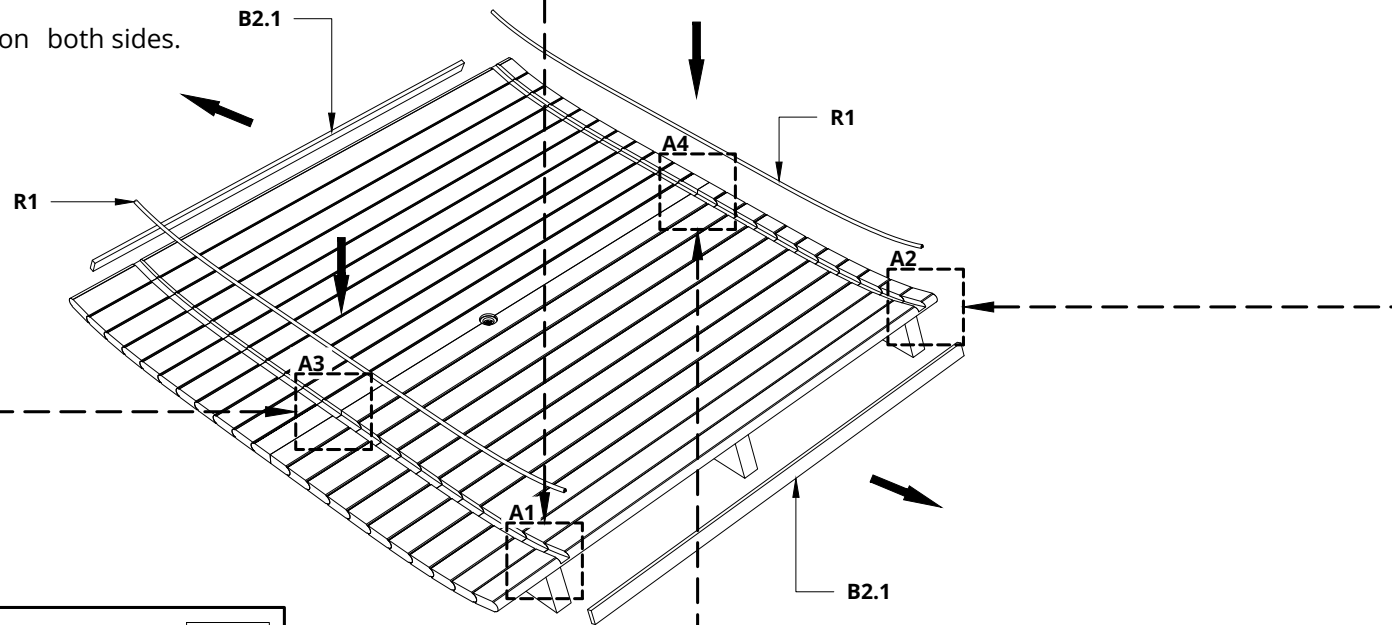
Remove the connecting beam B2.1 on both sides.



S7	Screws 4,5x80 for Spruce Screws 4,2x75 for Thermo	x8
S5	Screws 4,5x60 for Spruce Screws 4,2x55 for Thermo	x4
		

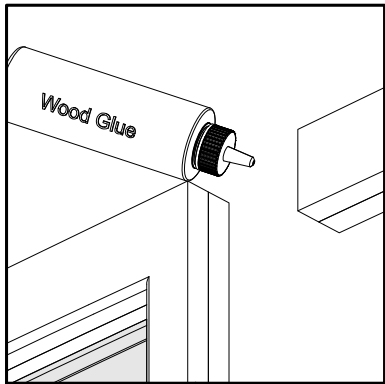



Preparation of the front wall.

When assembling the front wall, first use glue between the wall pieces and then screw the pieces together and add the wall reinforcements B2.2 to the inner side of the wall.

Let the glue dry according to the glue manufacturer's recommendations.

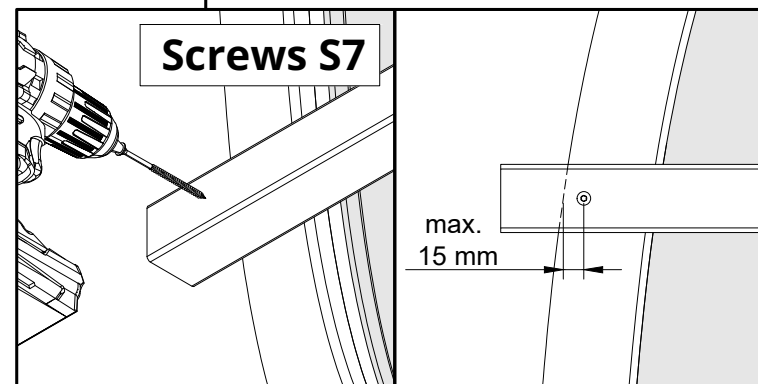
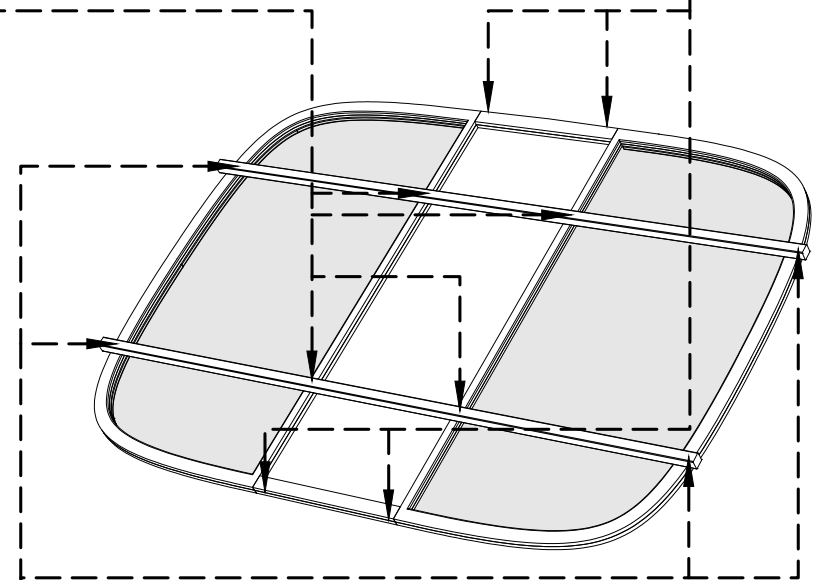
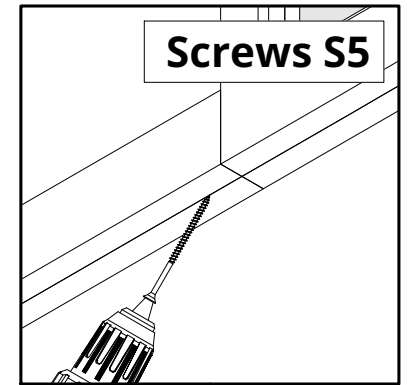
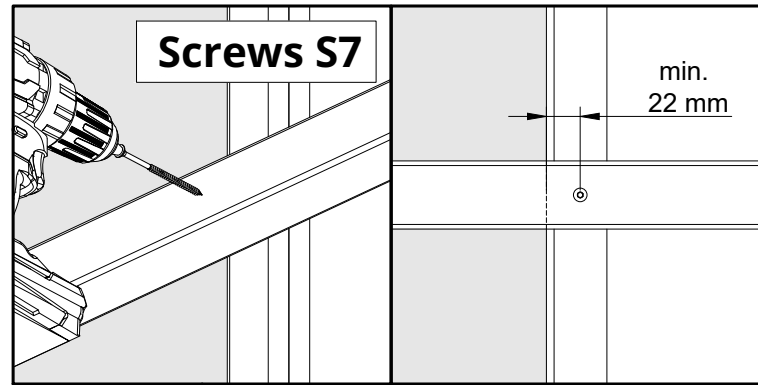
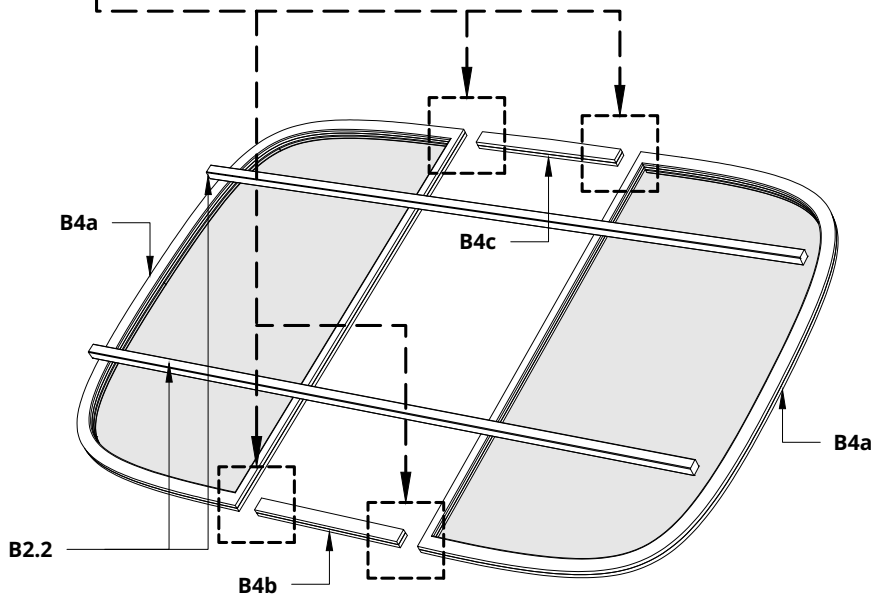
Please countersink the S5 screw head!



S5	Screws 4,5x60 for Spruce Screws 4,2x55 for Thermo	x2
		

NB! use a level

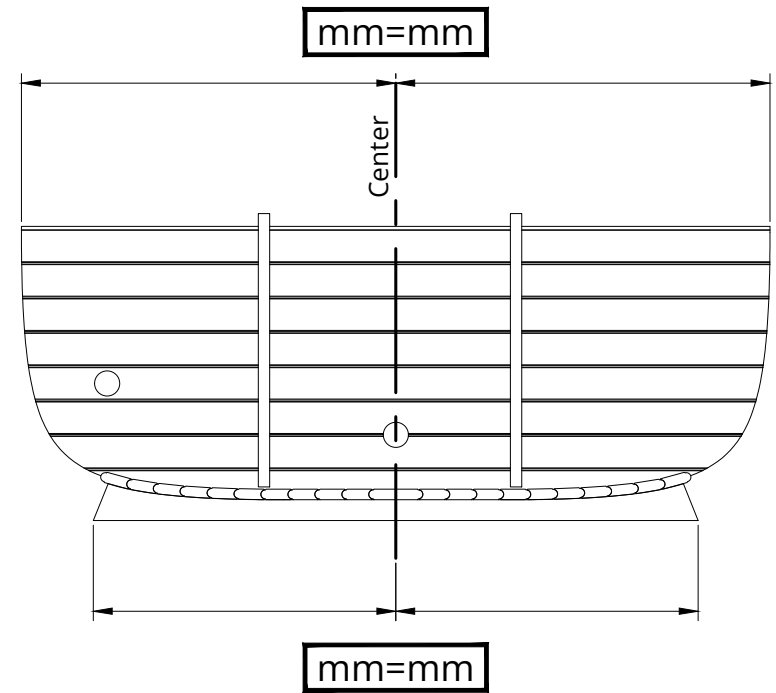
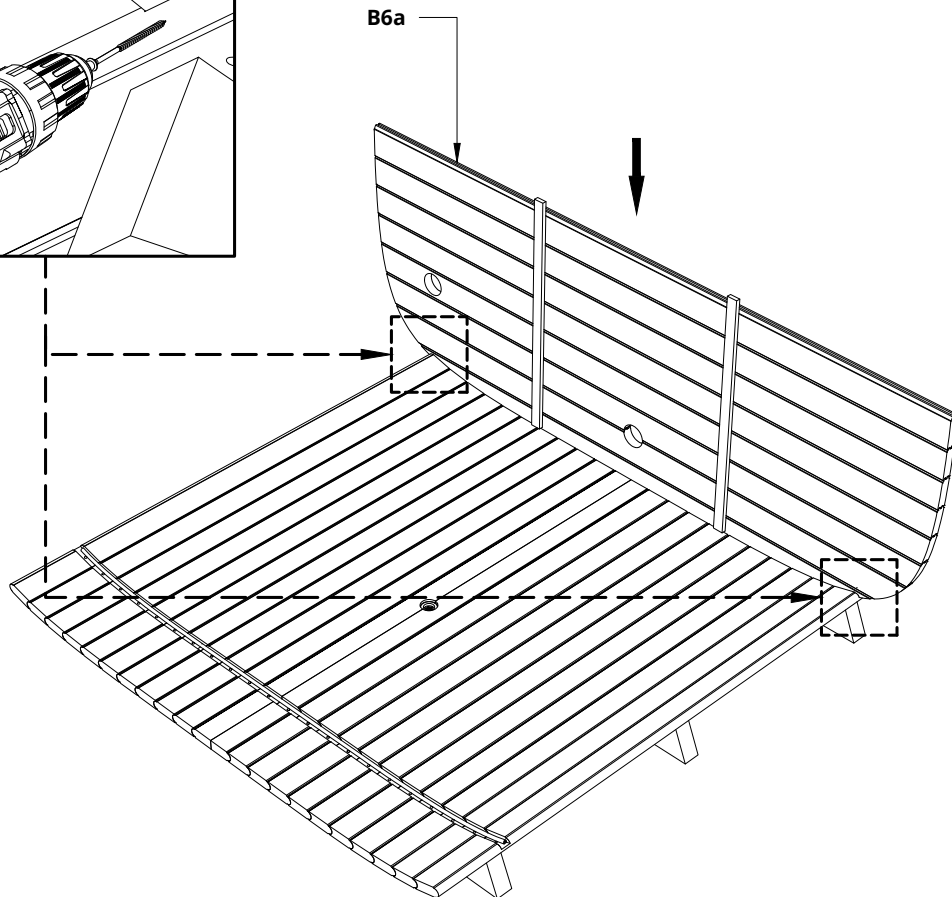
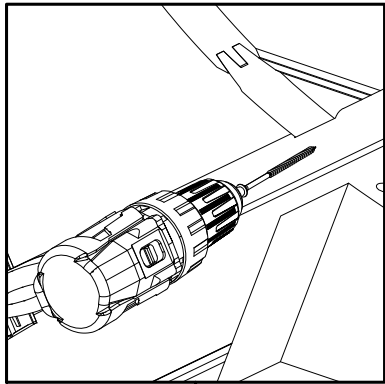
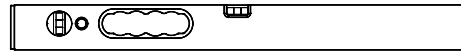

First install the lower part of the back wall. The lower part of the back wall must be in the center of the base.

If the lower part of the back wall is in place, then it must be fixed with screws. The screw locations are shown in the picture.

Please countersink the screw head!

S7	Screws 4,5x80 for Spruce Screws 4,2x75 for Thermo	x4
S5	Screws 4,5x60 for Spruce Screws 4,2x55 for Thermo	x2
		

When installing the front wall, make sure that it stays in the center!

NB! use a level

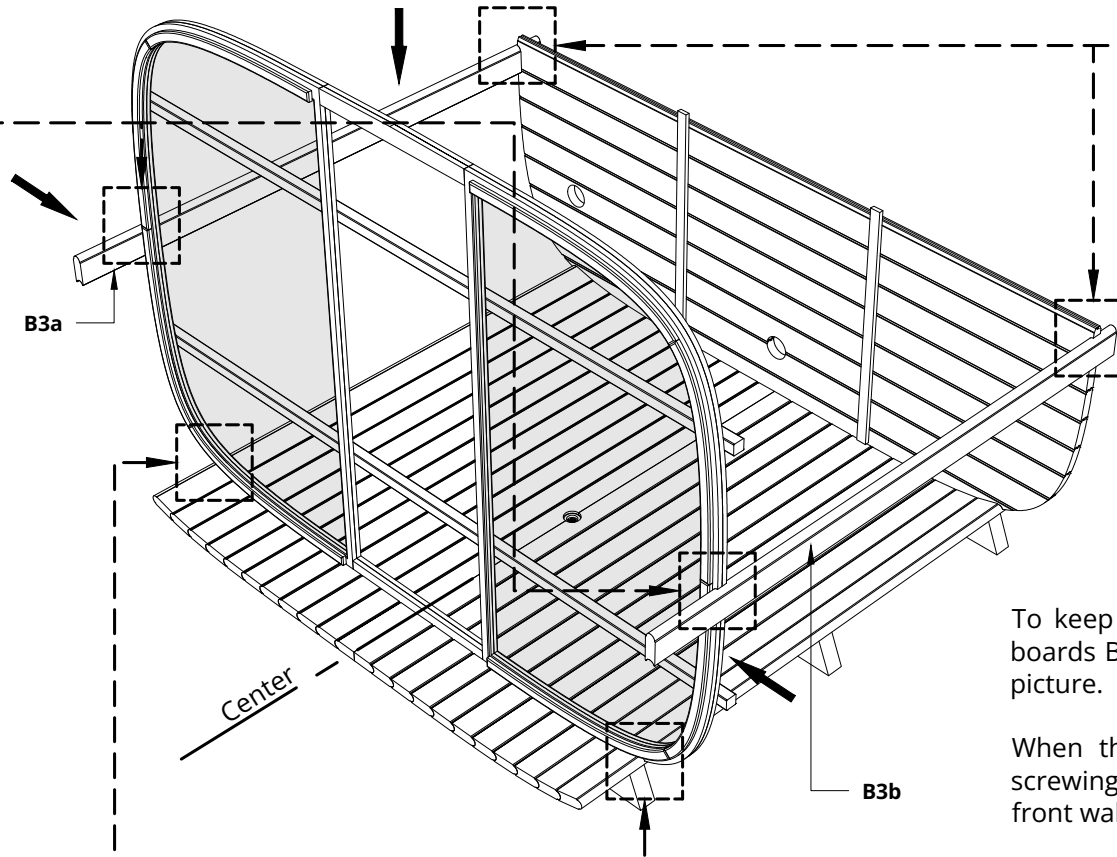
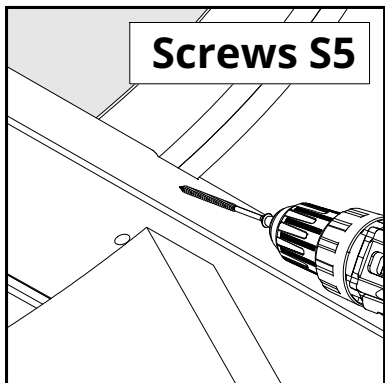
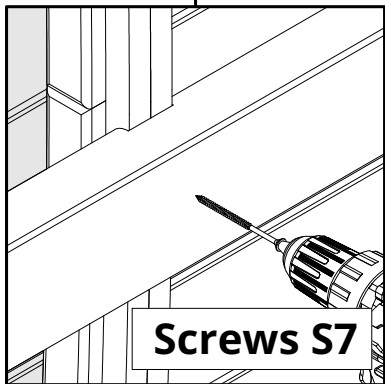
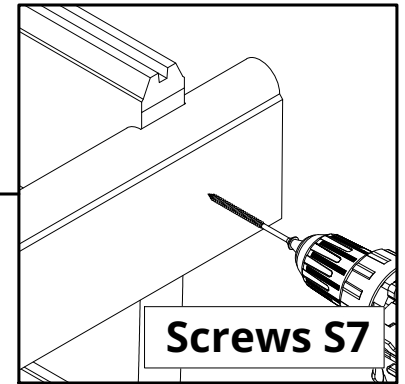
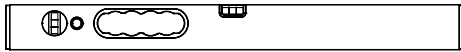

To keep the front wall upright, use the side wall boards B3a and B3b. Install them as shown in the picture.

When the support boards are in place, before screwing the front wall to the base, check if the front wall is in the center.

Please countersink the S5 screw head!

S5	Screws 4,5x60 for Spruce Screws 4,2x55 for Thermo	x40
		

When the front wall is attached, start building the side walls on the left B3a and on the right B3b. Use a rubber mallet to tap the boards into place and then fasten with screws.

Build the side walls to the upper edge of the lower part of the back wall as shown in the picture.

Please countersink the S5 screw head!

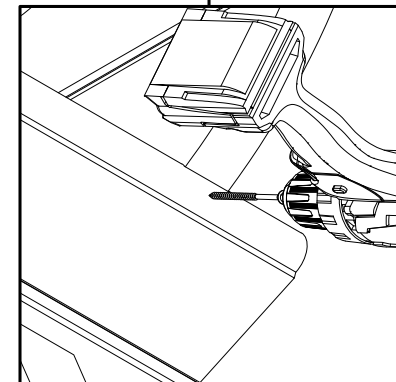
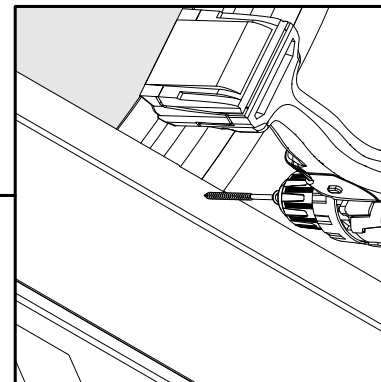
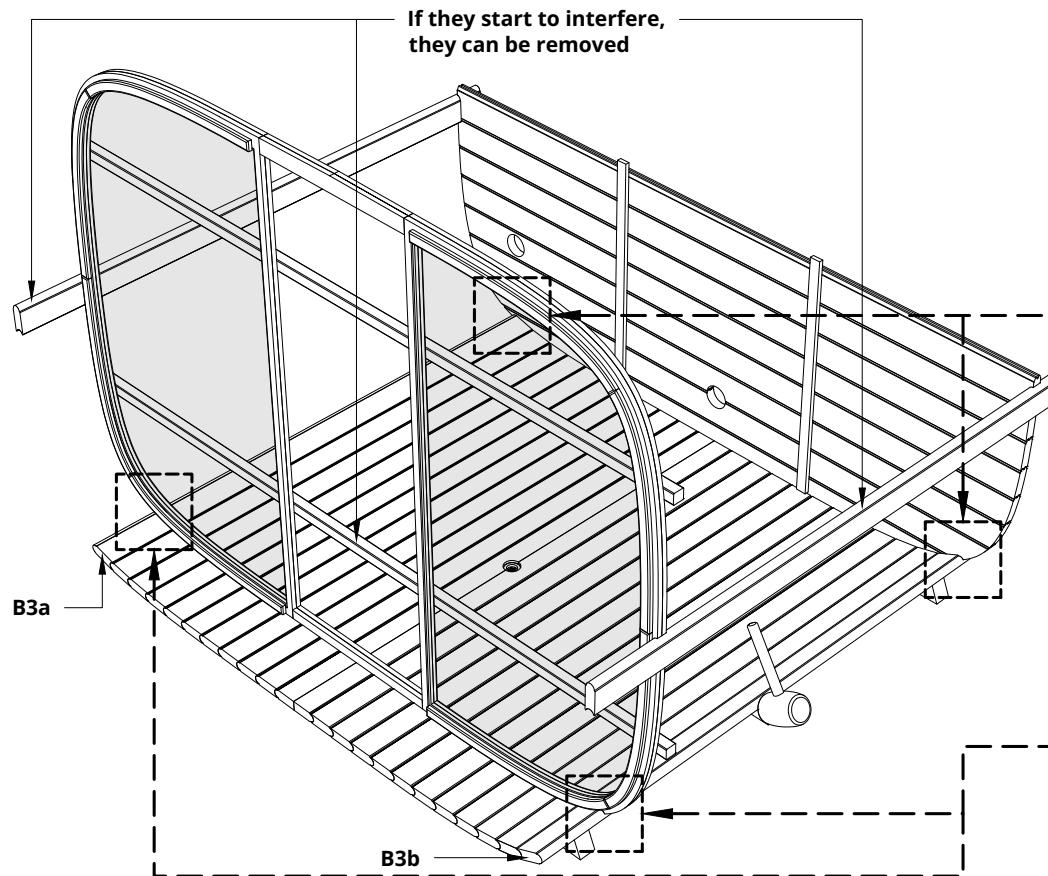
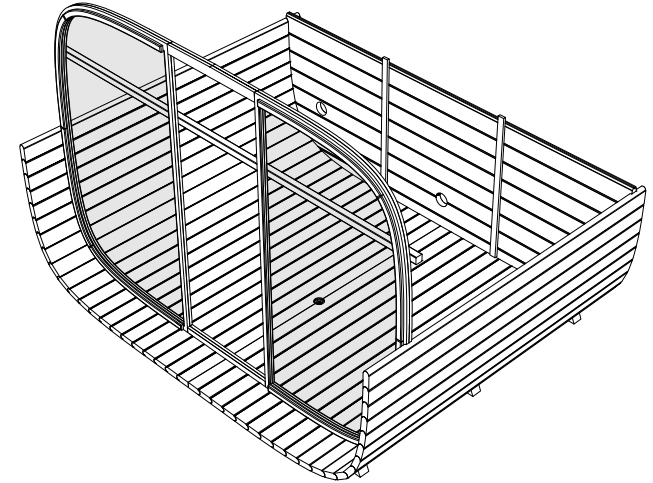

S7	Screws 4,5x60 for Spruce Screws 4,2x55 for Thermo	x2
		

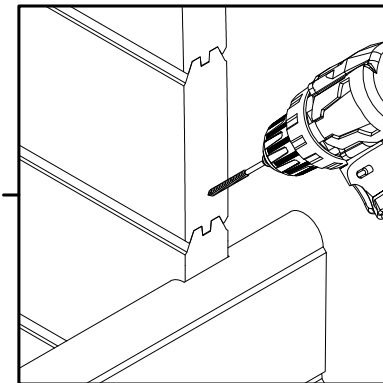
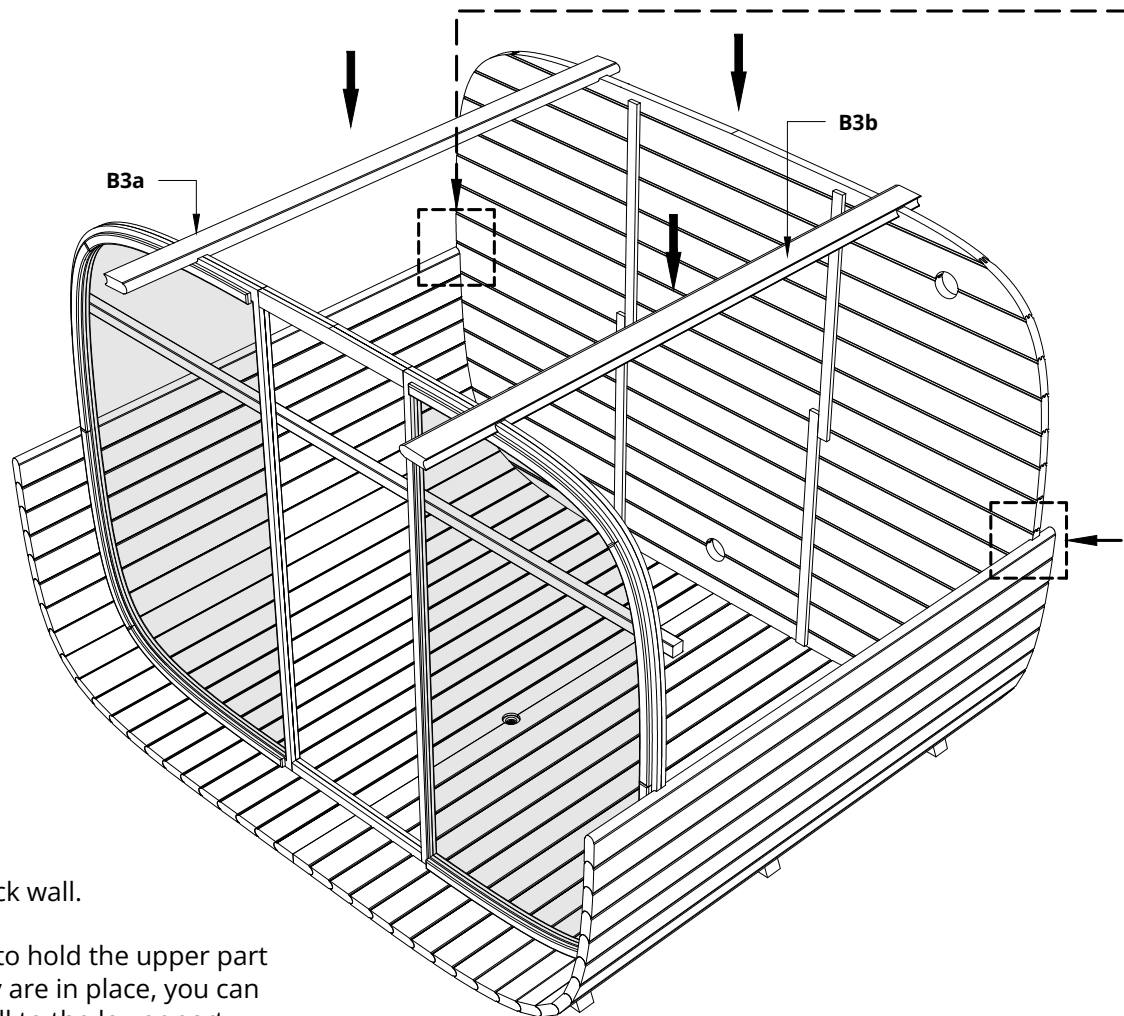

Now install the upper part of the back wall.

Install support boards B3a and B3b to hold the upper part of the back wall securely. When they are in place, you can screw the upper part of the back wall to the lower part.

Please countersink the screw head!

S5	Screws 4,5x60 for Spruce Screws 4,2x55 for Thermo	x84
		

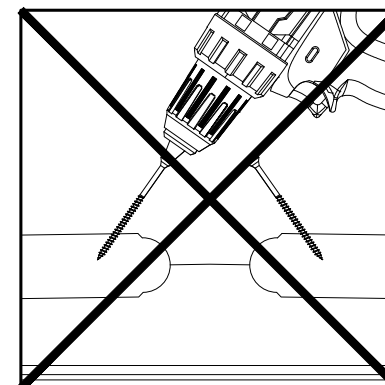
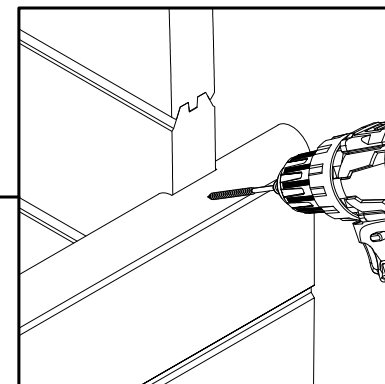
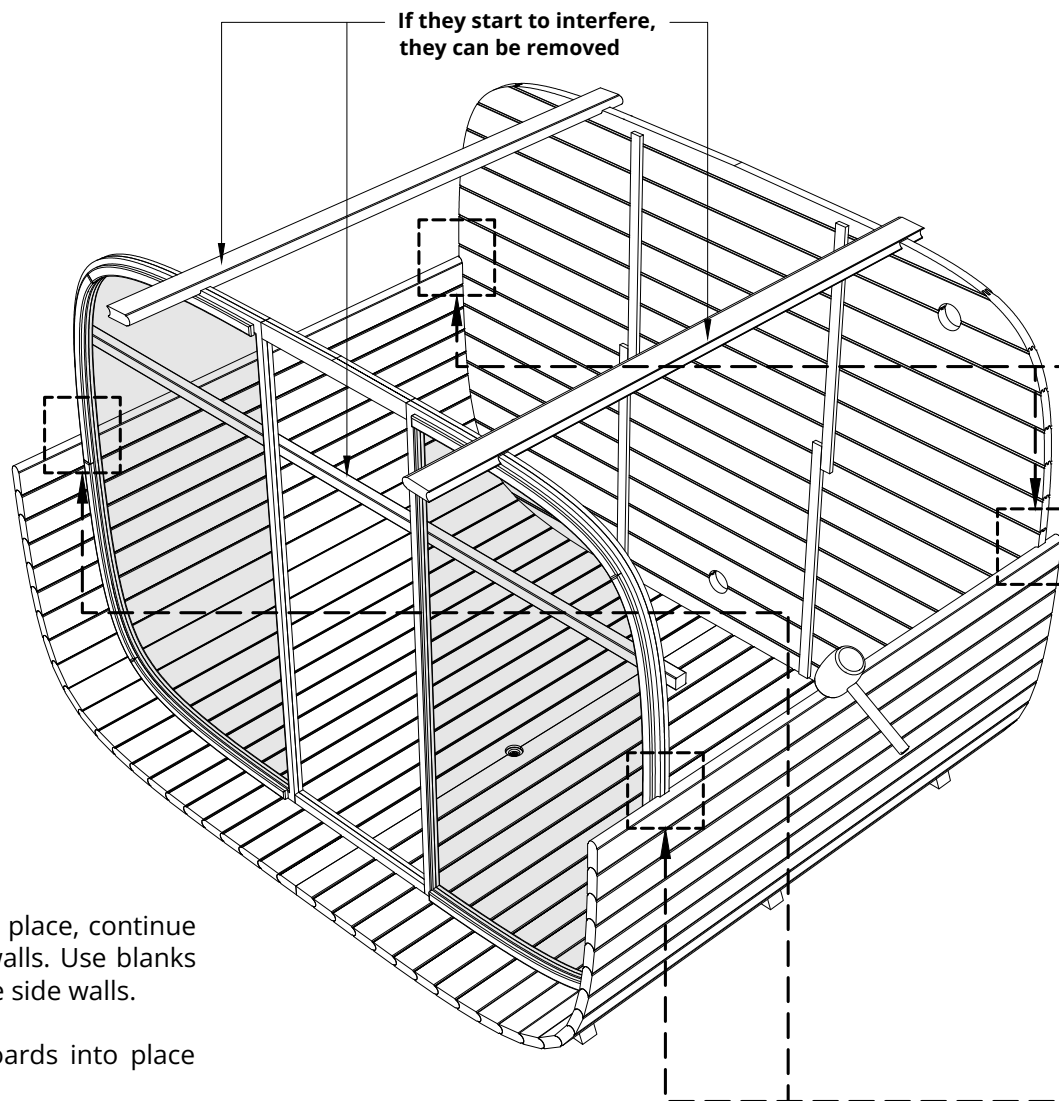

When the top of the back wall is in place, continue with the construction of the side walls. Use blanks B3a (left) and B3b (right) to build the side walls.

Use a rubber mallet to tap the boards into place and then fasten with screws.

Please countersink the screw head!
Please do not screw the screws in on the last whole blanks immediately.

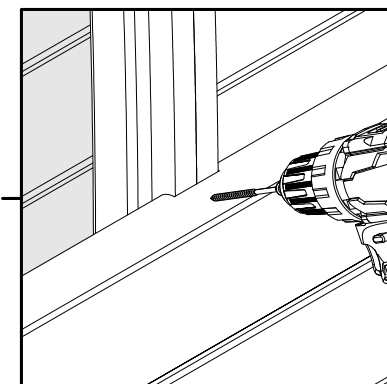

Please measure the gap front and back, the dimensions can be different.

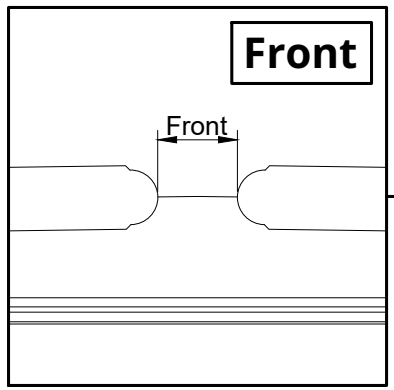
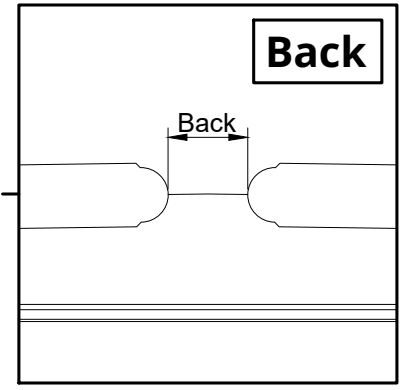
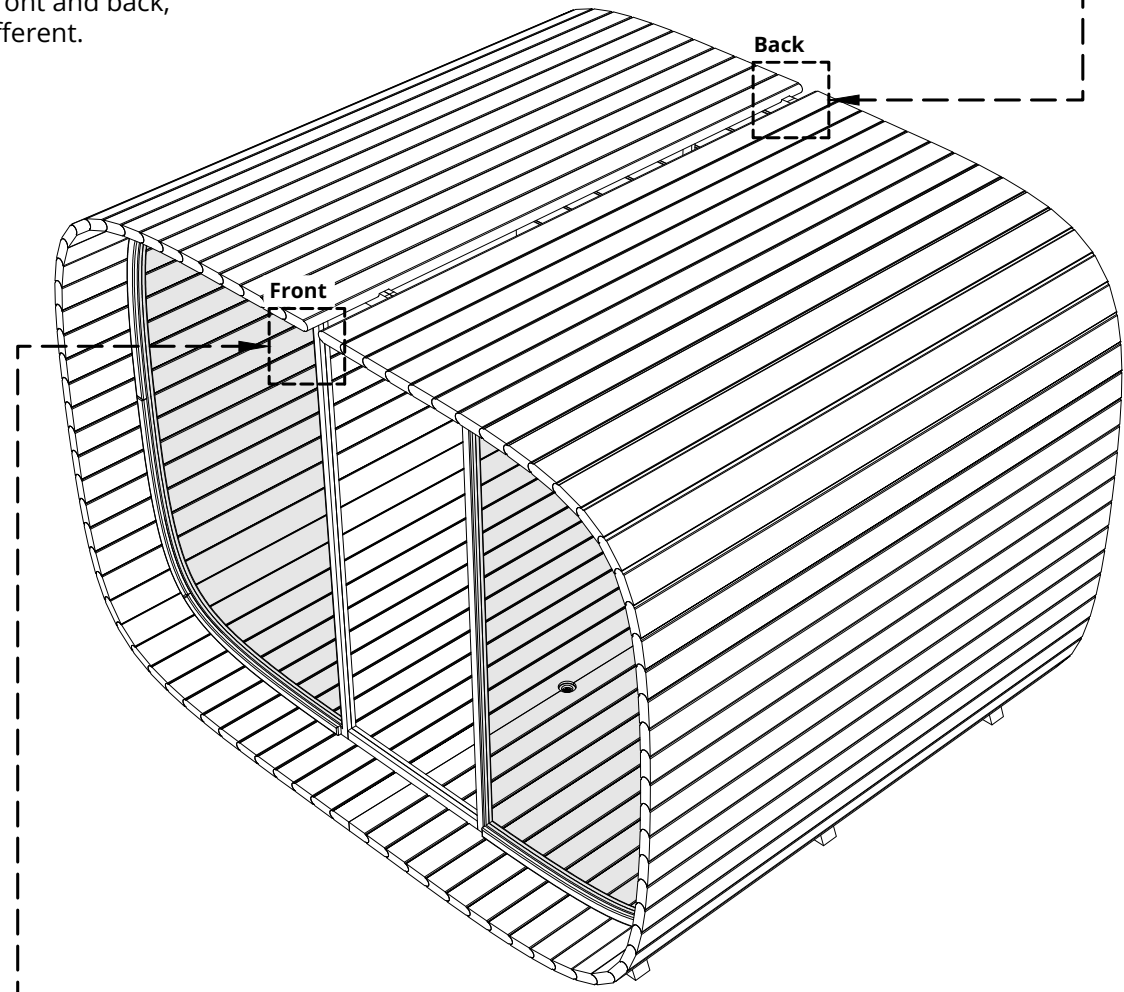

S2...7	Screws 3x40 ... 4,5x80	x7
		

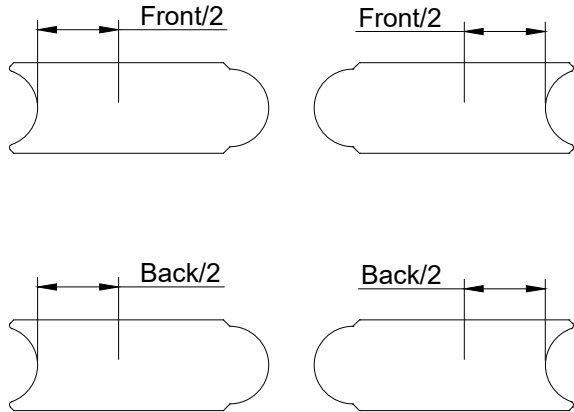

Divide the measurement by two and transfer the measurements to the last two planks. Connect the dimensions on the plank with a line and cut off these ends.

Glue the two freshly cut boards with wood glue and connect them with 7 pieces of 3x40 ... 4.5x80 screws (the length of the screws depends on the final width of the last two planks cut). Wipe off excess glue with a cloth and then use sandpaper to smooth out the gap.

Please countersink the screw head!

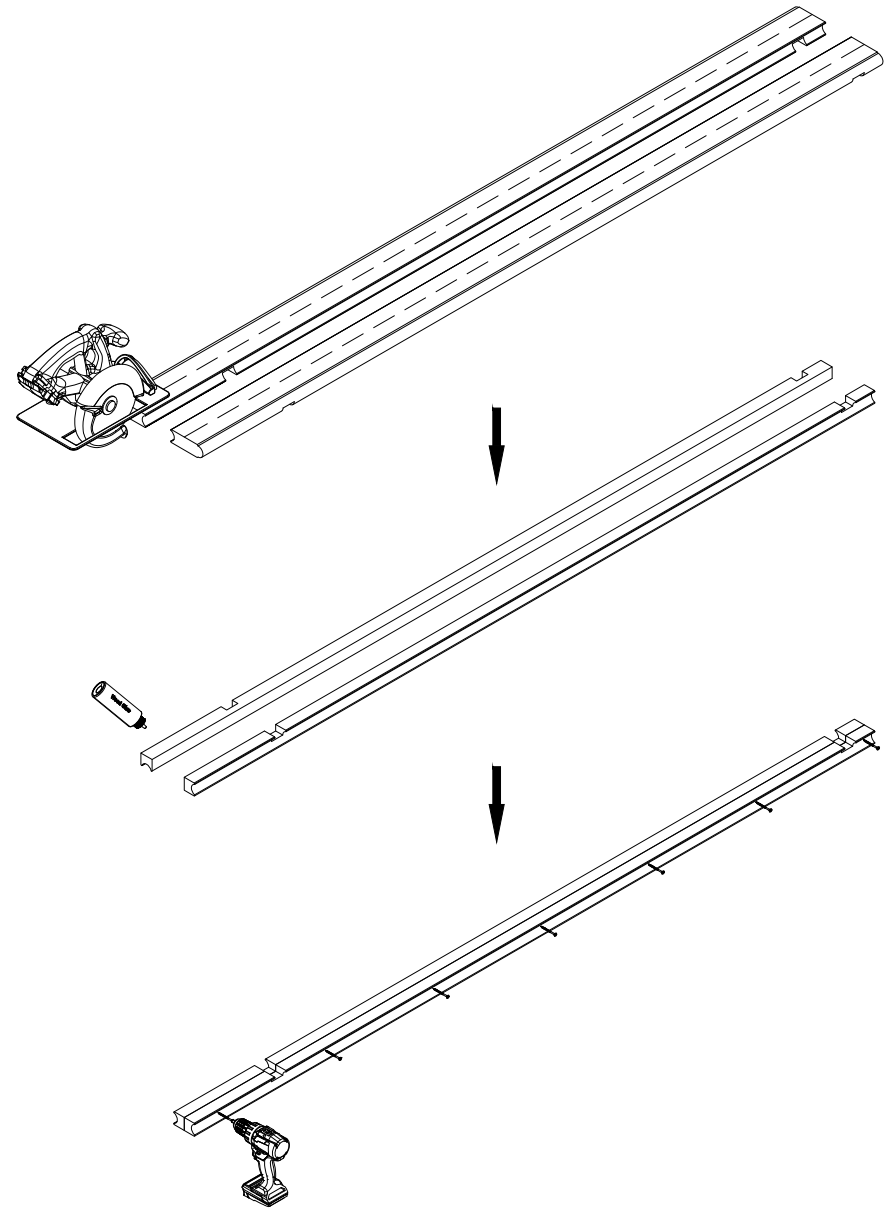

S5	Screws 4,5x60 for Spruce Screws 4,2x55 for Thermo	x6
		

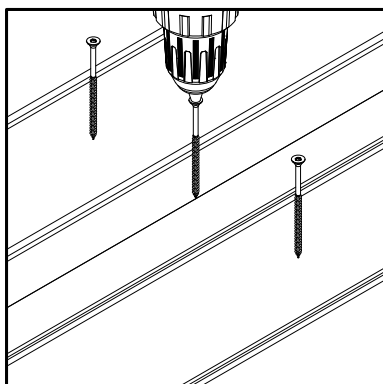
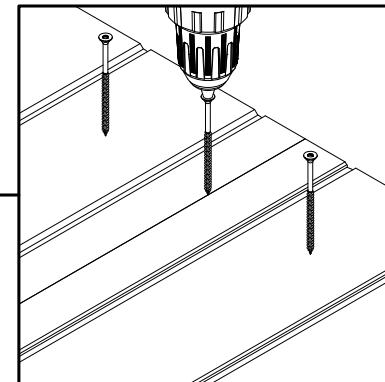
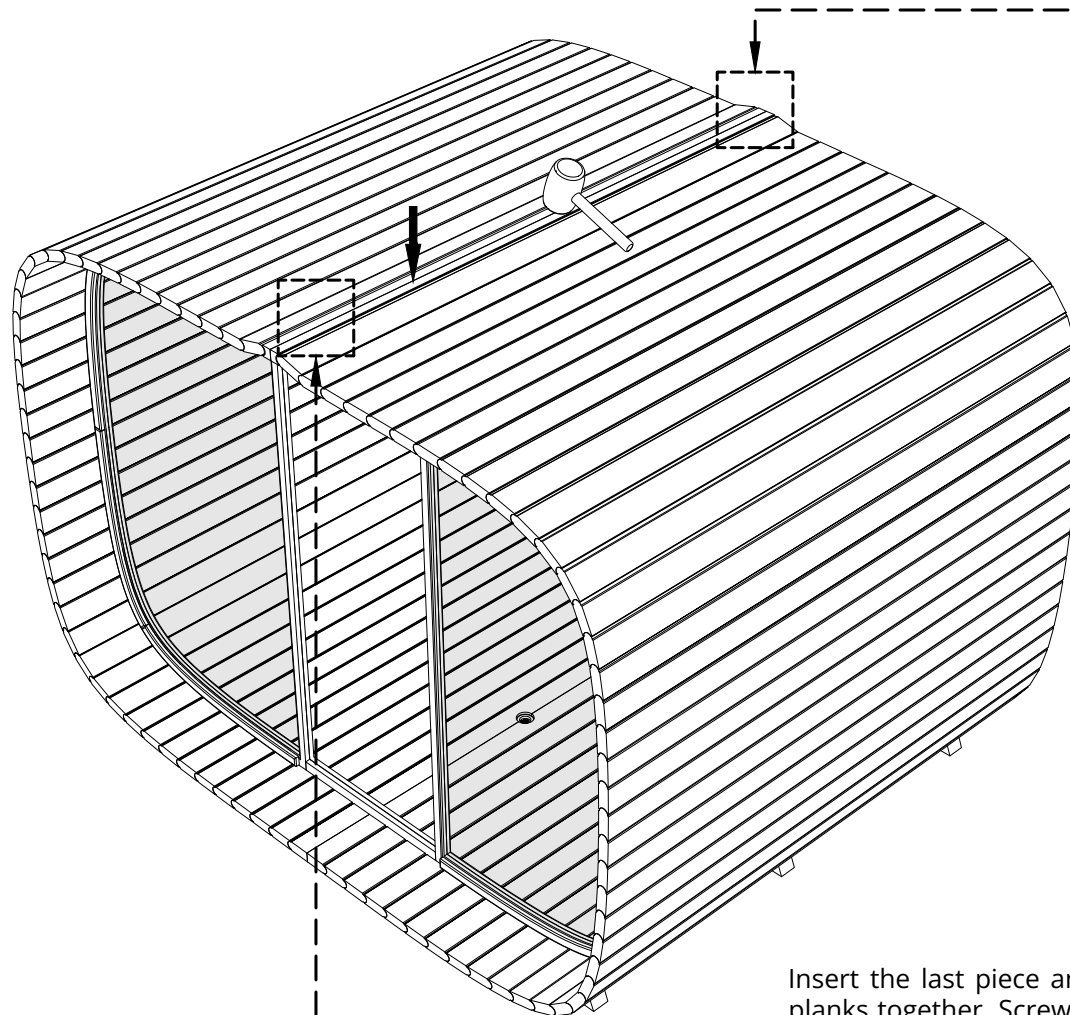

Insert the last piece and use a rubber mallet to tap the planks together. Screw the loose planks to the walls with screws.

Please countersink the screw head!

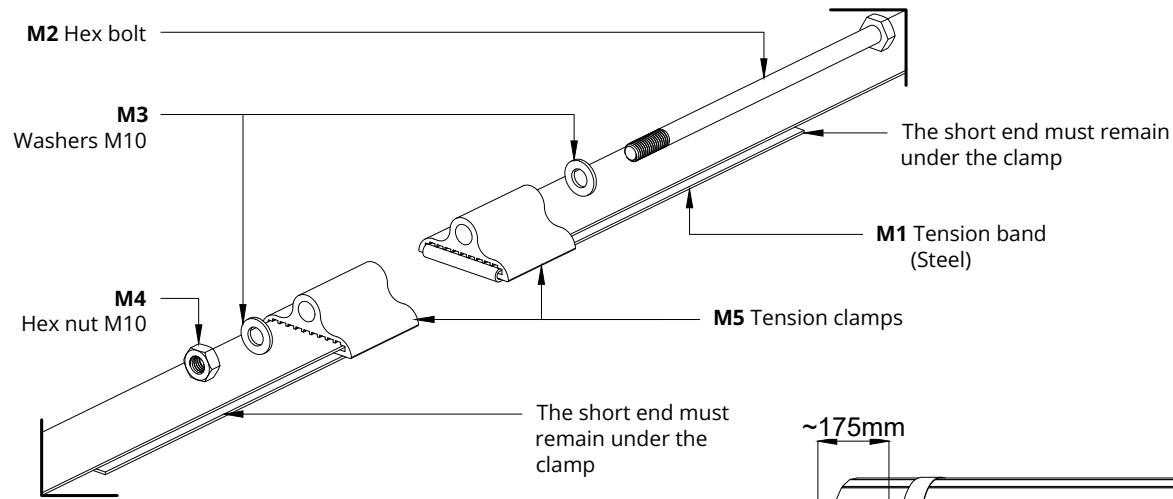

Place the tension bands M1 (Steel band) around the side walls and thread the bands into the eyelet as follows (see sketch above).

Hex nuts and bolts must be tightened as long as the planks are stationary in all directions.

The tension band and clamps must be placed as shown in the picture below.

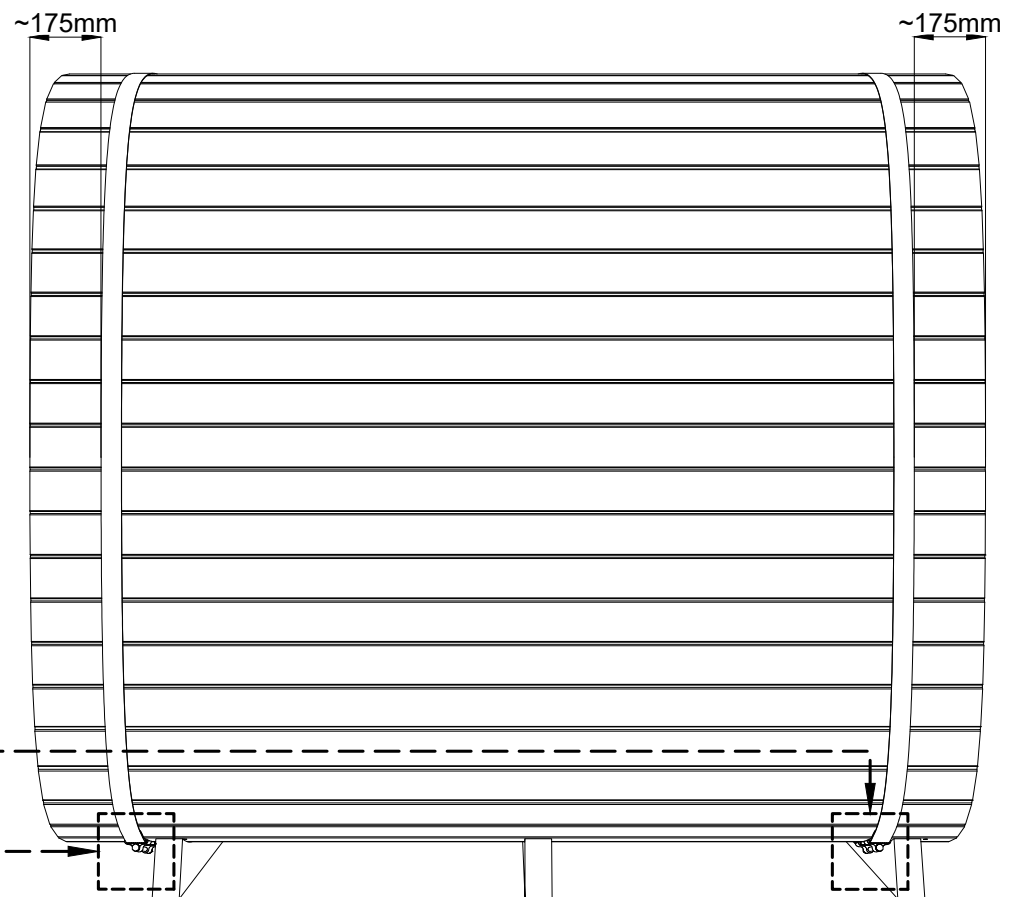
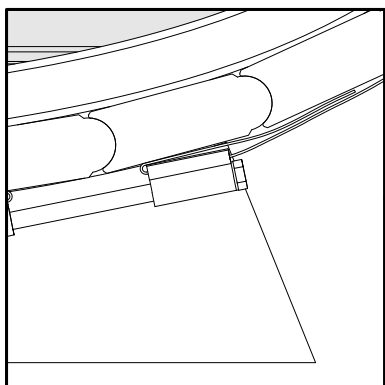

Remove the back wall connection strips

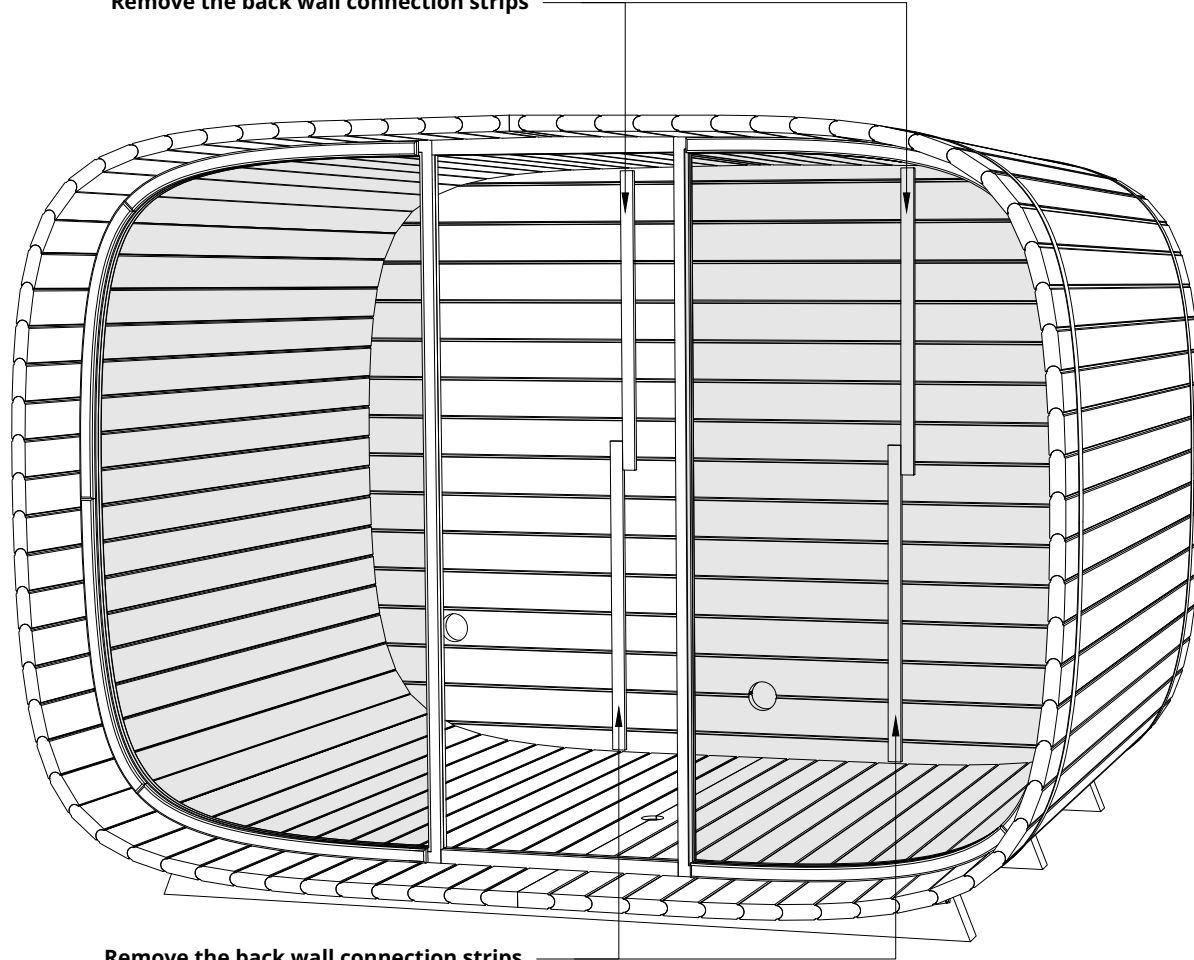

Remove the back wall connection strips

S1	Screws 3x30	x18
		

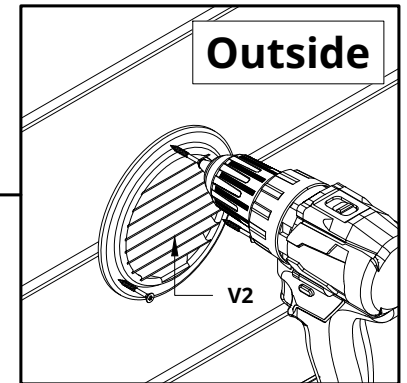
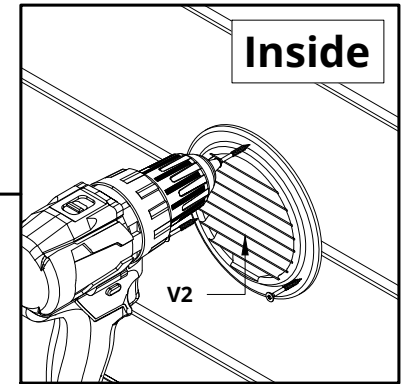
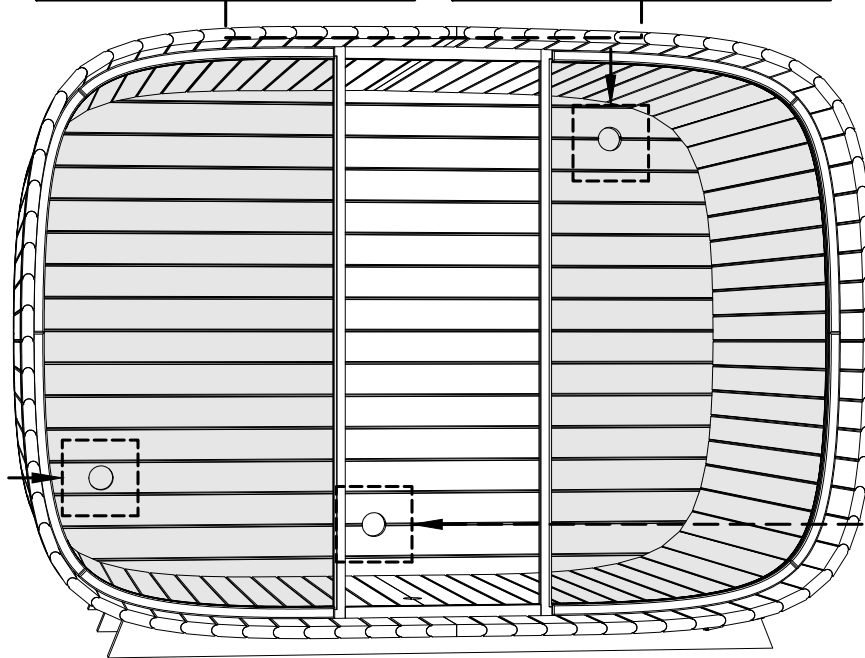
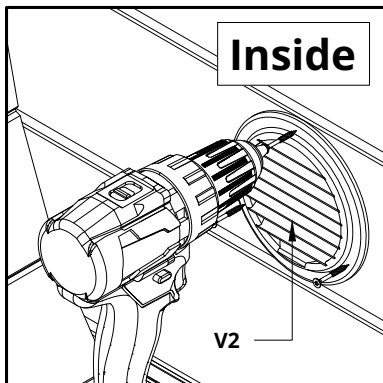
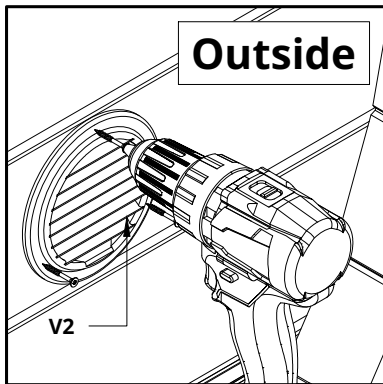
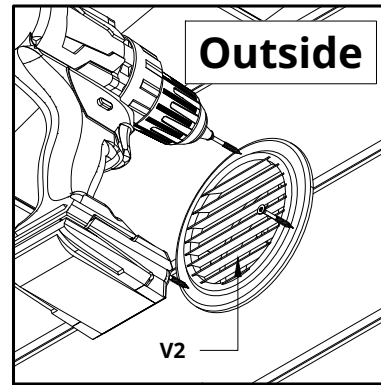
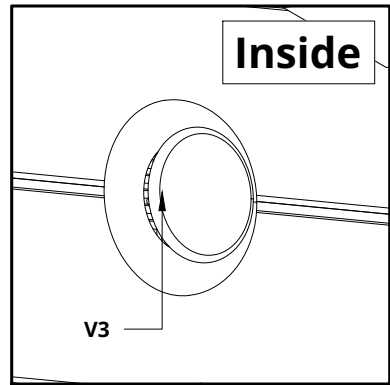

The inner and outer ventilation grilles V2 and adjustable cover V3 are screwed with 3 screws.

S6.2	Screws 4,2x75	x14
S3.2	Screws 4,5x50	x14
		

NB! use a level

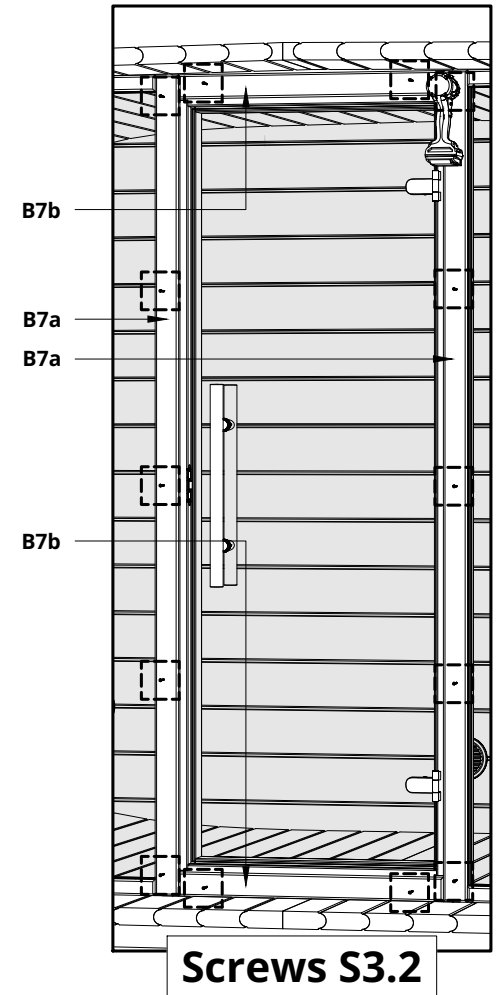
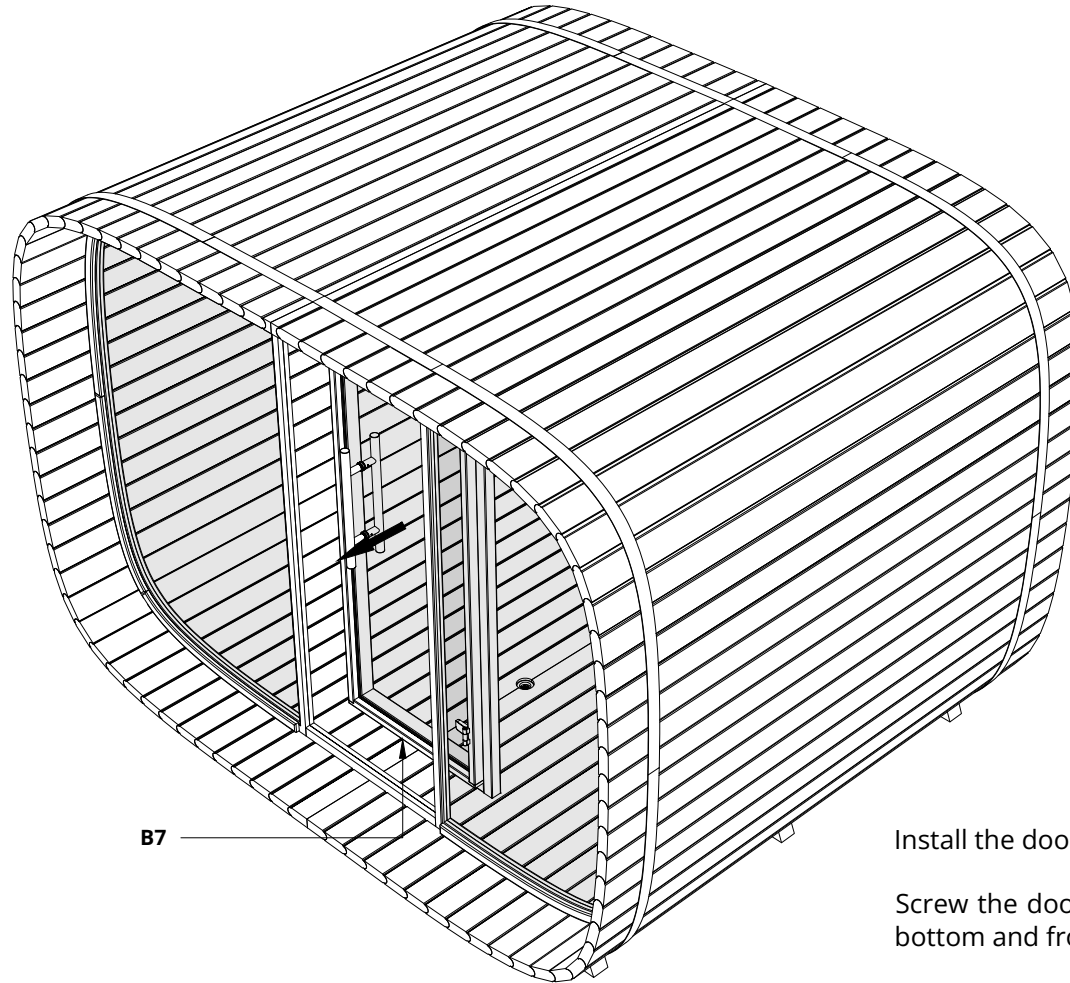
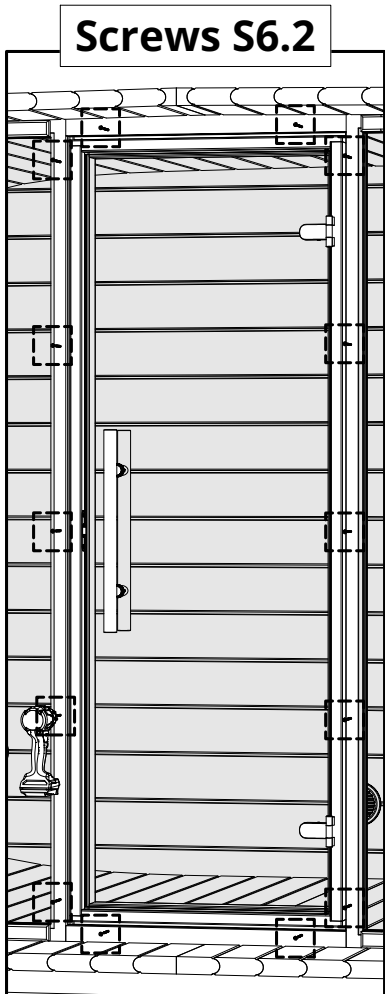
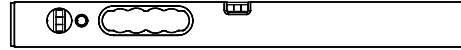

Install the doors from inside (shown in the picture).

Screw the door from the sides with 5 screws from the bottom and from the top with 2 screws.

If the door is in place, install the door moldings, top with 2 screws and bottom with 2 screws and the sides with 5 screws.

Please countersink the screw head!

R5	Nail 2,5x25
	

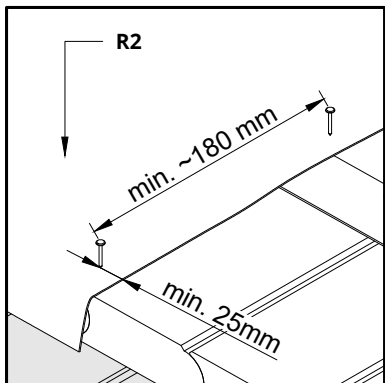
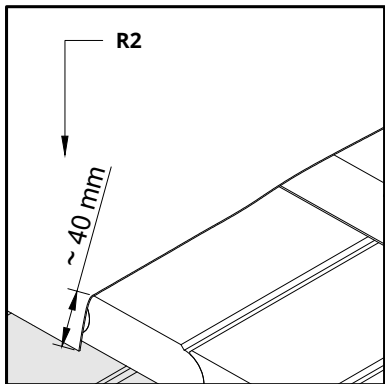
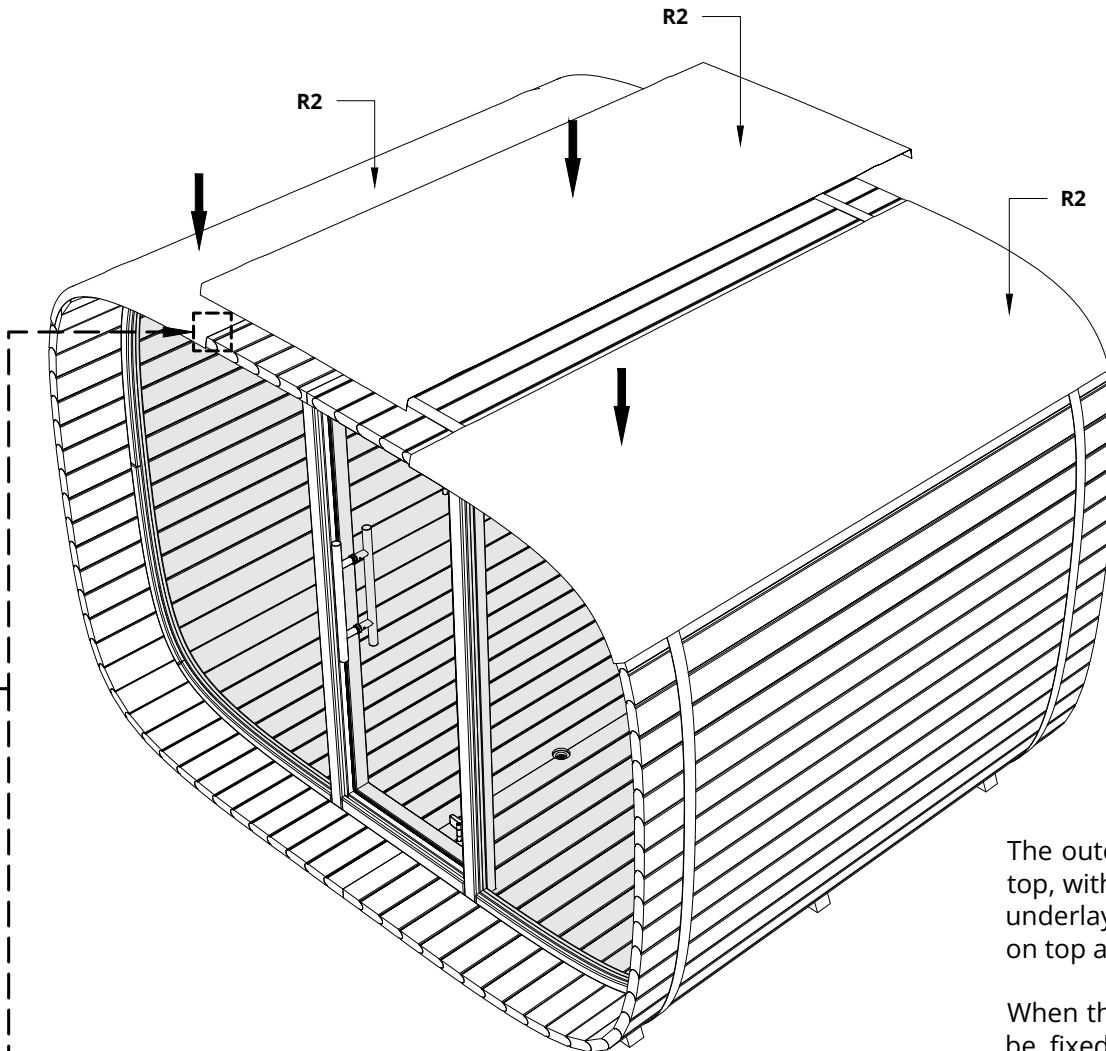
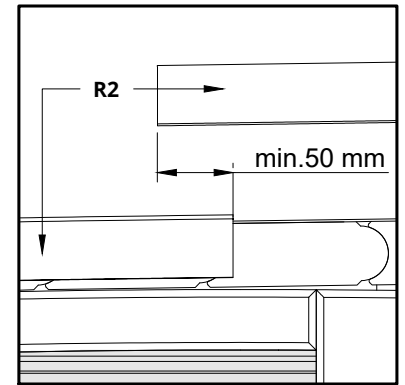

Install first outer underlayment so that the middle underlay overlaps the outer ones by at least 50 mm to cover the nail heads.

The underlay must extend over the front end and back end at least by 40 mm.

The outer underlays are fixed with nails from the top, with a gap of about 180 mm. When the outer underlays are in place, put the middle underlay on top and use a heat source to make it stick.

When the underlays are in place, their ends must be fixed. They must be bent before fixing with nails.

Use a heat source when you bend them, otherwise they may break or leave cracks.

R5	Nail 2,5x25
	

The base sheet of the first row must be installed first.

Sheets are self-adhesive, for better adhesion use a heat source.

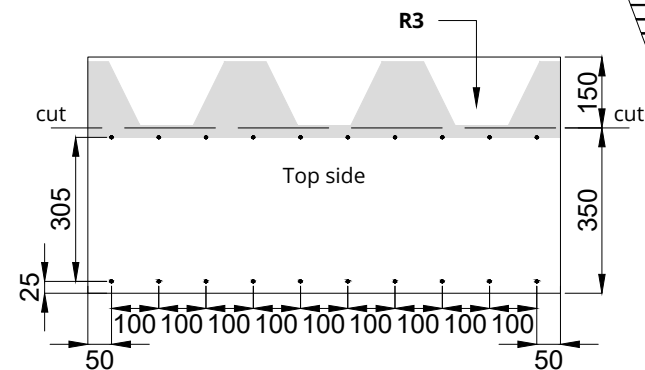
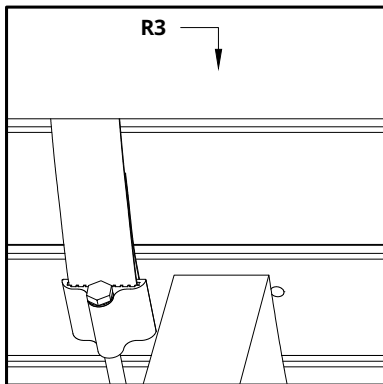
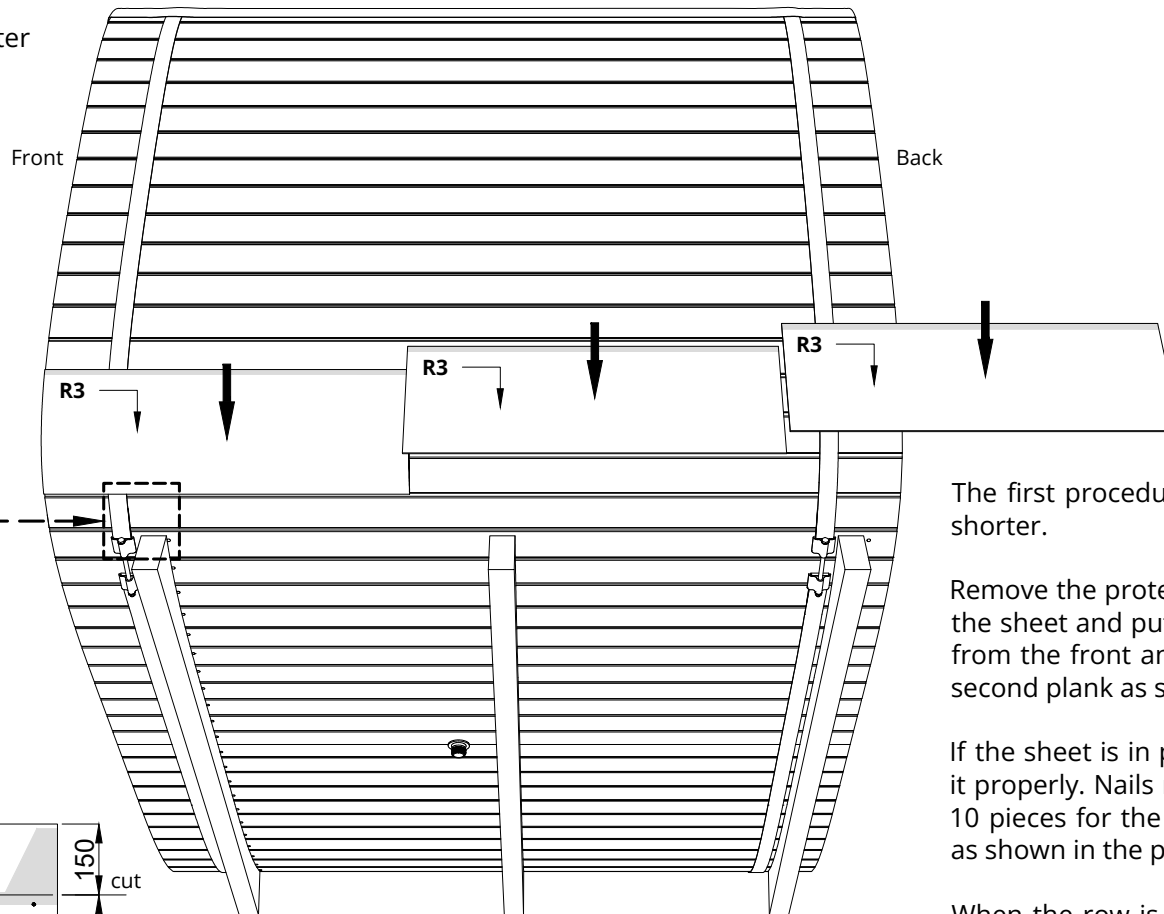
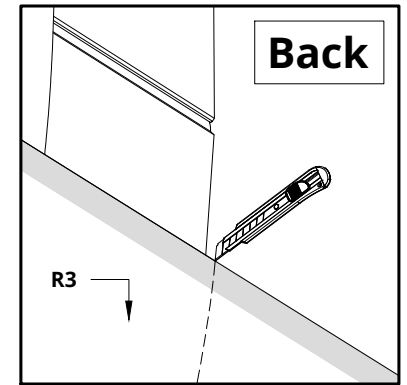

The first procedure is to cut the sheet 150 mm shorter.

Remove the protective films from the bottom of the sheet and put it in place by starting the row from the front and bottom of the sauna on the second plank as shown in the pictures.

If the sheet is in place, nails must be used to fix it properly. Nails must be placed every 100 mm, 10 pieces for the whole sheet below and above as shown in the picture.

When the row is finished and extends over the edge, it must be cut off and the leftovers can be used to complete the row on the other side.

Repeat these steps on the other side as well!

R5	Nail 2,5x25
	

The first sheet of the first row starts from the bottom and center of the side wall of the sauna.

Sheets are self-adhesive, for better adhesion use a heat source.

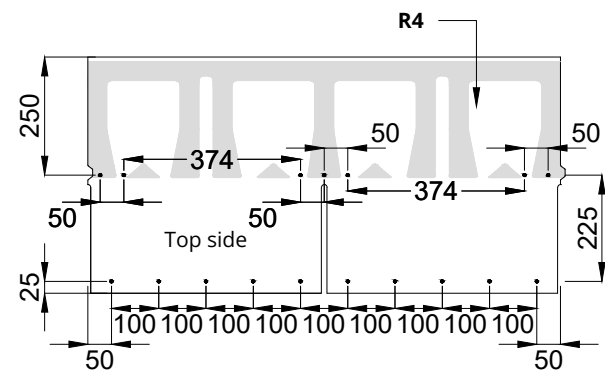
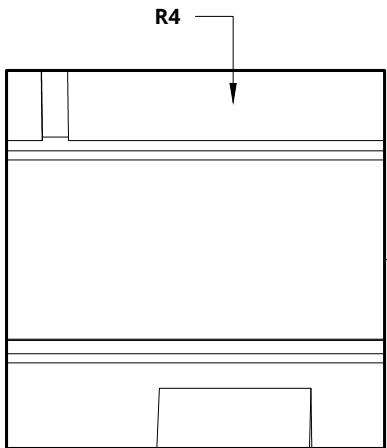
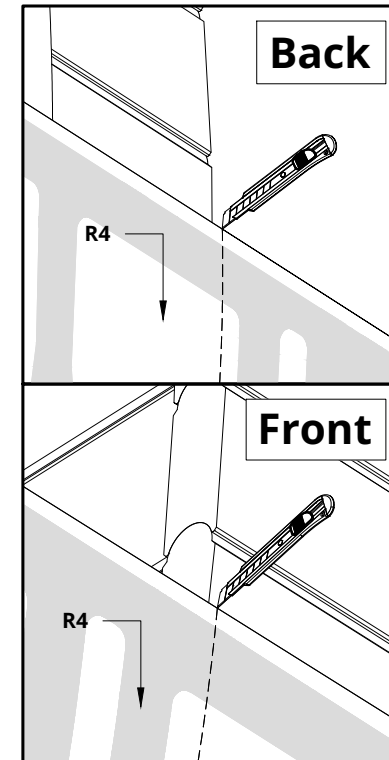
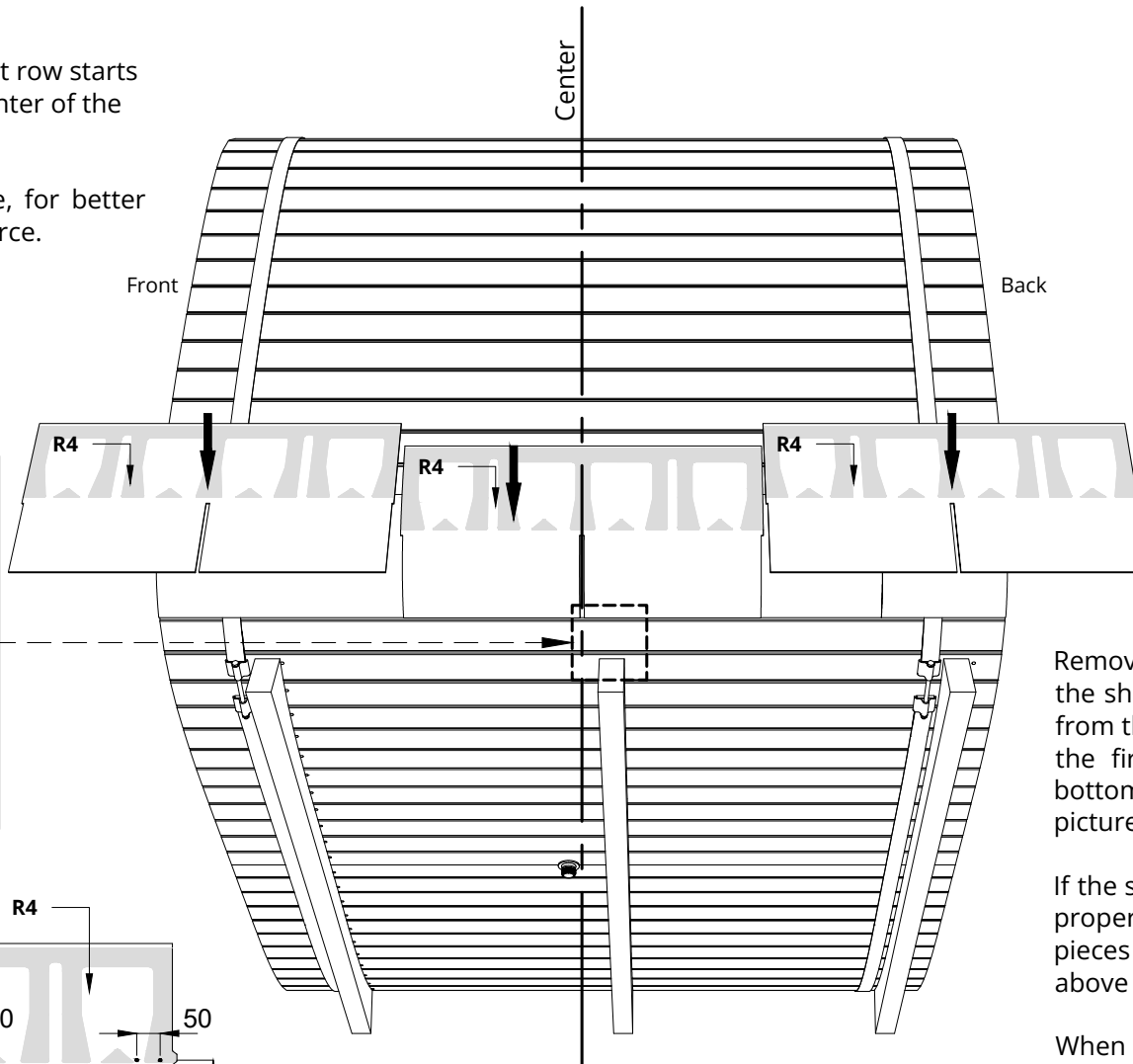

**Repeat these steps on the other side as well!
(THE LOWER FASTENING NAILS ARE ONLY IN
THE FIRST ROW)**

Remove the protective film from the bottom of the sheet and put it in place by starting the row from the bottom and center. The bottom edge of the first row sheet must be in line with the bottom edge of the base sheet shown in the pictures.

If the sheet is in place, nails must be used to fix it properly. Nails must be placed every 100 mm, 10 pieces for the whole sheet below and 7 pieces above as shown in the picture.

When the row is finished and extends over the edge, the excess must be cut off and the left-overs can be used in the following rows.

See page 22 for a recommendation on row arrangement.

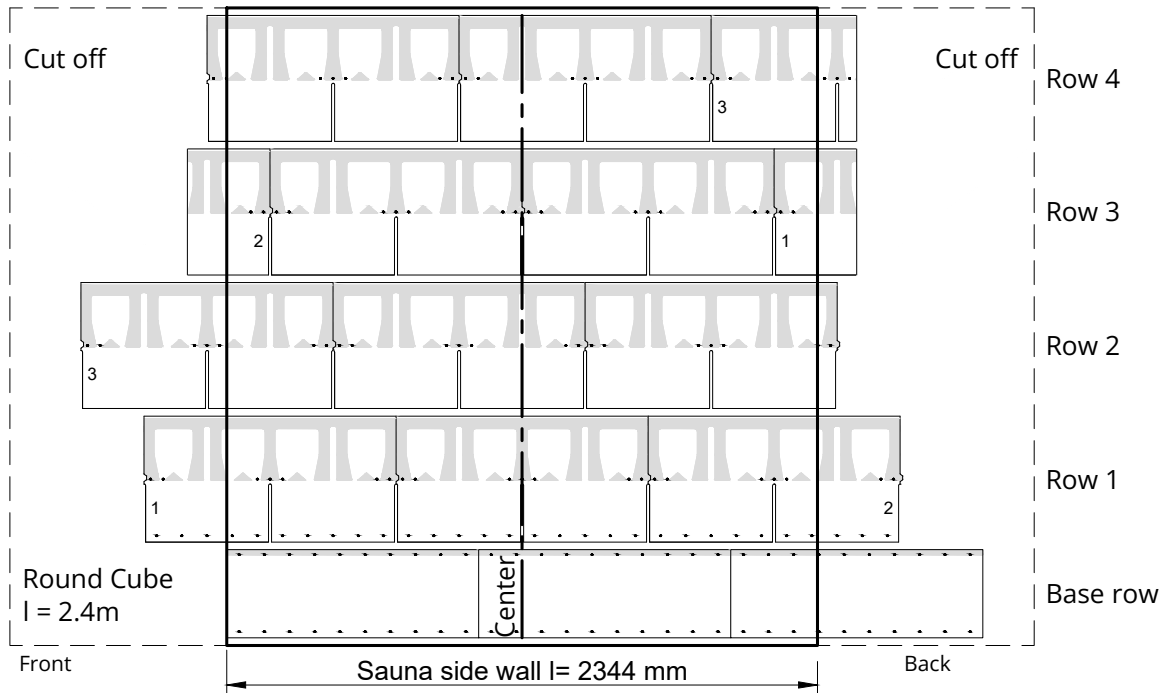

Bitumen roof sheet row arrangement for Round Cube 2.4 and 2.6

The base row is installed first, then the first row, etc. up in the middle of the sauna. The sheets that remain over the edge of the sauna wall are cut off and, if possible, used for other rows.

The base row starts at the front end of the sauna, row 1 always starts in the middle, the other rows are offset from the middle.

For row 1, use nails to fix the lower end, and for row 2, use the included bitumen silicone. Subsequent rows from the second row do not need fix from lower end.

The layout pattern repeats every 4 rows.

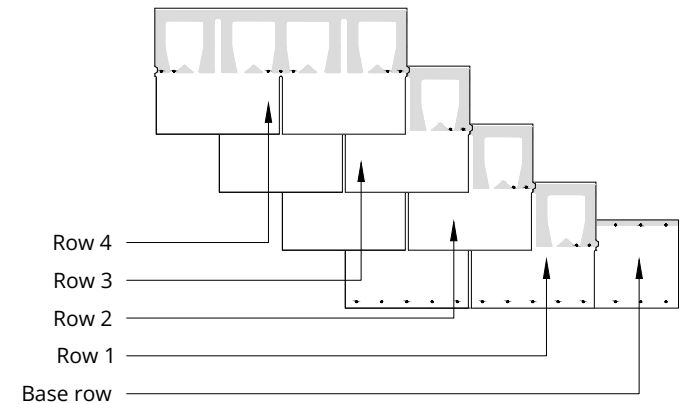
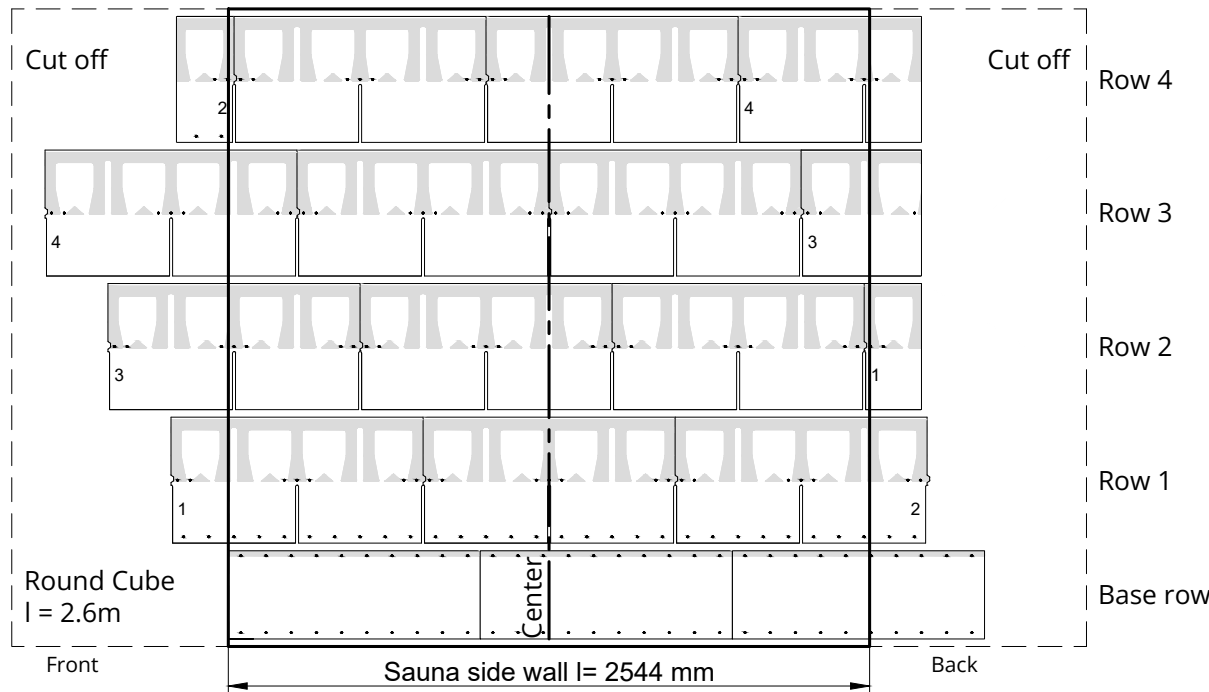

R5	Nail 2,5x25
	

The roof ridge must be placed in the middle, starting from the back end of the sauna or from the front end.

Sheets are self-adhesive, for better adhesion use a heat source.

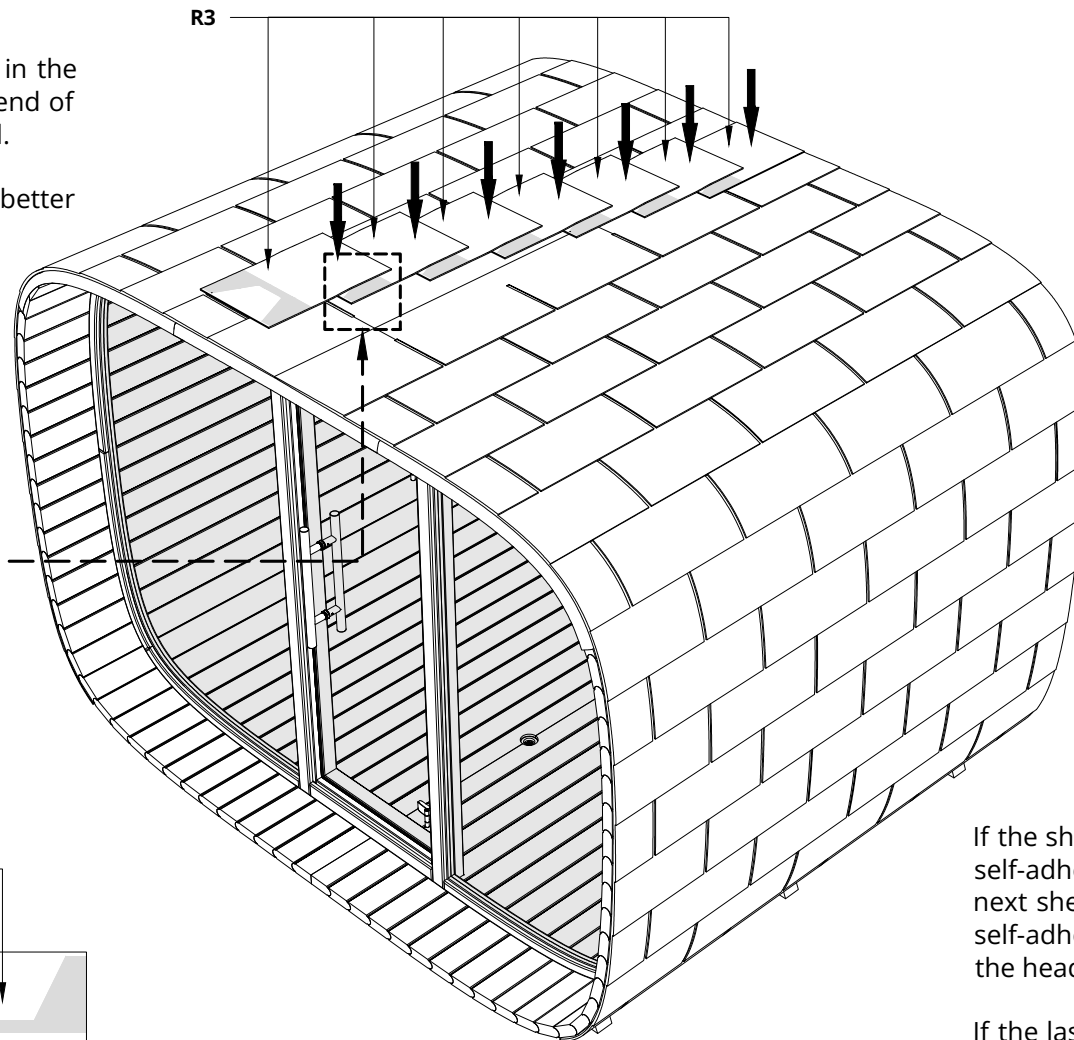
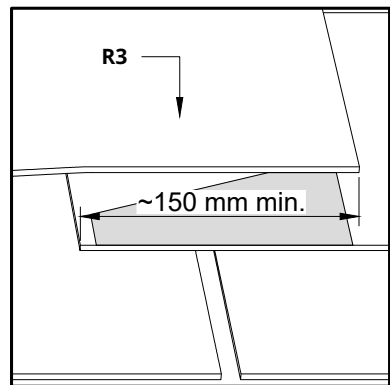
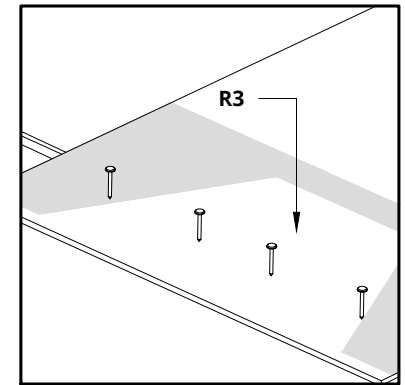

If the sheet is in place, fasten it with 4 nails on the self-adhesive spot as shown in the picture. The next sheet must be placed so that it overlaps the self-adhesive spot of the first sheet and covers the head of the nail min. length 150 mm.

If the last sheet extends over the edge, it must be cut off, and if the self-adhesive part remains visible, it must be covered with a suitable piece of excess, use bitumen silicone for fixing.

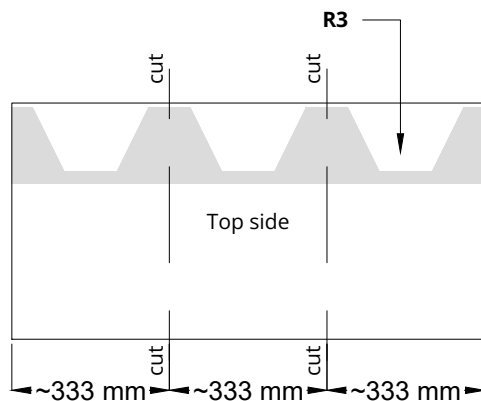

The first procedure is to cut the sheet into three pieces.

Remove the protective film from the sheet and put it in place by starting the ridge row from back end of the sauna or from the front end.

S6.1	Screws 4,5x70 (black coated)	x60
		

NB! use a level

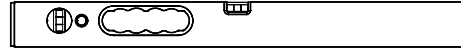

Installation of cover boards at the front end and at the back end of the sauna.

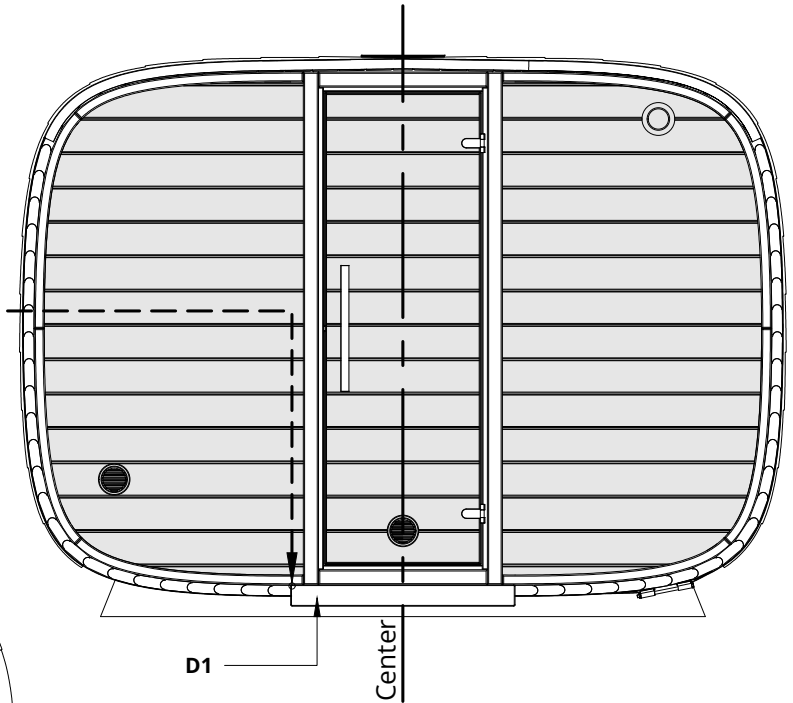
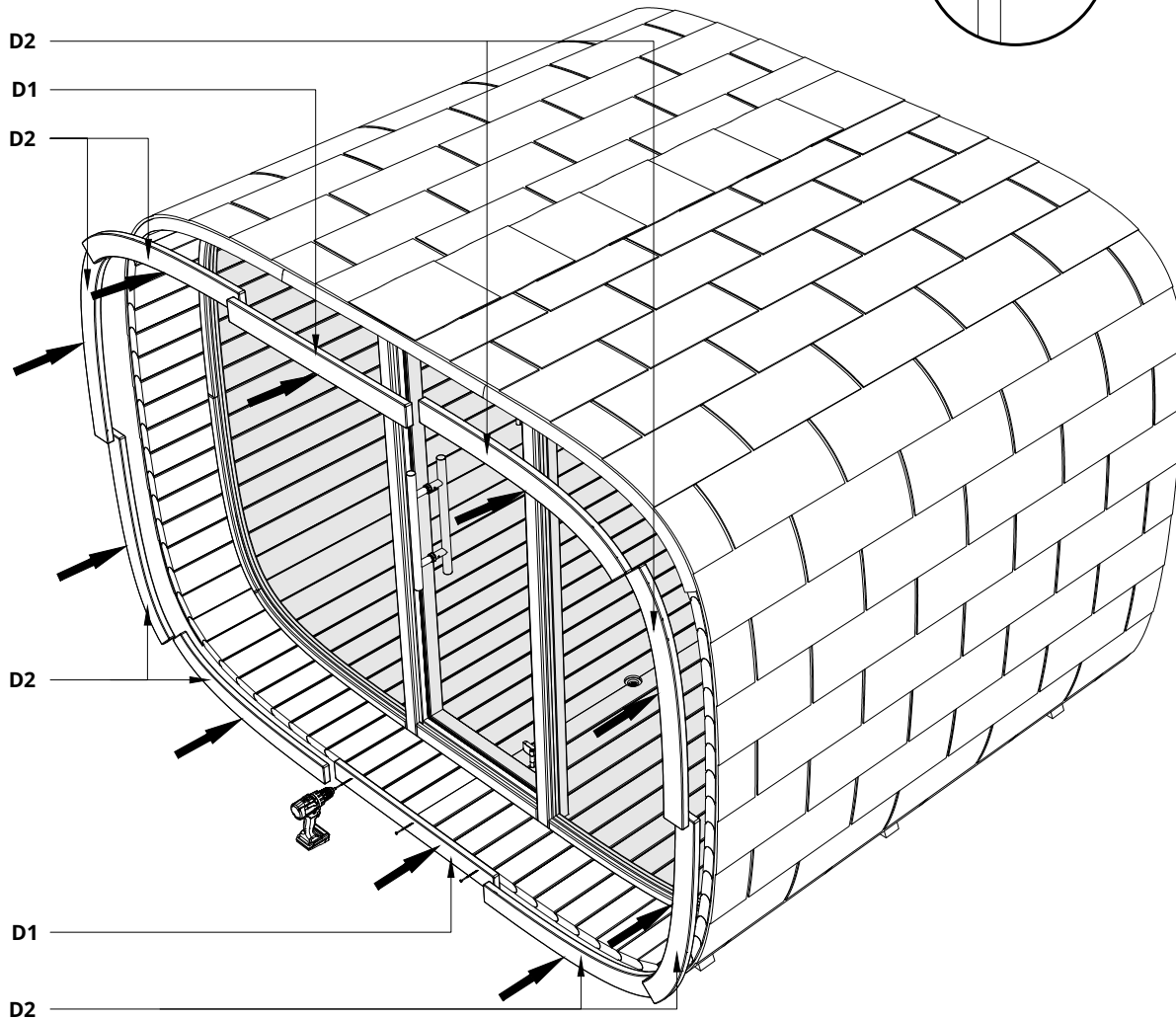
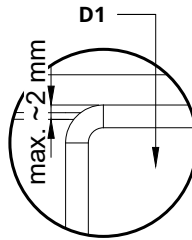

The installation of the cover boards is started from the bottom and the first cover board must be in the center at the front end and at the back end of the sauna.

The upper edge of the first cover board must be at the same height as the floor. It can also be a little higher than the floor level, but not more than 2 mm.

Glue must be added to the lower 3 cover boards before screwing. Each cover board is screwed with 3 screws.

If the front end of the sauna is done, the back end of the sauna must be done in the same way.

Please countersink the screw head!

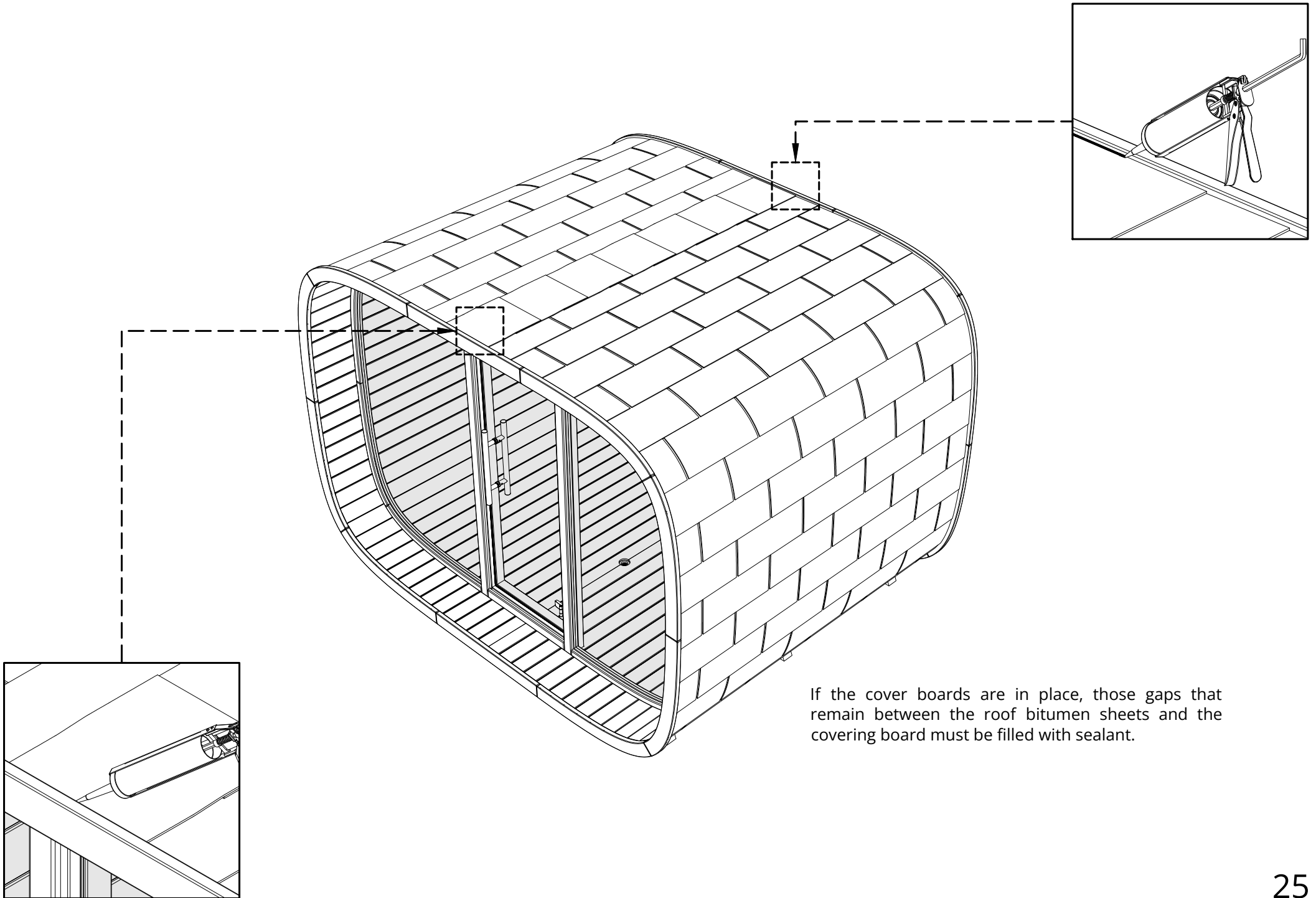

If the cover boards are in place, those gaps that remain between the roof bitumen sheets and the covering board must be filled with sealant.

S7	Screws 4,5x80 for Spruce Screws 4,2x75 for Thermo	x16
		

NB! use a level

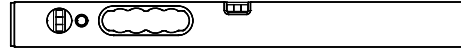

Notice!

Drill 4mm hole in the K.. square woods before screwing.

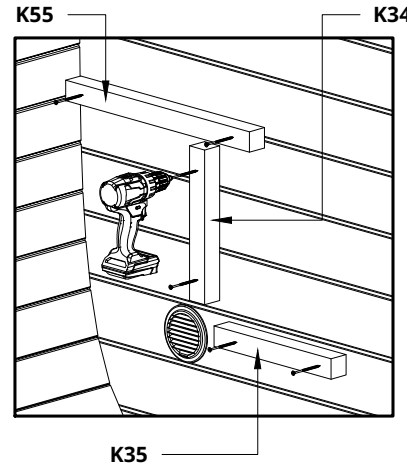
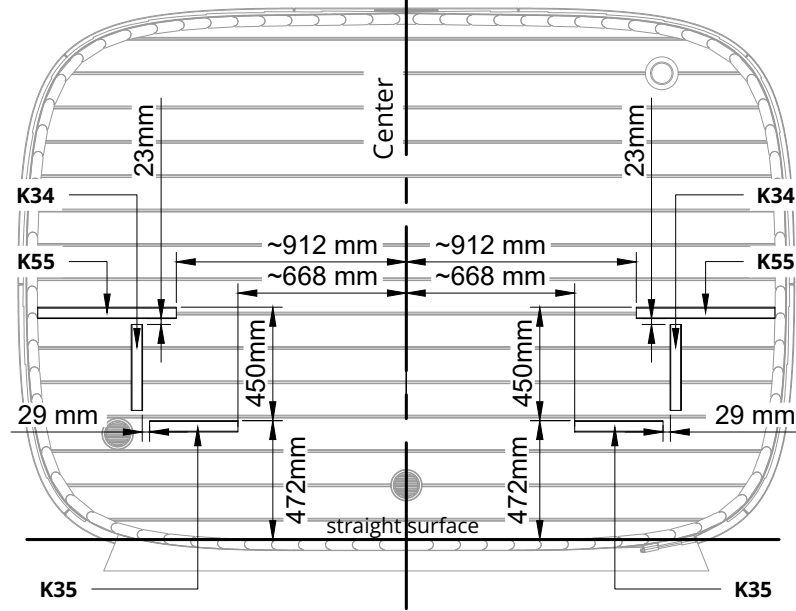
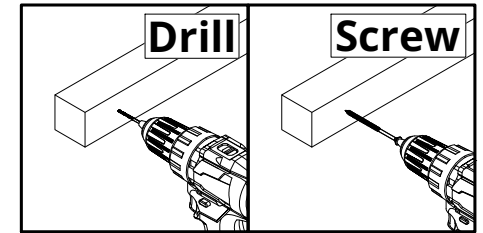

Height measurements are measured from a straight surface.

Please countersink the screw head!

First measure and install wall mount K35. Measure the height from straight surface and the distance from center. The upper edge height from the straight surface of K35 is shown in the picture.

Next measure and install K55. Measure the upper edge of the wall mount K55 from the wall mount K35 and the distance from center.

Next measure and install bench skirt wall mount K34. Measure the upper edge of the wall mount K34 and the outer edge depth distance from the wall mount K35. The K34 wall mount should be perpendicular to the K55 wall mount.

Now measure and install K30 on both sides. Measure the height straight surface and distance from the back wall.

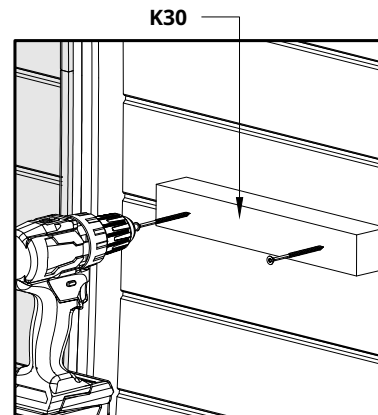

Before installing square wood K30, K34, K35 and K55, drill holes for screws. Add glue and then screw it to the wall and wipe off the excess glue.

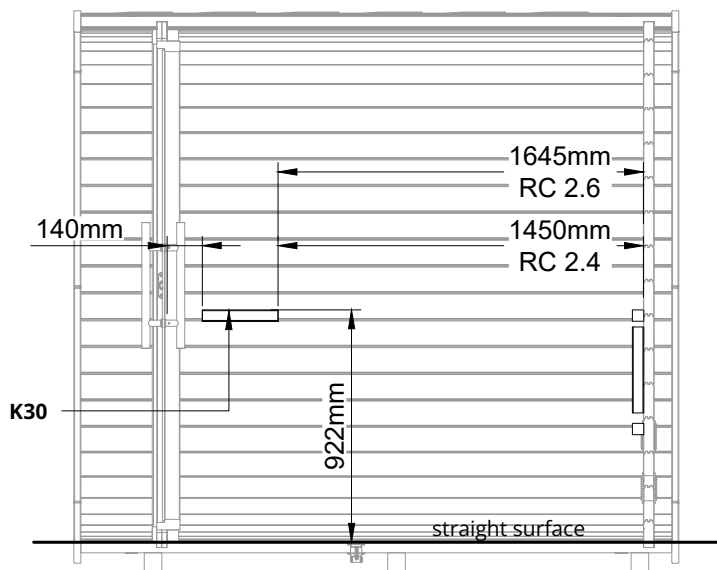

S5	Screws 4,5x60 for Spruce Screws 4,2x55 for Thermo	x4
S7	Screws 4,5x80 for Spruce Screws 4,2x75 for Thermo	x12
		

NB! use a level

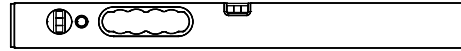

Notice!

Drill 4mm hole in the K10 square wood before screwing.

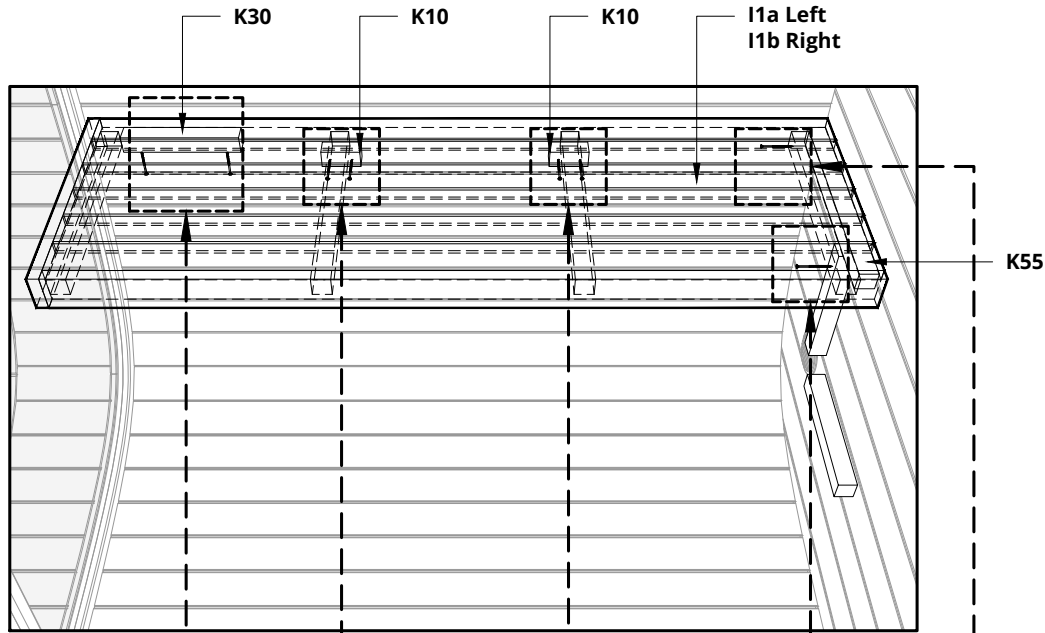
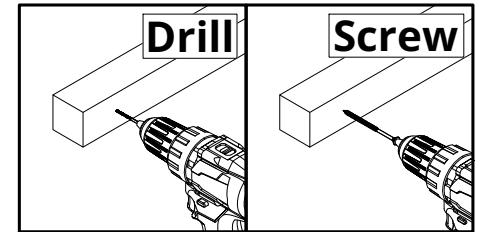

Install and fix the I1a upper bench to the wall mounts K55 with two S7 screws and K30 with two S5 screws.

Install some aids to keep the bench level.

Once the upper bench is attached, K10 must be installed next. K10 must be installed at the lower edge of the square wood attached under the bench and fixed to the side wall with two S7 screws, the locations are shown in the pictures.

Before installing square wood K10, drill holes for screws. Add glue and then screw it to the wall and wipe off the excess glue.

Repeat these steps on the other side as well!

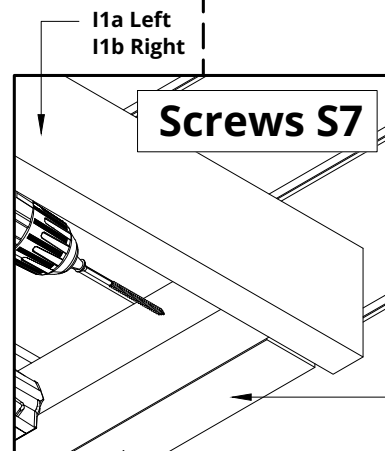
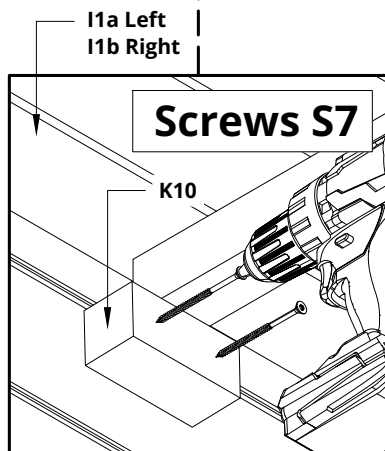
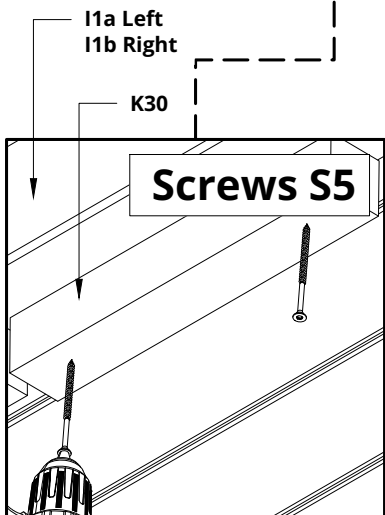

S5	Screws 4,5x60 for Spruce Screws 4,2x55 for Thermo	x8
		

NB! use a level

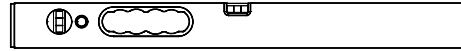

Notice!

Drill 4mm hole in the K.. square woods before screwing.

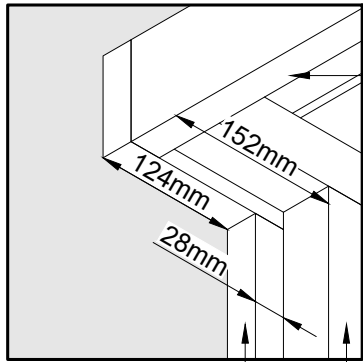
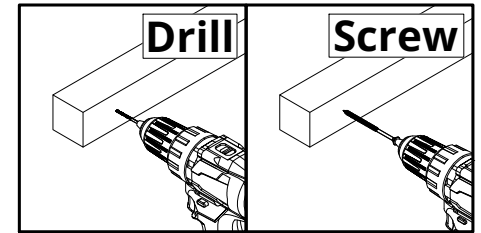

The measurement must be started from the lower edge of the square wood attached under the bench for square wood legs.

The square wood and cover board are longer, they must be cut to the correct size.

Please countersink the screw head!

Before installation, mark the distance of the square wood K90 from the outer edge of the bench. Measure from bench I1a down to the floor. Cut the K90 to size. If it is cut correctly, make sure that square wood K90 stays perpendicular to the bench when attaching it.

Before installing the cover board D3, mark the distance from the outer edge of the bench.

Measure from the marked point down to the floor. Cut the D3 cover board to size. If it is cut to size, fasten with two S5 screws.

Make sure that cover board D3 stays perpendicular to the bench and in parallel with K90 when attaching it to K90.

Repeat these steps on the other side as well!

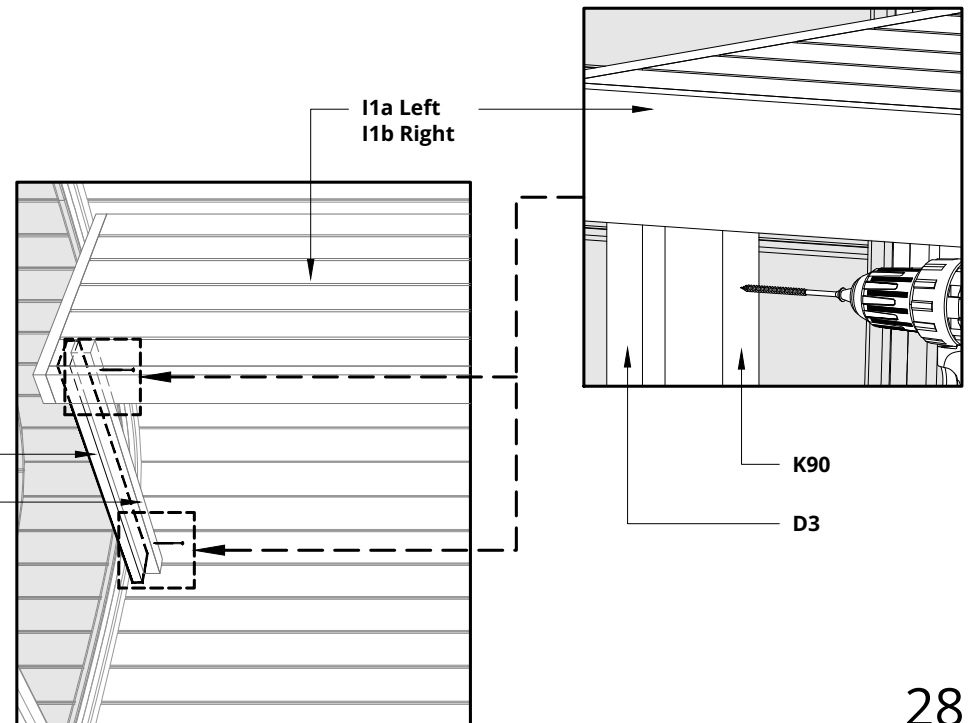
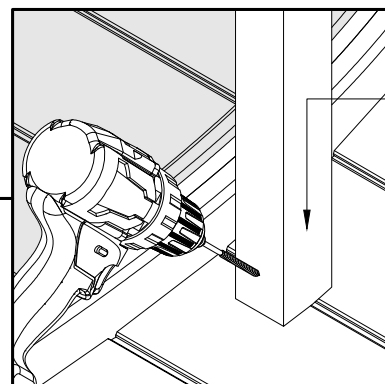
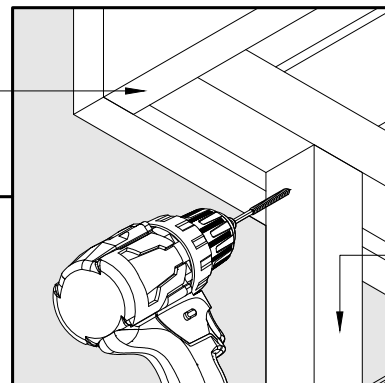
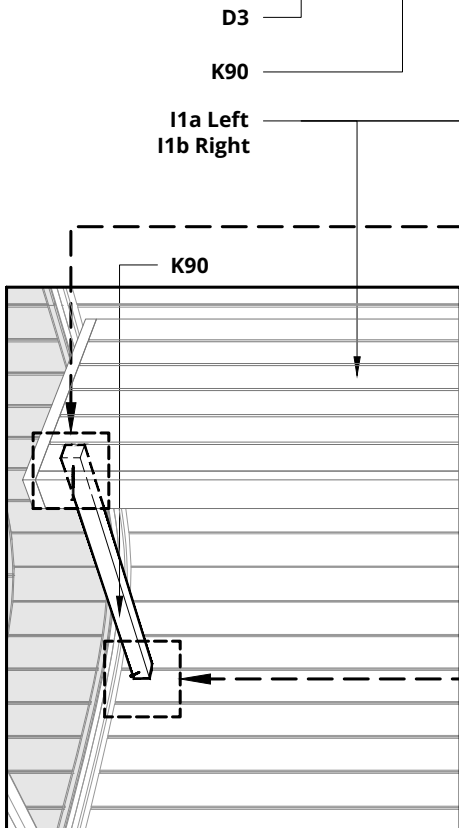

S5	Screws 4,5x60 for Spruce Screws 4,2x55 for Thermo	x4
S7	Screws 4,5x80 for Spruce Screws 4,2x75 for Thermo	x6
		

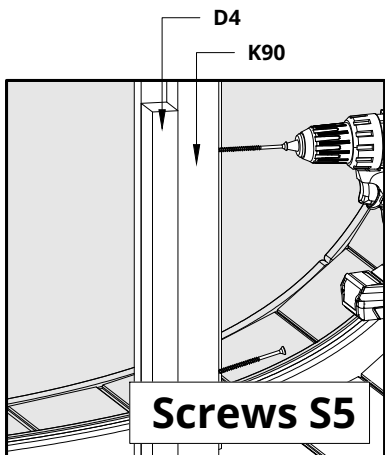
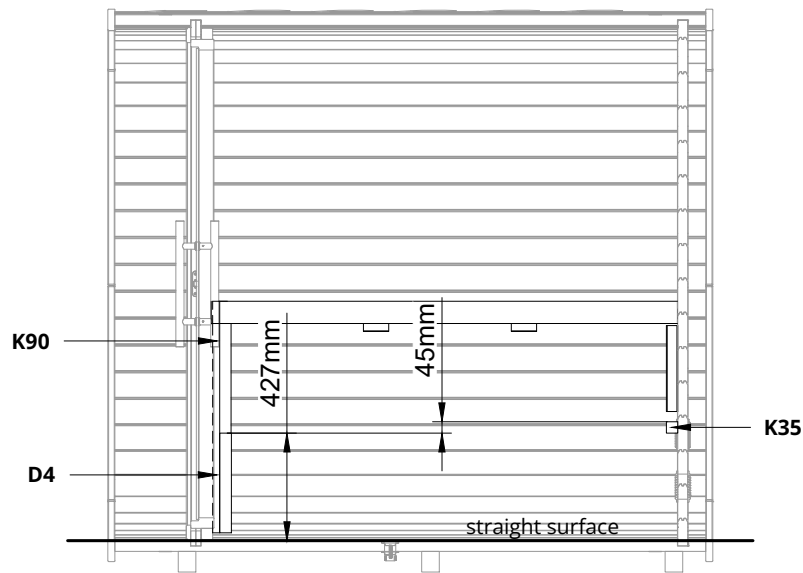
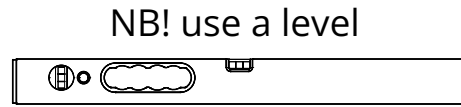

The cover board is longer, it must be cut to the correct size.
Height measurements are measured from a straight surface.

First install cover board piece D4. Mark the upper edge of D4 cover board piece.

Measure from the marked point to the floor to get the measurement. Cut the D4 cover board piece to size.

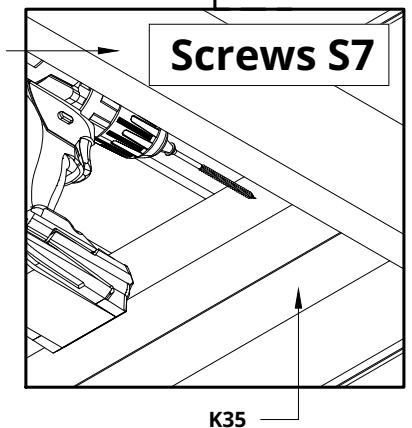
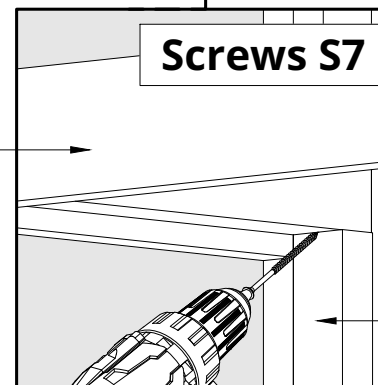
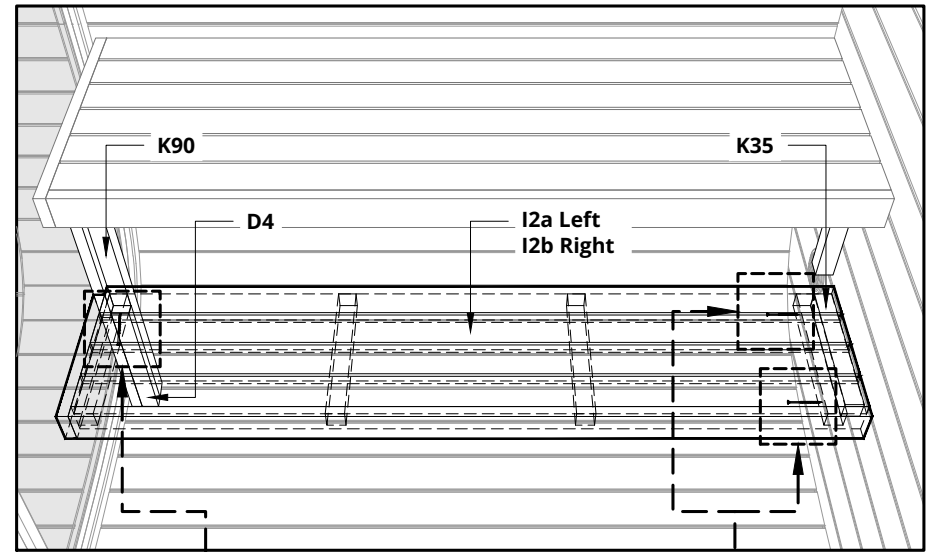

Attach the D4 cover board piece to K90 square wood with two S5 screws.

Now install and fix the I2a bench to the wall mounts K35 with two S7 screws and to K90 with one S7 screw.

Install an aid to keep the bench level.

Repeat these steps on the other side as well!

S5	Screws 4,5x60 for Spruce Screws 4,2x55 for Thermo	x20

NB! use a level

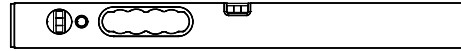

Notice!

Drill 4mm hole in the K.. square woods before screwing.

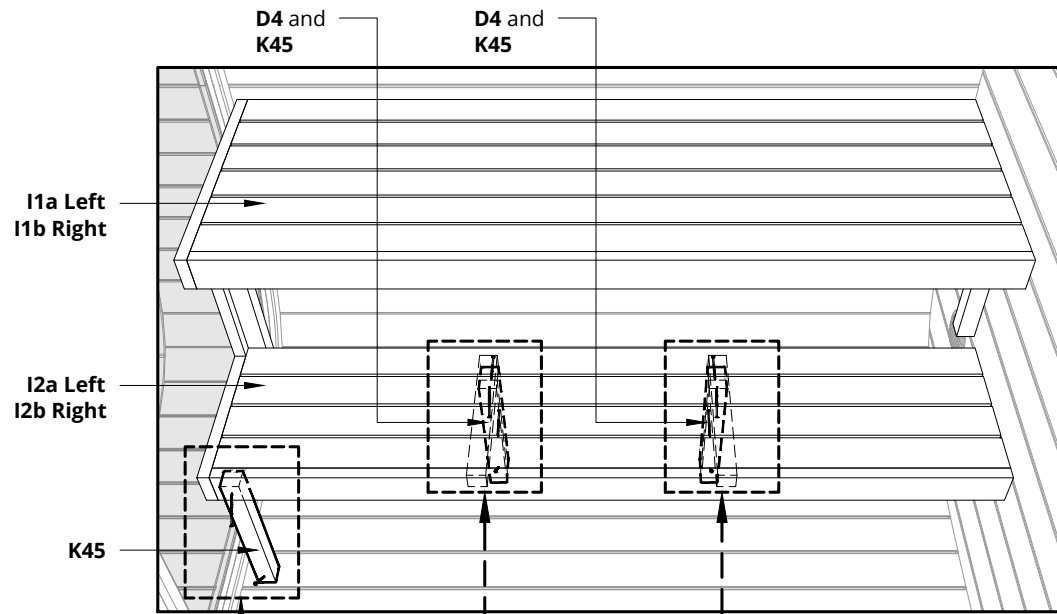
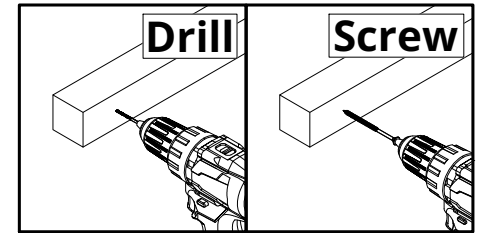

*The measurement must be started from the lower edge of the square wood attached under the bench.
The square wood and cover board are longer, they must be cut to the correct size.*

Please countersink the screw heads that are hidden behind the other part!

First measure and install the corner leg K45 of the middle bench I2a. Measure from the bench to the floor. Cut the K45 to size. If it is cut correctly, make sure that square wood K45 stays perpendicular to the bench when attaching it.

Next, install the two middle legs K45 of the middle bench I2a. Measure from the bench to the floor. Cut the K45 to size. If it is cut correctly, make sure that square wood K45 stays perpendicular to the bench when attaching it.

Now install cover boards D4 on the middle legs K45. Measure from the bench to the floor. Cut the D4 to size and install to the K45 legs with two screws each as shown in the picture.

Repeat these steps on the other side as well!

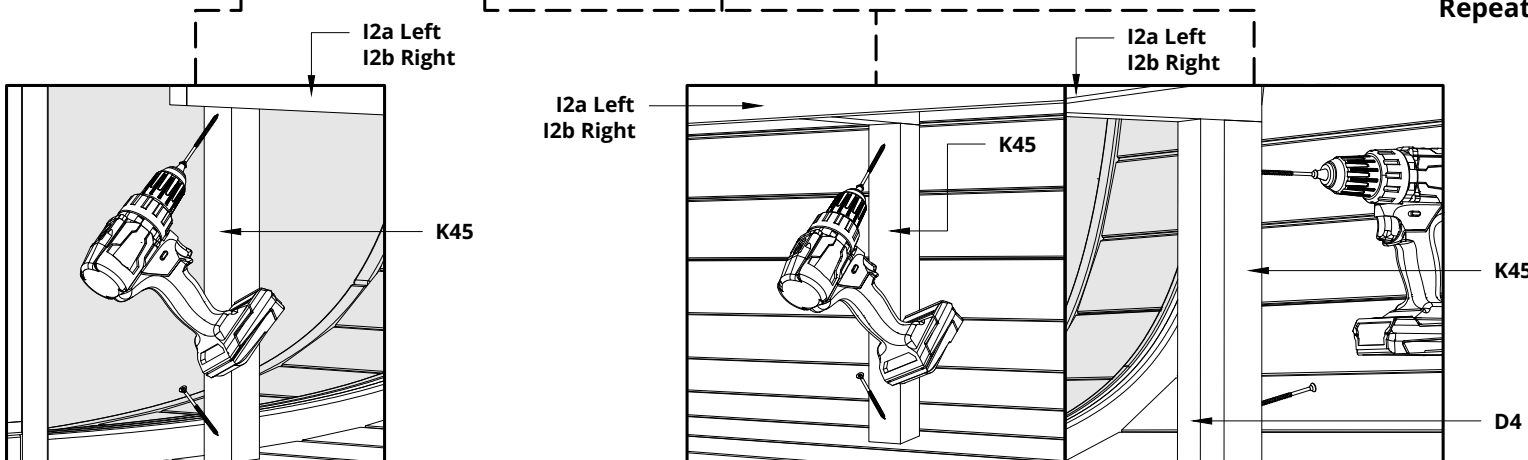

S5	Screws 4,5x60 for Spruce Screws 4,2x55 for Thermo	x16

NB! use a level

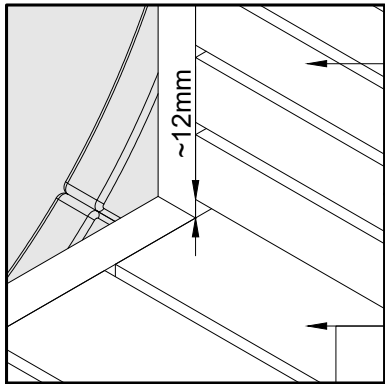
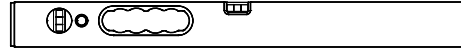

I3

~12mm

I2a Left
I2b Right

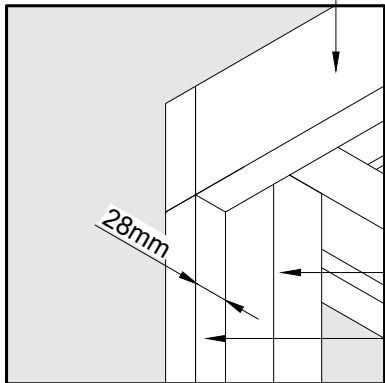

28mm

K45

D5

D4

D5

K45

I2a Left
I2b Right

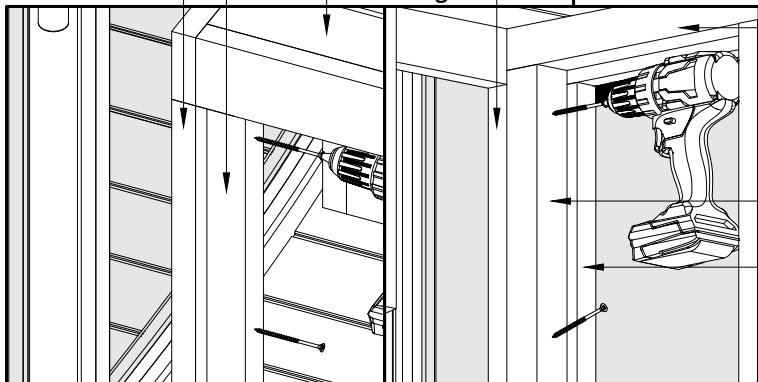

I2a Left
I2b Right

K45

D5

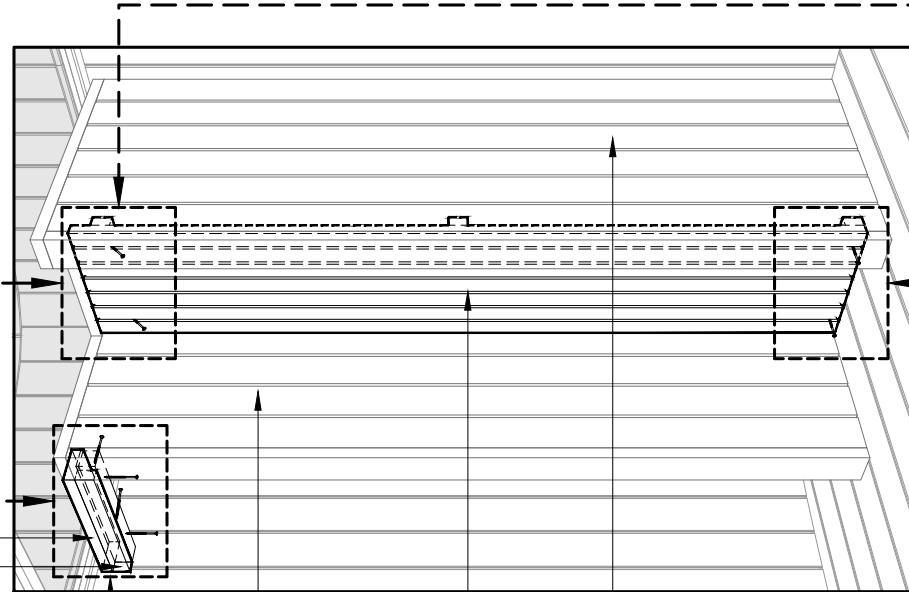

I2a Left
I2b Right

I3

I1a Left
I1b Right

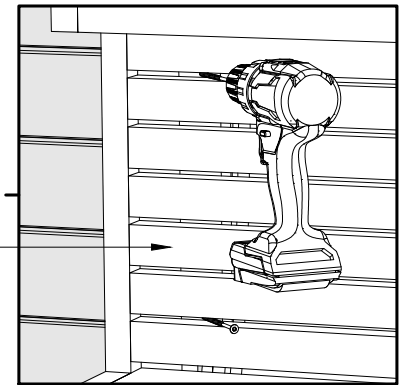

I3

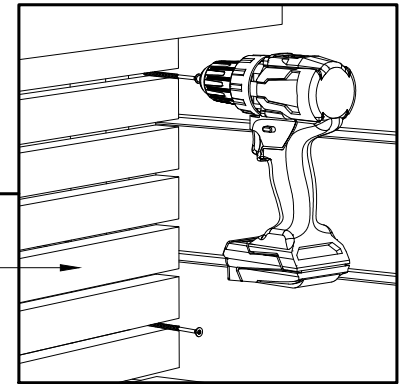

I3

The cover board are longer, they must be cut to the correct size.

First measure and install the corner leg K45 cover boards D4 and D5. Measure from the bench to the floor. Cut the D4 and D5 to size. First install cover board D4 and then D5. Both are attached with two screws to the corner leg **K45 square wood**.

Next install the bench skirt I3. It must be placed so that there is a small gap between the lower edge and the middle bench I2a. Fasten with four screws.

Repeat these steps on the other side as well!

S2	Screws 3x40	x6
S5	Screws 4,5x60 for Spruce Screws 4,2x55 for Thermo	x6
		

NB! use a level

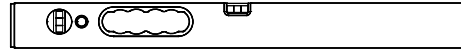

The height of the lower edge of the backrest is shown in the picture.

When you install the bench backrest I4. It needs to be set from the bottom edge as the wall is not flat. For leveling, use S2 screws, putting them behind the block with which the backrests are against the wall. At the beginning, screw the screws in, leaving 20 mm out, then, if necessary, turn them inward or outward. Or use spacer blocks.

Repeat these steps on the other side as bench backrest I4 well!

Next, place the step bench I5 on the left and also on the right, then place the floor mat.

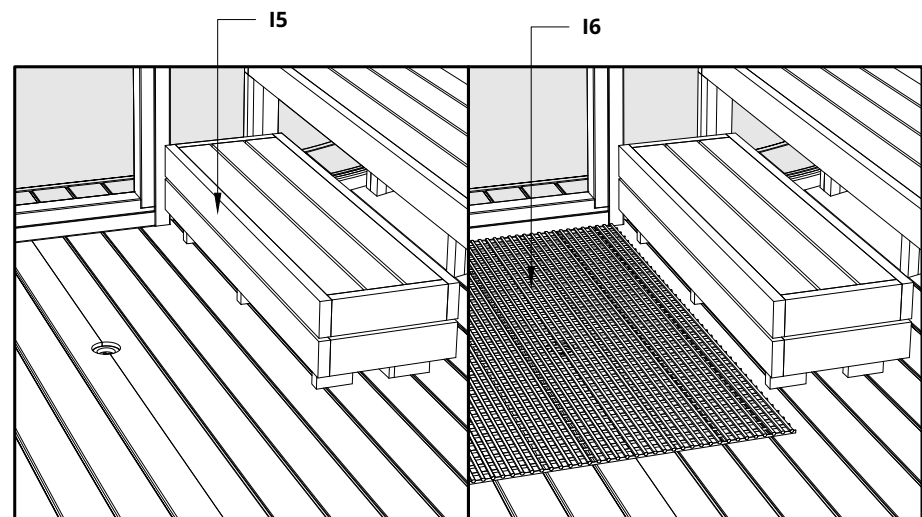
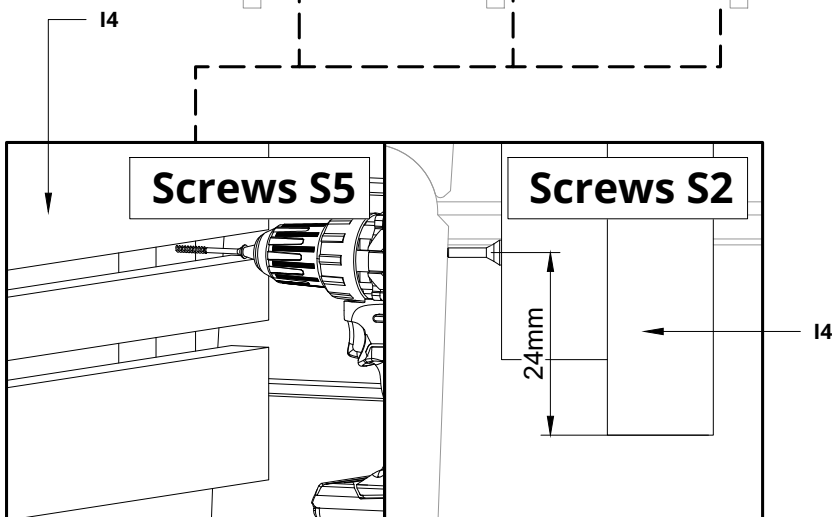
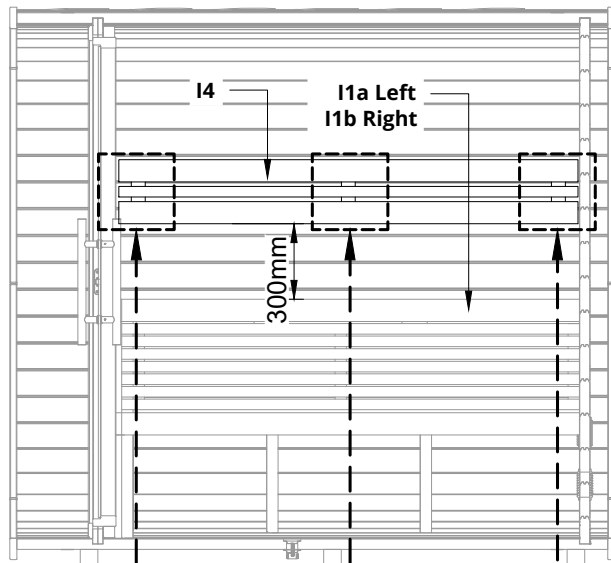

DOOR ADJUSTMENT MANUAL

1) Vertical adjustment of the door sash

The hinge on the side of the sash has a height adjustment bolt (fig.1), from which is possible to adjust the distance between the hinges. Turning clockwise, the hinges move further apart, and the door sash moves higher. It must be remembered that all hinges should be equally set at the same height, so as not to burden just one hinge.



Fig.1 Sash hinge height adjustment bolt

2) Horizontal adjustment of the door sash

The horizontal adjustment of the door sash can be done through the hinge on the frame (fig.2). Turning the bolt clockwise moves the sash closer to the hinge, turning counter-clockwise, moves the sash away from the hinge. The door sash should be adjusted so that the frame is at an equal distance from the edge of the frame. When turning the bolt, you should manually support the sash in the same direction so as not to bend the hinge.



Fig.2 Frame horizontal direction adjustment bolt

3) Adjusting the depth of the door frame

The distance of the door sash to the door frame can be adjusted both by the hinges (fig.3) and by the lock (fig.4). The distance between the sash and the frame can be adjusted by the hinges by turning the bolt in Fig.3 – clockwise, the sash moves closer to the frame, counter-clockwise further. The distance between the door sash and the frame on the lock side can be adjusted by bending the metal “ears” in figure 4 apart with a screwdriver. If necessary, the “ears” can also be bent back with a screwdriver.



Fig.3 Door sash depth adjustment bolt

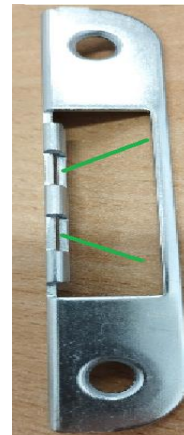

Fig. 4 Depth adjustment points on the lock side

4) Door finishing guide

- Clean the door from dust and dirt
- Remove or cover the lock, handles and hinges
- The product to be finished, must be dry and dust-free
- Finish the door with a suitable primer (NB! Finish both sides of the door)
- Finish the door with a substance suitable for outdoor conditions

Finishing is important so that the door maintains smooth closing and is durable in outdoor conditions.

ADJUSTING THE HINGES

- Remove plastic from hinges (first picture). To remove plastic, lift it from the places indicated by the red lines;
- To regulate hinges you need TORX 30 bit and cordless drill;
- Loosen the bolt shown in figure slightly. (DO NOT OPEN COMPLETELY);
- If both hinge bolts are slightly loosened, it is possible to move the glass in the directions shown in the figure;
- If the glass is set to the required distance, the bolts must be tightened again.



ADJUSTMENT OF THE ROLLER-LOCK

- PH2 screwdriver required;
- The roller lock can be adjusted by turning the screw indicated by the red line;
- Turning clockwise moves the roller inward and turning counter-clockwise moves the roller outward;
- The roller should be adjusted so that the glass moves freely behind the roller without applying force.



Glass door handle

Before installing the glass on the door, the handle must be disassembled.

Part:

1. - metal handle
2. - wooden handle
3. - 4x set screw for fixing handle
4. - 2x bolts
5. - 2x cone bushings
6. - 4x cover caps for handles
7. - 4x plastic washer
8. - 2x plastic bushing

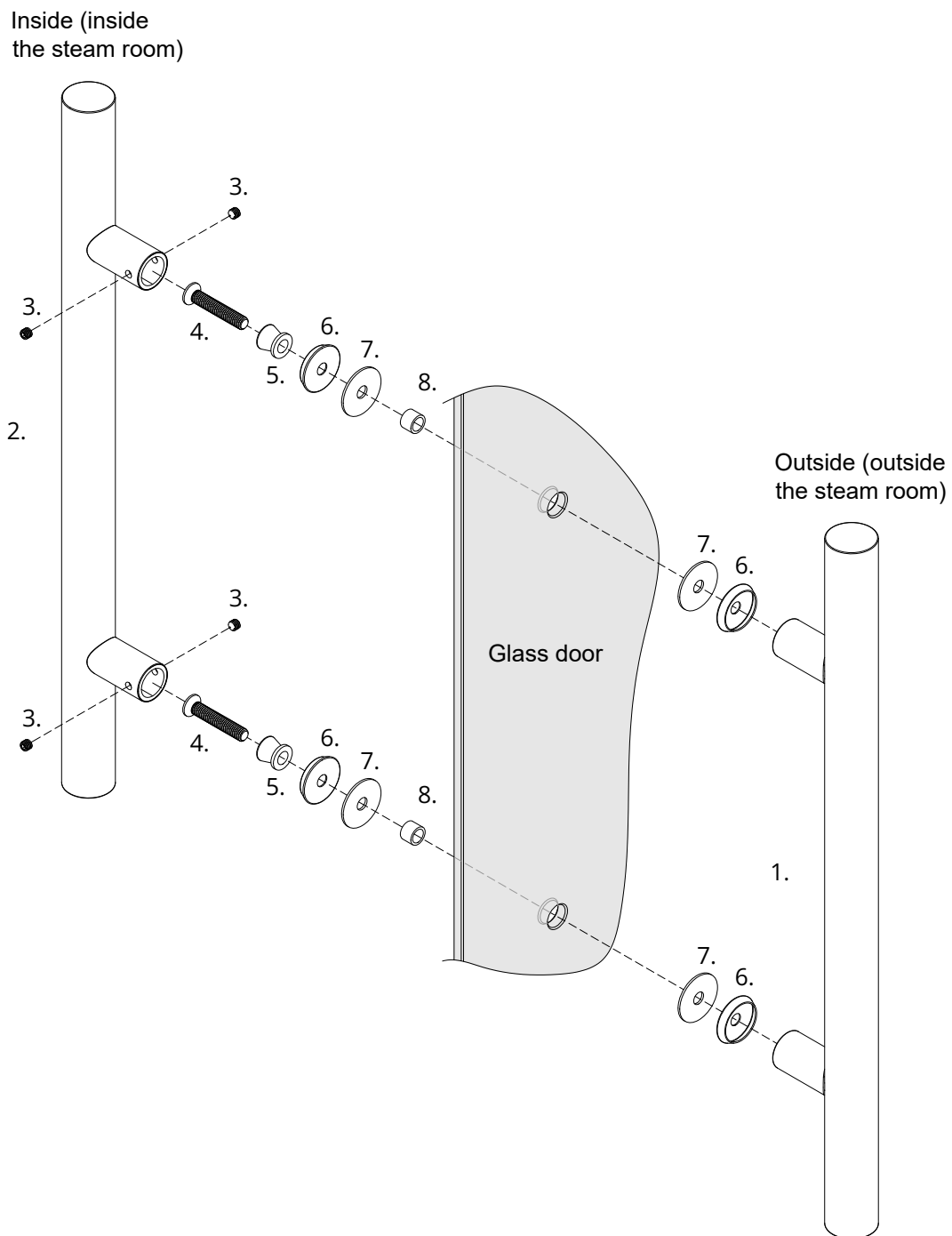

Order of installation

2X (4 - 5 - 6(inside the steam room) - 7(inside the steam room) - 8 - Glass door - 7(outside the steam room) - 6(outside the steam room)) - 1 - 2 - 3

USER MANUAL OF THE SAUNA

1. It is recommended to install the sauna above ground level to prevent the legs of the sauna from coming into direct contact with the ground. Install a water-resistant material, such as bitumen strips, between the legs of the sauna and the base.
2. Make sure that the surface on which you install the sauna is levelled and stable both before and after installing the sauna. Otherwise, the doors of the sauna may not open and close properly.
3. If the top part of the chimney has not been installed upon delivery of the sauna, it should be placed into the chimney pipe from the roof of the sauna.
4. During the first heating of the sauna, it must be constantly supervised and the doors should be kept open, as the stove emits a specific smell when first heated. Read more from the user manual of the sauna stove.
5. The maximum permitted temperature of the steam room is **+90 °C**. If heated to a higher temperature, the sauna may be overheated.
6. After each use of the sauna, it is recommended to keep the stove warm, the doors open, and the footrests up for a while to allow the sauna to dry from the inside. If necessary, the water on the floor should be directed to the drain with a floor scraper to avoid damage caused by excess humidity.
7. **When the weather is humid and if the wood has expanded, the metal hoops around the sauna should be loosened to avoid breaking the clamps and jamming the doors.** The hoops can be adjusted from the nut of clamp M12 located on the side of the sauna. To alleviate excess tension on the clamp and the hoop itself, loosen nut M12 (wrench no. 19) until the hoop can be shifted left and right. Then, re-tighten the nut until the hoop is under slight pressure and pressed fully against the wood so that it cannot be pulled away from the walls of the sauna. **When the weather is less humid and the wood has dried, the metal hoops around the sauna should be tightened from nut M12.** Tighten the nut so the hoop is under slight pressure. The hoop must be pressed fully against the wood so that it cannot be pulled away from the walls of the sauna. Saunasell OÜ is not liable for damage caused to the sauna due to a broken hoop clamp.
8. If the door is shifted out of place when the hoops are tightened, lift the exterior door off the hinges and regulate the hinges. If this is not a sufficient solution, remove the trims of the door and unscrew the screws of the doorframe beneath them. This will relieve the pressure on the door. If necessary, the opening of the door may be made wider, after which the screws should be re-tightened and the trims and door reinstalled.
9. The interior door should be regulated from the stopper and, if necessary, the hinges. If this is not a sufficient solution, remove the trims of the door and unscrew the screws of the doorframe beneath them. This will relieve the pressure on the door.
10. Locking the sauna door from the inside is prohibited.
11. In order to avoid damage caused by the weight of snow, any snow should be removed from the roof of the sauna. Keep in mind that the roof covering should not be damaged during snow removal.
12. If your sauna has lighting, install a 3G 2,5 mm² outdoor power cable and connect it in juniper box provided with the sauna (L1 – brown , N – blue , GR – green-yellow). The power cable of the sauna must be connected to a residual-current circuit breaker! Consult an electrician if necessary.

Maintenance of the sauna

1. **The interior surfaces of the sauna, the window frames of the steam and washing room, and the frames of interior doors must be treated with a special substance before initial use to protect them from humidity and dirt and extend the useful life of the sauna.** Later, this should be done once or twice a year. TEKNOS Satu Saunasuoja or Tikkurila Supi Saunasuoja may be used for this.
2. **Before initial use of the sauna, the benches and footrests must be treated with a protective oil to extend their useful life.** Later, this should be done once or twice a year. TEKNOS Satu Laudesuoja or Tikkurila Supi Laudesuoja may be used for this.
3. **Before initial use of the sauna and once a year after that, the door, doorframe, threshold, and window frame of the anteroom as well as the floors of the washing room and anteroom should be treated with the lacquer Teknos Helo Aqua 40.**
4. **The exterior surfaces of the sauna are given the first protective coating during production. The second coating should be applied approximately two months after purchasing the sauna to extend its useful life and maintain its appearance.** Use Remmers Aidol HK-Lasur for this. The substance is available for purchase at Saunasell OÜ or from the website <https://trendwood.ee/tooted/viimistlus/remmers/>
5. Saunasell OÜ is not liable for damage caused to the sauna due to insufficient maintenance or no maintenance at all.

WARRANTY

- The products have a 24-month warranty covering material and production defects, taking effect from the delivery of the sauna to the client.
- The warranty is valid if the user has reviewed the user manuals and abides by them.
- The warranty is void if the sauna has not been assembled by Saunasell OÜ.
- Please note! The warranty period differs for products on trailers and products intended for commercial use.
- The warranty does not cover defects characteristic of wood, such as discoloration, changes, issues, or cracks caused by alternating or excess humidity, etc.
- The warranty does not cover normal wear and tear of the product caused by its use and damage caused by incorrect installation or use is not compensated.
- The warranty does not cover damage caused by thunder or other weather phenomena.
- The warranty does not cover damage caused by incorrect installation by the client.
- The warranty expires when attempts are made to independently change or fix the product or if it is not used for its intended purpose.
- The warranty is void if the product is stored in an incorrect position or in the wrong conditions.
- The warranty is valid if the buyer informs the seller of the defect within a reasonable time (7 days).