



Machine Specification

67-28-5

Effective: July 16, 2018
Replaces: April 14, 2011

BEL 505^{G3} VERSA PACK

Semi-Automatic Case Former / Packing Station

The BEL 505^{G3} folds the bottom flaps of RSC case blanks opened and presented down into it by an operator and then firmly holds the case ready for packing. The 'G3' series has an open front-end design that keeps the machine length as short as possible and promotes erecting and filling cases from the front end as well as both sides. As the filled [or empty] case is pushed out of the 505^{G3} into an adjacent case sealer or onto a packing conveyor, it resets itself automatically ready to receive the next case blank. The BEL 505^{G3} is entirely pneumatically operated and requires only compressed air at 80-90 psi. / 6 Bar.

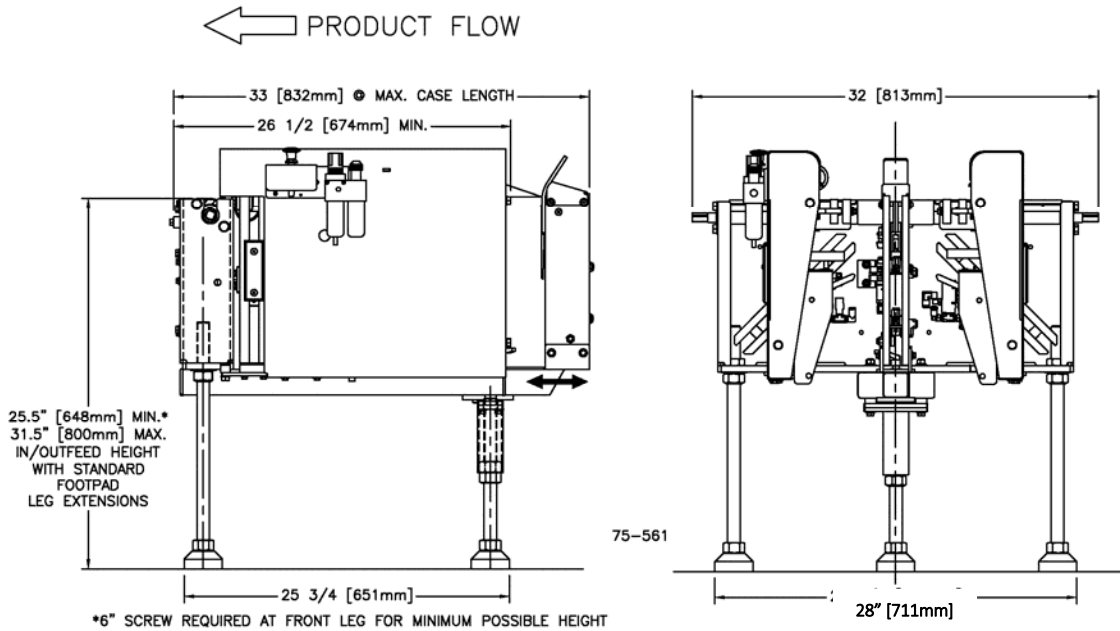

Standard Machine Specifications

		Length	Width	Height
Case Size Range	Minimum	8" / 203mm	6" / 152mm	3" / 89mm
	Maximum	24" / 610mm	18" / 457mm	unlimited
In/Outfeed Height				
With adjustable leg extensions [foot pad]	Minimum*	25.5" / 648mm		
	Maximum	32" / 813mm		
Speed		Up to 15 cases / min.		
Shipping Weight	Approx.	300 lbs. / 136 kg.		

* Minimum height requires exchange of the 12" single front leg screw with 6".

For further detail, see Layout Drawing 75-561

Construction

Frame and major components are zinc-plated steel, covers and fasteners are stainless steel. Some components are of anodized aluminum or engineering plastics.

Compressed Air Requirements

0.1 CF/Cycle @ 80-90 P.S.I. (6 Bar)

Safety Provisions

A case opened from a flat blank and held by hand must contact 3 separate control valve levers before machine will actuate to fold the bottom flaps. By holding and guiding the case by the top flaps, the operator's hands remain outside the machine perimeter and its moving parts are behind guards.

Nameplates / Identification

The machine Model Number and Serial Number appear on a nameplate and the serial number is stamped onto the machine frame.

Documentation

- On-machine illustrated adjustment and operating instruction labels
- Operation & Service Manual - providing set up, operating and troubleshooting information
- Technical Reference – spare parts kits, assembly and parts reference drawings, pneumatic control diagrams

Warranty

On Machinery and Parts manufactured by the Company, Wexxar Packaging Inc. (the "Company") warrants to the original purchaser ("Buyer") of the product described above (the "Product") that:

- (a) all non-moving, structural components of the Product (excluding hot melt systems and tapeheads) in all material respects, will be free of defects due to imperfect material or workmanship for a period of One (1) year from the date of invoice;
- (b) all powered mechanical parts of the Product, in all material respects, will be free of defects due to imperfect material or workmanship for a period of at least one (1) year from the time of shipping from the Company's factory;

and following Company's acceptance of a warranty claim, upon the Buyer's delivery of the defective Product to the Company's factory, the Company will repair or replace it at the Company's option.

The warranties set out above do not extend or apply to:

- (a) the routine replacement of parts due to normal wear and tear arising from use; this warranty does not extend to parts which may presumably be expected to wear out during the warranty period;
- (b) damage attributable to accident, misuse, improper maintenance, power surge, improper connection to a power source, placement of Product in hostile environment, or alterations not authorized by the Company, negligence, or accident;
- (c) accessories, attachments, parts or instruments sold with or attached to the Product that do not bear the Company's trade mark ("Components");
- (d) any warranty claims not made in writing to the Company at its head office within the applicable warranty period and within ten (10) days of Product failure.
- (e) This warranty does not cover shipping costs;

This warranty shall be the only warranty in effect and is made exclusive of all other warranties and guaranties written or oral, expressed or implied.

COMPONENTS	On request and to the fullest possible extent, the Company will assign to the Buyer any interest it has in Component suppliers' warranties for separately manufactured parts and accessories which form; are attached to; or constitute part of the Product. This includes tape heads.
CANCELLATION	Orders cannot be cancelled without consent of an authorized employee of the Company and in such cases the customer will fully indemnify the Company, unless agreed otherwise in writing by the Company.
TITLE	The title and right of possession of the goods quoted hereto shall remain with the Company and such goods shall remain Company property until all payments have been made in full. The purchaser agrees to do all that is required to maintain such right and title with the Company.
PRICE	All prices quoted are F.O.B. Company warehouse unless otherwise specified. Prices quoted are subject to change and do not include taxes or duties, if applicable.