



Lexmark CS820 Series

High-performance workgroup printing and professional-quality colour distinguish the Lexmark CS820, making it not just the fastest letter/A4 format colour laser printer in its class*, but the best value in features, supplies and service.

Speed for productivity

Class-leading speed: The CS820 is the fastest letter/A4 format colour laser printer in its class, and the first and only letter/A4 colour laser printer to break the 60 ppm speed barrier. Even large colour print jobs complete quickly so users are more productive.

Quick-output specialist: The CS820 can print one colour page as fast as 7 seconds. In fact, it can often print short jobs before a user gets up from their chair, and minimizes waiting time when printing is initiated from the touch screen.

Power printing: With a 1.33 GHz quad-core processor and 1 GB of standard memory, the CS820 has a powerful print controller to handle complex colour jobs with large, high-resolution photos and graphics spanning many pages. Its exclusive high-performance graphics chip drives real productivity.



Colour



Solutions



Up to 60 ppm



4.3-inch touch screen



Finishing option



Professional colour

Accurate colour: The CS820 series provides both PANTONE® calibration and embedded colour sample pages to help you nail perfect colour at the design stage. Lexmark Colour Replacement technology combines spot colour replacement and RGB replacement for precision matching of critical colours such as those found in corporate logos. It's colour so accurate, you can do everything in-house.

Ultra-sharp quality: The CS820 provides Lexmark's ultra-sharp 4800 Colour Quality (4800 CQ) at the default 60 ppm print speed.

Lexmark Managed Print Services (MPS)

Lexmark Managed Print Services (MPS) takes a holistic approach to improving the enterprise print architecture. Lexmark aligns devices with the business mission and takes care of their day-to-day management with proactive and predictive service to ensure optimal uptime. Once in place, the managed environment becomes a conduit to unify print and digital information for streamlined processes. Customers benefit with fewer devices, fewer pages, lower cost and improved knowledge worker productivity.

*Class is defined as A4 colour laser printers priced between \$1,500 and \$3,000 as of November 2015. Comparison based on manufacturers' web price and published speed specifications as reported by Buyers Laboratory (BLI), as of November 2015.

Solutions to solve business problems

Lexmark's Embedded Solutions Framework (eSF) and Cloud Solutions Framework (cSF) allow the CS820 to load and run software solutions tailored to your specific need or industry.

Lexmark devices with cSF can run web apps designed for the device, accessed via the cloud or an on-premise server. eSF applications are created by Lexmark, its partners and customers, and loaded directly on the device.

Solutions capabilities like that combine with Lexmark fleet management tools and your existing enterprise software and technical infrastructure to work within the Lexmark smart MFP ecosystem. Its adaptability future-proofs your investment in Lexmark colour laser technology.

Included eSF solutions

Forms and Favourites: Eliminate waste and inaccuracy associated with preprinted forms and other documents by locating and selecting forms from network storage locations or content management applications right from the CS820's touch screen. With the Forms and Favourites solution, you can print Microsoft® Office documents directly from the device, as well as PDF, XPS, JPG, PRN, TIFF and other file formats—useful when you're on the road or don't have a typical office computer to print from.

Eco-Settings: Print responsibly, save money and reduce waste by controlling energy usage and paper and toner consumption.

Display Customization: Display a customized, scrolling slideshow on the colour touch screen to communicate important messages to users while the printer is in Power Saver mode.



Forms and Favourites



Eco-Settings



Display Customization

Advanced media handling

High input capacity: The most advanced media handling capabilities of any letter/A4 colour laser printer has a maximum input capacity of up to 4,500 sheets. Higher input capacity reduces the chance that paper runs out, holding up print jobs until someone reloads.

Staple of business: The CS820 series offers a configuration that includes a compact, in-line staple finisher. Automatic stapling saves time when producing bound documents by eliminating the need to separate and manually staple groups of pages.

Media choices: The CS820 supports a broad media weight range, from 300 gsm—often used for signage and book covers—to tissue-thin paper such as 70 gsm. You can also use vinyl, labels, cardstock, envelopes and banners, with no media thickness worries.

Toner and long-life components

Toner for the long haul: Extra High Yield replacement toner cartridges produce up to 33,000 black and up to 22,000 colour pages to reduce the number of times toner runs out, keeping the output going strong in high-usage environments.

Long-life components: Constantly replacing components creates unnecessary waste and carbon emissions and hurts productivity as the printer stops and print jobs back up. The CS820's long-life components minimize downtime with imaging components that can last up to 300,000 pages, depending on usage. And with the option to continue printing colour pages in black if any of the colour cartridges run out, the CS820 lets you choose to keep your print jobs moving.

Quality in Unison: Unison™ Toner is the result of advanced toner science—powerful enough to deliver consistently outstanding image quality with rich, vibrant colour and precise details, plus long-life system reliability and amazing sustainability. Documents printed with Unison Toner look great from the first page to the last because of its uniquely engineered formulation. Even when the cartridge is low, there's no fading and no need to shake the cartridge, and you won't waste money by replacing a cartridge that still has toner in it.

Unison Toner's unique low-friction qualities increase toner flow and contribute to its ability to transfer efficiently to the page. Unison Toner reduces internal wear on long-life components and protects the print system. This delivers long-term reliability and ultimately saves time, money and the environment.

Unison Toner is uniquely tuned to the CS820's print system for optimal performance.



Security and more

Advanced security features: Lexmark CS820 security features encompass device management, hardening and operation.

Device management: A combination of administrative access and passwords, HTTPS, SMNPv3, IPsec and 802.1x support lets you remotely monitor, manage, authorize and authenticate who and what gets access to the network.

Device hardening: Built-in tools include port filtering and TCP connection filtering which restrict what connections are active from what sources. Encryption and wiping of the optional hard disk protect sensitive print job data. Digitally signed firmware updates can prevent hackers from uploading compromised software to the printer.

Device operation: You get user authentication via PIN, passwords or badge reader, address book lookup via LDAP over SSL (Secure Socket Layer) to provide a secure connection between the printer and the network, and device operator panel lockouts to protect the device settings.

Hard disk protection: Models equipped with the optional hard disk include advanced hard disk protection with 256-bit AES encryption and encryption keys stored in the printer's memory, not the hard disk. The data is almost impossible to read if the hard drive is removed. This level of protection is automatic at power up—users and administrators do not have to do anything.

The CS820 also performs automatic file-based hard disk wiping after every print job, which cannot be disabled. And the process of clearing a device's disk drive and non-volatile memory data when removing it from service or a secure location is simple with a one-step "out of service" wiping command for authorized users.

Take it easy

4.3-inch colour touch screen: The bright touch screen features an ultra-smooth surface and can be activated by almost anything, including pens, fingertips or nails—without pressure or direct skin contact. And support for gestures like swipe to access panels and menus makes operation easy and intuitive. Audible feedback from the screen provides user assurance, while a separate 10-key number pad improves accessibility and enhances convenience.

Intuitive interface: The e-Task interface with modern tablet-like capabilities is familiar to users, minimizing the need for training. On-screen features like print preview and late job customization allow users to select specific pages within a document and change print job settings such as staple or duplex at the device.

Wireless and mobile printing: Lexmark Print Management was the first AirPrint®-certified enterprise print management solution. Lexmark mobile printing includes support for iOS, Android, and Microsoft® Windows Mobile printing, with optional wireless and NFC direct connectivity from smartphones and tablets. The CS820 is a Mopria®-certified printer and is Google Cloud Print™ Ready.

Accessibility: The CS820 includes advanced Section 508 and European Standard EN 301 549 accessibility features for those with varying levels of ability. Features such as an operator panel that tilts from almost horizontal to almost vertical, paper trays that can be closed with less than five pounds of force, standard headphone jack and standard talk-back⁶ feature provide a better user experience for all of our customers.

Direct printing: Directly print Microsoft Office files, PDFs and other document and image types from flash drives, network servers or online drives.

Built for planet earth

Advanced toner: Lexmark's exclusive Unison Toner makes energy savings a reality, using less energy than Lexmark's previous toners by printing at a lower temperature. And through LCCP, the Lexmark Cartridge Collection Program, Lexmark offers a free and easy way for you to return your empty cartridges for sustainable recycling or remanufacturing.

Power saving modes: Sleep mode power usage of less than 3 watts saves money and energy between print jobs. When the printer is not in use, it goes to sleep and wakes for incoming print jobs. In addition, it can be powered on or off from its control panel or a user-defined schedule.

Paper and toner savings: Standard duplex printing prints on both sides of paper by default. Plus, the unique ColourSaver feature prints images at a lighter shade by default, while leaving text dark and readable, saving toner and money.

And the included Eco-Settings solution lets you print using predefined settings like duplex and pages per sheet to further save paper.

Environmental certifications: Lexmark products meet globally recognized environmental standards†.

- ▶ ENERGY STAR®
- ▶ Blue Angel
- ▶ EPEAT® Gold

Lexmark Sustainability

For Lexmark, commitment to the environment isn't a marketing tagline, it's a core value backed up by real action and results. We are forward thinking, innovative, and driven to sustain a healthy planet for generations to come. For our customers and partners we bring this passion, our leading technology and a deep understanding of industry-specific business processes to continuously improve their efficiency as well as our own.

For more information on Lexmark's sustainability initiatives, visit csr.lexmark.com.

†Energy Star V2.0 for Imaging Equipment (EU RoHS and Section 4.3.1.1 of IEEE 1680.2-2)

1. Intuitive colour touch screen with next-generation e-Task interface

The 4.3-in. colour touch screen features an ultra-smooth surface and can be activated by almost anything, including pens, fingertips or nails—without pressure or direct skin contact. The modern interface is familiar to users, minimizing the need for training.

2. Expandable input

Print on multiple paper types and boost input capacity to 4,500 sheets.

3. Direct printing

Print Microsoft Office files, PDFs and other document and image types from flash drives, or select and print documents from network servers or online drives.

4. Optional staple finisher

The optional compact, in-line staple finisher saves time when producing bound documents.

5. Unison Toner print system with long-life supplies

Unison Toner delivers consistently outstanding image quality plus long-life system reliability and amazing sustainability in an innovative no-shake design. Extra High Yield replacement toner cartridges produce up to 33,000 black and up to 22,000 colour pages.

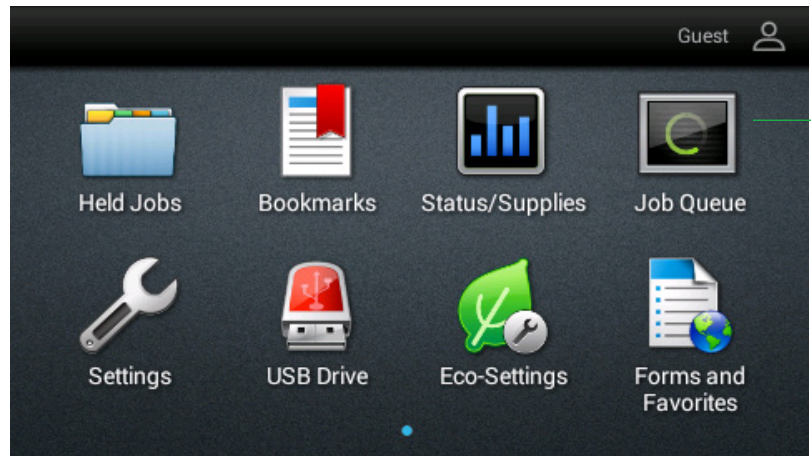

Lexmark CS820 Series features

Product specifications	Lexmark CS820de	Lexmark CS820dte	Lexmark CS820dtfe
Printing			
Display	Lexmark e-Task 4.3-inch (10.9 cm) colour touch screen		
Print Speed: Up to ⁶	Black: 60 ppm / Colour: 60 ppm		
Time to First Page: As fast as / Time to First Page: as fast as	Black: 7 seconds / Colour: 7 seconds		
Print Resolution	Black: 1200 x 1200 dpi, 4800 Color Quality (2400 x 600 dpi) / Colour: 1200 x 1200 dpi, 4800 Color Quality (2400 x 600 dpi)		
Memory	Standard: 1024 MB / Maximum: 3072 MB		
Hard Disk	Option available		
Recommended Monthly Page Volume ²	2500 - 25000 pages		
Maximum Monthly Duty Cycle: Up to ³	200000 pages per month		
Supplies⁷			
Laser Cartridge Yields (up to) ¹	22,000-page Colour (CMY) Extra High Yield Cartridges, 33,000-page Black Extra High Yield Cartridge, 8,000-page Black and Colour (CMYK) Cartridges		
Photoconductor Estimated Yield: Up to ⁵	175000 pages, based on 3 average letter/A4-size pages per print job and ~ 5% coverage		
Developer Unit(s) Estimated Yield: Up to ⁵	300000 pages, based on 3 average letter/A4-size pages per print job and ~ 5% coverage		
Cartridge(s) Shipping with Product ¹	8,000-page Black and Colour (CMYK) Return Program Toner Cartridges		
Paper Handling			
Included Paper Handling	550-Sheet Input, 100-Sheet Multipurpose Feeder, Integrated Duplex, 500-Sheet Output Bin	550-Sheet Input, 100-Sheet Multipurpose Feeder, Integrated Duplex, 550-Sheet Tray, 500-Sheet Output Bin	550-Sheet Input, 100-Sheet Multipurpose Feeder, Integrated Duplex, 550-Sheet Tray, 500-Sheet Output Bin, Inline Stapler
Optional Paper Handling	550-Sheet Tray, Inline Stapler, 2200-Sheet Tray		550-Sheet Tray, 2200-Sheet Tray
Paper Input Capacity: Up to	Standard: 650 pages 20 lb or 75 gsm bond / Maximum: 4500 pages 20 lb or 75 gsm bond	Standard: 1200 pages 20 lb or 75 gsm bond / Maximum: 4500 pages 20 lb or 75 gsm bond	
Paper Output Capacity: Up to	Standard: 500 pages 20 lb or 75 gsm bond / Maximum: 500 pages 20 lb or 75 gsm bond		Standard: 300 pages 20 lb or 75 gsm bond / Maximum: 300 pages 20 lb or 75 gsm bond
Media Types Supported	Card Stock, Dual Web Labels, Envelopes, Labels, Plain Paper, Polyester Labels, Vinyl Labels, Banner Paper, Refer to the Paper & Specialty Media Guide		
Media Sizes Supported	10 Envelope, 7 3/4 Envelope, 9 Envelope, A4, A5, B5 Envelope, C4 Envelope, C5 Envelope, DL Envelope, Index Card, Executive, Folio, JIS-B5, Legal, Letter, 4 x 6", Statement, Universal, Oficio, A6		
General Information⁴			
Standard Ports	One Internal Card Slot, USB 2.0 Specification Hi-Speed Certified (Type B), Gigabit Ethernet (10/100/1000), Front USB 2.0 Specification Hi-Speed Certified port (Type A), Two Rear USB 2.0 Specification Hi-Speed Certified ports (Type A)		
Optional Network Ports	Internal MarkNet N8360 802.11b/g/n Wireless, NFC		
Noise Level: Operating	Print: 56 dBA		
Specified Operating Environment	Humidity: 15 to 80% Relative Humidity, Temperature: 10 to 32°C (50 to 90°F), Altitude: 0 - 2896 Meters (9,500 Feet)		
Limited Warranty - See Statement of Limited Warranty	1-Year Onsite Service, Next Business Day		
Size (mm - H x W x D) / Weight	535.9 x 558.8 x 522.4 mm / 62.3 kg	655 x 558.8 x 522.4 mm / 71.7 kg	690 x 646 x 522.4 mm / 75.9 kg

¹Average continuous black or continuous composite CMY declared cartridge yield up to this number of standard pages in accordance with ISO/IEC 19798. ²"Recommended Monthly Page Volume" is a range of pages that helps customers evaluate Lexmark's product offerings based on the average number of pages customers plan to print on the device each month. Lexmark recommends that the number of pages per month be within the stated range for optimum device performance, based on factors including: supplies replacement intervals, paper loading intervals, speed, and typical customer usage. ³"Maximum Monthly Duty Cycle" is defined as the maximum number of pages a device could deliver in a month using a multishift operation. This metric provides a comparison of robustness in relation to other Lexmark printers and MFPs. ⁴Printers are sold subject to certain license/agreement conditions. See www.lexmark.com/printerlicense for details. ⁵Actual Yield may vary based on other factors such as device speed, paper size and feed orientation, toner coverage, tray source, percentage of black-only printing and average print job complexity. ⁶Print and copy speeds measured in accordance with ISO/IEC 24734 and ISO/IEC 24735 respectively (E⁵AT). For more information see: www.lexmark.com/ISOspeeds. ⁷Product functions only with replacement cartridges designed for use in a specific geographical region. See www.lexmark.com/regions for more details.

This is a Class A device according to the FCC Rules and international electromagnetic emissions standards. This device is not intended for use in residential or domestic environments due to potential interference to radio communications.

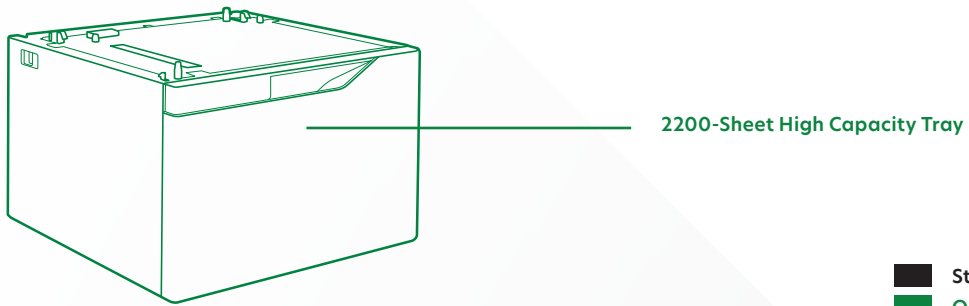
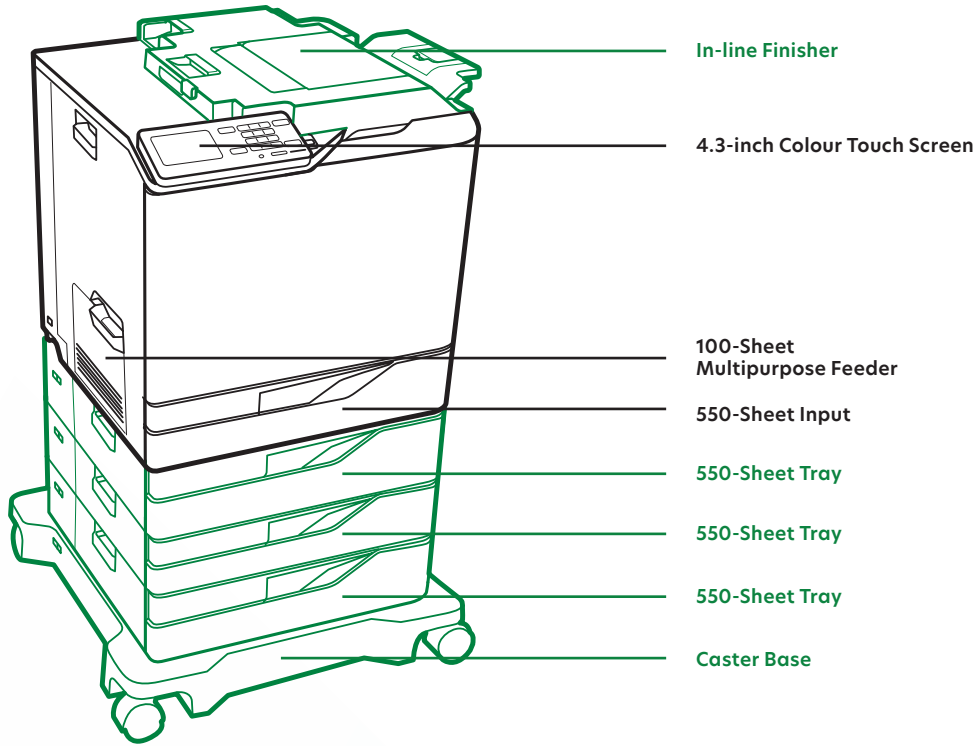

Standard
 Optional

© 2016 Lexmark and the Lexmark logo are trademarks of Lexmark International, Inc., registered in the United States and/or other countries. All other trademarks are the property of their respective owners.

Unison™ is a U.S. registered trademark.

AirPrint and the AirPrint logo are trademarks of Apple Inc.

ENERGY STAR® is a U.S. registered mark.

EPEAT® is a trademark of EPEAT, Inc. in the United States and other countries.

Google Cloud Print™ is a trademark of Google Inc.

Mopria®, the Mopria® Logo and the Mopria® Alliance logo are registered trademarks and service marks of Mopria Alliance, Inc. in the United States and other countries. Unauthorized use is strictly prohibited.

Notice: "This product includes software developed by the OpenSSL Project for use in the OpenSSL Toolkit (<http://www.openssl.org/>)."