

**UNION
BUTTERFIELD®**

FLASHTAP
Service

**FLASHTAP THREADING PROGRAM
COMBINED CATALOG/PRICE LIST
USA**

2019



Table of Contents

6 – 13	Semi-Special Taps (Machine Screw, Fractional)
14 – 17	Semi-Special Taps (Metric)
18	Made-To-Order HSS Hand & Spiral Point Taps
19	Made-To-Order Hand Taps (Large Sizes)
20	Made-To-Order Spiral Flute Taps
21	Made-To-Order Pipe Taps/Thread Forming Taps
22-25	USCTI Tables
22-23	» Hand Taps (USCTI Table 302)
24	» Fine Pitch Taps (USCTI Table 303)
25	» Pipe Taps (USCTI Table 311)
26	Warranty

The pricing in this catalog has been designed to easily locate the correct tap size you need. These tools are listed in order by size and pitch.

If you cannot locate the tap you need,

- Refer to the USCTI Tables on Pages 22 – 25
- Contact your local distributor
- Call **800.639.1776**

All thread tolerances conform to national standards. Please specify the material being tapped at time of order.

FLASHTAP Service

SEMI-SPECIAL & MADE-TO-ORDER TAP PRODUCTS

We are pleased to present a carefully analyzed selection of semi-special tap products as a quick and reliable way to help solve your tap delivery requirements.

SHIPMENT WITHIN 24 HOURS OF RECEIPT OF ORDER (unless otherwise noted)

SURFACE TREATMENTS

All taps are standard bright finish

- Additional cost & delivery time will apply to items that are Steam Oxide, Bronze Oxide & Nitride
- Additional cost & delivery time will apply to items that are coated. TiN, TiCn, ZrN & TiAlN

ORDER PROCESSING

Orders are accepted through authorized distributors only.

Orders received after 2:30 PM EST will be processed the following business day. All orders are subject to a +/- 10% shipment.

NOTE:

- Special Taps in quantities greater than listed can be quoted to meet your specific delivery requirements.
- Special Tap Prices not covered by this price schedule are available upon request.
- Industry Standard \pm 10% shipment policy applies on quantities over six.

Our worldwide distributor network carries a complete stock of our products, and through their familiarity with local conditions, can provide efficient consumer service at the lowest possible price.

SEMI-SPECIAL STOCK TAPS - MACHINE SCREW, FRACTIONAL

Machine Screw Sizes (#0 - #14)
Fractional Sizes (1/8" - 2-1/2")

Includes:

Hand Tap	Oversize Spiral Point
Spiral Point	Double Lead Hand Tap
Left-Hand Hand Tap	Spiral Flute Hand Tap
Left-Hand Spiral Point	55° Modified Whitworth Pipe
Oversize Hand Tap	

SEMI-SPECIAL STOCK TAPS - METRIC

Carried in classes 6H and 4H

Includes:

Hand Tap
Spiral Point
Left-Hand Hand Tap
Oversize Hand Tap
Oversize Spiral Point

MADE-TO-ORDER SPECIAL STOCK HAND TAPS - HSS

Tables 302, 303 and 311
Straight Flute #0 - 1"
Straight Flute 1-1/16" - 2-1/2"
Spiral Flute #3 - 1"
Pipe (Straight or Taper)
Thread Forming

To Help Expedite Your Order . .

Correct terminology will minimize errors and expedite order entry. The following may be used as a guide in requesting special taps for your specific requirements.

Nomenclature

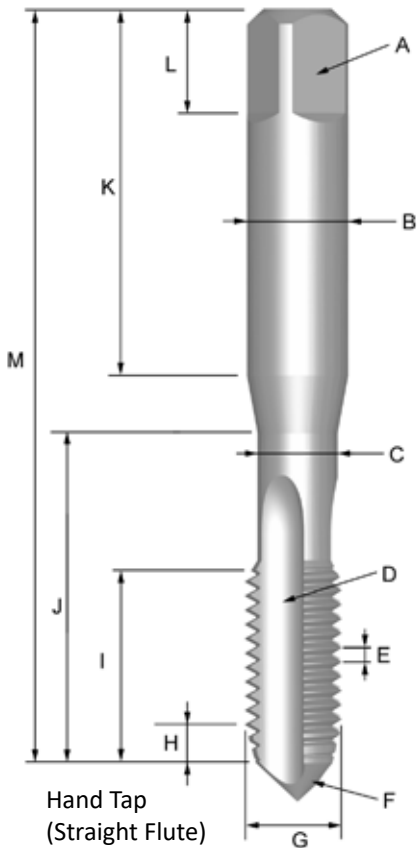

- A Square Across Flat
- B Shank Diameter
- C Recess Diameter
- D Flute
- E Pitch
- F External Centre (Male)
- G Thread Diameter (External)
- H Chamfer Lead Length
- I Thread Length
- J Recess Length
- K Shank Length
- L Square Length
- M Overall Length

Spiral Flute Tap Spiral Point Tap

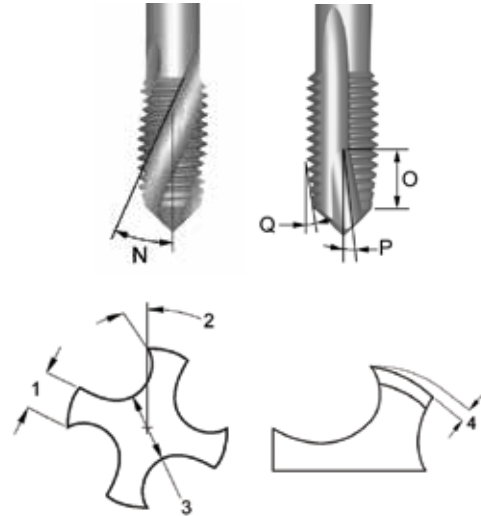

- 1. Land Width
- 2. Cutting Rake Angle
- 3. Web Diameter
- 4. Radial Thread Relief

Conversion of Millimeter Pitch to Threads per inch

Pitch in mm	Pitch in Inches	Threads per Inch (Ref)	Basic Thread Height
0.35	.01378	72.57	.00895
0.4	.01575	63.50	.01023
0.45	.01772	56.44	.01151
0.5	.01969	50.80	.01279
0.6	.02362	42.33	.01534
0.7	.02756	36.29	.01790
0.75	.02953	33.87	.01918
0.8	.03150	31.75	.02046
0.9	.03543	28.22	.02301
1	.03937	25.40	.02557
1.25	.04921	20.32	.03196
1.5	.05906	16.93	.03836
1.75	.06890	14.51	.04475
2	.07874	12.70	.05114
2.5	.09843	10.16	.06393
3	.11811	8.47	.07671
3.5	.13780	7.26	.08950
4	.15748	6.35	.10229
4.5	.17717	5.64	.11507
5	.19685	5.08	.12786
6	.23622	4.23	.15343

Thread Chamfers

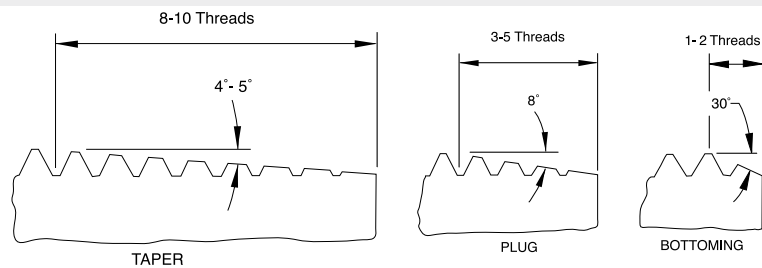

Examples of Tap Descriptions

Quantity	Nominal Size	Threads per Inch Metric Pitch	Form of Thread	Pitch Dia. 'H' Limit	Style Description	Chamfer Specs	R.H or L.H. Thread	Surface Treatment	Specific Material to be Tapped
48	1/4	28	NF	H2	Fast-Spiral	Plug	R.H.	TiN	Steel
12	M4	0.7	Standard	D4	Hand Tap	2 1/2 Thread	L.H.	—	Cast Iron
6	3/8	16	NC	H3	6" Extension Spiral Point	Plug	R.H.	—	—

Taps with any other special features will require a complete description as noted in the examples above.

The special taps covered in this price list will be produced according to the United States Cutting Tool Institute (USCTI) Standard Dimension Tables as referenced.

The seller reserves the right to overship or undership any order to the extent of ten (10%) percent of the total specified quantity.

Semi-Special Threading Program

Machine Screw

\$USD

SIZE	DESCRIPTION	O.D. TOL	# FLT	QUANTITY/LIST PRICE						TAPER EDP#	PLUG EDP#	BOTTOM EDP#	SHIPPING IN 24-48 HOURS (except where noted)
				1	2	3	6	12	24				
0-80 NF	Spiral Point	H3	2	67.83	65.29	62.63	43.98	26.78	22.00		1515008		
1-56 NS	Spiral Point	H1	2	67.83	65.29	62.63	43.98	26.78	22.00		1515020		
2-56 NC	L.H. Hand Tap	H2	2	65.96	61.82	59.97	43.04	25.18	20.12	1515037	1515038	1515039	
	Spiral Point	H3	2	92.88	71.84	63.56	46.37	27.98	22.25		1517734		
	Hand Tap	H4	2	91.15	70.53	62.10	44.64	26.38	20.65	1517762	1517763	1517764	
	Spiral Point	H4	2	92.88	71.84	63.56	46.37	27.98	22.25		1517735		
	Spiral Point	H5	2	92.88	71.84	63.56	46.37	27.98	22.25		1517668		
3-48 NC	Spiral Point	H7	2	92.88	71.84	63.56	46.37	27.98	22.25		1517691		
	L.H. Hand Tap	H2	3	62.36	61.82	57.29	37.71	21.46	18.12	1515049	1515050	1515051	
4-32 NS	Hand Tap	H2	3	91.67	62.04	49.44	34.11	20.26	16.12	1515061	1515062	1515063	
4-40 NC	Hand Tap	H3	3	52.50	51.71	45.18	27.98	15.99	12.13	1515079	1515080	1515081	72 hours
	L.H. Hand Tap	H2	3	48.43	48.22	47.92	29.49	18.66	15.73	1515073	1515074	1515075	
	Spiral Point	H3	2	75.14	62.76	50.47	32.41	17.63	15.95		1515078		
	+0.003 Spiral Point	H7	2	75.14	62.76	52.91	36.92	19.86	17.06		1517670		
	+0.005 Spiral Point	H11	2	73.01	60.87	52.91	36.92	19.86	17.84		1517557		
	52° Spiral Flute	H3	2	66.76	62.51	60.24	39.85	23.05	19.46		1517672	1517673	
4-48 NF	Spiral Point	H5	2	53.84	52.76	46.37	29.31	17.32	13.19		1517593		
	L.H. Hand Tap	H2	3	52.37	51.71	50.90	35.44	18.66	15.73	1515085	1515086	1515087	
5-40 NC	L.H. Hand Tap	H2	3	52.37	51.71	50.90	35.44	18.66	15.73	1515097	1515098	1515099	72 hours
	Spiral Point	H5	2	75.14	62.76	52.10	36.77	19.86	17.06		1517697		
	+0.005 Spiral Point	H11	2	75.14	62.76	52.10	36.77	19.86	17.06		1517675		
6-32 NC	L.H. Hand Tap	H3	3	29.85	22.39	14.92	11.24	8.95	7.46	1515109	1515110	1515111	72 hours
	Hand Tap	H5	3	84.49	55.09	40.91	25.05	14.00	11.59	1515121	1515122	1515123	
	Spiral Point	H5	2	85.45	55.96	41.98	26.25	15.06	12.53		1515120		
	+0.003 Hand Tap	H7	3	35.17	26.38	17.59	13.19	9.43	7.87	1515127	1515128	1515129	
	+0.005 Hand Tap	H11	3	35.17	26.38	17.59	13.19	9.43	7.87	1515133	1515134	1515135	
	+0.005 Spiral Point	H11	2	17.99	13.92	11.26	10.39	7.17	6.52		1515132		
6-40 NF	L.H. Hand Tap	H2	3	35.99	35.78	35.48	23.27	13.59	11.59	1515145	1515146	1515147	
	Spiral Pt.	H3	2	85.97	56.55	40.51	26.25	14.79	12.53		1515150		
6-48 NS	Hand Tap	H2	3	84.49	55.09	40.91	25.05	14.00	11.59	1515157	1515158	1515159	
8-24 NS	Hand Tap	H3	4	85.31	56.48	40.91	25.05	14.00	11.59	1515163	1515164	1515165	
8-32 NC	L.H. Hand Tap	H3	4	29.85	22.39	14.92	11.24	8.95	7.46	1515169	1515170	1515171	72 hours
	R.H. Hand Tap	H5	4	85.31	56.19	40.91	25.05	14.00	11.59	1515181	1515182	1515183	
	Spiral Point	H5	2	86.25	57.14	41.98	26.25	15.06	12.53		1515180		
	+0.003 Hand Tap	H7	4	35.17	26.38	17.59	13.19	9.43	7.87	1515187	1515188	1515189	
	+0.005 Hand Tap	H11	4	35.17	26.38	17.59	13.19	9.43	7.87	1515193	1515194	1515195	
	+0.005 Spiral Pt.	H11	2	38.69	29.01	19.34	14.51	9.90	8.26		1515192		
8-36 NF	L.H. Hand Tap	H2	4	42.91	41.57	40.91	25.05	14.00	11.59	1515205	1515206	1515207	
8-40 NS	Hand Tap	H2	4	85.31	56.19	40.91	25.05	14.00	11.59	1515217	1515218	1515219	
	Spiral Point	H2	2	86.25	57.14	41.98	26.25	15.06	12.53		1515216		
10-24 NC	L.H. Hand Tap	H3	4	42.91	41.57	40.91	25.05	14.00	11.59	1515229	1515230	1515231	72 hours
	Hand tap	H5	4	85.89	56.62	40.91	25.05	14.00	11.59	1515235	1515236	1515237	
	Spiral Point	H5	2	86.84	57.51	41.98	26.25	15.06	12.53		1515234		
	+0.003 Hand Tap	H7	4	35.17	26.38	17.59	13.19	9.43	7.87	1515241	1515242	1515243	
	+0.005 Hand Tap	H11	4	35.17	26.38	17.59	13.19	9.43	7.87	1515247	1515248	1515249	
	+0.005 Spiral Point	H11	2	38.69	29.01	19.34	14.51	9.90	8.26		1515246		
10-28 NS	Hand Tap	H3	4	85.89	56.62	40.91	25.05	14.00	11.59	1515265	1515266	1515267	72 hours
10-30 NS	Hand Tap	H3	4	85.89	56.62	40.91	25.05	14.00	11.59	1515271	1515272	1515273	

- Prices shown for tools in table above are for Bright (uncoated / untreated) tools ONLY
- Additional Charge for Surface Treatments (Bronze Oxide, Steam Oxide & Nitride) . . . Use (List Price x 1.20) + 1 extra week for delivery
- Additional Charge for Coatings (TiN, TiCN, ZrN, and TiAlN) . . . Use (List Price x 1.35) + 1 extra week for delivery

For FlashTap information call:
800.639.1776



Semi-Special Threading Program

Machine Screw & Fractional

USD

SIZE	DESCRIPTION	O.D. TOL	# FLT	QUANTITY/LIST PRICE						TAPER EDP#	PLUG EDP#	BOTTOM EDP#	SHIPPING IN 24-48 HOURS (except where noted)
				1	2	3	6	12	24				
10-32 NF	L.H. Hand Tap	H3	4	42.91	41.57	40.91	25.05	14.00	11.59	1515277	1515278	1515279	72 hours
	Hand Tap	H4	4	89.34	56.85	40.91	25.05	14.26	11.59		1517898	1517899	
	Hand Tap	H5	4	85.89	56.62	40.91	25.05	14.00	11.59	1515289	1515290	1515291	
	Spiral Point	H4	2	86.84	57.51	41.98	26.25	15.06	12.53		1515282		
	Spiral Point	H5	2	86.84	57.51	41.98	26.25	15.06	12.53		1515288		
	+ .003 Hand Tap	H7	4	35.17	26.38	17.59	13.19	9.43	7.87	1515295	1515296	1515297	
	+ .005 Hand Tap	H11	4	35.17	26.38	17.59	13.19	9.43	7.87	1515301	1515302	1515303	
+ .005 Spiral Point	H11	2	38.69	29.01	19.34	14.51	9.90	8.26		1515300		72 hours	
10-36 NS	Hand Tap	H2	4	85.89	56.62	40.91	25.05	14.00	11.59	1515319	1515320	1515321	
10-40 NS	Hand Tap	H2	4	85.89	56.62	40.91	25.05	14.00	11.59	1515325	1515326	1515327	
	Spiral Point	H2	2	86.84	57.51	41.98	26.25	15.06	12.53		1515324		
10-48 NS	Hand Tap	H2	4	85.89	56.62	40.91	25.05	14.00	11.59	1515331	1515332	1515333	
	Hand Tap	H5	4	85.89	56.62	40.91	25.05	14.00	11.59	1517779	1517780	1517781	
10-56 NS	Hand Tap	H2	4	85.89	56.62	40.91	25.05	14.00	11.59	1515337	1515338	1515339	
10-64 NS	Hand Tap	H2	4	85.89	56.62	40.91	25.05	14.00	11.59	1515343	1515344	1515345	
.210-36 NS	Hand Tap	H3	4	98.88	65.04	45.18	28.78	15.73	12.40	1517645	1517646	1517647	
	Hand Tap	H4	4	98.88	65.04	45.18	28.78	15.73	12.40		1517901	1517902	
12-24 NC	L.H. Hand Tap	H3	4	44.38	44.10	43.44	28.78	15.73	12.40	1515373	1515374	1515375	
12-28 NF	L.H. Hand Tap	H3	4	44.38	44.10	43.44	28.78	15.73	12.40	1515379	1515380	1515381	
12-32 NEF	Hand Tap	H3	4	27.23	23.04	18.69	10.92	7.83	7.19	1515385	1515386	1515387	
	Spiral Point	H3	2	45.70	45.04	44.10	29.46	16.52	13.06		1515384		
12-36 NS	Hand Tap	H2	4	87.65	58.02	43.44	28.78	15.73	12.40	1515391	1515392	1515393	
14-20 NS	Hand Tap	H3	4	84.94	63.57	45.30	30.51	17.59	13.73	1515397	1515398	1515399	
14-24 NS	Hand Tap	H3	4	84.94	63.57	45.30	30.51	17.59	13.73	1515403	1515404	1515405	
1/16-27 PIPE TAP NPT, NPTF	L.H. Taper (NPT)		4	85.02	61.03	42.25	28.92	20.63	17.72		1515407		72 hours
	L.H. Taper (NPTF)		4	85.02	61.03	42.25	28.92	20.63	17.72		1515407F		
	Int. Thd. Taper		5	101.68	71.02	49.44	33.45	23.45	22.79		1517677		
1/8-28 55° MOD WHITWORTH PIPE	BSPT Taper		4	38.24	29.05	26.12	23.85	20.52	20.40		1515434		
	BSPP Parallel		4	38.24	29.05	26.12	23.85	20.52	20.40		1515437		
5/32-32 NS	Hand Tap	H3	4	85.32	56.48	43.58	26.78	15.46	12.13	1517559	1517560	1517561	
3/16-24 NS	Hand Tap	H3	4	85.89	56.62	43.58	26.78	15.46	12.13	1515442	1515443	1515444	
3/16-32 NS	Hand Tap	H3	4	85.89	56.62	43.58	26.78	15.46	12.13	1515448	1515449	1515450	
7/32-32 NS	Hand Tap	H3	4	95.68	65.04	43.58	26.78	15.46	12.13	1517564	1517565	1517566	
1/4-19 55° MOD WHITWORTH PIPE	BSPT Taper		4	39.85	30.51	27.58	25.18	24.26	23.45		1515479		
	BSPP Parallel		4	39.85	30.51	27.58	25.18	24.26	23.45		1515482		
1/4-20 NC	L.H. Hand Tap	H3	4	44.38	44.10	43.44	28.78	15.73	12.40	1515487		1515489	1 week 1 week
	+ .003 Hand Tap	H7	4	87.86	58.67	41.98	26.52	15.58	12.13	1515493	1515494	1515495	
	+ .003 Spiral Point	H7	2	89.40	59.47	43.04	27.58	16.66	13.19		1515492		
	+ .010 Hand Tap	H21	4	88.62	63.70	43.31	28.26	16.66	13.19	1515505	1515506	1515507	
	Double Lead	H3	4	123.00	90.62	62.51	40.51	22.92	17.99	1515511	1515512	1515513	
1/4-24 NS	52° Spiral Flute	H5	3	87.95	61.30	53.44	38.91	23.05	19.46		1517766	1517767	
	Hand Tap	H3	4	35.04	26.12	22.00	17.59	11.05	10.53	1515535	1515536	1515537	
1/4-27 NS	Spiral Point	H3	2	36.92	27.19	23.19	18.80	13.75	11.86		1515534		
	Hand Tap	H3	4	35.04	26.12	22.00	17.59	11.05	10.53	1515541	1515542	1515543	
1/4-28 NF	L.H. Hand Tap	H3	4	35.04	26.12	22.00	17.59	11.05	10.53	1515547		1515549	72 hours
	Hand Tap	H5	4	87.55	61.43	41.57	26.52	15.58	12.13	1515553	1515554	1515555	
	Spiral Point	H5	2	89.40	62.63	42.78	27.58	16.66	13.19		1515552		
	+ .003 Hand Tap	H7	4	87.86	61.43	41.57	26.52	15.58	12.13	1515559	1515560	1515561	
	+ .003 Spiral Point	H7	2	89.40	62.63	42.78	27.58	16.66	13.19		1515558		
	+ .005 Hand Tap	H11	4	35.04	26.12	22.00	17.59	11.05	10.53		1515566	1515567	
	+ .005 Spiral Point	H11	2	38.54	28.73	24.19	19.34	12.15	11.58		1515564		
Double Lead	H3	4	123.00	90.62	62.51	40.51	22.92	17.99	1515571	1515572	1515573		
1/4-32 NEF	Hand Tap	H3	4	19.31	15.65	12.07	9.72	6.67	6.52	1515583	1515584	1515585	
	L.H. Hand Tap	H3	4	86.09	63.21	54.90	35.32	19.46	15.86	1517783	1517784	1517785	
	Hand Tap	H5	4	38.78	28.67	18.73	13.10	8.66	8.26	1515589	1515590	1515591	
	Spiral Point	H3	2	61.23	45.79	30.35	19.02	12.07	11.86		1515588		

- Prices shown for tools in table above are for Bright (uncoated / untreated) tools ONLY
- Additional Charge for Surface Treatments (Bronze Oxide, Steam Oxide & Nitride) . . . Use (List Price x 1.20) + 1 extra week for delivery
- Additional Charge for Coatings (TiN, TiCN, ZrN, and TiAlN) . . . Use (List Price x 1.35) + 1 extra week for delivery



For FlashTap information call:
800.639.1776

Semi-Special Threading Program

Fractional (con't)

USD

SIZE	DESCRIPTION	O.D. TOL	# FLT	1	2	3	6	12	24	TAPER EDP#	PLUG EDP#	BOTTOM EDP#	SHIPPING IN 24-48 HOURS (except where noted)
1/4-36 NS	Hand Tap	H2	4	35.04	26.12	22.00	17.59	11.05	10.53	1515595	1515596	1515597	
	Spiral Point	H2	2	36.92	27.19	23.19	18.80	13.75	11.86		1515594		
	Hand Tap	H3	4	86.35	65.56	50.92	32.85	18.07	14.78	1517758	1517759	1517760	
	Spiral Point	H3	2	87.55	66.64	45.98	28.92	17.32	13.46		1517572		
1/4-40 NS	Hand Tap	H2	4	35.04	26.12	22.00	17.59	11.05	10.53	1515601	1515602	1515603	
	Spiral Point	H2	3	36.92	27.19	23.19	18.80	13.75	11.86		1517573		
	Hand Tap	H3	4	88.82	65.56	44.77	27.72	16.12	12.40		1515608	1515609	
1/4-48 NS	Hand Tap	H2	4	35.04	26.12	22.00	17.59	11.05	10.53	1515613	1515614	1515615	
1/4-56 NS	Hand Tap	H2	4	35.04	26.12	22.00	17.59	11.05	10.53	1515619	1515620	1515621	
1/4-80 NS	Hand Tap	H2	4	101.91	69.69	47.57	30.79	19.32	15.46	1515637	1515638	1515639	
9/32-32	Hand Tap	H3	4	108.21	77.55	53.44	35.72	19.32	15.46	1517588	1517589	1517590	
5/16-18 NC	L.H. Hand Tap	H3	4	38.40	28.80	19.20	14.40	10.55	8.79	1515643		1515645	
	+0.003 Hand Tap	H7	4	89.40	66.76	45.70	28.26	16.12	12.65	1515649	1515650	1515651	
	+0.003 Spiral Point	H7	2	108.21	77.55	53.44	35.72	21.06	17.06	1515661	1515662	1515663	
	+0.010 Hand Tap	H21	4	90.28	67.97	46.78	29.46	17.46	13.85		1515648		
	Double Lead	H3	4	139.59	99.57	66.42	45.58	25.98	21.07	1515667	1515668	1515669	
5/16-20 NS	Hand Tap	H3	4	32.78	28.26	27.32	19.32	12.93	11.59	1515683	1515684	1515685	
5/16-24 NF	L.H. Hand Tap	H3	4	38.40	28.80	19.20	14.40	10.55	8.79	1515695		1515697	
	Hand Tap	H5	4	108.21	77.55	53.44	35.72	21.06	17.06	1517649	1517650	1517651	
	Spiral Point	H5	2	109.54	78.89	54.51	37.04	22.25	18.12		1517737		
	Hand Tap	H6	4	108.21	77.55	53.44	35.72	21.06	17.06	1517706	1517707	1517708	
	+0.005 Hand Tap	H11	4	35.04	26.12	22.00	17.59	11.05	10.53	1515707	1515708	1515709	72 hours
	+0.005 Spiral Point	H11	2	38.54	28.73	24.19	19.34	12.15	11.58		1515706		
5/16-27 NS	Hand Tap	H3	4	32.78	28.26	27.32	19.32	12.93	11.59	1515718	1515719	1515720	
5/16-28 NS	Hand Tap	H3	4	32.78	28.26	27.32	19.32	12.93	11.59	1515724	1515725	1515726	
5/16-32 NEF	Hand Tap	H3	4	20.12	16.46	12.88	10.13	7.46	6.80	1515729	1515730	1515731	
	Hand Tap	H5	4	39.57	23.19	19.39	13.54	9.86	8.93	1515734	1515735	1515736	
	Spiral Point	H3	2	100.81	74.77	48.72	33.65	19.53	15.95		1515728		
5/16-40 NS	Hand Tap	H2	4	32.78	28.26	27.32	19.32	12.93	11.59	1515739	1515740	1515741	
11/32-32 NS	Hand Tap	H3	4	99.28	75.43	52.91	35.19	19.32	15.73	1515749	1515750	1515751	
3/8-16 NC	L.H. Hand Tap	H3	4	38.40	28.80	19.20	12.40	11.46	11.46	1515755		1515757	
	Spiral Point	H3	2	46.61	46.02	45.28	31.24	19.32	15.73		1517738		
	+0.003 Hand Tap	H7	4	93.81	71.83	50.64	32.91	18.52	15.06	1515765	1515766	1515767	
	+0.003 Spiral Point	H7	3	95.02	73.16	51.97	34.25	19.86	16.12		1515764		
	+0.010 Hand Tap	H21	4	93.81	71.83	50.64	32.91	18.52	15.06	1515775	1515776	1515777	
Double Lead	H3	4	124.88	92.68	63.02	43.71	24.26	19.32	1515780	1515781	1515782	1 week	
3/8-18 NS	Hand Tap	H3	4	48.77	34.68	29.05	21.59	14.39	13.46	1515805	1515806	1515807	
3/8-19 55° MOD WHITWORTH PIPE	BSPT Taper		4	42.97	40.11	37.24	34.38	31.52	28.65		1515830		
	BSPP Parallel		4	42.97	40.11	37.24	34.38	31.52	28.65		1515833		
3/8-20 NS	Hand Tap	H3	4	48.77	34.68	29.05	21.59	14.39	13.46	1515837	1515838	1515839	
3/8-24 NF	L.H. Hand Tap	H3	4	38.40	28.80	19.20	12.40	11.46	11.46	1515842		1515844	
	30° Spiral Flute	H5	3	91.95	65.44	57.04	44.25	26.66	23.05		1517724	1517725	
	Hand Tap	H5	4	93.81	71.83	50.64	32.91	18.52	15.06	1515847	1515848	1515849	
	Spiral Point	H5	3	95.02	73.16	51.97	34.25	19.86	16.12		1515846		
	+0.003 Hand Tap	H7	4	93.81	71.83	50.64	32.91	18.52	15.06	1515852	1515853	1515854	
	+0.003 Spiral Point	H7	3	95.02	73.16	51.97	34.25	19.86	16.12		1515851		
	+0.005 Hand Tap	H11	4	35.04	26.12	22.00	17.59	11.05	10.53	1515857	1515858	1515859	72 hours
	+0.005 Spiral Point	H11	3	38.54	28.73	24.19	19.34	12.15	11.58		1515856		1 week
3/8-27 NS	Hand Tap	H3	4	48.77	34.68	29.05	21.59	14.39	13.46	1515867	1515868	1515869	
3/8-28 NS	Hand Tap	H3	4	48.77	34.68	29.05	21.59	14.39	13.46	1515872	1515873	1515874	
3/8-32 NEF	Hand Tap	H3	4	21.29	17.70	14.05	11.46	8.26	7.46	1515877	1515878	1515879	
	Hand Tap	H5	4	42.00	31.46	20.92	14.71	11.20	10.39	1515882	1515883	1515884	
	Spiral Point	H3	3	91.52	62.84	44.48	29.49	17.05	13.83		1515876		
3/8-40 NS	Hand Tap	H2	4	48.77	34.68	29.05	21.59	14.39	13.46	1515887	1515888	1515889	
	Hand Tap	H3	4	89.03	68.09	47.44	31.58	17.86	14.39		1517615	1517616	

- Prices shown for tools in table above are for Bright (uncoated / untreated) tools ONLY
- Additional Charge for Surface Treatments (Bronze Oxide, Steam Oxide & Nitride) . . . Use (List Price x 1.20) + 1 extra week for delivery
- Additional Charge for Coatings (TiN, TiCN, ZrN, and TiAlN) . . . Use (List Price x 1.35) + 1 extra week for delivery

For FlashTap information call:
800.639.1776



Semi-Special Threading Program

Fractional (con't)

\$USD

SIZE	DESCRIPTION	O.D. TOL	# FLT	1	2	3	6	12	24	TAPER EDP#	PLUG EDP#	BOTTOM EDP#	SHIPPING IN 24-48 HOURS (except where noted)
3/8-48 NS	Hand Tap	H2	4	94.37	68.09	47.44	31.58	17.86	14.39	1515892	1515893	1515894	
7/16-14 NC	L.H. Hand Tap	H3	4	38.40	28.80	19.20	17.86	16.78	16.78	1515902		1515904	
	+ .010 Hand Tap	H21	4	92.68	72.23	50.37	35.32	21.46	19.20	1515912	1515913	1515914	1 week
7/16-16 NS	Hand Tap	H3	4	59.31	41.70	34.78	24.12	17.06	16.78	1515937	1515938	1515939	
7/16-18 NS	Hand Tap	H3	4	59.31	41.70	34.78	24.12	17.06	16.78	1515942	1515943	1515944	
7/16-20 NF	L.H. Hand Tap	H3	4	59.31	41.70	34.78	24.12	16.78	16.78	1515947		1515949	
	Hand Tap	H6	4	92.68	72.23	50.37	35.32	21.46	17.18	1517740	1517741	1517742	
	+ .005 Hand Tap	H11	4	93.81	71.83	50.64	32.91	21.26	16.78	1515962	1515963	1515964	
	+ .005 Spiral Point	H11	3	95.02	73.16	51.97	34.25	19.82	17.59		1515961		72 hours
7/16-24 NS	Hand Tap	H3	4	59.31	41.70	34.78	24.12	17.06	16.78	1515977	1515978	1515979	
	Hand Tap	H5	4	90.71	72.23	50.37	35.32	21.46	17.18	1515982	1515983	1515984	
7/16-27 NS	Hand Tap	H3	4	59.31	41.70	34.78	24.12	17.06	16.78	1515987	1515988	1515989	
7/16-28 NEF	Hand Tap	H3	4	25.72	23.45	21.19	17.99	17.06	16.78	1515992	1515993	1515994	72 hours
	Hand Tap	H5	4	42.66	32.19	21.73	17.99	17.06	16.78	1515997	1515998	1515999	1 week
7/16-32 NS	Hand Tap	H3	4	59.31	41.70	34.78	24.12	17.06	16.78	1516002	1516003	1516004	
7/16-40 NS	Hand Tap	H2	4	59.31	41.70	34.78	24.12	17.06	16.78	1516007	1516008	1516009	
15/32-32 NS	Hand Tap	H3	4	99.35	74.35	53.97	37.84	23.85	19.20	1516012	1516013	1516014	
	Spiral Pt	H3	3	101.17	76.23	55.70	39.85	25.72	21.06		1516011		
1/2-12 NS	Hand Tap	H3	4	62.76	44.18	36.38	26.78	19.32	19.20	1516027	1516028	1516029	
1/2-13 NC	L.H. Hand Tap	H3	4	59.31	41.70	34.78	24.12	19.20	19.20	1516037		1516039	
	+ .003 Hand Tap	H7	4	68.90	54.51	39.97	28.38	19.32	19.20		1516043	1516044	
	+ .010 Hand Tap	H21	4	107.01	76.63	55.44	37.84	23.85	19.20	1516052	1516053	1516054	
	Double Lead	H3	4	136.06	102.62	74.22	52.50	37.60	32.51	1516057	1516058	1516059	
1/2-14 NS	Hand Tap	H3	4	62.76	44.18	36.38	26.78	19.32	19.20	1516114	1516115	1516116	
1/2-14 55° MOD	BSPT		4	64.92	60.28	55.65	46.37	46.37	46.37		1516107		1 week
WHITWORTH PIPE	BSPP Parallel		4	64.92	60.28	55.65	46.37	46.37	46.37		1516110		
1/2-16 NS	Hand Tap	H3	4	62.76	44.18	36.38	26.78	19.32	19.20	1516119	1516120	1516121	
1/2-18 NS	Hand Tap	H3	4	62.76	44.18	36.38	26.78	19.32	19.20		1516125	1516126	
1/2-20 NF	L.H. Hand Tap	H3	4	59.31	41.70	34.78	24.12	19.20	19.20	1516129	1516130	1516131	
	Hand Tap	H5	4	107.01	76.63	55.44	37.84	23.85	19.20			1517634	
	+ .003 Hand Tap	H7	4	70.76	55.84	41.05	28.92	20.40	19.20		1516135	1516136	
	+ .005 Hand Tap	H11	4	70.76	55.84	41.05	28.92	20.40	19.20	1516139	1516140	1516141	
	+ .005 Spiral Point	H11	3	95.02	73.16	51.97	34.25	21.06	21.06		1516138		72 hours
1/2-24 NS	Hand Tap	H3	4	62.76	44.18	36.38	26.78	19.32	19.20	1516154	1516155	1516156	
1/2-27 NS	Hand Tap	H3	4	62.76	44.18	36.38	26.78	19.32	19.20	1516159	1516160	1516161	
1/2-28 NEF	Hand Tap	H3	4	27.58	25.45	20.92	15.33	12.25	12.13	1516164	1516165	1516166	
	Hand Tap	H5	4	44.18	26.66	23.27	19.59	17.59	17.32	1516169	1516170	1516171	
	Spiral Point	H3	3	95.84	67.16	50.11	34.60	22.16	17.92		1516163		
1/2-32 NS	Hand Tap	H3	6	62.76	44.18	36.38	26.78	19.32	19.20	1516174	1516175	1516176	
1/2-40 NS	Hand Tap	H2	6	62.76	44.18	36.38	26.78	19.32	19.20	1516179	1516180	1516181	
9/16-12 NC	L.H. Hand Tap	H3	4	29.85	29.49	29.04	27.73	26.40	24.39	1516189		1516191	
	Spiral Point	H3	3	33.80	33.28	32.70	31.46	29.77	26.92		1518331		
9/16-16 NS	Hand Tap	H3	4	69.69	49.16	39.85	28.52	24.65	24.39	1516199	1516200	1516201	
9/16-18 NF	L.H. Hand Tap	H3	4	59.31	41.70	34.78	27.73	26.40	24.39	1516204		1516206	
	Hand Tap	H5	4	98.49	71.17	65.34	44.85	26.92	24.39			1517769	
	Spiral Point	H3	3	33.80	33.28	32.70	31.46	29.77	26.92		1518337		
	Spiral Point	H5	3	101.02	73.69	55.70	43.04	28.38	26.78		1517655		
	+ .005 Hand Tap	H11	4	98.49	71.17	53.16	40.51	25.99	24.39	1516214	1516215	1516216	
	+ .005 Spiral Point	H11	3	101.02	73.69	55.70	43.04	28.38	26.78		1516213		72 hours
9/16-20 NS	Hand Tap	H3	4	69.69	49.16	39.85	28.52	24.65	24.39	1516224	1516225	1516226	
9/16-24NEF	Hand Tap	H3	4	30.38	26.66	22.79	17.18	15.06	14.67	1516229	1516230	1516231	
	Hand Tap	H5	4	46.16	36.57	27.14	20.18	16.78	15.58	1516234	1516235	1516236	
9/16-27 NS	Hand Tap	H3	6	69.69	49.16	39.85	28.52	24.65	24.39	1516239	1516240	1516241	
9/16-32 NS	Hand Tap	H3	6	69.69	49.16	39.85	28.52	24.65	24.39	1516244	1516245	1516246	

- Prices shown for tools in table above are for Bright (uncoated / untreated) tools ONLY
- Additional Charge for Surface Treatments (Bronze Oxide, Steam Oxide & Nitride) . . . Use (List Price x 1.20) + 1 extra week for delivery
- Additional Charge for Coatings (TiN, TiCN, ZrN, and TiAlN) . . . Use (List Price x 1.35) + 1 extra week for delivery



For FlashTap information call:
800.639.1776

Semi-Special Threading Program

Fractional (con't)

\$USD

SIZE	DESCRIPTION	O.D. TOL	# FLT	QUANTITY/LIST PRICE						TAPER EDP#	PLUG EDP#	BOTTOM EDP#	SHIPPING IN 24-48 HOURS (except where noted)	
				1	2	3	6	12	24					
5/8-10 NS	Hand Tap	H3	4	100.45	71.70	53.11	41.48	26.77	23.27	1516259	1516260	1516261		
5/8-11 NC	L.H. Hand Tap	H3	4	38.05	37.46	36.88	35.26	33.51	29.63	1516269		1516271		
	30° Spiral Flute	H3	4	120.06	93.15	70.50	54.76	38.12	33.99		1516284	1516285		
	52° Spiral Flute	H3	4	120.06	93.15	70.50	54.76	38.12	33.99		1517717	1517718		
	+0.10 Hand Tap	H21	4	110.20	77.82	56.90	43.98	27.46	25.59		1516279	1516280	1516281	
5/8-12 NS	Hand Tap	H3	4	74.89	53.11	45.18	34.38	25.59	24.93	1516319	1516320	1516321		
5/8-16 NS	Hand Tap	H3	4	74.89	53.11	45.18	34.38	25.59	24.93	1516324	1516325	1516326		
5/8-18 NF	L.H. Hand Tap	H3	4	38.05	37.46	36.88	35.26	33.51	29.63	1516329		1516331		
	30° Spiral Flute	H3	4	120.06	93.15	70.50	54.76	38.12	33.99		1516339	1516340		
	52° Spiral Flute	H3	4	120.06	93.15	70.50	54.76	38.12	33.99		1517727	1517728		
	Hand Tap	H8	4	110.20	77.82	56.90	43.98	27.46	24.93		1517904	1517905		
	Spiral Point	H3	3	112.87	80.62	59.71	46.64	30.25	27.46		1518353	1518354		
	Spiral Point	H5	3	112.87	80.62	59.71	46.64	32.19	28.83		1517683			
	+0.03 Hand Tap	H7	4	110.20	77.82	56.90	43.98	29.63	26.26		1517680	1517681	1517682	
	+0.05 Hand Tap	H11	4	39.30	38.55	37.75	36.94	33.59	29.63		1516334	1516335	1516336	
5/8-20 NS	Hand Tap	H3	4	74.89	53.11	45.18	34.38	25.59	24.93	1516348	1516349	1516350		
5/8-24 NEF	Hand Tap	H3	6	34.38	31.72	29.18	21.06	17.32	16.27	1516353	1516354	1516355		
	Hand Tap	H5	6	49.61	39.15	32.39	24.20	19.41	18.19	1516358	1516359	1516360		
5/8-27 NS	Hand Tap	H3	6	74.89	53.11	45.18	34.38	25.59	24.93	1516363	1516364	1516365		
5/8-28 NS	Hand Tap	H3	6	74.89	53.11	45.18	34.38	25.59	24.93	1516368	1516369	1516370		
5/8-32 NS	Hand Tap	H3	6	74.89	53.11	45.18	34.38	25.59	24.93	1516373	1516374	1516375		
11/16-11 NS	L.H. Hand Tap	H3	4	45.45	45.45	41.17	41.17	41.17	34.50	1516383	1516384	1516385		
11/16-16 NS	L.H. Hand Tap	H3	4	45.45	45.45	41.17	41.17	41.17	34.50	1516388	1516389	1516390		
11/16-18 NS	L.H. Hand Tap	H3	4	120.06	89.82	66.89	51.17	35.19	29.85	1517575	1517576	1517577		
	Hand Tap	H3	4	79.03	57.80	51.17	38.24	29.98	28.38	1516393	1516394	1516395		
11/16-20 NS	Hand Tap	H3	6	79.03	57.80	51.17	38.24	29.98	28.38	1516398	1516399	1516400		
11/16-24 NEF	Hand Tap	H3	6	34.50	30.51	26.92	24.26	24.26	24.26	1516403	1516404	1516405		
	Hand Tap	H5	6	52.31	41.78	34.50	28.92	24.26	24.26	1516408	1516409	1516410		
11/16-28 NS	Hand Tap	H3	6	79.03	57.80	51.17	38.24	29.98	28.38	1516418	1516419	1516420		
11/16-32 NS	Hand Tap	H3	6	79.03	57.80	51.17	38.24	29.98	28.38	1516423	1516424	1516425		
3/4-10 NC	L.H. Hand Tap	H3	4	49.53	48.29	46.37	43.82	42.66	36.14	1516448		1516450		
	30° Spiral Flute	H3	4	137.12	108.21	75.43	58.64	48.51	43.58		1516463	1516464		
	+0.005 Hand Tap	H11	4	39.80	38.63	37.97	37.39	35.70	29.85		1516453	1516454	1516455	
	+0.005 Spiral Pt	H11	3	72.43	57.80	56.69	41.63	36.44	34.90			1516152		
	+0.10 Hand Tap	H21	4	121.53	89.82	68.63	46.53	34.78	32.65		1516458	1516459	1516460	
3/4-12 NS	Hand Tap	H4	4	84.22	64.08	53.70	39.57	32.51	30.38	1516501	1516502	1516503		
3/4-14 55° MOD WHITWORTH PIPE	BSPT Taper		5	72.95	69.78	66.60	63.44	63.44	63.44		1516526			
	BSP Parallel		5	72.95	69.78	66.60	63.44	63.44	63.44		1516529			
3/4-16 NF	L.H. Hand Tap	H3	4	49.53	48.29	46.37	43.82	42.66	36.14	1516533	1516534	1516535		
	L.H. Hand Tap	H5	4	115.27	94.81	83.16	65.44	45.70	40.77		1517787	1517788	1517789	
	30° Spiral Flute Taper	H3	4	137.12	108.21	90.34	66.64	48.51	43.58			1516543	1516544	
	Spiral Point	H5	3	77.96	62.76	61.03	44.77	39.18	37.58			1517692		
	+0.003 Hand Tap	H7	4	117.13	86.11	68.63	54.10	37.58	33.18		1517636	1517637	1517638	
	+0.005 Hand Tap	H11	4	39.06	38.48	37.89	37.39	35.70	31.01		1516538	1516539	1516540	
	Hand Tap	H8	4	117.13	86.11	68.63	54.10	37.58	33.18		1517744	1517745	1517746	
3/4-18 NS	Hand Tap	H3	4	84.22	64.08	53.70	38.78	32.51	30.38	1516547	1516548	1516549		
3/4-20 NEF	L.H. Hand Tap	H3	6	115.27	89.82	83.16	65.44	45.70	40.77	1517662	1517663	1517664		
	Hand Tap	H3	6	36.92	33.31	30.25	25.59	25.59	25.59	1516552	1516553	1516554		
	Hand Tap	H5	6	55.82	45.00	34.09	29.04	25.59	25.59	1516557	1516558	1516559		
3/4-24 NS	Hand Tap	H3	6	84.22	64.08	53.70	38.78	32.51	30.38	1516562	1516563	1516564		
3/4-27 NS	Hand Tap	H3	6	84.22	64.08	53.70	38.78	32.51	30.38	1516567	1516568	1516569		
3/4-32 NS	Hand Tap	H3	6	84.22	64.08	53.70	38.78	32.51	30.38	1516572	1516573	1516574		
3/4-40 NS	Hand Tap	H3	6	113.47	83.39	68.63	54.10	37.58	33.18	1516577	1516578	1516579		
13/16-10 NS	Hand Tap	H4	4	88.08	65.11	58.10	45.04	35.58	34.11	1516596	1516597	1516598		

- Prices shown for tools in table above are for Bright (uncoated / untreated) tools ONLY
- Additional Charge for Surface Treatments (Bronze Oxide, Steam Oxide & Nitride) . . . Use (List Price x 1.20) + 1 extra week for delivery
- Additional Charge for Coatings (TiN, TiCN, ZrN, and TiAlN) . . . Use (List Price x 1.35) + 1 extra week for delivery

For FlashTap information call:
800.639.1776



Semi-Special Threading Program

Fractional (con't)

\$USD

SIZE	DESCRIPTION	O.D. TOL	# FLT	1	2	3	6	12	24	TAPER EDP#	PLUG EDP#	BOTTOM EDP#	SHIPPING IN 24-48 HOURS (except where noted)
13/16-12 NS	Hand Tap	H4	4	88.08	65.11	58.10	45.04	35.58	34.11	1516601	1516602	1516603	
13/16-16 NS	Hand Tap	H3	4	88.08	65.11	58.10	45.04	35.58	34.11	1516606	1516607	1516608	
13/16-18 NS	Hand Tap	H3	4	88.08	65.11	58.10	45.04	35.58	34.11	1516611	1516612	1516613	
13/16-20 NEF	Hand Tap	H3	6	43.85	41.17	37.98	30.79	30.79	30.79	1516616	1516617	1516618	
	Hand Tap	H5	6	67.83	56.38	41.98	37.98	30.79	30.79	1516621	1516622	1516623	
13/16-24 NS	Hand Tap	H3	6	88.08	65.11	58.10	45.04	35.58	34.11	1516626	1516627	1516628	
7/8-9 NC	L.H. Hand Tap	H4	4	67.16	65.34	62.48	59.41	50.92	47.71	1516641	1516642	1516643	
	+005 Hand Tap	H11	4	53.99	52.83	51.65	50.77	45.00	40.31	1516651	1516652	1516653	
7/8-10 NS	Hand Tap	H4	4	93.42	70.95	65.04	54.24	42.78	41.31	1516660	1516661	1516662	
7/8-12 NS	Hand Tap	H4	4	93.42	70.95	65.04	54.24	42.78	41.31	1516665	1516666	1516667	
7/8-14 NF	L.H. Hand Tap	H4	4	67.45	65.34	62.55	59.41	50.92	47.71	1516670	1516671	1516672	
	Hand Tap	H5	4	130.46	97.80	79.69	63.44	56.78	52.91	1517748	1517749	1517750	
	Hand Tap	H6	4	130.46	97.80	79.69	63.44	56.78	52.91	1517685	1517686	1517687	
	+005 Hand Tap	H11	4	53.99	52.83	51.65	50.77	45.00	40.31	1516675	1516676	1516677	
7/8-16 NS	Hand Tap	H3	4	93.42	70.95	65.04	54.24	42.78	41.31	1516680	1516681	1516682	
7/8-18 NS	Hand Tap	H3	4	93.42	70.95	65.04	54.24	42.78	41.31	1516685	1516686	1516687	
7/8-20 NEF	Hand Tap	H3	6	41.12	39.97	39.97	34.11	30.79	29.98	1516690	1516691	1516692	
	Hand Tap	H5	6	63.57	52.74	41.98	36.92	33.45	31.85	1516695	1516696	1516697	
7/8-24 NS	Hand Tap	H3	6	130.60	97.95	77.55	64.63	47.57	41.31	1516700	1516701	1516702	
7/8-27 NS	Hand Tap	H3	6	130.60	97.95	77.55	64.63	47.57	41.31	1516705	1516706	1516707	
7/8-32 NS	Hand Tap	H3	6	130.60	97.95	77.55	64.63	47.57	41.31	1516710	1516711	1516712	
15/16-12 NS	Hand Tap	H4	4	97.01	73.59	68.63	57.70	43.58	42.37	1516715	1516716	1516717	
15/16-14 NS	Hand Tap	H4	4	97.01	73.59	68.63	57.70	43.58	42.37	1516720	1516721	1516722	
15/16-16 NS	Hand Tap	H3	6	97.01	73.59	68.63	57.70	43.58	42.37	1516725	1516726	1516727	
15/16-18 NS	Hand Tap	H3	6	97.01	73.59	68.63	57.70	43.58	42.37	1516730	1516731	1516732	
15/16-20 NEF	Hand Tap	H3	6	50.37	48.11	46.37	38.91	34.92	32.65	1516735	1516736	1516737	
	Hand Tap	H5	6	65.11	54.28	44.10	39.05	36.38	33.99	1516740	1516741	1516742	
15/16-32 NS	Hand Tap	H3	6	133.27	105.41	81.02	69.16	50.77	48.11	1516755	1516756	1516757	
1"-8 NC	L.H. Hand Tap	H4	4	90.28	86.62	82.67	78.72	72.36	62.36	1516774	1516775	1516776	
	+005 Hand Tap	H11	4	73.91	71.85	69.80	66.50	55.83	49.61	1516784	1516785	1516786	
	+010 Hand Tap	H21	4	149.11	121.13	119.01	100.34	75.01	67.16		1517732	1517733	
	52° Spiral Flute	H4	4	166.83	139.92	116.34	104.22	82.09	73.82		1517791	1517792	
1"-10 NS	Hand Tap	H4	4	110.08	94.08	80.23	60.77	46.51	43.19	1516808	1516809	1516810	
1"-11 55° MOD WHITWORTH PIPE	BSPT Taper	H4	5	115.62	105.98	96.35	96.35	96.35	96.35		1516812		
	BSP Parallel	H4	5	115.62	105.98	96.35	96.35	96.35	96.35		1516815		
1"-12 NF	L.H. Hand Tap	H4	4	90.28	86.62	82.67	78.72	72.36	62.36	1516828	1516829	1516830	
	Hand Tap	H6	4	140.99	108.21	85.29	76.63	56.90	51.44	1516833	1516834	1516835	
	+005 Hand Tap	H11	4	73.90	71.84	69.79	66.50	55.82	49.61	1516838	1516839	1516840	
1"-14 NS	L.H. Hand Tap	H4	4	90.28	86.62	82.67	78.72	72.36	62.36	1516843	1516844	1516845	
	Hand Tap	H6	4	140.99	108.21	85.29	76.63	56.90	51.44	1516848	1516849	1516850	
	+005 Hand Tap	H11	4	73.90	71.84	69.79	66.50	55.82	49.61	1516853	1516854	1516855	
1"-16 NS	L.H. Hand Tap	H3	6	110.08	94.81	80.23	60.37	46.78	43.04	1516949	1516950	1516951	
	Hand Tap	H3	6	110.08	94.81	80.23	60.37	46.78	43.04	1516858	1516859	1516860	
1"-18 NS	Hand Tap	H3	6	110.08	94.81	80.23	60.37	46.78	43.04	1516863	1516864	1516865	
1"-20 NEF	L.H. Hand Tap	H3	6	134.90	101.99	81.06	69.79	52.31	47.34	1517579	1517580	1517581	
	Hand Tap	H3	6	57.29	53.70	50.11	46.37	40.51	38.52	1516868	1516869	1516870	
	Hand Tap	H5	6	84.61	70.50	58.10	52.91	44.10	42.37	1516873	1516874	1516875	
1"-24 NS	Hand Tap	H3	6	110.08	94.81	80.23	60.37	46.78	43.04	1516878	1516879	1516880	
1"-27 NS	Hand Tap	H3	6	110.08	94.81	80.23	60.37	46.78	43.04	1516883	1516884	1516885	
1"-32 NS	Hand Tap	H3	6	110.08	94.81	80.23	60.37	46.78	43.04	1516888	1516889	1516890	
1-1/16-12 NS	Hand Tap	H4	4	128.74	110.20	96.08	82.22	72.36	71.17	1517713	1517714	1517715	
	Hand Tap	H5	4	63.30	63.30	63.30	59.97	59.97	56.04	1516892	1516893	1516894	
	Hand Tap	H7	4	63.30	63.30	63.30	59.97	59.97	56.04	1516896	1516897	1516898	
1-1/16-14 NS	Hand Tap	H5	6	116.21	99.20	86.35	59.97	59.97	54.10	1516900	1516901	1516902	

- Prices shown for tools in table above are for Bright (uncoated / untreated) tools ONLY
- Additional Charge for Surface Treatments (Bronze Oxide, Steam Oxide & Nitride) . . . Use (List Price x 1.20) + 1 extra week for delivery
- Additional Charge for Coatings (TiN, TiCN, ZrN, and TiAlN) . . . Use (List Price x 1.35) + 1 extra week for delivery



For FlashTap information call:
800.639.1776

Semi-Special Threading Program

Fractional (con't)

USD

SIZE	DESCRIPTION	O.D. TOL	# FLT	1	2	3	6	12	24	TAPER EDP#	PLUG EDP#	BOTTOM EDP#	SHIPPING IN 24-48 HOURS (except where noted)
1-1/16-16 NF	Hand Tap	H4	6	116.21	99.20	86.35	59.97	59.97	54.10	1516904	1516905	1516906	
	Hand Tap	H6	6	116.21	99.20	86.35	59.97	59.97	54.10	1516908	1516909	1516910	
1-1/16-18 NF	Hand Tap	H4	6	71.17	69.43	68.24	59.97	59.97	54.10	1516912	1516913	1516914	
	Hand Tap	H6	6	97.55	84.61	71.70	59.97	59.97	54.10	1516916	1516917	1516918	
1-1/16-20 NS	Hand Tap	H4	6	140.99	113.94	93.96	78.89	59.97	54.10	1516920	1516921	1516922	
1-1/16-24 NS	Hand Tap	H4	6	140.99	113.94	93.96	78.89	59.97	54.10	1516924	1516925	1516926	
1-1/8-7 NC	L.H. Hand Tap	H4	4	144.56	130.88	122.83	107.94	85.42	81.68	1516938	1516939	1516940	
1-1/8-8 NS	Hand Tap	H5	4	65.04	65.04	65.04	65.04	65.04	65.04	1516942	1516943	1516944	
1-1/8-10 NS	Hand Tap	H5	4	166.71	129.00	110.87	94.48	72.23	65.04	1516946	1516947	1516948	
1-1/8-12 NF	L.H. Hand Tap	H4	4	144.56	130.88	122.83	107.94	85.42	81.68	1516950	1516951	1516952	
	Hand Tap	H6	4	166.71	129.00	110.87	94.48	72.23	65.04	1516954	1516955	1516956	
	+ .005 Hand Tap	H11	4	166.71	129.00	110.87	94.48	72.23	65.04	1517775	1517776	1517777	
1-1/8-14 NS	Hand Tap	H5	6	149.92	118.47	95.95	80.89	64.10	60.63	1516958	1516959	1516960	
1 1/8-16 NS	Hand Tap	H4	6	60.63	60.63	60.63	60.63	60.63	60.63	1516962	1516963	1516964	
1 1/8-18 NEF	Hand Tap	H4	6	70.23	68.49	66.89	60.63	60.63	60.63	1516966	1516967	1516968	
	Hand Tap	H6	6	95.81	85.55	72.62	65.04	64.10	60.63	1516970	1516971	1516972	
1 1/8-20 NS	Hand Tap	H4	6	86.75	85.55	76.01	65.04	64.10	60.63	1516974	1516975	1516976	
1-1/8-24 NS	Hand Tap	H4	6	151.52	119.40	95.95	81.82	64.10	60.63	1516978	1516979	1516980	
1-1/8-32 NS	Hand Tap	H4	6	151.52	119.40	95.95	81.82	64.10	60.63	1516986	1516987	1516988	
1-3/16-12 NS	Hand Tap	H5	6	94.74	93.96	93.96	88.49	85.42	85.42	1516990	1516991	1516992	
1-3/16-14 NS	Hand Tap	H5	6	166.98	128.06	105.01	89.42	72.62	69.16	1516994	1516995	1516996	
1-3/16-16 NS	Hand Tap	H4	6	147.33	113.24	93.96	88.49	72.62	69.16	1516998	1516999	1517000	
	Hand Tap	H6	6	147.33	113.24	93.96	88.49	72.62	69.16	1517002	1517003	1517004	
1-3/16-18 NEF	Hand Tap	H4	6	85.15	83.28	81.68	77.96	72.62	69.16	1517006	1517007	1517008	
	Hand Tap	H6	6	116.75	102.08	89.42	82.49	72.62	69.16	1517010	1517011	1517012	
1-3/16-20 NS	Hand Tap	H4	6	166.98	128.06	105.01	89.42	72.62	69.16	1517014	1517015	1517016	
1-1/4-7 NC	L.H. Hand Tap	H4	4	165.11	161.16	136.51	121.66	95.40	88.82	1517028	1517029	1517030	
	Hand Tap	H8	4	178.17	151.52	128.46	114.47	88.08	82.76	1517032	1517033	1517034	
	+ .005 Hand Tap	H11	4	178.17	151.52	128.46	114.47	88.08	82.76	1517751	1517752	1517753	
1-1/4-8 NS	Hand Tap	H5	4	77.96	77.96	77.96	77.96	77.96	77.96	1517044	1517045	1517046	
1-1/4-10 NS	Hand Tap	H5	4	178.17	151.52	128.46	114.47	88.08	82.76	1517056	1517057	1517058	
1-1/4-11-55° MOD WHITWORTH PIPE	BSPT Taper		5	146.02	146.02	146.02	146.02	146.02	146.02		1517060		
1-1/4-12 NF	L.H. Hand Tap	H4	6	165.11	161.16	136.51	121.66	95.40	88.82	1517075	1517076	1517077	
	Hand Tap	H6	6	180.30	151.52	128.46	114.47	88.08	82.76	1517079	1517080	1517081	
1-1/4-14 NS	Hand Tap	H5	6	107.94	104.88	94.59	78.89	67.70	65.29	1517083	1517084	1517085	
1-1/4-16 NS	Hand Tap	H4	6	107.94	104.88	94.59	78.89	67.70	65.29	1517087	1517088	1517089	
1-1/4-18 NEF	Hand Tap	H4	6	102.30	84.36	80.89	78.89	67.70	65.29	1517091	1517092	1517093	
	Hand Tap	H6	6	107.94	104.88	87.83	78.89	67.70	65.29	1517095	1517096	1517097	
1-1/4-20 NS	Hand Tap	H4	6	107.94	104.88	91.52	78.89	67.70	65.29	1517099	1517100	1517101	
1-1/4-24 NS	Hand Tap	H4	6	162.05	132.46	109.80	95.68	68.90	66.50	1517103	1517104	1517105	
1-1/4-32 NS	Hand Tap	H4	6	158.98	129.94	107.67	93.81	67.70	65.29	1517107	1517108	1517109	
1-5/16-12 NS	Hand Tap	H5	6	95.60	79.23	79.01	78.79	78.57	78.35	1517111	1517112	1517113	
	Hand Tap	H8	6	97.24	81.56	81.56	78.79	78.57	78.35	1517115	1517116	1517117	
1-5/16-14 NS	Hand Tap	H5	6	153.55	117.86	99.27	85.31	65.11	60.50	1517119	1517120	1517121	
1-5/16-16 NS	Hand Tap	H4	6	118.74	116.34	107.81	96.89	75.01	70.23	1517123	1517124	1517125	
	Hand Tap	H6	6	118.74	116.34	107.81	96.89	75.01	70.23	1517127	1517128	1517129	
1-5/16-18 NEF	Hand Tap	H4	6	99.40	95.41	94.48	93.02	75.01	70.23	1517131	1517132	1517133	
	Hand Tap	H6	6	133.79	116.34	107.81	96.89	75.01	70.23	1517135	1517136	1517137	
1-5/16-20 NS	Hand Tap	H4	6	153.55	117.86	107.81	96.89	75.01	70.23	1517139	1517140	1517141	
1-3/8-6 NC	L.H. Hand Tap	H4	4	205.72	185.82	181.64	161.11	126.86	113.94	1517153	1517154	1517155	
1-3/8-8 NS	Hand Tap	H5	4	114.47	109.27	104.07	104.07	104.07	104.07	1517157	1517158	1517159	
1-3/8-10 NS	Hand Tap	H5	6	186.11	155.10	133.37	116.32	86.84	79.09	1517161	1517162	1517163	
1-3/8-12 NF	L.H. Hand Tap	H4	6	205.72	185.82	181.64	161.11	126.86	113.94	1517165	1517166	1517167	
1-3/8-16 NS	Hand Tap	H4	6	115.27	113.80	106.07	92.61	81.68	75.16	1517169	1517170	1517171	
1-3/8-18 NEF	Hand Tap	H4	6	96.35	95.95	95.41	92.61	81.68	75.16	1517173	1517174	1517175	
	Hand Tap	H6	6	116.32	113.80	106.07	92.61	81.68	75.16	1517177	1517178	1517179	

- Prices shown for tools in table above are for Bright (uncoated / untreated) tools ONLY
- Additional Charge for Surface Treatments (Bronze Oxide, Steam Oxide & Nitride) . . . Use (List Price x 1.20) + 1 extra week for delivery
- Additional Charge for Coatings (TiN, TiCN, ZrN, and TiAlN) . . . Use (List Price x 1.35) + 1 extra week for delivery

For FlashTap information call:
800.639.1776



Semi-Special Threading Program

Fractional (con't)

USD

SIZE	DESCRIPTION	O.D. TOL	# FLT	QUANTITY/LIST PRICE						TAPER EDP#	PLUG EDP#	BOTTOM EDP#	SHIPPING IN 24-48 HOURS (except where noted)
				1	2	3	6	12	24				
1-3/8-20 NS	Hand Tap	H4	6	182.16	144.45	121.53	104.07	83.55	78.63	1517181	1517182	1517183	
1-7/16-18 NEF	Hand Tap	H4	6	110.20	109.80	109.41	104.88	96.08	79.56	1517185	1517186	1517187	
	Hand Tap	H6	6	154.72	140.45	124.73	115.27	96.08	79.56	1517189	1517190	1517191	
1-1/2-6 NC	L.H. Hand Tap	H4	4	239.59	226.87	211.35	199.88	151.52	129.79	1517203	1517204	1517205	
1-1/2-8 NS	Hand Tap	H5	6	112.47	112.47	112.47	112.47	112.47	112.47	1517215	1517216	1517217	
1-1/2-10 NS	Hand Tap	H5	6	225.21	190.82	164.44	153.79	126.73	112.47	1517227	1517228	1517229	
1-1/2-11-55° MOD WHITWORTH PIPE	BSPT Taper		7	191.09	191.09	191.09	191.09	191.09	191.09		1517231		
1-1/2-12 NF	L.H. Hand Tap	H4	6	261.06	255.72	218.14	196.95	151.52	129.79	1517243	1517244	1517245	
	Hand Tap	H6	6	229.88	190.82	165.92	155.24	118.60	106.61	1517247	1517248	1517249	
1-1/2-16 NS	Hand Tap	H4	6	176.04	151.58	129.00	102.21	92.36	91.54	1517251	1517252	1517253	
1-1/2-18 NEF	Hand Tap	H4	6	105.67	104.61	103.28	102.21	92.36	91.54	1517255	1517256	1517257	
	Hand Tap	H6	6	154.18	130.46	129.00	103.88	92.36	91.54	1517259	1517260	1517261	
1-1/2-20 NS	Hand Tap	H4	6	176.04	151.58	129.00	102.21	92.36	91.54	1517263	1517264	1517265	
1-1/2-24 NS	Hand Tap	H4	6	191.76	145.39	129.00	102.35	92.36	91.54	1517267	1517268	1517269	
1-9/16-16 NS	Hand Tap	H5	6	237.60	197.77	167.52	157.78	128.46	122.87	1517271	1517272	1517273	
1-9/16-18 NEF	Hand Tap	H5	6	171.37	167.64	167.52	157.78	128.46	122.87	1517275	1517276	1517277	
1-5/8-5 1/2 NS	Hand Tap	H7	6	234.13	201.19	167.11	162.84	149.11	146.06	1517279	1517280	1517281	
1-5/8-8 NS	Hand Tap	H6	6	156.34	153.49	151.38	151.38	148.05	144.98	1517283	1517284	1517285	
1-5/8-12 NS	Hand Tap	H6	6	114.73	114.73	114.73	114.73	114.73	114.73	1517287	1517288	1517289	
	Hand Tap	H4	6	190.16	140.99	139.12	114.73	114.73	114.73		1517908	1517909	
1-5/8-16 NS	Hand Tap	H5	6	190.16	146.02	139.12	114.73	114.73	114.73	1517291	1517292	1517293	
1-5/8-18 NS	Hand Tap	H5	6	190.16	148.88	139.12	114.73	114.73	114.73	1517295	1517296	1517297	
1-3/4-5 NC	Hand Tap	H7	6	242.67	202.96	176.70	168.84	153.12	149.79	1517299	1517300	1517301	
1-3/4-8 NS	Hand Tap	H6	6	176.70	176.70	176.70	168.84	153.49	151.74	1517303	1517304	1517305	
1-3/4-10 NS	Hand Tap	H6	6	239.48	188.04	172.17	165.64	150.05	146.72	1517307	1517308	1517309	
1-3/4-12 NS	Hand Tap	H6	6	178.37	170.60	161.32	142.66	139.12	139.12	1517311	1517312	1517313	
	Hand Tap	H8	6	209.89	176.57	172.17	165.64	144.04	143.13	1517315	1517316	1517317	
1-3/4-16 NS	Hand Tap	H5	6	209.89	176.57	172.17	143.13	143.13	143.13	1517319	1517320	1517321	
	Hand Tap	H7	6	225.47	188.04	172.17	165.64	150.05	146.72	1517323	1517324	1517325	
1-3/4-18 NS	Hand Tap	H5	6	225.47	188.04	172.17	165.64	150.05	146.72	1517327	1517328	1517329	
1-7/8-5 NS	Hand Tap	H7	6	276.37	246.12	242.41	200.69	194.30	183.76	1517331	1517332	1517333	
1-7/8-8 NS	Hand Tap	H6	6	201.90	201.90	201.90	199.36	194.30	183.76	1517335	1517336	1517337	
1-7/8-12 NS	Hand Tap	H6	6	201.62	186.11	170.60	152.02	146.85	146.85	1517339	1517340	1517341	
	Hand Tap	H8	6	236.01	211.35	189.09	174.70	146.85	146.85	1517343	1517344	1517345	
1-7/8-16 NS	Hand Tap	H5	6	225.35	194.01	183.10	150.85	146.85	146.85	1517347	1517348	1517349	
2"-4 1/2 NC	Hand Tap	H7	6	283.71	249.59	246.54	211.35	202.56	191.90	1517353	1517354	1517355	
2"-8 NS	Hand Tap	H6	6	218.02	218.02	218.02	211.35	202.56	191.90	1517357	1517358	1517359	
2"-12 NS	Hand Tap	H6	6	214.06	188.30	186.11	169.06	163.38	163.38	1517373	1517374	1517375	
	Hand Tap	H8	6	242.93	213.76	211.22	191.90	163.38	163.38	1517377	1517378	1517379	
2"-16 NS	Hand Tap	H5	6	214.06	188.30	186.11	169.06	163.38	163.38	1517381	1517382	1517383	
2"-20 NS	Hand Tap	H5	6	264.12	234.13	218.82	199.09	163.87	163.38	1517385	1517386	1517387	
2-1/8-8 NS	Hand Tap	H6	6	242.13	242.13	242.13	242.13	242.13	242.13	1517389	1517390	1517391	
2-1/8-12-NS	Hand Tap	H6	6	211.49	206.82	203.89	193.76	187.36	179.90	1517393	1517394	1517395	
2-1/8-16 NS	Hand Tap	H5	6	270.11	252.13	228.80	193.76	187.36	180.19	1517397	1517398	1517399	
2-1/4-4 1/2-NC	Hand Tap	H7	6	345.28	345.28	345.28	274.64	269.58	266.26	1517401	1517402	1517403	
2-1/4-8 NS	Hand Tap	H6	6	263.72	263.72	263.72	263.72	263.72	263.72	1517405	1517406	1517407	
2-1/4-12-NS	Hand Tap	H6	6	217.35	211.08	208.42	206.15	206.15	206.15	1517409	1517410	1517411	
2-1/4-16 NS	Hand Tap	H5	6	304.23	270.02	254.52	234.13	216.15	208.29	1517413	1517414	1517415	
2-3/8-8 NS	Hand Tap	H6	6	323.02	323.02	323.02	308.90	308.90	308.90	1517417	1517418	1517419	
2-3/8-12-NS	Hand Tap	H6	6	272.92	272.92	272.92	262.39	262.39	262.39	1517421	1517422	1517423	
2-3/8-16 NS	Hand Tap	H5	6	337.02	293.18	272.92	262.39	262.39	262.39	1517425	1517426	1517427	
2-1/2-4 NC	Hand Tap	H7	6	391.52	391.52	391.52	347.00	338.88	332.75	1517429	1517430	1517431	
2-1/2-8 NS	Hand Tap	H6	6	380.05	380.05	380.05	351.15	348.60	345.37	1517433	1517434	1517435	
2-1/2-12-NS	Hand Tap	H6	6	273.19	273.19	273.19	273.19	273.19	273.19	1517443	1517444	1517445	
2-1/2-16 NS	Hand Tap	H5	6	380.87	333.95	329.56	289.05	273.19	273.19	1517447	1517448	1517449	

- Prices shown for tools in table above are for Bright (uncoated / untreated) tools ONLY
- Additional Charge for Surface Treatments (Bronze Oxide, Steam Oxide & Nitride) . . . Use (List Price x 1.20) + 1 extra week for delivery
- Additional Charge for Coatings (TiN, TiCN, ZrN, and TiAlN) . . . Use (List Price x 1.35) + 1 extra week for delivery



For FlashTap information call:
800.639.1776

Semi-Special Threading Program

Metric

USD

SIZE	DESCRIPTION	O.D. TOL	# FLT	Class of Fit	1	2	3	6	12	24	TAPER EDP#	PLUG EDP#	BOTTOM EDP#	SHIPPING IN 24-48 HOURS (except where noted)	
M1.6x0.35	Hand Tap	D3	2	6H	20.12	18.56	17.02	15.47	13.98	13.98		1520010		72 hours	
	Spiral Point	D3	2	6H	24.88	22.97	21.06	19.14	17.51	17.51		1520008		72 hours	
M1.8x0.35	Hand Tap	D3	2	6H	18.87	17.43	15.98	14.52	13.17	13.17	1520021	1520022	1520023		
	Spiral Point	D3	2	6H	22.57	20.83	19.10	17.36	15.75	15.75		1520020			
M2x0.4	Hand Tap	D3	3	6H	17.99	16.60	17.99	13.84	12.62	12.62	1520033	1520034	1520035		
	Spiral Point	D3	2	6H	20.65	19.06	17.48	15.89	14.52	14.52		1520032			
M2.2x0.45	Hand Tap	D3	3	6H	15.53	14.60	13.13	11.95	10.86	10.86	1520045	1520046	1520047		
	Spiral Point	D3	2	6H	17.46	16.12	14.78	13.44	12.49	12.49		1520044			
M2.5x0.45	Hand Tap	D1	3	4H	47.25	23.09	14.92	12.49	10.59	9.63	1520051	1520052	1520053		
	Spiral Point	D1	2	4H	48.43	24.74	16.14	13.71	11.95	10.73		1520050			
M3x0.5	Hand Tap	D1	3	4H	45.08	21.76	12.49	10.59	8.82	8.01	1520063	1520064	1520065		
	Spiral Point	D1	2	4H	46.19	22.80	13.71	11.95	10.05	9.36		1520062			
	Spiral Point	D5	2		86.31	51.03	38.27	28.51	21.17	18.06		1521021			
	30° Spiral Flute	D3	2	6H	24.17	22.31	20.50	18.59	16.97	16.97		1520074	1520075		
	52° Spiral Flute	D3	2	6H	25.24	23.29	21.35	19.41	17.78	17.78		1520078	1520079		
	+ .076mm Spiral Point	D7	2		86.31	51.03	38.27	28.51	21.17	18.06		1520938			
M3.5x0.6	Hand Tap	D1	3	4H	43.74	20.35	12.49	10.59	9.23	8.55	1520084	1520085	1520086		
	Spiral Point	D1	2	4H	44.56	21.16	13.71	11.95	10.45	9.77		1520083			
	30° Spiral Flute	D4	2	6H	19.57	18.07	16.56	15.06	13.71	13.71		1520101	1520102		
	52° Spiral Flute	D4	2	6H	19.57	18.07	16.56	15.89	14.52	14.52		1520105	1520106		
	+ .127mm Hand	D11	3	Plating	19.77	18.25	16.73	15.20	13.84	13.84		1520111	1520112	1520113	
	+ .127mm Sp. Point	D11	2	Plating	21.35	19.70	18.07	16.42	15.06	15.06			1520110		
M4x0.7	Hand Tap	D2	4	4H	43.74	20.35	12.49	10.59	9.23	8.55	1520123	1520124	1520125		
	Spiral Point	D2	2	4H	44.56	21.16	13.71	11.95	10.45	9.77		1520122			
	+ .076mm Spiral Point	D7	2		74.91	53.33	50.89	30.81	17.51	14.92		1520923			
	30° Spiral Flute	D4	2	6H	19.58	18.07	16.56	15.06	13.71	13.71		1520140	1520141		
	52° Spiral Flute	D4	3	6H	20.65	19.06	17.48	15.89	14.52	14.52		1520144	1520145		
	+ .127mm Hand	D11	4	Plating	19.77	18.25	16.72	15.20	13.84	13.84		1520150	1520151	1520152	
+ .127mm Sp. Point	D11	2	Plating	21.35	19.71	18.07	16.42	15.06	15.06	1520149					
M4.5x0.75	Hand Tap	D2	4	4H	43.74	20.35	12.49	10.59	9.23	8.55	1520162	1520163	1520164		
	Spiral Point	D2	2	4H	44.56	21.16	13.71	11.95	10.45	9.77		1520161			
	52° Spiral Flute	D4	2	6H	20.65	19.06	17.48	15.89	14.52	14.52		1520183	1520184		
	+ .127mm Hand	D11	4	Plating	19.77	18.25	16.72	15.20	13.84	13.84		1520189	1520190	1520191	1 week
	+ .127mm Sp. Point	D11	2	Plating	21.35	19.71	18.07	16.42	15.06	15.06			1520188		
M5x0.8	Hand Tap	D2	4	4H	58.24	36.03	27.21	20.63	15.47	12.49	1520201	1520202	1520203		
	Spiral Point	D2	2	4H	45.87	30.70	25.49	21.58	16.42	13.44		1520200			
	+ .076mm Spiral Point	D7	2		78.85	53.48	49.63	30.03	16.93	14.47		1520924			
	+ .127mm Hand	D11	4	Plating	20.29	18.73	17.17	15.61	14.12	14.12		1520228	1520229	1520230	
	+ .127mm Sp. Point	D11	2	Plating	21.70	20.03	18.36	16.69	15.34	15.34			1520227		
M5x0.5	Hand Tap	D3	4	6H	77.50	52.39	35.97	18.86	15.06	12.90	1520909	1520910	1520911		
	Spiral Point	D3	2	6H	78.85	53.48	37.32	20.22	16.14	14.25		1520912			
M6x1.0	Hand Tap	D3	4	4H	45.83	22.21	12.90	10.59	9.10	8.29	1520240	1520241	1520242		
	Spiral Point	D3	2	4H	46.58	22.95	14.25	12.08	10.32	9.77		1520239			
	52° Spiral Flute	D5	3	6H	22.57	20.84	19.10	17.36	15.75	15.75		1520261	1520262		
	L.H. Hand Tap	D5	4	6H	10.78	9.95	9.12	8.29	7.74	7.74		1520253			
	+ .127mm Hand	D11	4	Plating	10.94	10.10	9.25	8.41	7.74	7.74		1520267	1520268	1520269	
	+ .127mm Sp. Point	D11	2	Plating	12.52	11.56	10.60	9.63	8.55	8.55			1520266		
M6x0.75	Hand Tap	D3	4	4H	45.83	22.21	12.90	10.59	9.10	8.29	1520279	1520280	1520281		
	Spiral Point	D3	2	4H	46.58	22.95	14.25	12.08	10.32	9.77		1520278			
M6x0.50	Hand Tap	D3	4	6H	85.37	65.35	51.87	37.05	20.63	16.69	1520975	1520976	1520977		

- Prices shown for tools in table above are for Bright (uncoated / untreated) tools ONLY
- Additional Charge for Surface Treatments (Bronze Oxide, Steam Oxide & Nitride) . . . Use (List Price x 1.20) + 1 extra week for delivery
- Additional Charge for Coatings (TiN, TiCN, ZrN, and TiAlN) . . . Use (List Price x 1.35) + 1 extra week for delivery

For FlashTap information call:
800.639.1776



Semi-Special Threading Program

Metric (con't)

USD

SIZE	DESCRIPTION	O.D. TOL	# FLT	Class of Fit	1	2	3	6	12	24	TAPER EDP#	PLUG EDP#	BOTTOM EDP#	SHIPPING IN 24-48 HOURS (except where noted)
M7x1.0	Hand Tap	D3	4	4H	46.27	22.58	13.98	11.27	10.45	9.90	1520284	1520285	1520286	
	Spiral Point	D3	2	4H	47.39	23.70	15.34	12.62	11.81	10.99		1520283		
	+ .127mm Hand	D11	4	Plating	13.58	12.54	11.49	9.51	9.51	9.51	1520308	1520309	1520310	
	+ .127mm Sp. Point	D11	2	Plating	15.36	14.18	13.00	10.59	10.59	10.59		1520307		
M8x1.25	Hand Tap	D3	4	4H	46.27	22.58	13.98	11.27	10.45	9.90	1520318	1520319	1520320	
	Spiral Point	D3	2	4H	47.39	23.70	15.34	12.62	11.81	10.99		1520317		
	52° Spiral Flute	D5	3	6H	21.17	21.17	21.17	19.28	19.28	19.28		1520337	1520338	
	+ .127mm Hand	D11	4	Plating	13.41	12.38	11.35	9.51	9.51	9.51	1520342	1520343	1520344	
+ .127mm Sp. Point	D11	2	Plating	14.28	13.18	12.09	10.18	10.18	10.18		1520341			
M8x1.0	Hand Tap	D3	4	4H	46.27	22.58	13.98	11.27	10.45	9.90	1520352	1520353	1520354	
	Spiral Point	D3	2	4H	47.39	23.70	15.34	12.62	11.81	10.99		1520351		
	Hand Tap	D5	4	6H	10.94	10.10	9.25	7.74	7.74	7.74	1520357	1520358	1520359	
	Spiral Point	D5	2	6H	12.52	11.56	10.60	8.55	8.55	8.55		1520356		
	52° Spiral Flute	D5	3	6H	44.19	40.79	37.39	30.92	30.92	30.92		1520371	1520372	
	+ .127mm Hand	D11	4	Plating	13.41	12.38	11.35	9.51	9.51	9.51	1520375	1520376	1520377	
+ .127mm Sp. Point	D11	2	Plating	15.36	14.18	13.00	10.73	10.73	10.73		1520374			
M8x0.75	Hand Tap	D5	4	6H	81.29	66.02	54.97	37.32	21.30	16.01	1520940	1520941	1520942	
M8x0.5	Hand Tap	D4	4	6H	81.29	57.00	54.97	37.32	21.30	16.01		1521024	1521025	
M10x1.5	Hand Tap	D3	4	4H	59.39	31.07	20.36	17.51	15.75	15.20	1520385	1520386	1520387	
	Spiral Point	D3	3	4H	60.95	32.64	21.58	18.86	17.11	16.29		1520384		
	52° Spiral Flute	D5	3	6H	44.19	40.79	37.39	33.85	30.92	30.92		1520404	1520405	
	L.H. Hand Tap	D6	4	6H	22.76	21.01	19.26	17.68	15.89	15.89	1520395	1520396	1520397	
	+ .127mm Hand	D11	4	Plating	22.06	20.37	18.67	15.47	15.47	15.47	1520409	1520410	1520411	
+ .127mm Sp. Point	D11	3	Plating	18.33	18.33	18.33	16.69	16.69	16.69		1520408			
M10x1.25	Hand Tap	D3	4	4H	59.39	30.99	20.36	17.51	15.75	15.20	1520419	1520420	1520421	
	Spiral Point	D3	3	4H	60.95	32.64	21.58	18.73	17.11	16.29		1520418		
	Hand Tap	D5	4	6H	20.48	18.90	17.33	15.22	14.49	14.25	1520424	1520425	1520426	
	Spiral Point	D5	3	6H	21.18	19.55	17.92	16.56	15.15	14.92		1520423		
	52° Spiral Flute	D5	3	6H	44.19	40.79	37.39	35.71	31.24	30.92		1520438	1520439	
	+ .127mm Hand	D11	4	Plating	22.06	20.37	18.67	16.39	15.69	15.47	1520442	1520443	1520444	
+ .127mm Sp. Point	D11	3	Plating	23.82	21.99	20.16	18.26	17.17	16.69		1520441			
M10x1.0	Hand Tap	D3	4	4H	19.94	18.41	16.87	14.09	13.85	13.84	1520447	1520448	1520449	
	Hand Tap	D5	4	6H	89.45	68.93	55.29	40.71	24.15	19.41	1520944	1520945	1520946	
	Spk. Plug Tap	D3	4		19.94	18.41	16.87	16.00	15.22	13.84		1520448	1520449	
	L.H. Hand Tap	D5	4	6H	89.45	68.93	55.29	40.71	24.15	19.41	1520948	1520949	1520950	
	Spiral Point	D5	3	6H	90.67	69.67	56.48	42.08	25.37	20.76		1520978		
M11x1.5	Hand Tap	D6	4	6H	59.39	31.07	21.58	18.73	17.36	16.42	1520452	1520453	1520454	
	Spiral Point	D6	3	6H	60.95	32.64	22.80	19.95	18.59	17.91		1520451		
M11x1.0	Hand Tap	D5	4	6H	92.84	72.64	60.81	41.54	25.24	19.81	1520984	1520985	1520986	
M12x1.75	Hand Tap	D3	4	4H	61.77	33.46	22.67	21.17	18.73	17.91	1520457	1520458	1520459	
	Spiral Point	D3	3	4H	63.27	35.02	24.57	22.39	19.81	19.14		1520456		
	52° Spiral Flute	D6	3	6H	53.29	49.19	45.09	40.39	38.26	37.26		1520476	1520477	
	L.H. Hand Tap	D6	4	6H	63.27	35.02	24.57	22.39	19.81	19.14		1520468		
	+ .127mm Hand	D11	4	Plating	28.29	26.28	24.26	22.24	19.38	18.46	1520481	1520482	1520483	
	+ .127mm Sp. Point	D11	3	Plating	30.40	28.23	26.06	23.89	20.95	19.95		1520480		
M12x1.50	Hand Tap	D6	4	6H	105.80	74.21	57.96	39.49	24.02	18.86	1520905	1520906	1520907	
	Spiral Point	D6	3	6H	97.18	69.22	62.71	43.57	27.29	21.04		1521027		
M12x1.25	Hand Tap	D3	4	4H	61.48	33.46	22.67	21.17	18.73	17.91	1520491	1520492	1520493	
	Spiral Point	D3	3	4H	63.27	35.02	24.57	22.39	19.81	19.14		1520490		
	Hand Tap	D5	4	6H	26.40	24.52	22.64	20.75	18.23	17.36	1520496	1520497	1520498	
	Spiral Point	D5	3	6H	30.08	26.28	24.26	22.24	19.38	18.46		1520495		
	52° Spiral Flute	D5	3	6H	57.39	53.29	49.19	45.09	39.12	37.26		1520510	1520511	
	+ .127mm Hand	D11	4	Plating	28.29	26.28	24.26	22.24	19.38	18.46	1520514	1520515	1520516	

- Prices shown for tools in table above are for Bright (uncoated / untreated) tools ONLY
- Additional Charge for Surface Treatments (Bronze Oxide, Steam Oxide & Nitride) . . . Use (List Price x 1.20) + 1 extra week for delivery
- Additional Charge for Coatings (TiN, TiCN, ZrN, and TiAlN) . . . Use (List Price x 1.35) + 1 extra week for delivery

Semi-Special Threading Program

Metric (con't)

\$USD

SIZE	DESCRIPTION	O.D. TOL	# FLT	Class of Fit	1	2	3	6	12	24	TAPER EDP#	PLUG EDP#	BOTTOM EDP#	SHIPPING IN 24-48 HOURS (except where noted)
M12x1.0	Hand Tap	D5	4	6H	105.80	74.21	60.81	41.54	25.24	19.81	1520889	1520890	1520891	
	Spiral Point	D5	3	6H	107.75	76.14	62.71	43.57	27.29	21.30		1520914		
M14x2.0	Hand Tap	D3	4	4H	64.21	38.01	29.96	26.60	25.24	25.24	1520524	1520525	1520526	
	Spiral Point	D3	3	4H	69.50	40.58	32.40	29.04	27.69	27.69		1520523		
M14x1.5	Hand Tap	D3	4	4H	64.21	38.01	29.96	26.60	25.24	25.24	1520539	1520540	1520541	
	Spiral Point	D3	3	4H	69.50	40.58	31.28	29.04	27.69	27.69		1520538		
	Hand Tap	D6	4	6H	32.81	30.29	27.76	26.50	26.00	25.24	1510544	1520546	1520547	
	Spiral Point	D6	3	6H	36.00	33.23	30.46	29.07	28.52	27.69		1520543		
M14x1.25	Spk. Plg. Hand	D4	4		32.81	30.29	27.76	26.50	26.00	25.24	1520555	1520556	1520557	
M14x1.0	Hand Tap	D5	4	6H	107.45	75.85	62.43	44.65	28.51	25.24	1520901	1520902	1520903	
M15x1.0	Hand Tap	D5	4	6H	103.29	81.59	68.82	51.87	35.17	31.35	1520988	1520989	1520990	
M16x2.0	Hand Tap	D4	4	4H	72.89	42.21	31.76	31.76	30.40	30.40	1520560	1520561	1520562	
	Spiral Point	D4	3	4H	75.46	44.93	40.91	39.35	34.79	32.98		1520559		
	L.H. Hand	D7	4	6H	46.93	43.32	36.28	34.63	31.87	30.95		1020571		
	+ .127mm Hand + .127mm Sp. Point	D11 D11	4 3	Plating Plating	46.93 43.60	43.32 38.01	36.28 35.70	34.63 34.73	31.87 33.23	30.95 32.98	1520575	1520576	1520577	
M16x1.5	Hand Tap	D3	4	4H	72.89	42.21	31.76	31.76	30.40	30.40	1520580	1520581	1520582	
	Spiral Point	D3	3	4H	75.46	44.93	40.91	39.35	34.79	32.98		1520579		
	Hand Tap	D6	4	6H	40.11	33.40	30.40	29.28	28.19	27.52	1520585	1520586	1520587	
	Spiral Point L.H. Hand	D6 D6	3 4	6H 6H	42.18 36.10	40.86 36.10	37.18 32.98	35.99 32.98	35.80 30.95	34.79 30.95		1520584 1520591		
M18x2.5	Hand Tap	D4	4	4H	76.00	47.46	42.55	38.44	35.97	35.97	1520595	1520596	1520597	
	Hand Tap	D7	4	6H	42.18	40.86	37.18	35.99	35.80	34.79	1520600	1520601	1520602	
	L.H. Hand	D7	4	6H	42.18	40.86	37.18	35.99	35.80	34.79	1520605	1520606	1520607	
M18x1.5	Hand Tap	D3	4	4H	76.00	47.46	42.55	38.44	35.80	34.79	1520610	1520611	1520612	
	Spk. Plg. Hand	D4	4		42.18	40.86	37.18	35.99	35.80	34.79	1520615	1520616	1520617	
	Hand Tap	D6	4	6H	42.18	40.86	37.18	35.99	35.80	34.79	1520620	1520621	1520622	
	L.H. Hand	D6	4	6H	49.33	45.47	37.18	35.99	35.80	34.79		1520626	1520627	
M18x1.0	Hand Tap	D5	4	6H	124.05	88.36	68.28	52.66	38.14	37.05	1520893	1520894	1520895	
M20x2.5	Hand Tap	D4	4	4H	87.41	56.60	47.46	44.93	43.86	43.07	1520630	1520631	1520632	
	L.H. Hand Tap	D7	4	6H	69.38	62.29	59.53	56.62	51.03	48.69		1520641		
	+ .127mm Hand	D11	4	Plating	60.50	54.46	52.53	49.55	48.45	48.45	1520645	1520646	1520647	
M20x1.5	Hand Tap	D3	4	4H	87.41	56.60	47.46	41.80	41.80	41.80	1520650	1520651	1520652	
	Hand Tap	D6	4	6H	47.46	46.02	41.88	41.80	41.80	41.80	1520655	1520656	1520657	
	+ .127mm Hand	D11	4	Plating	60.50	54.46	52.53	49.55	48.45	46.77	1520665	1520666	1520667	
M22x2.5	Hand Tap	D4	4	4H	98.95	65.83	58.05	54.17	51.87	48.58	1520670	1520671	1520672	
	Hand Tap	D7	4	6H	66.10	59.53	56.94	54.17	51.87	48.58	1520675	1520676	1520677	
M22x1.5	Hand Tap	D3	4	4H	98.95	65.83	58.05	54.17	51.87	48.58	1520685	1520686	1520687	
	Hand Tap	D6	4	6H	66.10	59.53	56.94	54.17	51.87	48.58	1520690	1520691	1520692	
	+ .127mm Hand	D11	4		67.73	60.95	58.34	55.44	54.16	54.16	1520700	1520701	1520702	
M24x3.0	Hand Tap	D4	4	4H	101.25	79.36	76.08	72.21	56.94	53.05	1520705	1520706	1520707	
	L.H. Hand	D8	4	6H	96.20	81.81	78.16	74.43	70.98	70.98	1520715	1520716	1520717	
	+ .127mm Hand	D11	4	Plating	63.78	59.44	54.42	54.42	54.42	54.42	1520720	1520721	1520722	
M24x2.0	Hand Tap	D4	4	4H	101.25	79.36	76.08	72.21	56.94	53.58	1520725	1520726	1520727	
	Hand Tap	D7	4	6H	94.64	79.36	76.08	72.21	58.77	58.77	1520730	1520731	1520732	
	L.H. Hand	D7	4	6H	96.20	81.81	78.16	74.43	70.98	70.98	1520735	1520736	1520737	
M24x1.5	Hand Tap	D6	4	6H	94.64	79.36	76.08	72.21	58.77	58.77	1520916	1520917	1520918	
M26x1.5	Hand Tap	D6	6	6H	141.02	116.61	111.85	91.89	70.58	65.01	1520980	1520981	1520982	
M27x3.0	Hand Tap	D5	4	4H	124.43	116.77	115.57	98.80	78.99	78.99	1520740	1520741	1520742	
	Hand Tap	D8	4	6H	124.43	116.77	115.57	98.80	78.99	78.99	1520745	1520746	1520747	
	L.H. Hand	D8	4	6H	124.43	116.77	115.57	98.80	78.99	78.99	1520750	1520751	1520752	
M27x2.0	Hand Tap	D5	4	4H	124.43	116.77	115.57	98.80	78.99	78.99	1520755	1520756	1520757	
	Hand Tap	D7	4	6H	124.43	116.77	115.57	98.80	78.99	78.99	1520760	1520761	1520762	

- Prices shown for tools in table above are for Bright (uncoated / untreated) tools ONLY
- Additional Charge for Surface Treatments (Bronze Oxide, Steam Oxide & Nitride) . . . Use (List Price x 1.20) + 1 extra week for delivery
- Additional Charge for Coatings (TiN, TiCN, ZrN, and TiAlN) . . . Use (List Price x 1.35) + 1 extra week for delivery

For FlashTap information call:
800.639.1776



Semi-Special Threading Program

Metric (con't)

\$USD

SIZE	DESCRIPTION	O.D. TOL	# FLT	Class of Fit	1	2	3	6	12	24	TAPER EDP#	PLUG EDP#	BOTTOM EDP#	SHIPPING IN 24-48 HOURS (except where noted)
M30x3.5	Hand Tap	D5	4	4H	166.83	153.50	135.62	—	—	—	1520770	1520771	1520772	
	Hand Tap	D9	4	6H	166.83	153.50	135.62	—	—	—	1520775	1520776	1520777	
	L.H. Hand	D9	4	6H	166.83	153.50	135.62	—	—	—	1520780	1520781	1520782	
M30x2.0	Hand Tap	D5	4	4H	166.83	153.50	135.62	—	—	—	1520785	1520786	1520787	
	Hand Tap	D7	4	6H	166.83	153.50	135.62	—	—	—	1520790	1520791	1520792	
M30x1.5	Hand Tap	D6	6	6H	157.31	152.70	130.03	—	—	—	1520897	1520898	1520899	
M33x3.5	Hand Tap	D5	4	4H	169.80	165.19	146.05	—	—	—	1520800	1520801	1520802	
	Hand Tap	D9	4	6H	169.80	165.19	146.05	—	—	—	1520805	1520806	1520807	
M33x2.0	Hand Tap	D5	4	4H	169.80	165.19	146.05	—	—	—	1520815	1520816	1520817	
	Hand Tap	D7	4	6H	169.80	165.19	146.05	—	—	—	1520820	1520821	1520822	
M35x1.5	Hand Tap	D6	6	6H	169.80	165.19	146.05	—	—	—	1520956	1520957	1520958	
M36x4.0	Hand Tap	D5	4	4H	211.47	193.15	189.27	—	—	—	1520830	1520831	1520832	
	Hand Tap	D9	4	6H	211.47	193.15	189.27	—	—	—	1520835	1520836	1520837	
M36x3.0	Hand Tap	D5	4	4H	211.47	193.15	189.27	—	—	—	1520845	1520846	1520847	
	Hand Tap	D8	4	6H	211.47	193.15	189.27	—	—	—	1520850	1520851	1520852	
M36x2.0	Hand Tap	D7	6	6H	211.47	193.15	189.27	—	—	—	1520920	1520921	1520922	
M36x1.5	Hand Tap	D6	6	6H	183.50	179.30	158.25	—	—	—		1520961	1520962	
	Hand Tap	D9	6	6H	183.50	179.30	158.25	—	—	—		1520961	1520962	
M39x4.0	Hand Tap	D6	6	4H	243.63	222.57	217.65	—	—	—	1520860	1520861	1520862	
	Hand Tap	D9	6	6H	243.63	222.57	217.65	—	—	—	1520865	1520866	1520867	
M39x3.0	Hand Tap	D6	6	4H	297.08	222.57	217.65	—	—	—	1520875	1520876	1520877	
	Hand Tap	D8	6	6H	297.08	222.57	217.65	—	—	—	1520880	1520881	1520882	
M40x1.5	Hand Tap	D6	6	6H	254.46	223.47	189.27	—	—	—	1520971	1520972	1520973	
M42x4.5	Hand Tap	D10	6	6H	300.51	277.29	248.65	—	—	—	1520964	1520965	1520966	

- Prices shown for tools in table above are for Bright (uncoated / untreated) tools ONLY
- Additional Charge for Surface Treatments (Bronze Oxide, Steam Oxide & Nitride) . . . Use (List Price x 1.20) + 1 extra week for delivery
- Additional Charge for Coatings (TiN, TiCN, ZrN, and TiAlN) . . . Use (List Price x 1.35) + 1 extra week for delivery

MADE TO ORDER - Hand Taps & Spiral Point Taps

RIGHT AND LEFT HAND

USD

Machine Screw/Fractional			Metric									Additional Cost for Spiral Point	SHIPPING IN 48-72 HOURS (except where noted)
MAX SIZE	SIZE	MAX TPI	SIZE MM	MIN PITCH	1	2	3-5	6-11	12-23	24-47	48-71		
.065	0	100	M1.5,M1.6	0.3	130.33	96.22	68.09	47.18	29.31	23.85	21.72	2.00	1 week for Spiral Point
.078	1	100	M1.8		129.94	95.81	67.70	46.78	28.78	23.45	21.06	1.88	1 week for Spiral Point
.091	2	100	M2,M2.2	0.3	128.20	94.35	66.10	45.30	27.32	21.85	19.86	1.73	1 week for Spiral Point
.104	3	100	M2.3,M2.5	0.3	122.60	88.62	61.97	40.77	23.58	19.46	17.18	1.33	1 week for Spiral Point
.117	4	100	--	--	117.80	85.02	57.83	36.77	20.65	17.32	15.06	1.33	1 week for Spiral Point
.130	5	100	M3	0.3	117.80	85.02	57.83	36.77	20.65	17.32	15.06	1.33	1 week for Spiral Point
.145	6	100	M3.5	0.3	128.34	82.22	55.44	33.84	18.52	15.58	13.19	1.06	1 week for Spiral Point
.171	8	100	M4	0.3	115.01	82.22	55.44	33.84	18.52	15.58	13.19	1.06	1 week for Spiral Point
.197	10	100	M4.5,M5	0.3	115.01	82.22	55.44	33.84	18.52	15.58	13.19	1.06	1 week for Spiral Point
.223	12	100	M5.5	0.3	118.47	85.02	58.37	36.92	20.12	16.52	13.73	1.06	1 week for Spiral Point
.260	14	80	M6	0.3	119.26	86.35	59.17	38.37	21.46	17.59	15.19	1.20	1 week for Spiral Point
.260	1/4	80	--	--	119.26	86.35	59.17	38.37	21.46	17.59	15.19	1.20	1 week for Spiral Point
.323	5/16	80	M7,M8	0.3	120.59	87.55	60.10	39.57	22.39	17.72	15.58	1.33	1 week for Spiral Point
.385	3/8	80	M9,M10	0.3	124.73	90.62	64.10	42.78	24.52	19.86	17.06	1.33	1 week for Spiral Point
.448	7/16	80	M11	0.3	127.80	94.35	67.70	44.77	27.86	22.12	19.86	1.47	1 week for Spiral Point
.510	1/2	80	M12	0.3	132.33	97.95	69.97	48.63	30.25	25.45	22.00	2.00	1 week for Spiral Point
.573	9/16	64	M14	0.4	134.19	99.94	71.96	51.84	33.18	27.98	23.85	2.53	1 week for Spiral Point
.635	5/8	64	M16	0.4	138.85	105.41	77.55	58.50	39.72	34.11	31.19	2.67	1 week for Spiral Point
.709	11/16	64	M18	0.4	145.26	111.27	83.03	64.10	43.44	38.37	34.78		Spiral point is a Special Only
.760	3/4	64	--	--	150.19	117.00	88.62	69.82	48.24	42.78	39.05	4.30	1 week for Spiral Point
.823	13/16	64	M20	0.4	159.91	122.60	96.22	77.29	52.50	48.24	44.64		Spiral point is a Special Only
.885	7/8	64	M22	0.4	166.98	123.00	103.95	85.02	60.37	55.97	52.10		
.948	15/16	64	M24	0.4	169.51	134.19	107.54	88.62	64.90	59.31	54.51		
1.010	1"	64	M25	0.4	184.96	147.92	120.87	102.08	76.09	69.57	63.84		

- Prices shown for tools in table above are for Bright (uncoated / untreated) tools ONLY
- Additional Charge for Surface Treatments (Bronze Oxide, Steam Oxide & Nitride) . . . Use (List Price x 1.20) + 1 extra week for delivery
- Additional Charge for Coatings (TiN, TiCN, ZrN, and TiAlN) . . . Use (List Price x 1.35) + 1 extra week for delivery

MADE TO ORDER - Hand Taps (Large Sizes)

Shipping in 48-72 hours

RIGHT AND LEFT HAND

\$USD

FRACTIONAL		METRIC		QUANTITY/LIST PRICE							
SIZE	MAX TPI	SIZE MM	MIN PITCH	TABLE	# OF FLUTES	1	2	3-5	6-11	12-23	24-47
1-1/16	13	M27	2	302	4	203.09	164.57	136.73	117.00	87.29	81.16
	55	M27	0.5	303	6	184.70	144.86	118.20	97.29	72.36	66.64
1-1/8	13			302	4	206.82	168.43	140.59	120.87	91.02	85.15
	55			303	6	186.03	146.06	119.26	98.49	73.69	67.97
1-3/16	13	M30	2	302	4,6	226.95	187.77	160.57	140.86	109.00	101.14
1-1/4	55	M30	0.5	303	6	203.22	163.38	136.32	115.81	86.62	81.68
	13			302	4,6	230.67	191.50	164.44	144.58	113.01	104.88
1-5/16	55			303	6	205.89	165.92	138.46	117.41	89.42	83.95
	13	M33	2	302	4,6	253.46	214.81	186.17	148.32	126.47	111.14
1-3/8	55	M33	0.5	303	6	218.68	175.64	148.32	128.59	103.02	94.48
	13			302	4,6	256.66	217.88	188.83	155.52	128.06	112.87
1-7/16	55			303	6	220.68	178.17	150.59	130.46	104.61	95.68
	13	M36	2	302	4	288.77	263.46	226.29	196.95	149.92	129.94
1-1/2	55	M36	0.5	303	6	235.86	189.62	163.24	143.25	117.80	109.14
	13	M38	2	302	4,6	291.58	267.32	227.88	205.49	151.12	131.39
1-5/8	55	M38	0.5	303	6	239.60	193.36	165.11	144.86	119.26	110.48
	9	M39	3	302	6	318.77	292.51	254.52	226.95	192.96	168.71
1-3/4	55	M39	0.5	303	6	283.04	253.19	214.95	188.83	157.78	136.32
	9	M42	3	302	6	356.60	310.10	272.25	243.33	214.15	192.96
1-7/8	55	M42	0.5	303	6	298.10	268.91	230.41	203.09	172.71	154.18
	9	M45	3	302	6	384.86	362.33	312.10	285.97	255.20	230.28
2"	55	M45	0.5	303	6	311.30	283.84	247.20	218.68	188.04	167.37
	9	M48	3	302	6	403.64	379.39	328.88	303.16	272.25	247.47
2-1/8	47	M48	0.5	303	6	326.35	299.16	260.79	234.27	206.69	182.83
	9			302	6	441.50	414.58	364.07	335.29	306.24	281.44
2-1/4	47			303	6	392.45	366.07	315.30	289.05	256.26	233.60
	9	M56	3	302	6	545.16	517.59	455.88	410.18	373.40	348.20
2-3/8	47	M56	0.5	303	6	418.71	399.39	354.75	323.96	293.44	268.91
	9			302	6	571.56	546.51	482.94	438.70	396.32	369.39
2-1/2	47			303	6	441.50	422.58	375.00	348.20	320.50	290.37
	9			302	6	607.27	583.01	516.39	471.62	435.10	410.05
	47			303	6	530.11	494.39	434.83	388.59	348.20	323.02

- Prices shown for tools in table above are for Bright (uncoated / untreated) tools ONLY
- Additional Charge for Surface Treatments (Bronze Oxide, Steam Oxide & Nitride) . . . Use (List Price x 1.20) + 1 extra week for delivery
- Additional Charge for Coatings (TiN, TiCN, ZrN, and TiAlN) . . . Use (List Price x 1.35) + 1 extra week for delivery

MADE TO ORDER - HSS Spiral Flute (Right Hand Only)

Shipping in 1 Week

Fractional, Metric

\$USD

	SIZE	MAX TPI	SIZE MM	MIN PITCH	1	2	3-5	6-11	12-23	24-47	48-71
²⁾	3	100	M2.3,M2.5,M2.6	0.3	130.33	96.22	67.97	45.30	28.38	24.52	22.25
²⁾	4	100	--	--	124.60	90.62	62.36	41.45	25.05	20.79	18.92
²⁾	5	100	M3	0.3	124.60	90.62	62.36	41.45	25.05	20.79	18.92
¹⁾ ²⁾	6	100	M3.5	0.3	122.60	88.62	60.37	38.37	23.05	18.92	16.27
¹⁾ ²⁾	8	100	M4	0.3	122.60	88.62	60.37	38.37	23.05	18.92	16.27
¹⁾ ²⁾	10	100	M4.5,M5	0.3	122.60	88.62	60.37	38.37	23.05	18.92	16.27
¹⁾ ²⁾	12	100	M5.5	0.3	126.20	92.08	63.56	41.17	24.26	20.52	17.86
¹⁾ ²⁾	14	80	M6	0.3	126.47	92.36	64.10	41.45	24.52	20.52	18.12
¹⁾ ²⁾	1/4	80	--	--	126.47	92.36	64.10	41.45	24.52	20.52	18.12
¹⁾ ²⁾	5/16	80	M7,M8	0.3	127.53	94.08	64.90	43.44	25.99	21.19	18.92
¹⁾ ²⁾	3/8	80	M9,M10	0.3	132.20	97.95	69.82	47.18	28.38	24.52	20.79
¹⁾ ²⁾	7/16	80	M11	0.3	135.79	103.02	73.69	50.90	32.11	28.38	24.52
¹⁾ ²⁾	1/2	80	M12	0.3	139.52	106.87	77.29	56.78	36.77	31.99	28.38
¹⁾ ²⁾	5/8	64	M16	0.4	154.72	119.54	90.62	67.97	47.18	41.45	38.24
²⁾	11/16	64	M18	0.4	162.18	125.93	95.81	75.29	52.91	47.18	43.44
¹⁾ ²⁾	3/4	64	--	0.4	167.91	133.93	111.27	83.03	58.50	54.36	51.04
²⁾	7/8	64	M22	0.4	188.70	150.85	122.60	102.08	75.43	69.82	65.96
²⁾	1"	64	--	--	211.35	172.05	143.38	128.20	95.54	90.22	86.75

¹⁾ SLOW SPIRAL - 30° HELIX R.H. • 30° SPIRAL PLUG OR BOTTOMING

²⁾ HIGH SPIRAL - 52° HELIX • 52° SPIRAL PLUG OR BOTTOMING

- Prices shown for tools in table above are for Bright (uncoated / untreated) tools ONLY
- Additional Charge for Surface Treatments (Bronze Oxide, Steam Oxide & Nitride) . . . Use (List Price x 1.20) + 1 extra week for delivery
- Additional Charge for Coatings (TiN, TiCN, ZrN, and TiAlN) . . . Use (List Price x 1.35) + 1 extra week for delivery

MADE TO ORDER - HSS Projection Pipe Taps (Right Hand Only)

Shipping in 48 Hours

Fractional Table 311

\$USD

SIZE	1	2	3-5	6-11	12-23	24-47	48-71
1/16-27	127.13	93.96	65.83	43.85	25.84	21.46	26.47
1/8-27	130.46	97.29	69.29	47.18	29.18	25.05	31.31
1/4-18	137.92	104.61	77.03	55.70	36.92	32.39	42.30
3/8-18	146.85	112.61	85.02	65.70	45.30	40.51	54.20
1/2-14	167.77	132.33	106.74	86.35	68.49	57.57	79.43
3/4-14	182.70	145.92	119.40	100.48	75.43	70.36	97.97
1"-11 1/2	220.02	178.17	152.04	132.59	108.88	100.61	129.02
1 1/4-11 1/2	283.18	257.99	221.34	195.09	165.64	144.98	201.11
1 1/2-11 1/2	329.28	307.84	270.79	244.93	215.88	195.35	271.09
2"-11 1/2	421.10	393.92	349.14	314.36	283.45	259.06	359.30

- Note: All MADE TO ORDER Pipe Taps are Straight Flute ONLY. Limited range on Short Projections
- Prices shown for tools in table above are for Bright (uncoated / untreated) tools ONLY
- Additional Charge for Surface Treatments (Bronze Oxide, Steam Oxide & Nitride) . . . Use (List Price x 1.20) + 1 extra week for delivery
- Additional Charge for Coatings (TiN, TiCN, ZrN, and TiAlN) . . . Use (List Price x 1.35) + 1 extra week for delivery

MADE TO ORDER - HSS Thread Forming Taps (Right Hand Only)

Shipping in 48-72 Hours

Table 302

\$USD

Machine Screw, Fractional Size	Metric Size	1	2	3-5	6-11	12-23	24-47	48-71
#0	M1.5,M1.6	152.58	113.80	81.43	56.63	35.19	30.12	26.12
#1	M1.8	151.52	126.07	80.49	56.63	33.84	28.65	24.65
#2	M2,M2.2	150.59	111.68	79.29	53.97	32.91	27.86	23.85
#3	M2.3,M2.5,M2.6	143.25	105.55	72.36	47.84	28.52	23.58	20.65
#4	--	138.06	99.68	68.09	43.19	25.45	20.52	15.99
#5	M3	138.06	99.68	68.09	43.19	25.45	20.52	15.99
#6	M3.5	134.72	96.48	65.16	41.17	23.33	18.39	14.00
#8	M4	134.72	96.48	65.16	41.17	23.33	18.39	14.00
#10	M4.5,M5	134.72	96.48	65.16	41.17	23.33	18.39	14.00
#12	M5.5	139.26	101.28	68.77	44.38	24.52	20.52	15.99
1/4	M6	140.20	102.08	69.57	45.30	25.84	20.79	15.99
5/16	M7,M8	140.99	102.87	70.89	46.51	26.52	21.59	18.80
3/8	M9,M10	146.18	107.67	75.29	50.23	28.92	24.12	20.12
7/16	M11	150.85	111.94	79.56	54.24	33.05	27.98	22.66
1/2	M12	155.12	115.67	83.16	58.64	36.92	30.65	26.52
9/16	M14	158.05	118.74	86.21	62.51	39.97	33.84	29.98
5/8	M16	164.44	124.60	93.02	69.03	46.51	40.25	36.77
11/16	M18	170.05	130.19	97.29	75.95	51.17	45.18	40.77
3/4	--	176.18	137.00	105.41	83.03	56.90	50.64	46.78

- Prices shown for tools in table above are for Bright (uncoated / untreated) tools ONLY
- Additional Charge for TiN Coating. . . Use (List Price x 1.35) + 1 extra week for delivery

Table 302 – Hand Taps

GENERAL DIMENSIONS

Unless otherwise specified.

Special taps over 1.010" to 1.510" diameter inclusive, having 14 or more threads per inch or 1.75 millimeter pitch and finer, and sizes over 1.510" diameter with 10 or more threads per inch or 2.5 millimeter pitch and finer, will be made to general dimensions shown in Table 303. Special ground thread taps for Unified and American National form threads will be made to limits shown in Metal Cutting Tool Institute

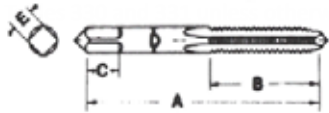

STYLE 1

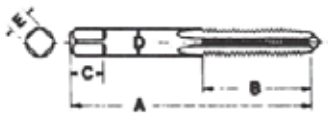

STYLE 2

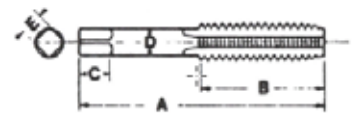

STYLE 3

Nominal Diameter Range - Inches		Machine Screw Size No.	Nominal Fractional Diameter Inches	Nominal Metric Diameter Millimeters	Tap Dimensions - Inches					
Over	To (Incl.)				Style	Overall Length A	Thread Length B	Square Length C	Shank Diameter D	Size of Square E
.052	.065	0	1/16	M1.6	1	1.5/8	5/16	3/16	.141	.110
.065	.078	1		M1.8	1	1.11/16	3/8	3/16	.141	.110
.078	.091	2		M2, M2.2	1	1.3/4	7/16	3/16	.141	.110
.091	.104	3	3/32	M2.5	1	1.13/16	1/2	3/16	.141	.110
.104	.117	4			1	1.7/8	9/16	3/16	.141	.110
.117	.130	5	1/8	M3, M3.15	1	1.15/16	5/8	3/16	.141	.110
.130	.145	6		M3.5	1	2"	11/16	3/16	.141	.110
.145	.171	8	5/32	M4	1	2.1/8	3/4	1/4	.168	.131
.171	.197	10	3/16	M4.5, M5	1	2.3/8	7/8	1/4	.194	.152
.197	.223	12	7/32		1	2.3/8	15/16	9/32	.220	.165
.223	.260	14	1/4	M6, M6.3	2	2.1/2	1"	5/16	.255	.191
.260	.323		5/16	M7, M8	2	2.23/32	1.1/8	3/8	.318	.238
.323	.395		3/8	M10	2	2.15/16	1.1/4	7/16	.381	.286
.395	.448		7/16		3	3.5/32	1.7/16	13/32	.323	.242
.448	.510		1/2	M12, M12.5	3	3.3/8	1.21/32	7/16	.367	.275
.510	.573		9/16	M14	3	3.19/32	1.21/32	1/2	.429	.322
.573	.635		5/8	M16	3	3.13/16	1.13/16	9/16	.480	.360
.635	.709		11/16	M18	3	4.1/32	1.13/16	5/8	.542	.406
.709	.760		3/4		3	4.1/4	2"	11/16	.590	.442
.760	.823		13/16	M20	3	4.15/32	2"	11/16	.652	.489
.823	.885		7/8	M22	3	4.11/16	2.7/32	3/4	.697	.523
.885	.948		15/16	M24	3	4.29/32	2.7/32	3/4	.760	.570
.948	1.010		1"	M25	3	5.1/8	2.1/2	13/16	.800	.600
1.010	1.073		1.1/16	M27	3	5.1/8	2.1/2	7/8	.896	.672
1.073	1.135		1.1/8		3	5.7/16	2.9/16	7/8	.896	.672
1.135	1.198		1.3/16	M30	3	5.7/16	2.9/16	1"	1.021	.766
1.198	1.260		1.1/4		3	5.3/4	2.9/16	1"	1.021	.766
1.260	1.323		1.5/16	M33	3	5.3/4	2.9/16	1.1/16	1.108	.831
1.323	1.385		1.3/8		3	6.1/16	3"	1.1/16	1.108	.831
1.385	1.448		1.7/16	M36	3	6.1/16	3"	1.1/8	1.233	.925

Continued on next page

NOTES

Ground thread taps, sizes .385" and smaller, have external center on thread end (may be removed on bottoming taps). Sizes .233" and smaller, have external center on shank end; sizes .224" thru .385" have internal center in thread and shank ends.

For standard thread limits and tolerances for Unified and American national form threads see United States Cutting Tool Institute Tables 325 and 327.

For eccentricity tolerances of tap elements see United States Cutting Tool Institute Table 317.

All special hand taps 1/4" diameter and over, with a nominal diameter more than .010" over the diameter of any size listed in this table, will be furnished with the length, shank and square dimensions of the next larger size tap.

For FlashTap information call:
800.639.1776



USCTI Tables

Table 302 – Hand Taps

Continued from page 22

Nominal Diameter Range - Inches		Machine Screw Size No.	Nominal Fractional Diameter Inches	Nominal Metric Diameter Millimeters	Tap Dimensions - Inches					
Over	To (Incl.)				Style	Overall Length A	Thread Length B	Square Length C	Shank Diameter D	Size of Square E
1.448	1.510		1.1/2		3	6.3/8	3"	1.1/8	1.233	.925
1.510	1.635		1.5/8	M39	3	6.11/16	3.3/16	1.1/8	1.305	.979
1.635	1.760		1.3/4	M42	3	7"	3.3/16	1.1/4	1.430	1.072
1.760	1.885		1.7/8		3	7.5/16	3.9/16	1.1/4	1.519	1.139
1.885	2.010		2"	M48	3	7.5/8	3.9/16	1.3/8	1.644	1.233
2.010	2.135		2.1/8		3	8"	3.9/16	1.3/8	1.769	1.327
2.135	2.260		2.1/4	M56	3	8.1/4	3.9/16	1.7/16	1.894	1.420
2.260	2.385		2.3/8		3	8.1/2	4"	1.7/16	2.019	1.514
2.385	2.510		2.1/2		3	8.3/4	4"	1.1/2	2.100	1.575
2.510	2.635		2.5/8	M64	3	8.3/4	4"	1.1/2	2.225	1.669
2.635	2.760		2.3/4		3	9.1/4	4"	1.9/16	2.350	1.762
2.760	2.885		2.7/8	M72	3	9.1/4	4"	1.9/16	2.475	1.856
2.885	3.010		3"		3	9.3/4	4.9/16	1.5/8	2.543	1.907
3.010	3.135		3.1/8		3	9.3/4	4.9/16	1.5/8	2.668	2.001
3.135	3.260		3.1/4	M80	3	10"	4.9/16	1.3/4	2.793	2.095
3.260	3.385		3.3/8		3	10"	4.9/16	1.3/4	2.883	2.162
3.385	3.510		3.1/2		3	10.1/4	4.15/16	2"	3.008	2.256
3.510	3.635		3.5/8	M90	3	10.1/4	4.15/16	2"	3.133	2.350
3.635	3.760		3.3/4		3	10.1/2	5.5/16	2.1/8	3.217	2.413
3.760	3.885		3.7/8		3	10.1/2	5.5/16	2.1/8	3.342	2.506
3.885	4.010		4"	M100	3	10.3/4	5.5/16	2.1/4	3.467	2.600

Tolerances

Element	Nominal Diameter Range - Inches		Direction	Tolerances - Inches
	Over	To (Incl.)		Ground Thread
Length Overall - A	.052	1.010	Plus or Minus	1/32
	1.010	4.010	Plus or Minus	1/16
Length of Thread - B	.052	.223	Plus or Minus	3/64
	.223	.510	Plus or Minus	1/16
	.510	1.510	Plus or Minus	3/32
Length of Square - C	1.510	4.010	Plus or Minus	1/8
	.052	1.010	Plus or Minus	1/32
	1.010	4.010	Plus or Minus	1/16
Diameter of Shank - D	.052	.223	Minus	.0015
	.223	.635	Minus	.0015
	.635	1.010	Minus	.002
	1.010	1.510	Minus	.002
	1.510	2.010	Minus	.003
	2.010	4.010	Minus	.003
Size of Square - E	.052	.510	Minus	.004
	.510	1.010	Minus	.006
	1.010	2.010	Minus	.008
	2.010	4.010	Minus	.010

Table 303 – Fine Pitch Taps

Short Series

Unless otherwise specified, special taps 1.010" to 1.510" diameter inclusive have 14 or more threads per inch or 1.75 millimeter pitch and finer, and sizes over 1.510" diameter with 10 or more threads per inch, or 2.5 millimeter pitch and finer, will be made to the general dimensions shown below.

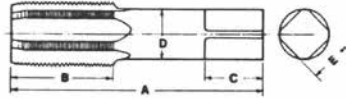

Nominal Diameter Range - Inches		Nominal Fractional Diameter Inches	Nominal Metric Diameter Millimeters	Tap Dimensions - Inches				
Over	To (Incl.)			Overall Length A	Thread Length B	Square Length C	Shank Diameter D	Size of Square E
1.010	1.073	1.1/16	M37	4"	1.1/2	7/8	.896	.672
1.073	1.135	1.1/8		4"	1.1/2	7/8	.896	.672
1.135	1.198	1.3/16	M30	4"	1.1/2	1"	1.021	.766
1.198	1.260	1.1/4		4"	1.1/2	1"	1.021	.766
1.260	1.323	1.5/16	M33	4"	1.1/2	1"	1.108	.831
1.323	1.385	1.3/8		4"	1.1/2	1"	1.108	.861
1.385	1.448	1.7/16	M36	4"	1.1/2	1"	1.233	.925
1.448	1.510	1.1/2		4"	1.1/2	1"	1.233	.925
1.510	1.635	1.5/8	M39	5"	2"	1.1/8	1.305	.979
1.635	1.760	1.3/4	M42	5"	2"	1.1/4	1.430	1.072
1.760	1.885	1.7/8		5"	2"	1.1/4	1.519	1.139
1.885	2.010	2"	M48	5"	2"	1.3/8	1.644	1.233
2.010	2.135	2.1/8		5.1/4	2"	1.3/8	1.769	1.327
2.135	2.260	2.1/4	M56	5.1/4	2"	1.7/16	1.894	1.420
2.260	2.385	2.3/8		5.1/4	2"	1.7/16	2.019	1.514
2.385	2.510	2.1/2		5.1/4	2"	1.1/2	2.100	1.575
2.510	2.635	2.5/8	M64	5.1/2	2"	1.1/2	2.100	1.575
2.635	2.760	2.3/4		5.1/2	2"	1.1/2	2.100	1.575
2.760	2.885	2.7/8	M72	5.1/2	2"	1.1/2	2.100	1.575
2.885	3.010	3"		5.1/2	2"	1.1/2	2.100	1.575
3.010	3.135	3.1/8		5.3/4	2"	1.1/2	2.100	1.575
3.135	3.260	3.1/4	M80	5.3/4	2"	1.1/2	2.100	1.575
3.260	3.385	3.3/8		5.3/4	2"	1.1/2	2.100	1.575
3.385	3.510	3.1/2		5.3/4	2"	1.1/2	2.100	1.575
3.510	3.635	3.5/8	M90	6"	2"	1.3/4	2.100	1.575
3.635	3.760	3.3/4		6"	2"	1.3/4	2.100	1.575
3.760	3.885	3.7/8		6"	2"	1.3/4	2.100	1.575
3.885	4.010	4"	M100	6"	2"	1.3/4	2.100	1.575

NOTE

For tolerances see table 302.

For standard thread limits and tolerances see United States Cutting Tool Institute Tables 327A and 321.

For eccentricity tolerances of tap elements see United States Cutting Too Institute Table 317.

All special taps 1.1/16" diameter and over, with a nominal diameter more than .010" over the diameter of any size listed in this table, will be furnished with the length, shank and square dimensions of the next larger size tap.

USCTI Tables

Table 311 – Pipe Taps - Straight & Taper

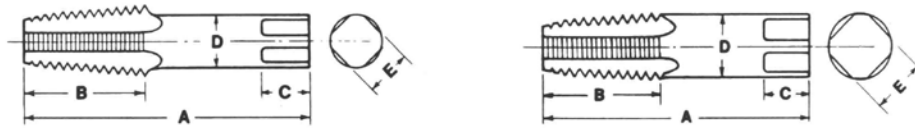

Tolerances

Dimensions - Inches					
Nominal Size Inches	Overall Length A	Thread Length B	Length of Square C	Shank Diameter D	Size of Square E
1/16	2.1/8	11/16	3/8	.3125	.234
1/8*	2.1/8	3/4	3/8	.3125	.234
1/8	2.1/8	3/4	3/8	.4375	.328
1/4	2.7/16	1.1/16	7/16	.5625	.421
3/8	2.9/16	1.1/16	1/2	.7000	.531
1/2	3.1/8	1.3/8	5/8	.6875	.515
3/4	3.1/4	1.3/8	11/16	.9063	.679
1"	3.3/4	1.3/4	13/16	1.1250	.843
1.1/4	4"	1.3/4	15/16	1.3125	.984
1.1/2	4.1/4	1.3/4	1"	1.5000	1.125
2"	4.1/2	1.3/4	1.1/8	1.8750	1.406
2.1/2	5.1/2	2.9/16	1.1/4	2.2500	1.687
3"	6"	2.5/8	1.3/8	2.6250	1.968
3.1/2	6.1/2	2.11/16	1.1/2	2.8125	2.108
4"	6.3/4	2.3/4	1.5/8	3.0000	2.250

Element	Range	Direction	Tolerance Ground Thread
Overall Length - A	1/16" to 3/4" incl.	Plus or Minus	1/32
	1" to 4" incl.	Plus or Minus	1/16
Thread Length - B	1/16" to 3/4" incl.	Plus or Minus	1/16
	1" to 1.1/4" incl.	Plus or Minus	3/32
	1.1/2" to 4" incl.	Plus or Minus	1/8
Length of Square - C	1/16" to 3/4" incl.	Plus or Minus	1/32
	1" to 4" incl.	Plus or Minus	1/16
Shank Diameter - D	1/16" to 1/8" incl.	Minus	.0015
	1/4" to 1/2" incl.	Minus	.0020
	3/4" to 1" incl.	Minus	.0020
	1.1/4" to 4" incl.	Minus	.0030
Size of Square - E	1/16" to 1/8" incl.	Minus	.0040
	1/4" to 3/4" incl.	Minus	.0060
	1" to 4" incl.	Minus	.0080

* Smaller shanks

NOTE

For standard thread limits and tolerances see United States Cutting Tool Institute Tables 335, 335A and 338.

For eccentricity tolerances of tap elements see United States Cutting Tool Institute Table 317.

DIMENSIONS FOR COMBINED TAPER PIPE TAPS AND DRILLS

Size	Threads per Inch	Overall Length	Thread Length	Drill Length	Drill		Square Length	Shank Diameter	Size of Square
					Size	Decimal			
1/16	27	2.1/2	11/16	1/2	1/4	.2500	3/8	.312	.234
1/8	27	2.13/16	3/4	3/4	R	.3390	3/8	.437	.328
1/4	18	3.5/16	1.1/16	7/8	7/16	.4375	7/16	.562	.421
3/8	18	3.1/2	1.1/16	15/16	1/2	.5781	1/2	.700	.531
1/2	14	4.1/8	1.6/8	1"	5/8	.7031	5/8	.687	.515
3/4	14	4.3/8	1.3/8	1.1/8	11/16	.9219	11/16	.906	.679
1"	11.1/2	5"	1.3/4	1.1/4	13/16	1.1563	13/16	.1.125	.843

COMBINED TAP AND DRILL APPLICATION

Where practical, performing two operations with a single tool in a single work station will usually reduce the manufacturing cost of a part. These combined drills and taps are designed for this purpose.

The drill section produces a hole correctly sized for approximately 75% thread. Helical flutes provide the correct tool geometry to cut most low tensile strength material. We recommend use only in through holes no deeper than twice the tap diameter.

Statement of Policy

The Company warrants to original equipment manufacturers, distributors and industrial and commercial users of its products that each new product manufactured by the Company shall be free from material defects and workmanship for one year after delivery by the Company. The Company's exclusive obligation under this warranty is limited to furnishing a replacement for, or at its option, repairing or issuing credit for, any product which is, within one year from the date of delivery by the Company, returned freight prepaid to the plant designated by a representative of the Company and which upon inspection is determined by the Company to be materially defective in material or workmanship.

Complete information as to operating conditions, machine setup and application of cutting fluid should accompany any product returned for inspection. All defective products returned to the Company under this warranty shall be the Company's property. The provisions of this warranty shall not apply to any product of the Company which has been subjected to misuse, improper operating conditions, machine setup, application of cutting fluid, or which has been repaired or altered without authorization from the Company.

THIS WARRANTY IS IN LIEU OF ALL OTHER WARRANTIES, EXPRESSED OR IMPLIED, EXCEPT AS EXPRESSLY SET FORTH HEREIN, THE COMPANY MAKES NO WARRANTY, EXPRESSED OR IMPLIED, AS TO ANY MATTER WHATSOEVER INCLUDING ANY IMPLIED WARRANTY OF MERCHANTABILITY OR FITNESS FOR A PARTICULAR PURPOSE.

The Company's sole liability of any claim of any kind, whether in contract, tort, or otherwise, for any loss or damage arising out of, connected with, or resulting from the manufacture, sale, delivery or use of the products sold hereunder shall in no case exceed the amount actually paid to the Company for the applicable products, IN NO EVENT SHALL THE COMPANY BE LIABLE TO ANY ENTITY OR PERSON FOR ANY SPECIAL, INCIDENTAL, INDIRECT OR CONSEQUENTIAL DAMAGES HOWEVER CAUSED, ON ANY THEORY OF LIABILITY, AND WHETHER OR NOT THE COMPANY HAS BEEN ADVISED OF THE POSSIBILITY OF SUCH DAMAGES.

The Company neither assumes nor authorizes any other person or firm to assume for it any other obligation or liability in connection with its products. The purchaser acknowledges that there are no warranties implied by custom or usage in the trades of the purchaser of the Company, and that it is customary in the trades of purchaser and the Company that there are to be no warranties, and that any prior dealing between the purchaser and the Company or its authorized distributor does not imply any warranty from the Company. The limitations set forth in this section shall apply notwithstanding any failure of essential purpose of any limited remedy.

SIMPLY RELIABLE

As a professional you can judge the quality of work by just looking at the chip. Our chip is a clean and uncomplicated shape that in itself tells a story. It is a clear and consistent signal and that's why we use it as a symbol for being **Simply Reliable**.



Phone: 1-800-639-1776
Fax: 1-800-639-1876
cs@dormerpramet.com