



ALUMINIUM WINDOW & DOOR INSTALLATION GUIDES

Some of the contents of the manual refer to the
"An Industry Guide to the Correct Installation of Windows and Doors"
of the Australian Glass & Window Association.



instockwindows.com.au

Pre-installation care of windows

Windows should be stored in a clean, dry area away from cement, lime, paint, acid etc. and must be protected from building materials and loose debris such as wet plaster, mortar, paint and welding splatter.

- Store in a dry location, under cover where possible, to protect against damage
- Carry windows in the verticle position with sashes locked
- Do not rack frames out of square
- Prevent exposure to moisture particularly pooling and ponding
- Do not remove bands from double hung windows until after installation
- Do not remove corner braces until after installation.

Factors that contribute to installation problems

Installation problems such as incorrect fitting or the omission of flashings, smothered or missing weep holes, or the loss of continuity in the water barrier are the prime cause of leaks in window assemblies.

- Severity of exposure to wind is the most important factor in the specification and installation of windows and doors in openings. Components and installation practices acceptable in sheltered situations may quickly fail when exposed to the full force of the wind and rain.
- Follow the window manufacturer's installation specification for the appropriate Terrain Category and height of building; many manufacturers' brochures provide information for sheltered buildings no more than one storey high.

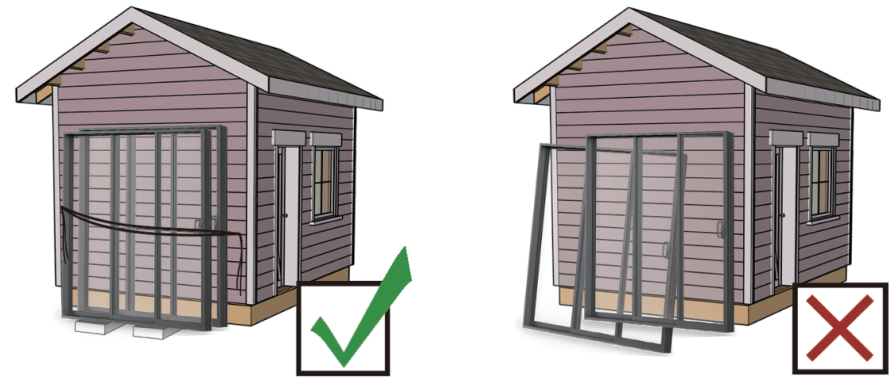

Handle and stack frames carefully on site. Stand them upright on their sills (bottom of the window as installed), raised off the ground on pieces of timber or bricks. Stand them against a flat, vertical surface such as a shed and tie firmly in position.

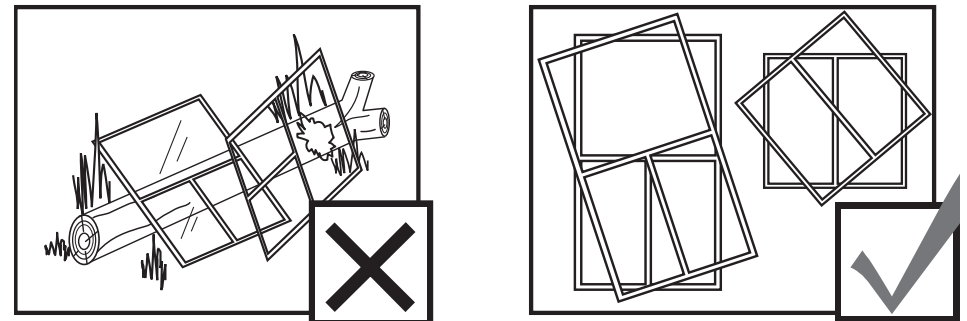

Do not lean windows against a tree or post as they are subject to permanent damage until installed into the building envelope. If the site is bare, lay frames flat on top of each other with weight evenly distributed to avoid buckling and distortion.

1. Fit flashing to window surround as required.
2. Measure the frame opening to ensure that there is sufficient room for the product and additional packing.

Stud Opening:

Height= O/A reveal size + adequate clearance

Width= O/A reveal size + adequate clearance

Clearance dimensions vary between manufacturer's products. For adequate clearance refer to window manufacturer's instruction

3. Frame must be packed plumb, square and not twisted between the openings. Ensure the sill is fully supported; failure to do so may result in sill roll on sliding windows. Sills on all windows and doors must be straight and level and should be packed and secured.
4. Secure aluminum windows by nailing through reveal in brick veneer applications. Timber windows should be secured by back nailing through stud, not face of frame stud. Alternatively, on cavity brick construction use galvanized building lugs located at 450mm maximum centres.
5. If it is not possible to back nail, wedges should be installed between the window and the building frame to prevent opening of the frame joints when nailing is carried out.
6. Keep sashes closed whilst installing frames.
7. Sill bricks should be at least 10 mm clear of window frame to allow settlement in brick veneer construction.
8. Do not stand on the windows or doors, or use them as a support for scaffolding, or slide material through the frame. It is important to prevent any damage to windows and doors during construction.
9. Do not permit weight of eaves or arch bars to bear on any window or door frame. **(Windows and doors are not load bearing)**
10. Remove cement mortar and plaster droppings from windows immediately, taking care to avoid scratching glass and, or frames, as permanent damage can result. Immediate attention must be given by washing off with water before material sets.

11. To ensure the satisfactory long term performance of sliding doors, the sill should be fully supported. Where the sill projects during construction the sill should be fully supported with temporary supports until sill bricks or tiles are installed.

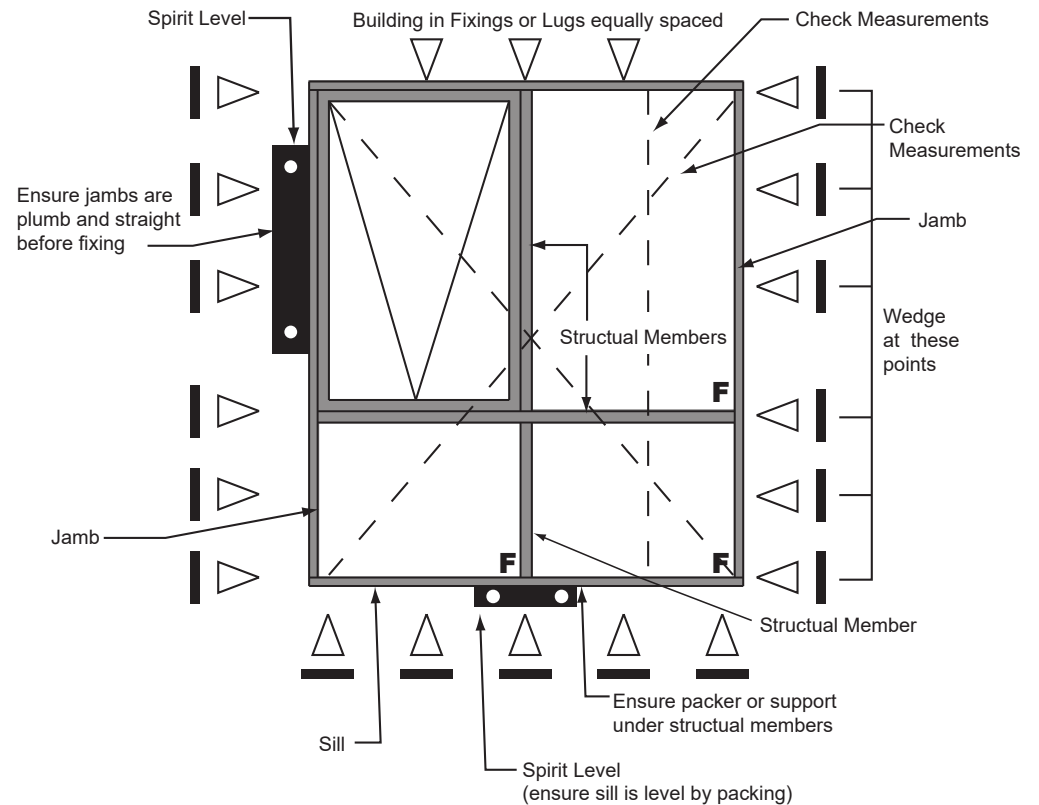

* Fix via building lugs, nails or shim at equally spaced arrow points.

General

It is the builder's responsibility to ensure that windows and doors are installed in such a way that water does not penetrate from the outer skin to the inner skin of the building envelope. The extent of the flashing required will depend on local weather conditions. In some instances only sill flashings may be required. In others jamb and head flashing may be required. For further information please refer to the relevant sections of the B.C.A.

Jamb Flashing

- Required in high wind locations to ensure that water which enters between the window jamb and the outer skin is drained to the sill flashing.
- Where jamb flashing overlaps sill flashing, the overlap should extend the full depth of the sill flashing.

Head Flashing

- Provided to stop water wetting the inner skin by bridging across the window or door head.
- Provided above any wall penetrations not specifically designed to stop water reaching the inner skin, ie; exhaust fans and ventilation ducts.
- Must project horizontally a minimum of 150mm both sides past the opening.
- Must be of approved materials to AS2904 and bonded at laps.
- Must be provided with weep holes to let the water out.

Sill Flashing

- Provided to stop water entering across underside of the window and wetting the inner skin.
- The window generates run off in down pours and sill flashing stops this water being blown across the cavity under the window.
- Some windows have drain holes which also direct water downwards into the cavity. The sill flashing also collects water which runs down the jamb flashing.
- Must project a minimum of 150mm both sides past the opening.
- Must be of approved materials to AS2904 and bonded at laps.
- The brickwork must be provided with weep holes to let the water out.

Special Care

- Special care is required on windows with undersill drainage used in a non cavity situation such as single skin block work.
- Where a subsill is used stop ends must be fitted and sealed.

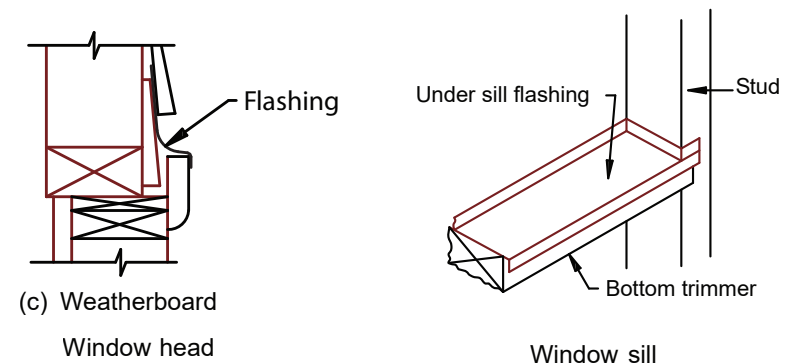
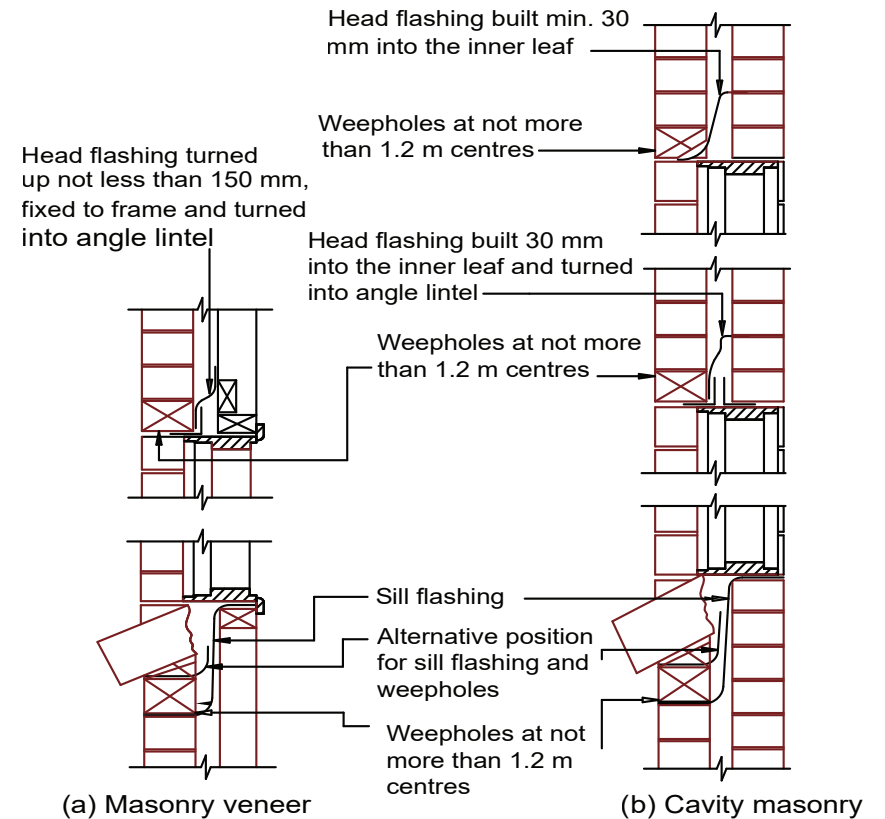

bi- fold door

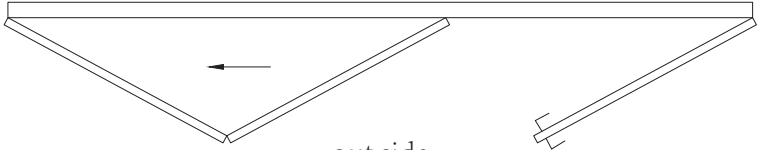
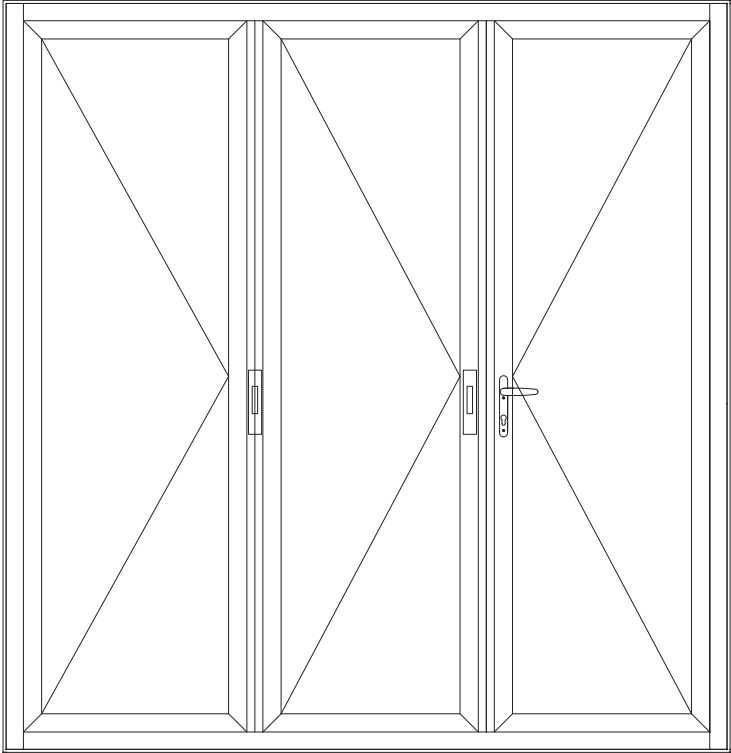

out side

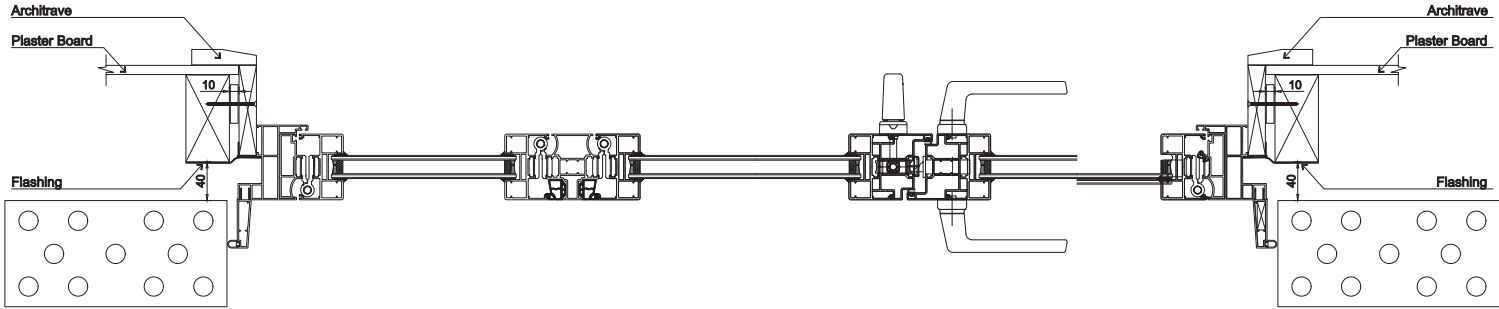
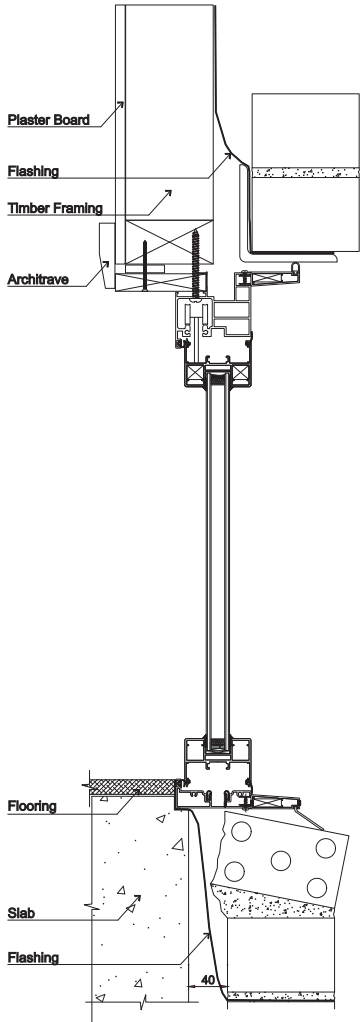

Sliding door - stacker

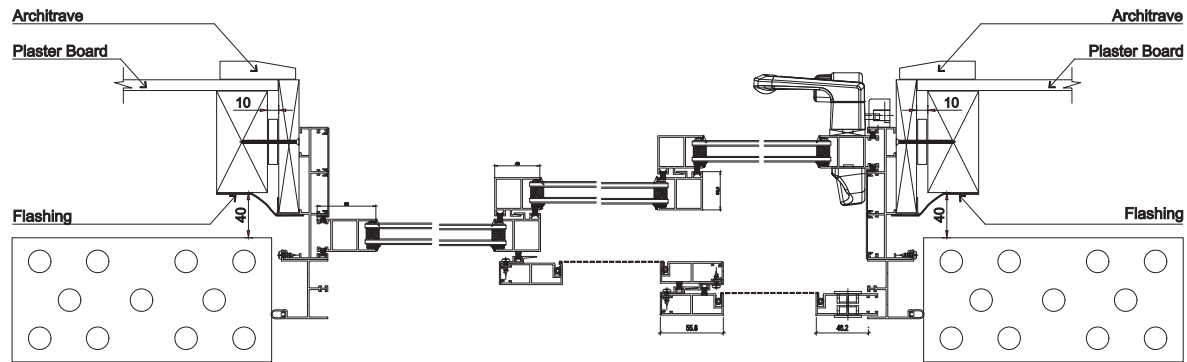
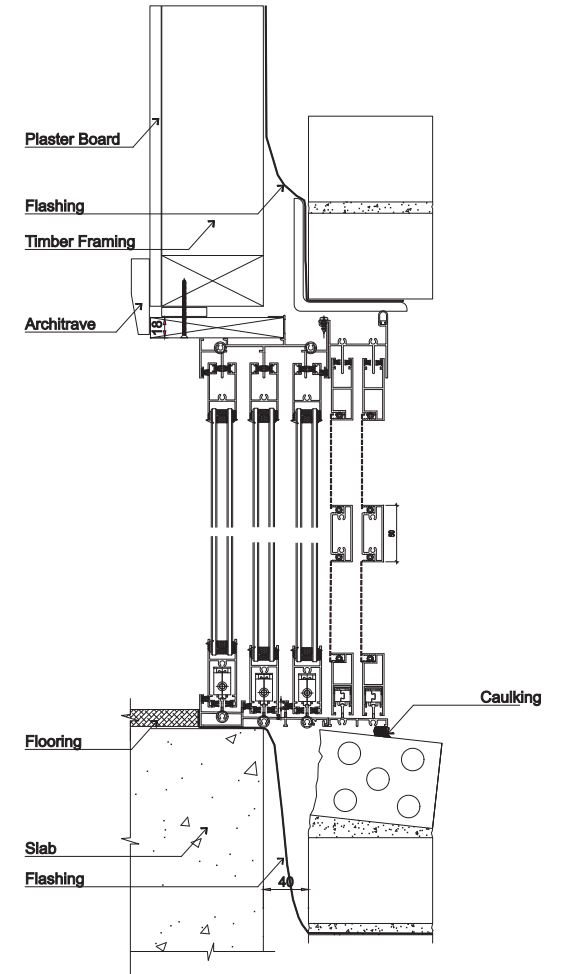
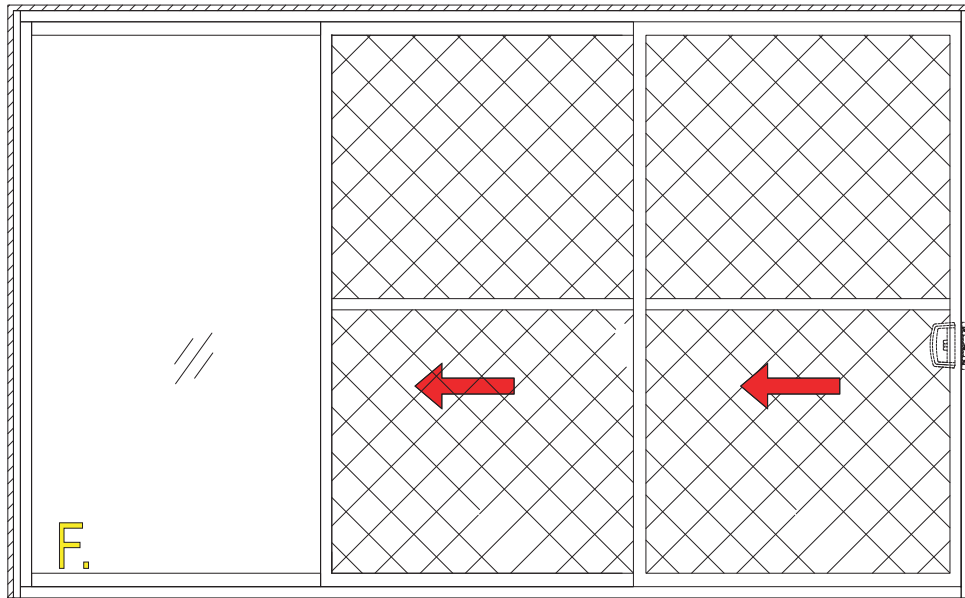

Awning window

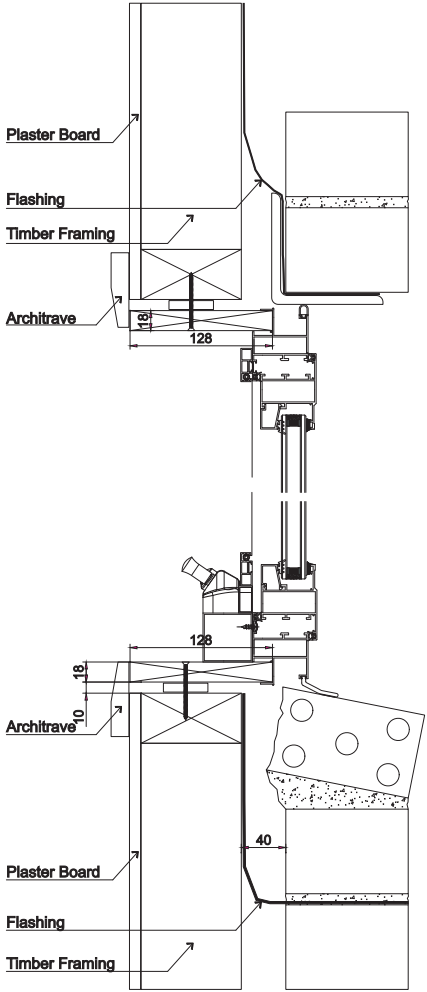
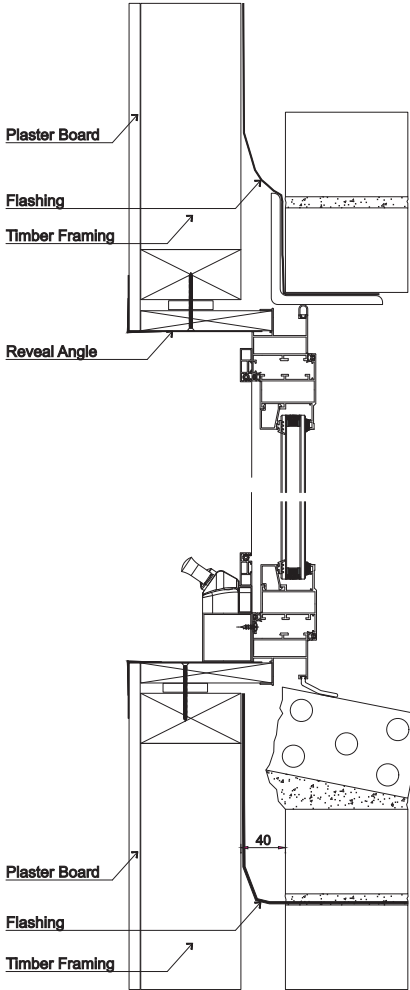
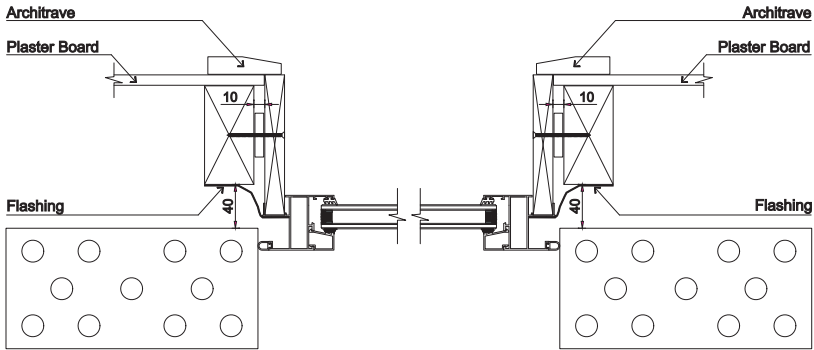
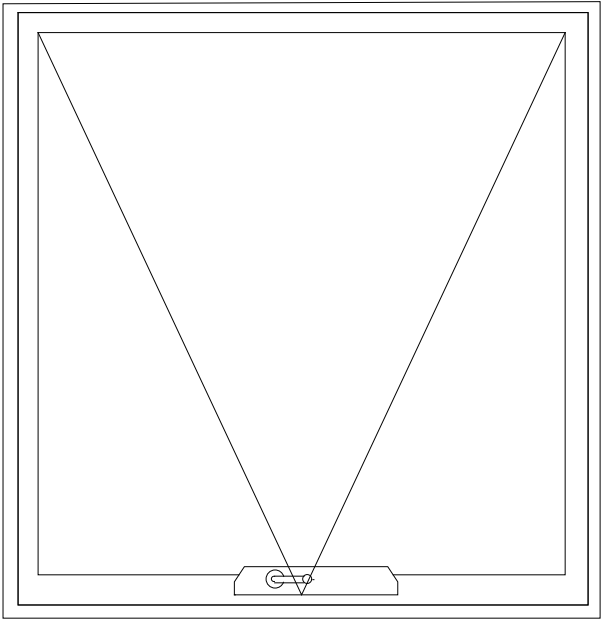

french door open inward & open outward

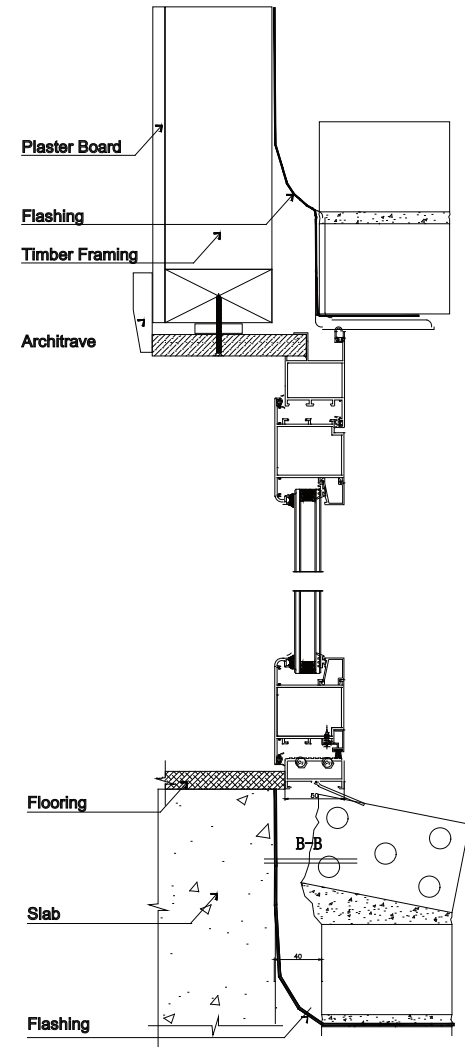
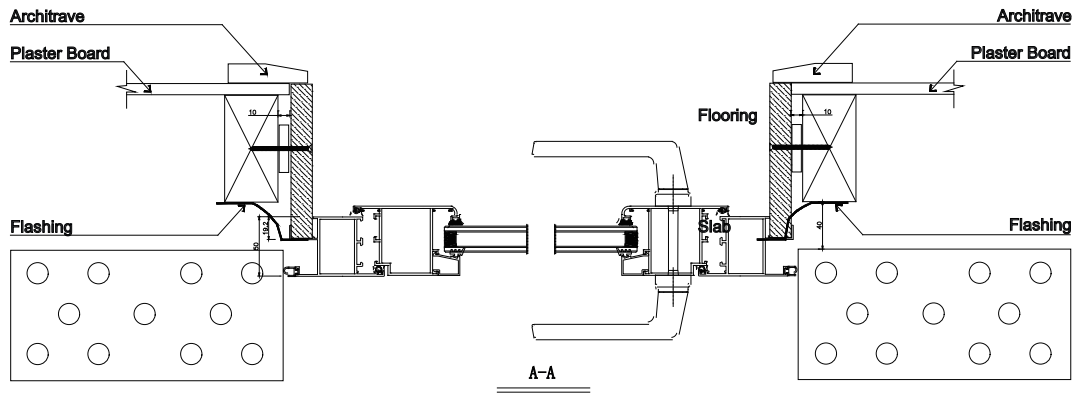
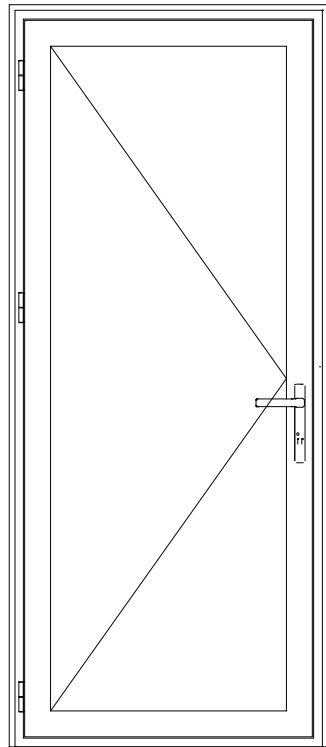

french door open inward & open outward

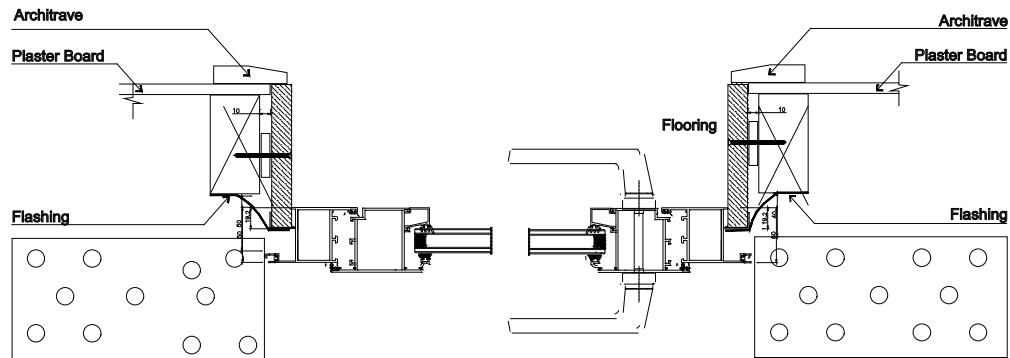
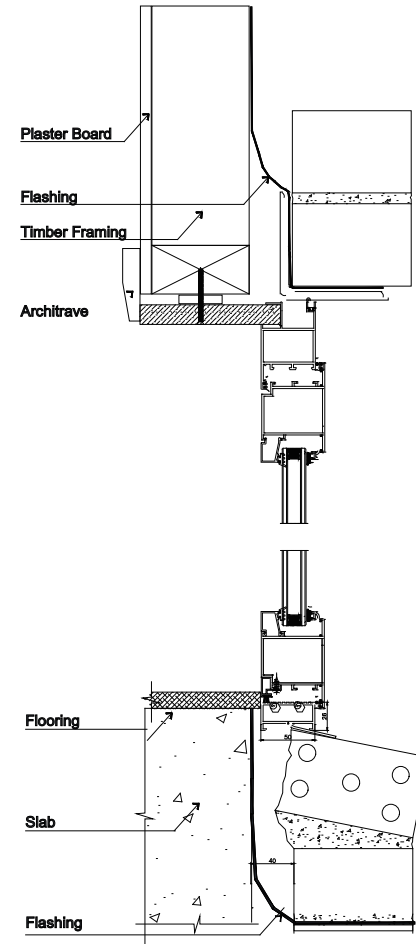
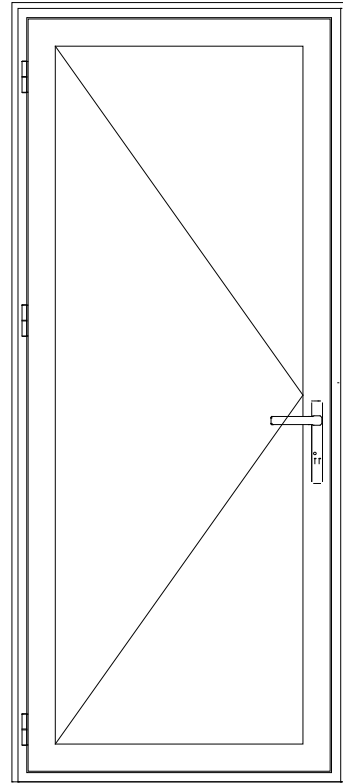

sliding door

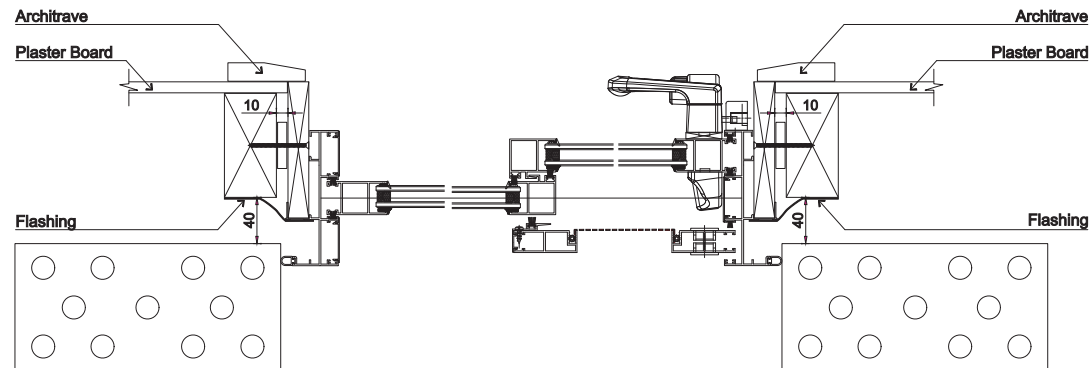
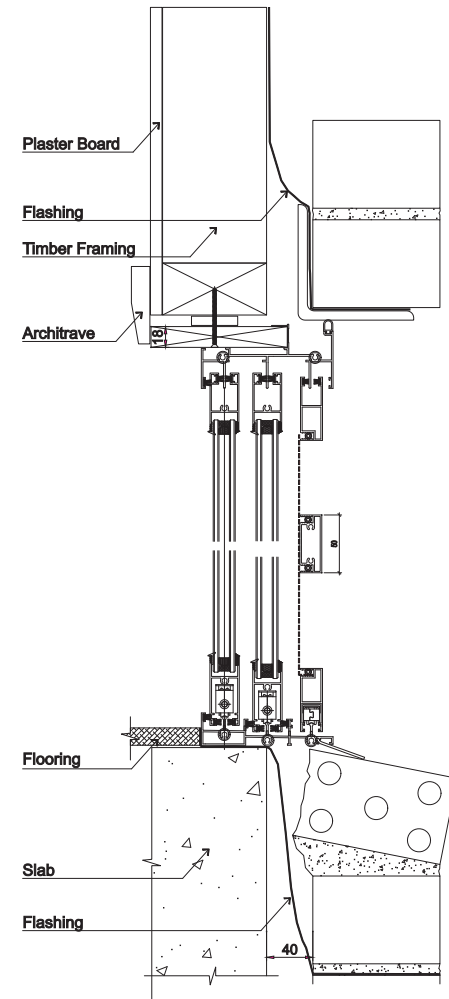
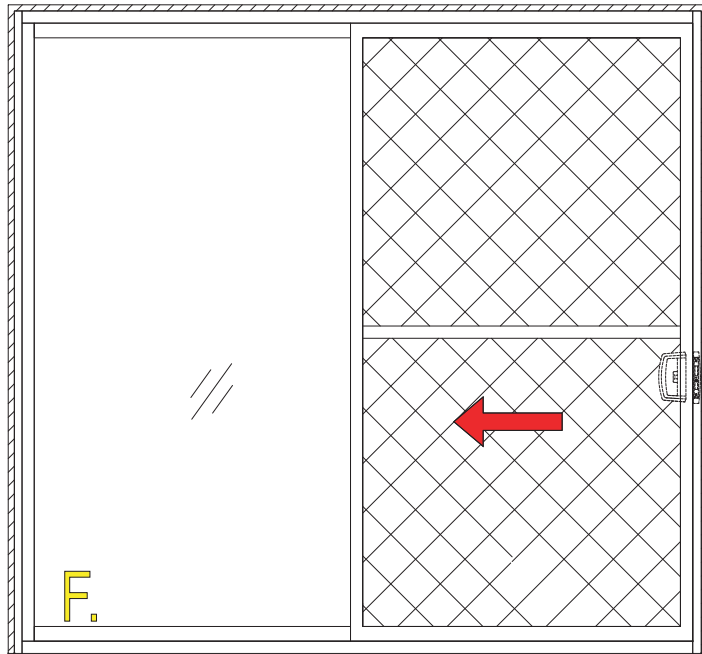

Soiling:

If removal of debris is delayed and scraping becomes necessary the finish may be damaged. Remove cement, mortar and other droppings immediately, using ample clean water and a sponge or rag to avoid permanent staining of finished surfaces.

Door Tracks and Sills:

Door tracks and window sills should be protected from planks, scaffolding and barrows.

Acid Spills:

Acid used for cleaning brickwork MUST be prevented from making contact with powdercoated or anodised aluminium windows and door surfaces. If any acid or similar corrosive material does come into contact with window or door surfaces those areas must be washed IMMEDIATELY with large quantities of clean water.

Use of Hose

If using a hose or similar apparatus to clean windows and/or doors ensure the hose nozzle/jet fitting is set to a fine spray as shown in the diagram. At NO time should a window or door be hit with a full force of a hose, nozzle/jet setting.

Glass Care

- To clean, simply wipe over the surface with a few drops of methylated spirits on a damp cloth, then polish the surface dry with a lint free cloth.
- Ensure that all cleaning cloths are free from any abrasive surfaces.
- Never remove abrasive materials such as mortar from the glass with a scraper. (To clean, flood with water and dab with a sponge. Dont scub with sponge or scratching will occur.)

Soiling

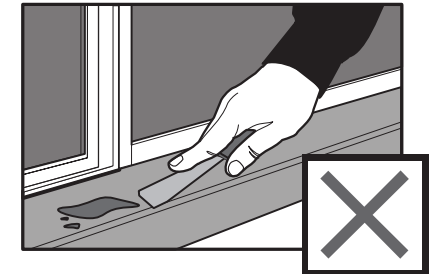
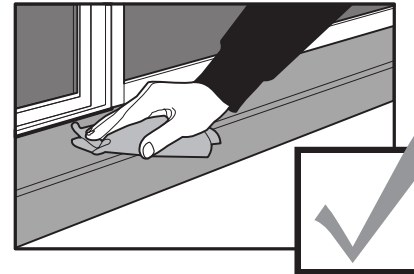

Door tracks & sills

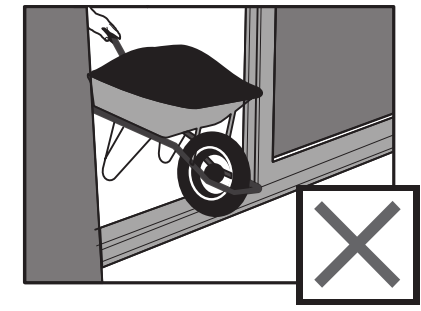
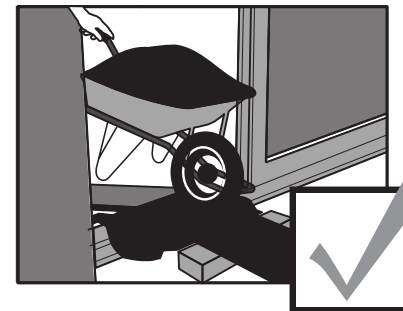

Cleaning

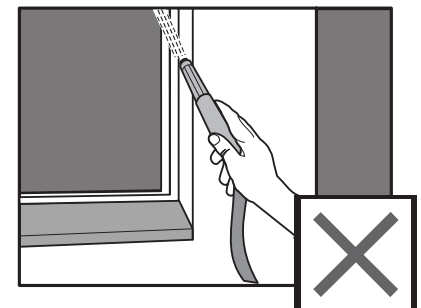
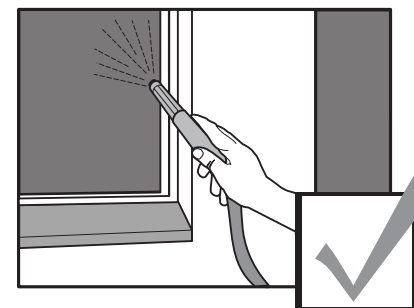

Further Information

Australian Aluminium Council

www.aluminium.org.au

Australian Building Codes Board

www.abcb.gov.au

Australian Vinyl Council

www.vinyl.org.au

Australian Window Association

www.awa.org.au

BUILdata - Building Products Information Service

www.buildata.com.au

HIA (Housing Industry Association)

www.buildingonline.com.au

Master Builders Association

www.masterbuilders.com.au

Office of Fair Trading & Home Building Services

www.fairtrading.nsw.gov.au

Standards Australia

www.standards.com.au

Timber Development Association

www.timber.net.au

WERS.net - website for the Window Energy Rating Scheme (WERS)

www.wers.net