

Woak

2023

22

A melting pot DNA where skills originate from crossed cultures and combine with the woodworking tradition of the land where the raw material comes from. Woak symbolises the strength of a company and the desire to open up to the new with an almost nomad vocation to travel and absorb knowledge from all over the world and then mix it with the original heritage of craftsmanship carpentry.

Instead of products, we create "pieces", crafted with great care for the users as well the environment. We are passionate about working with the warmth of solid wood, especially oak and walnut, and attach great importance to sustainable raw materials.

Woak

BRIONI designed by Zoran Jedrejčić .
An apparently "simple" object like the chair becomes the center of meticulous design study aimed at obtaining a mix of lightness, ergonomic, iconic shape, resistance and versatility. The key factors lie not only in design but also in the search for right materials and connections.

BRIONI

22



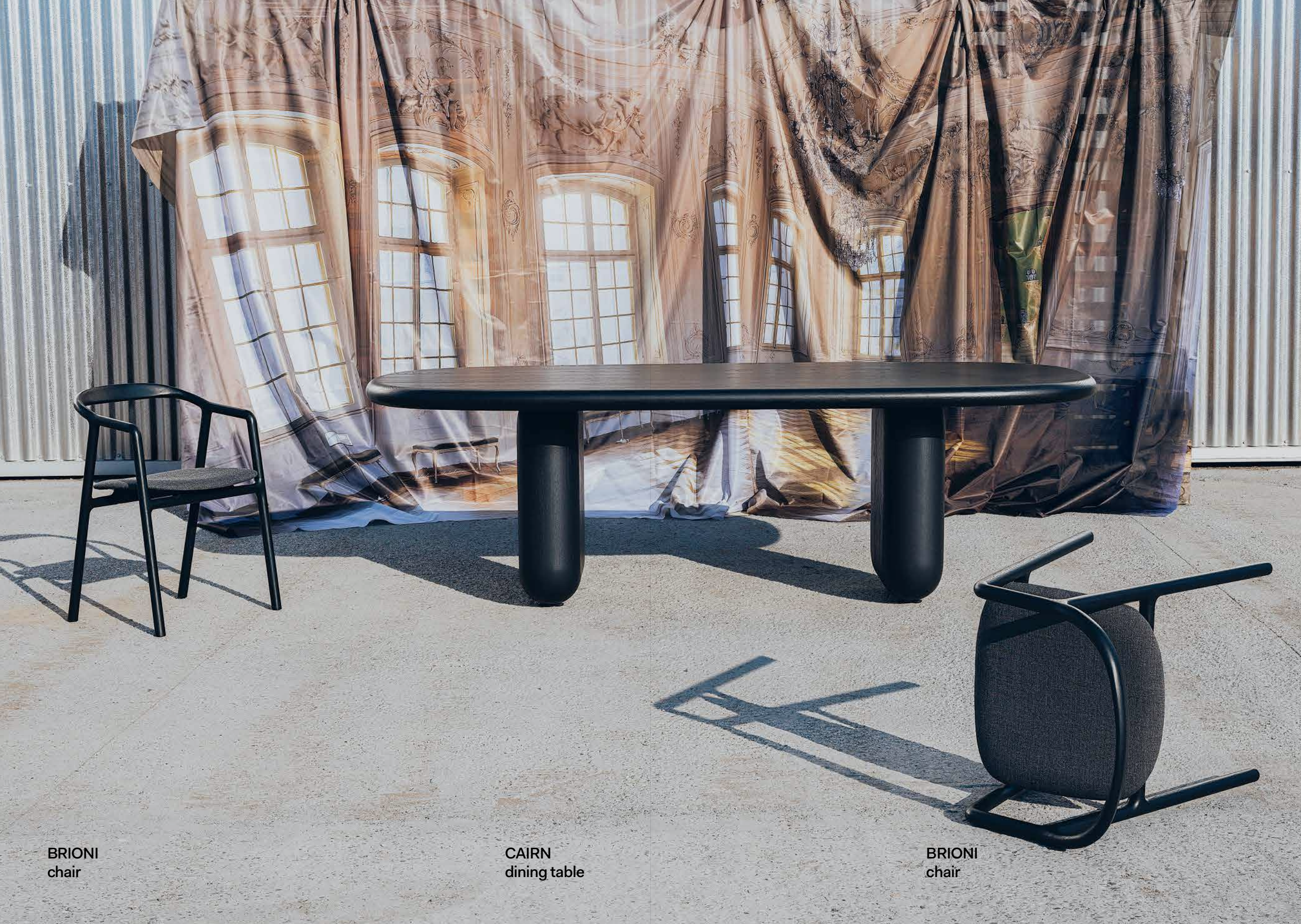

BRIONI
chair

CAIRN
dining table

BRIONI
chair



BRIONI
chair



**BRIONI
chair**

Design: Zoran Jedrejčić
Material: Walnut, oak or painted wood, fabric, leather.
Surface treatment: Lacquer or oil

Dimensions

W		D		H
53 cm	x	50 cm	x	75 cm



**BRIONI
stool**

Design: Zoran Jedrejčić
 Material: Walnut, oak or painted wood, fabric, leather.
 Surface treatment: Lacquer or oil

Dimensions

W		D		H
50 cm	x	47 cm	x	60 cm



**BRIONI
bar stool high
BRIONI
bar stool low**

Design: Zoran Jedrejčić
 Material: Walnut, oak or painted wood, fabric, leather.
 Surface treatment: Lacquer or oil

Dimensions

W		D		H
50 cm	x	49 cm	x	88 cm
50 cm	x	48 cm	x	78 cm

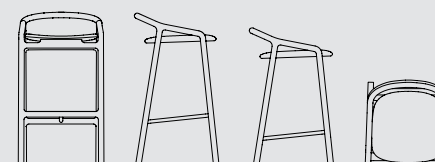



BRIONI
bar stool
high

A melting pot DNA where skills originate from crossed cultures and combine with the woodworking tradition of the land where the raw material comes from. Woak symbolises the strength of a newly independent country and the desire to open up to the new with an almost nomad vocation to travel and absorb knowledge from all over the world and then mix it with the original heritage of craftsmanship carpentry.

Instead of products, we create "pieces", crafted with great care for the users as well the environment. We are passionate about working with the warmth of solid wood, especially oak and walnut, and attach great importance to sustainable raw materials.

Designed by Zoran Jedrejčić.
Bled is a traditional Chair in the best sense of the word. With its subtle lines and compact dimensions Bled Chair is exceptionally light, both physically and visually. This simple and clean design would not compromise the harmony of any interior.

Bled Chair with its upholstered seat and pronounced armrest is suitable for frequent use in public spaces, such as restaurants, bars and hotels, but it is also perfect for private interiors.

Woak

BLED

22



BLED
chair



**BLED
chair**



**BLED
chair**

Design: Zoran Jedrejčić
Material: Walnut, oak or painted wood, Fabric, Leather
Surface treatment: Lacquer or oil

Dimensions

W		D		H
54 cm	x	53 cm	x	78 cm



BLED
chair

A meltin pot DNA where skills originate from crossed cultures and combine with the woodworking tradition of the land where the raw material comes from. Woak symbolises the strength of a company and the desire to open up to the new with an almost nomad vocation to travel and absorb knowledge from all over the world and then mix it with the original heritage of craftsmanship carpentry.

Instead of products, we create "pieces", crafted with great care for the users as well the environment. We are passionate about working with the warmth of solid wood, especially oak and walnut, and attach great importance to sustainable raw materials.

Designed by Ado Avdagić.
The main idea behind Bud was to develop a working home desk that would be versatile as much as possible utilizing natural materials while preserving warmth of home, well engineered, sustainable and finished with handcrafted know-how. The desk is made of solid wood oak and walnut as a bright and dark version, brass hinges on flaps and Kvadrat 100% wool in a range of selected colours which provide acoustic features.

Woak

BUD

22

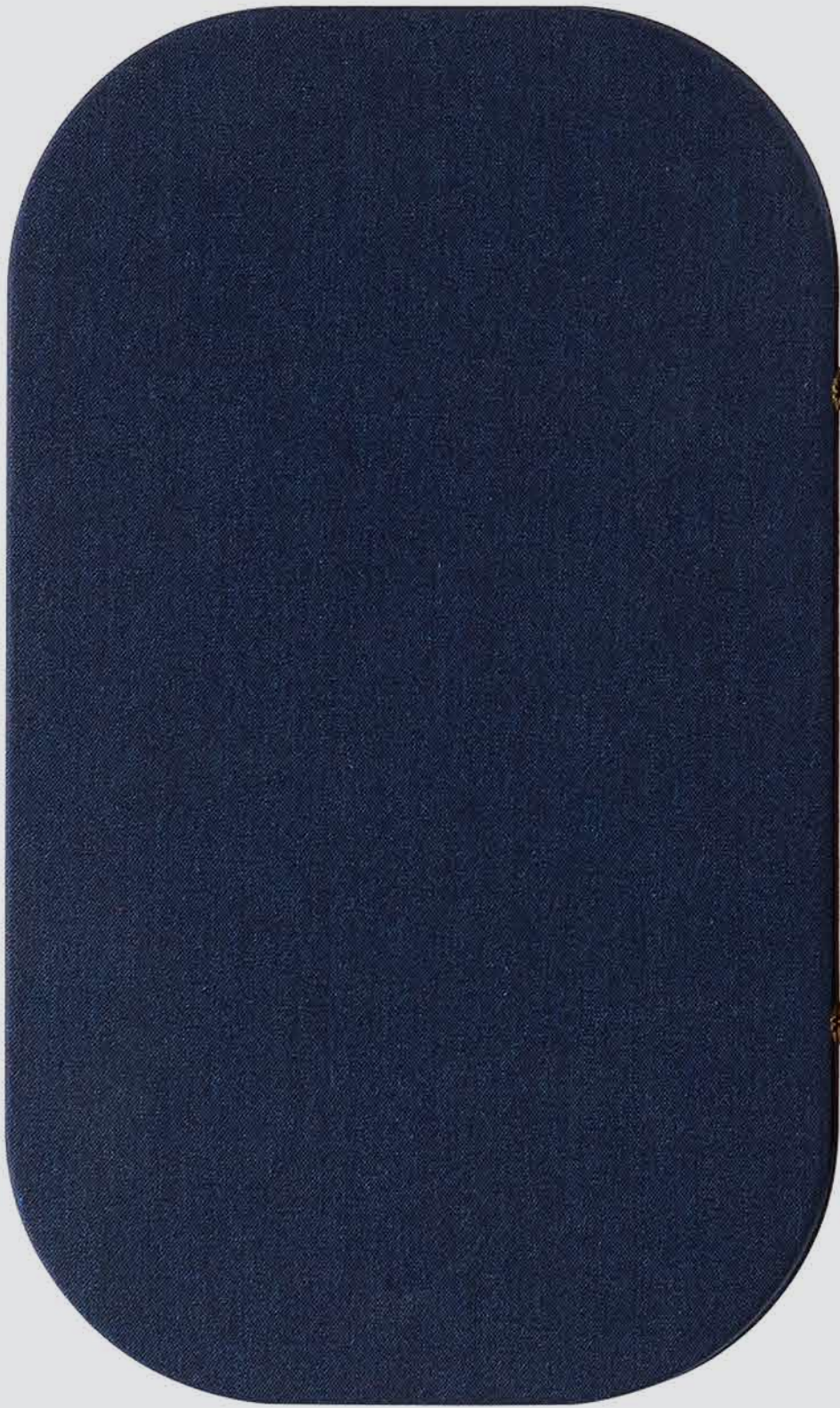

BUD
working desk



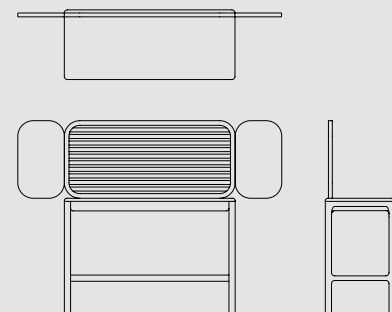

**BUD
working desk**

Design: Ado Avdagić
Material: Walnut or oak
Fabric
Surface treatment: Lacquer or oil

Dimensions

W		D		H
110 cm	x	45 cm	x	75/125 cm



BUD
working desk

A melting pot DNA where skills originate from crossed cultures and combine with the woodworking tradition of the land where the raw material comes from. Woak symbolises the strength of a company and the desire to open up to the new with an almost nomad vocation to travel and absorb knowledge from all over the world and then mix it with the original heritage of craftsmanship carpentry.

Instead of products, we create "pieces", crafted with great care for the users as well the environment. We are passionate about working with the warmth of solid wood, especially oak and walnut, and attach great importance to sustainable raw materials.

Woak

Designed by Matteo Zorzenoni.
From the idea of the unstable equilibrium of the Cairn Stones of the Zen world, Cairn is born, a table composed of two full-bodied legs and a generous top made of solid wood. All surfaces are soft and smooth, just like pebbles smoothed by the flow of water.

CAIRN

22



BRIONI
chair

CAIRN
dining table



CAIRN
dining table

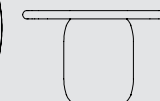
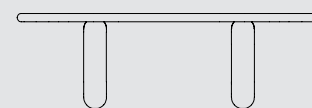

**CAIRN
dining table**

Dimensions

Design: Matteo Zorzenoni
Material: Walnut or oak
Surface treatment: Lacquer or oil

W		D		H
200 cm	x	105 cm	x	75 cm
240 cm	x	120 cm	x	75 cm
300 cm	x	120 cm	x	75 cm



CAIRN
dining table





A meltin pot DNA where skills originate from crossed cultures and combine with the woodworking tradition of the land where the raw material comes from. Woak symbolises the strength of a company and the desire to open up to the new with an almost nomad vocation to travel and absorb knowledge from all over the world and then mix it with the original heritage of craftsmanship carpentry.

Instead of products, we create "pieces", crafted with great care for the users as well the environment. We are passionate about working with the warmth of solid wood, especially oak and walnut, and attach great importance to sustainable raw materials.

Woak

CRICKET designed by Matteo Zorzenoni. Organic and soft shapes outline Cricket, a coat hanger with integrated wall mirror made of solid wood. Two elegant wooden tubes curved at the ends determine its shape, making it look like a macro ant.

CRICKET

22



BRIONI
chair

CAIRN
dining
table

CRICKET
hanger with
mirror

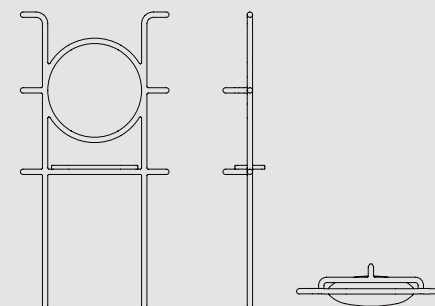
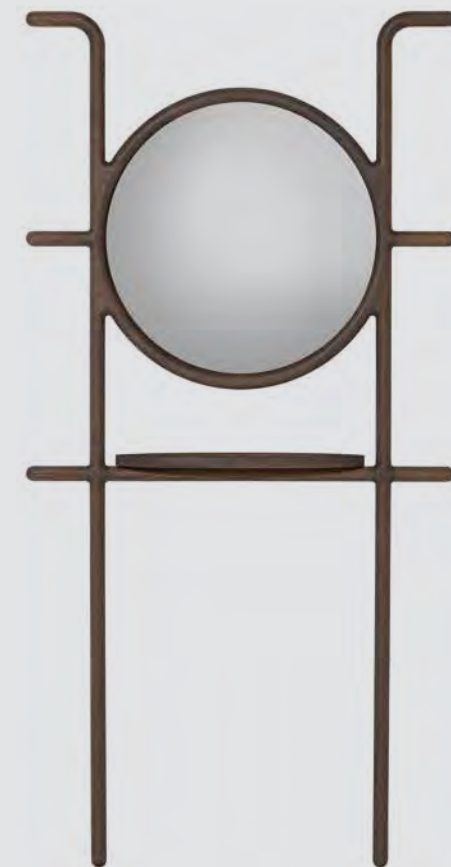

**CRICKET
hanger with
mirror**

Design: Matteo Zorzenoni
Material: Walnut or oak
Surface treatment: Lacquer or oil

Dimensions

W		D		H
98 cm	x	27,5 cm	x	195 cm
103 cm	x	27,5 cm	x	195 cm

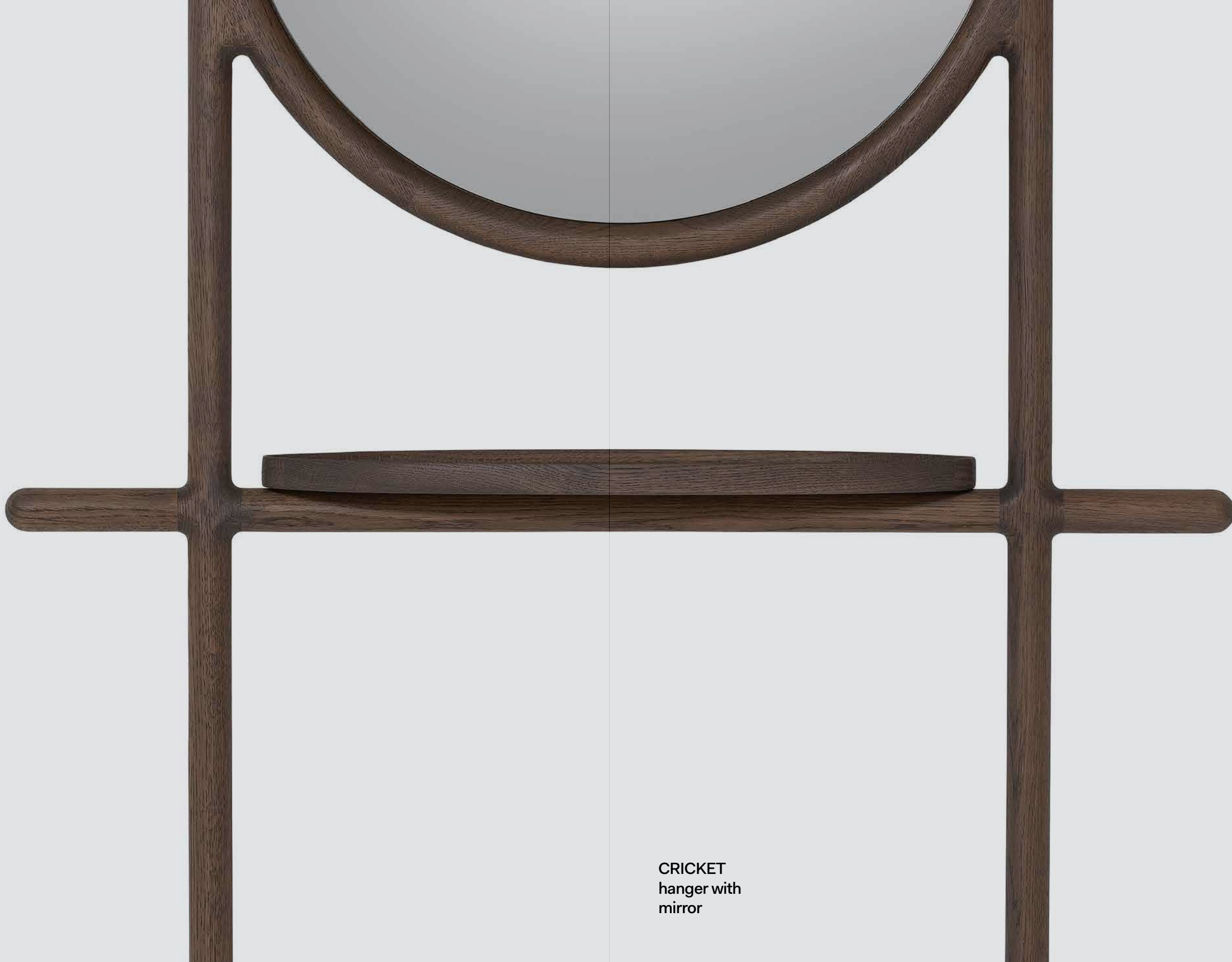

CRICKET
hanger with
mirror



CRICKET
hanger with
mirror



A melting pot DNA where skills originate from crossed cultures and combine with the woodworking tradition of the land where the raw material comes from. Woak symbolises the strength of a company and the desire to open up to the new with an almost nomad vocation to travel and absorb knowledge from all over the world and then mix it with the original heritage of craftsmanship carpentry.

Instead of products, we create "pieces", crafted with great care for the users as well the environment. We are passionate about working with the warmth of solid wood, especially oak and walnut, and attach great importance to sustainable raw materials.

Woak

Designed by Constance Guisset.
Diorama is a collection of tables to dream yourself as a curator. A crystal-clear dialog takes place between oak and glass to form a precious case with a concealed technicality. Under the guise of a cabinet of curiosities, the table invites to display treasures. An easy system of opening makes our little world close at hand.

DIORAMA

22

HAKU
console with mirror



WHERRY
Armchair



DIORAMA
coffee table

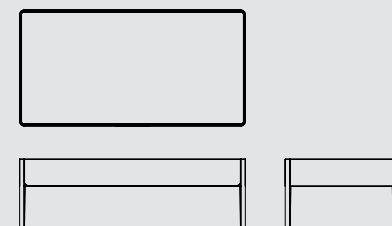
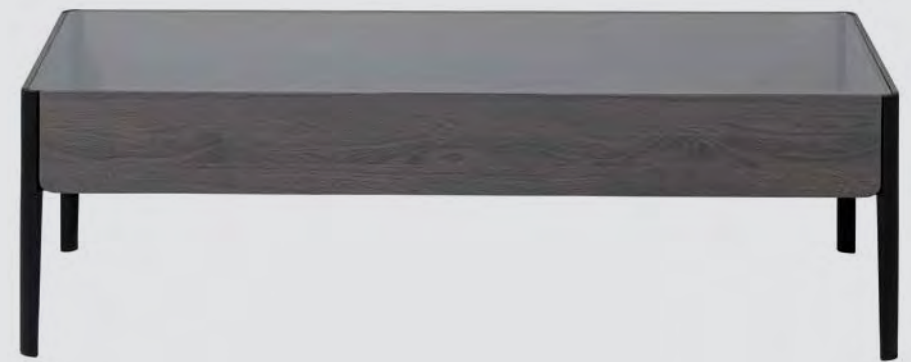

**DIORAMA
coffee table**

Design: Constance Guisset
Material: Walnut , Oak, Glass
Surface treatment: Oil

Dimensions

W		D		H
60 cm	x	40 cm	x	36 cm
70 cm	x	50 cm	x	36 cm
120 cm	x	60 cm	x	36 cm

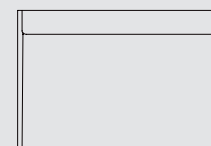
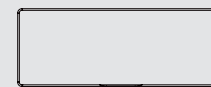
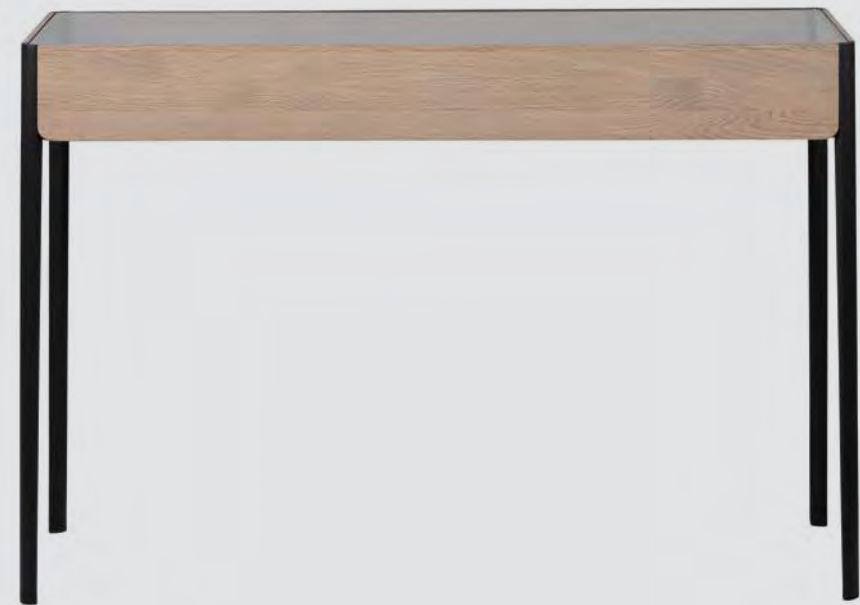

DIORAMA console

Design: Constance Guisset
Material: Walnut , Oak, Glass
Surface treatment: Oil

Dimensions

W		D		H
120 cm	x	45 cm	x	80 cm



DIORAMA
coffee table



A melting pot DNA where skills originate from crossed cultures and combine with the woodworking tradition of the land where the raw material comes from. Woak symbolises the strength of a company and the desire to open up to the new with an almost nomad vocation to travel and absorb knowledge from all over the world and then mix it with the original heritage of craftsmanship carpentry.

Instead of products, we create "pieces", crafted with great care for the users as well the environment. We are passionate about working with the warmth of solid wood, especially oak and walnut, and attach great importance to sustainable raw materials.

DUOMO Chair designed by Andrea Steidl
Duomo is a challenge of woodworking construction with such a complex exterior. It is not only a bold statement furniture piece, but also a tribute and display of excellent craftsmanship. While the chairs' straight lines and soft backrest come together in a play of contrast between massive wood and empty spaces, as you get closer you can admire the rich details of its intricate wood working.

Its vertical and straight aesthetic make it close to the vertical and detailed appearance of European Duomo, as the Milanese one, that with its impressive façade and bold presence has become an icon of the city it represents.

Woak

DUOMO

22



DUOMO
chair

DUOMO
chair





DUOMO
chair

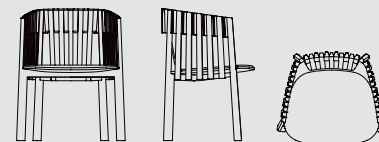

**DUOMO
chair**

Design: Andrea Steidl
Material: Walnut, oak or
painted wood
Fabric, leather
Surface treatment: Lacquer or oil

Dimensions

W		D		H
62 cm	x	53 cm	x	75 cm



DUOMO
chair



A melting pot DNA where skills originate from crossed cultures and combine with the woodworking tradition of the land where the raw material comes from. Woak symbolises the strength of a company and the desire to open up to the new with an almost nomad vocation to travel and absorb knowledge from all over the world and then mix it with the original heritage of craftsmanship carpentry.

Instead of products, we create "pieces", crafted with great care for the users as well the environment. We are passionate about working with the warmth of solid wood, especially oak and walnut, and attach great importance to sustainable raw materials.

Woak

Designed by Christophe de la Fontaine
HAKU is a severe yet articulate set of wooden cabinets, from wall-mounted to freestanding or even equipped with a mirror. Breaking the ever-present orthogonality typically found throughout ordinary box furniture, HAKU explores the principle of axial repetition. Taking advantage of its spatial perception while favouring the act of a non linear interaction.

HAKU

22



WHERRY
Armchair

DIORAMA
coffee table

HAKU
console with mirror

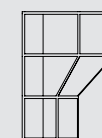
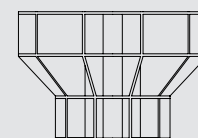
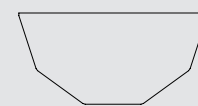

HAKU console

Design: Christophe De
La Fontaine
Material: Walnut or oak
Surface treatment: Oil

Dimensions

W		D		H
107 cm	x	52 cm	x	73.5 cm

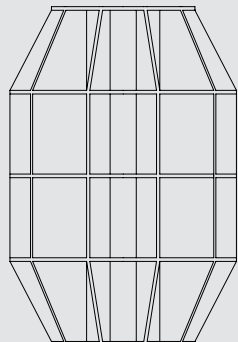
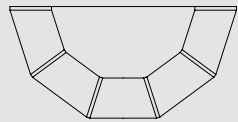

**HAKU
bookshelf**

Design: Christophe De La Fontaine
 Material: Walnut or oak
 Surface treatment: Oil

Dimensions

W		D		H
95 cm	x	46 cm	x	139,5 cm

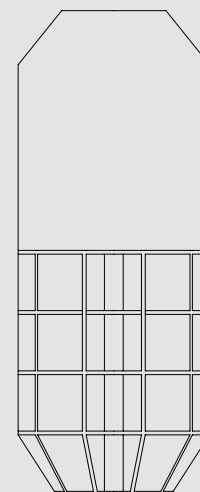
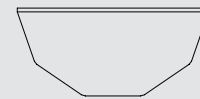

**HAKU
console
with mirror**

Design: Christophe De La Fontaine
 Material: Walnut or oak
 Mirror in Clear, Gray or Bronze
 Surface treatment: Oil

Dimensions

W		D		H
71,5 cm	x	35 cm	x	193 cm

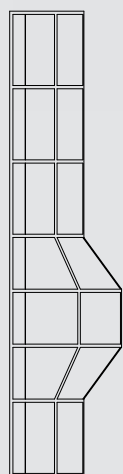
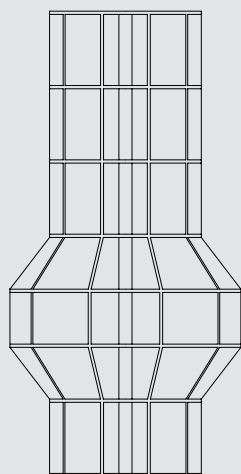
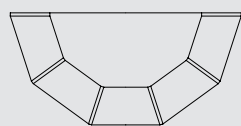

HAKU
self standing
storage

Design: Christophe De La Fontaine
Material: Walnut or oak
Surface treatment: Oil

Dimensions

W		D		H
107 cm	x	52 cm	x	216 cm





A melting pot DNA where skills originate from crossed cultures and combine with the woodworking tradition of the land where the raw material comes from. Woak symbolises the strength of a company and the desire to open up to the new with an almost nomad vocation to travel and absorb knowledge from all over the world and then mix it with the original heritage of craftsmanship carpentry.

Instead of products, we create "pieces", crafted with great care for the users as well the environment. We are passionate about working with the warmth of solid wood, especially oak and walnut, and attach great importance to sustainable raw materials.

Designed by Woak.

The soul of the collection is the fluidity of the shapes that fills each joint or intersection as if the object did not derive from the union of the components but was a single molded piece, with geometries so fluid as to seem like a printed piece. The purity of the material evokes a tactile sensation, tempting to touch those surfaces perfectly smooth to the touch but visually rich in natural veins. The organic forms call to mind the classics of Northern European cabinet-making with a reference to some iconic elements of design from the 1950s but remade in a contemporary perspective. Like the rounded corners that give a bourgeois aura and the legs that suspend the elements, putting spaces to fill, synonymous with visual comfort, in the center of the scene. In fact the collection mainly consists of cabinets and tables or in any case furniture with shelves and the imagination goes to the reassuring atmospheres of the houses of those years, however revised with a minimalist view.

Woak

MALIN

22



MALIN
shelf
system



**MALIN
shelf
system**

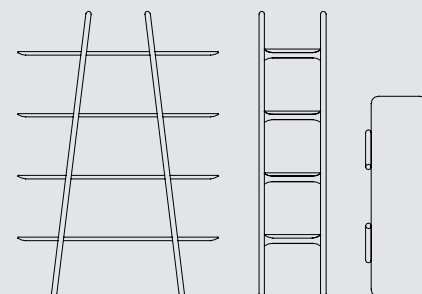

**MALIN
shelf
system**

Dimensions

Design: Woak
 Material: Walnut or oak
 Marble, Terrazzo
 Surface treatment: Oil

W		D		H
120 cm	x	40 cm	x	170 cm
120 cm	x	40 cm	x	134 cm



MALIN
working
desk

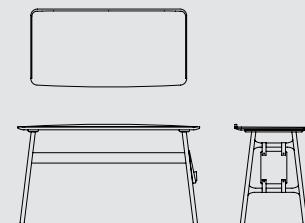

**MALIN
working
desk**

Design: Woak
Material: Walnut or oak
Leather
Surface treatment: Lacquer or oil

Dimensions

W		D		H
120 cm	x	60 cm	x	75 cm
140 cm	x	60 cm	x	75 cm

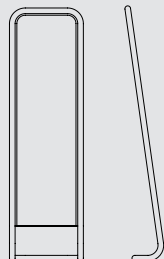

**MALIN
mirror**

Design: Woak
 Material: Walnut or oak
 Surface treatment: Oil

Dimensions

W		D		H
42 cm	x	25.5 cm	x	165 cm

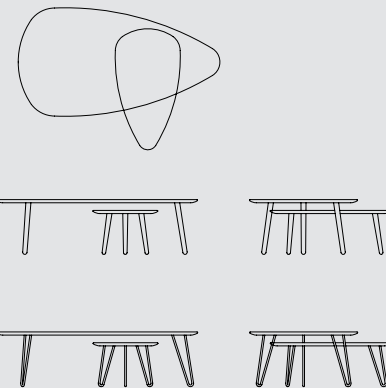

**MALIN
coffee
tables**

Design: Woak
 Material: Walnut or oak
 Surface treatment: Oil
 Option: Metal legs
 Wooden legs

Dimensions

W		D		H
140 cm	x	75 cm	x	38 cm
120 cm	x	64.5 cm	x	38 cm
84 cm	x	45 cm	x	30.5 cm



**MALIN
tv unit**

Design: Woak
 Material: Walnut or oak
 Surface treatment: Oil
 Option: Metal legs
 Wooden legs

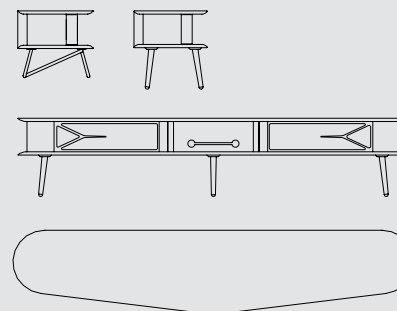

Dimensions

W		D		H
180 cm	x	45 cm	x	40/48 cm
200 cm	x	50 cm	x	40/48 cm
220 cm	x	50 cm	x	40/48 cm
240 cm	x	50 cm	x	40/48 cm



**MALIN
side table
with glass top**

Design: Woak
Material: Walnut or oak
Surface treatment: Oil

Dimensions

W		D		H
42 cm	x	42 cm	x	45 cm



**MALIN
side table
round**

Design: Woak
Material: Walnut or oak
Copper
Surface treatment: Oil

Dimensions

W		D		H
42.5 cm	x	42.5 cm	x	50 cm





MALIN
side table
round



MALIN
side table
square



MALIN
side table
square

Design: Woak
Material: Walnut or oak
Marble
Surface treatment: Oil

Dimensions

W		D		H
40 cm	x	40 cm	x	50 cm



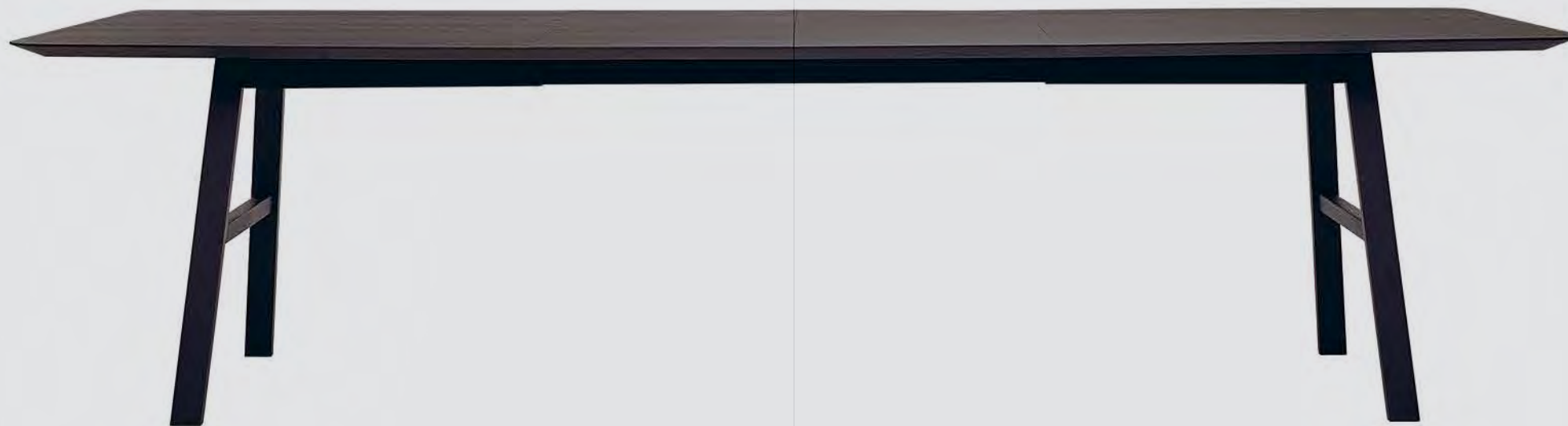

MALIN dining table

Design: Salih Teskeredžić
Material: Walnut or oak
Surface treatment: Lacquer or oil

Dimensions

W		D		H
160 cm	x	90/100 cm	x	75 cm
180 cm	x	90/100 cm	x	75 cm
Option: Extension Leaf 50 cm (1 or 2)				
200 cm	x	90 cm	x	75 cm
Option: Extension Leaf 50 cm (1 or 2)				
200 cm	x	100 cm	x	75 cm
220 cm	x	90/100 cm	x	75 cm
240 cm	x	90/100 cm	x	75 cm
300 cm	x	100 cm	x	75 cm

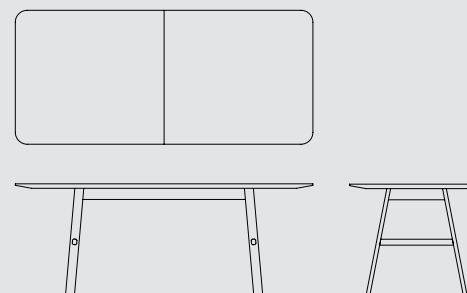



MALIN
dining table

A melting pot DNA where skills originate from crossed cultures and combine with the woodworking tradition of the land where the raw material comes from. Woak symbolises the strength of a company and the desire to open up to the new with an almost nomad vocation to travel and absorb knowledge from all over the world and then mix it with the original heritage of craftsmanship carpentry.

Instead of products, we create "pieces", crafted with great care for the users as well the environment. We are passionate about working with the warmth of solid wood, especially oak and walnut, and attach great importance to sustainable raw materials.

MARSHALL designed by Zoran Jedrejčić .
At the table, on the chair we socialise, drink, eat, tell over events and become more familiar with each other. Around this practically sacred objects, whole families and statesmen gather. Each of us in our memories carries our own table, chair, bench. It was while these memories were being played, that the Marshall Collection came about. With the Marshall Collection we carefully put in the center these memories and simple joy of life, by underlining everyday needs to touch, observe, listen, relax, enjoy, eat... The typology of chosen pieces and dialectic of the forms are simple, masculine but fluid, always in balance between thin wooden structure opposing to other natural materials carefully selected to complete each piece of the Marshall Collection such as the untreated leather, the pure marble or the cast glass with its changing colours. Those combination of hot and cold materials leads to a perfect balance not only in sight but also in touch.

Woak

MARSHALL

22



WING
coffee table

MARSHALL
lounge chair

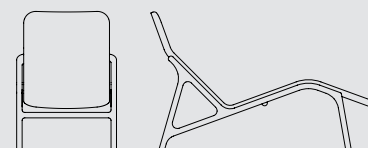
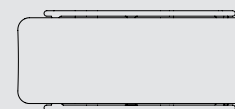

**MARSHALL
lounge
chair**

Design: Zoran Jedrejčić
Material: Walnut or oak
Leather
Surface treatment: Lacquer or oil

Dimensions

W		D		H
63 cm	x	147 cm	x	91 cm

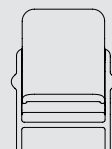
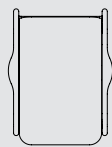

**MARSHALL
armchair
high**

Design: Zoran Jedrejčić
 Material: Walnut, oak or painted wood
 Leather
 Surface treatment: Lacquer or oil

Dimensions

W		D		H
63 cm	x	93 cm	x	96 cm

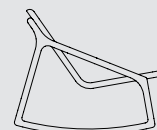
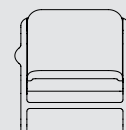
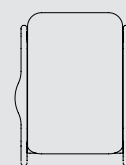

**MARSHALL
rocking
armchair**

Design: Zoran Jedrejčić
 Material: Walnut, oak or painted wood
 Leather
 Surface treatment: Lacquer or oil

Dimensions

W		D		H
69 cm	x	90 cm	x	73 cm



MARSHALL
armchair low

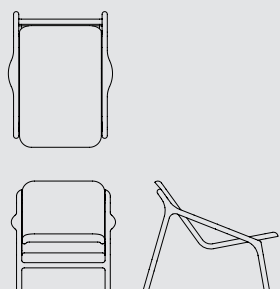

**MARSHALL
armchair
low**

Design: Zoran Jedrejčić
 Material: Walnut, oak or painted wood
 Leather
 Surface treatment: Lacquer or oil

Dimensions

W		D		H
69 cm	x	93 cm	x	73 cm



**MARSHALL
tabouret**

Design: Zoran Jedrejčić
 Material: Walnut or oak
 Leather
 Surface treatment: Lacquer or oil

Dimensions

W		D		H
55 cm	x	41.5 cm	x	40 cm



MARSHALL
chair

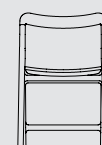
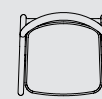

MARSHALL
chair

Design: Zoran Jedrejčić
Material: Walnut, oak or painted wood
Leather
Surface treatment: Lacquer or oil

Dimensions

W		D		H
53 cm	x	48 cm	x	78 cm

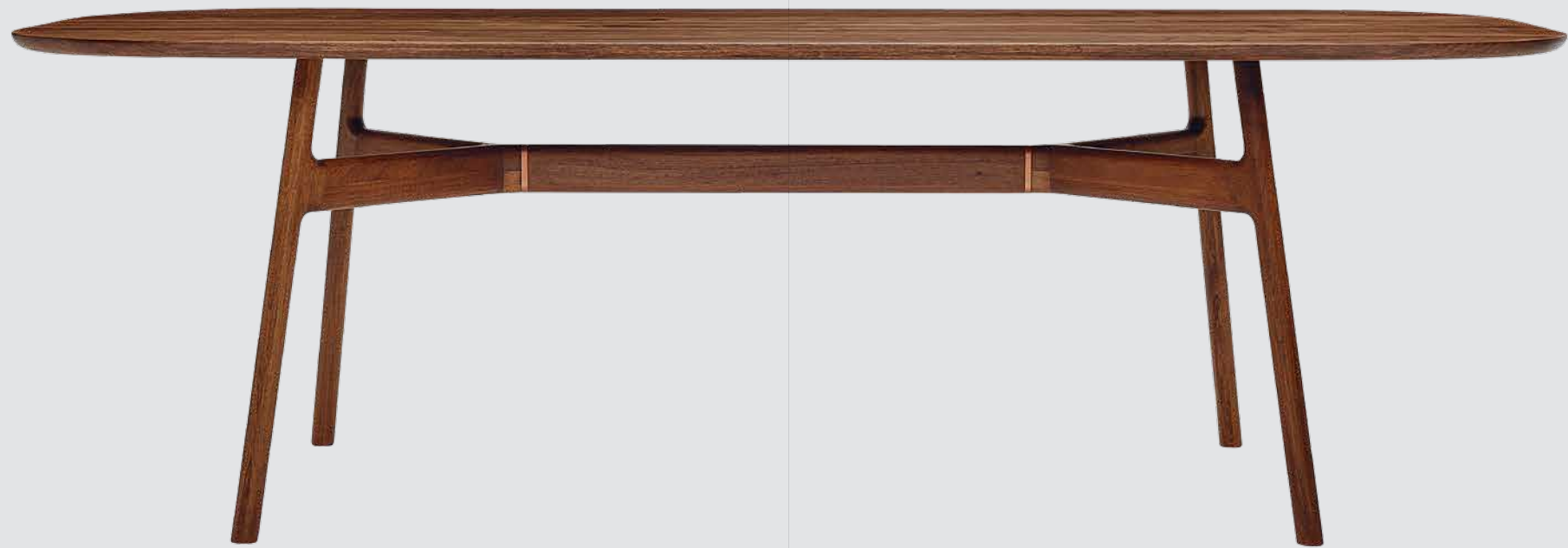

MARSHALL
dining table

Design: Zoran Jedrejčić
Material: Walnut or oak
Surface treatment: Lacquer or oil

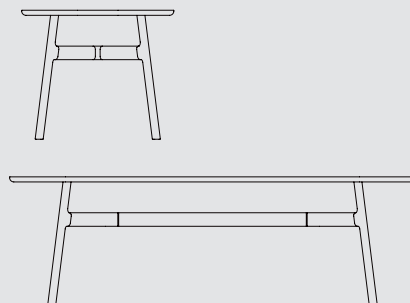

Dimensions

W		D		H
180 cm	x	90 cm	x	75 cm
200 cm	x	90 cm	x	75 cm
220 cm	x	90 cm	x	75 cm
240 cm	x	90 cm	x	75 cm
300 cm	x	90 cm	x	75 cm

W		D		H
180 cm	x	100 cm	x	75 cm
200 cm	x	100 cm	x	75 cm
220 cm	x	100 cm	x	75 cm
240 cm	x	100 cm	x	75 cm
300 cm	x	100 cm	x	75 cm



MARSHALL
dining table



MARSHALL
coffee table



**MARSHALL
coffee
table**

Design: Zoran Jedrejčić
Material: Walnut or oak
Marble
Leather
Surface treatment: Lacquer or oil

Dimensions

W		D		H
44 cm	x	44 cm	x	42.5 cm



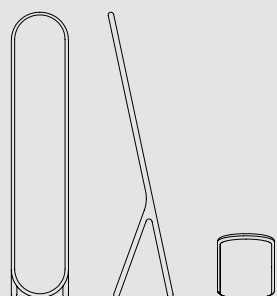

**MARSHALL
self standing
mirror**

Design: Zoran Jedrejčić
Material: Walnut or oak
Surface treatment: Lacquer or oil

Dimensions

W		D		H
33 cm	x	38 cm	x	166 cm

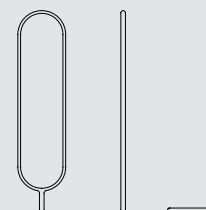

**MARSHALL
wall mirror**

Design: Zoran Jedrejčić
Material: Walnut or oak
Surface treatment: Lacquer or oil

Dimensions

W		D		H
33 cm	x	7 cm	x	140 cm
33 cm	x	7 cm	x	168 cm



**MARSHALL
ladders**

Design: Zoran Jedrejčić
 Material: Walnut or oak
 Bottom Shelf: Marble or terazzo
 Surface treatment: Lacquer or oil

Dimensions

W		D		H
40 cm	x	40 cm	x	166 cm

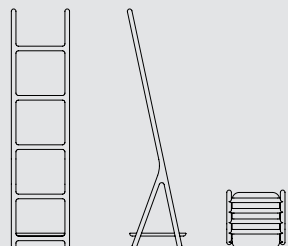



**MARSHALL
coat rail**

Design: Zoran Jedrejčić
 Material: Walnut or oak
 Bottom shelf: Marble or terazzo
 Surface treatment: Lacquer or oil

Dimensions

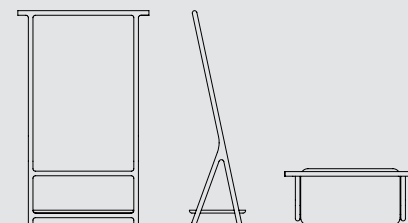
W		D		H
91 cm	x	39 cm	x	150 cm





MARSHALL
coat rail



A melting pot DNA where skills originate from crossed cultures and combine with the woodworking tradition of the land where the raw material comes from. Woak symbolises the strength of a company and the desire to open up to the new with an almost nomad vocation to travel and absorb knowledge from all over the world and then mix it with the original heritage of craftsmanship carpentry.

Instead of products, we create "pieces", crafted with great care for the users as well the environment. We are passionate about working with the warmth of solid wood, especially oak and walnut, and attach great importance to sustainable raw materials.

Designed by Simon Morasi Piperčič.
Most of the seating benches currently on the market are uncomfortable because their seating surface is flat. Therefore, we have decided to add a concave slot through the whole length of the seating surface, to make it more comfortable and allow for longer seating time. The selection of materials is quite logical, each of them is used in its most appropriate constructive purpose. The range of different finishes and colors is meant to be easily matched with any kind of contemporary residential or contract project.

Woak

MORASI

22



Morasi
bench



**Morasi
bench**

Design: Simon Morasi
Piperčić
Material: Walnut or oak
Surface treatment: Lacquer or oil

Dimensions

W		D		H
140 cm	x	36 cm	x	47 cm
160 cm	x	36 cm	x	47 cm
180 cm	x	36 cm	x	47 cm
200 cm	x	36 cm	x	47 cm
220 cm	x	36 cm	x	47 cm





Morasi
bench

A melting pot DNA where skills originate from crossed cultures and combine with the woodworking tradition of the land where the raw material comes from. Woak symbolises the strength of a company and the desire to open up to the new with an almost nomad vocation to travel and absorb knowledge from all over the world and then mix it with the original heritage of craftsmanship carpentry.

Instead of products, we create "pieces", crafted with great care for the users as well the environment. We are passionate about working with the warmth of solid wood, especially oak and walnut, and attach great importance to sustainable raw materials.

Woak

NERVOSA designed by Francesco Faccin. The project is based on traditional chairs typical of the Tyrolean and South Tyrolean area. They have a very interesting feature from a structural point of view: the seat is the key element that unites all the pieces. The "Nervosa" chair formally moves away from that typology but retains its constructive spirit while being made entirely with cnc technology. The material is entirely solid wood, which is perfect for the precision workmanship and mechanical characteristics required by this design. The chair is designed to be made of natural wood but with some aniline-treated variants that still allow the grain to show through.

NERVOSA

22



NERVOSA
chair

NERVOSA
dining
table

NERVOSA
chair with
armrest

NERVOSA
stool

HAKU
self standing
storage



NERVOSA
chair



NERVOSA
chair



NERVOSA
chair

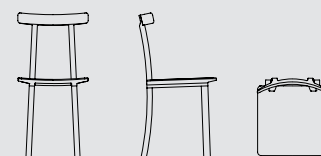

**NERVOSA
chair**

Design: Francesco Faccin
Material: Walnut, oak or
painted wood
Surface treatment: Lacquer or oil

Dimensions

W		D		H
40 cm	x	44 cm	x	83.5 cm



NERVOSA
chair

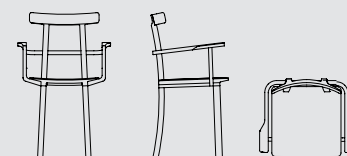

**NERVOSA
chair with
armrest**

Design: Francesco Faccin
Material: Walnut, oak or
painted wood
Surface treatment: Lacquer or oil

Dimensions

W		D		H
54 cm	x	44 cm	x	83.5 cm



NERVOSA
chair



NERVOSA
bar stool



**NERVOSA
bar stool**

Design: Francesco Faccin
Material: Walnut, oak or painted wood
Surface treatment: Lacquer or oil

Dimensions

W		D		H
40 cm	x	40 cm	x	88 cm

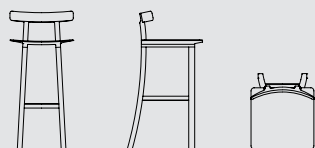

**NERVOSA
stool**

Design: Francesco Faccin
Material: Walnut, oak or painted wood
Surface treatment: Lacquer or oil

Dimensions

W		D		H
40 cm	x	40 cm	x	45 cm

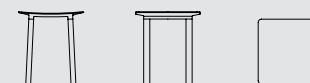



NERVOSA bench

Design: Francesco Faccin
 Material: Walnut or oak
 Surface treatment: Lacquer or oil

Dimensions

W		D		H
160 cm	x	40 cm	x	45 cm
180 cm	x	40 cm	x	45 cm
200 cm	x	40 cm	x	45 cm
220 cm	x	40 cm	x	45 cm

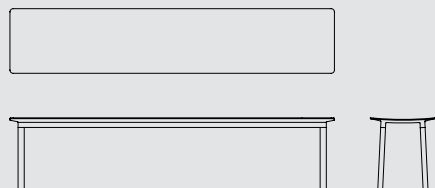

NERVOSA dining table

Design: Francesco Faccin
 Material: Walnut or oak
 Surface treatment: Lacquer or oil

Dimensions

W		D		H
180 cm	x	85 cm	x	75 cm
200 cm	x	85 cm	x	75 cm
220 cm	x	85 cm	x	75 cm
240 cm	x	90 cm	x	75 cm

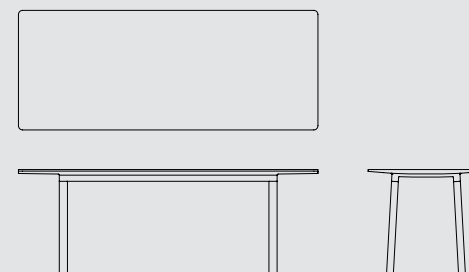



NERVOSA
dining
table



NERVOSA
chair



A melting pot DNA where skills originate from crossed cultures and combine with the woodworking tradition of the land where the raw material comes from. Woak symbolises the strength of a company and the desire to open up to the new with an almost nomad vocation to travel and absorb knowledge from all over the world and then mix it with the original heritage of craftsmanship carpentry.

Instead of products, we create "pieces", crafted with great care for the users as well the environment. We are passionate about working with the warmth of solid wood, especially oak and walnut, and attach great importance to sustainable raw materials.

Designed by Woak.

The theme is the minimalist lines applied to pieces of furniture from the past. The collection aims to offer a new interpretation of classic objects through a regeneration of the style with Woak's own processing techniques. The intent is to dismantle the common places of traditional forms, eliminating frills and elements that are too decorative to make the object contemporary and at the same time functional. Ninas consists of a console, a sidesboard and a coffee table where the clarity of the shape has been contrasted with the marble top that gives character and prestige. The dining table is an eclectic element of the collection to play with the other pieces around it.

Woak

NINAS

22



NINAS
console

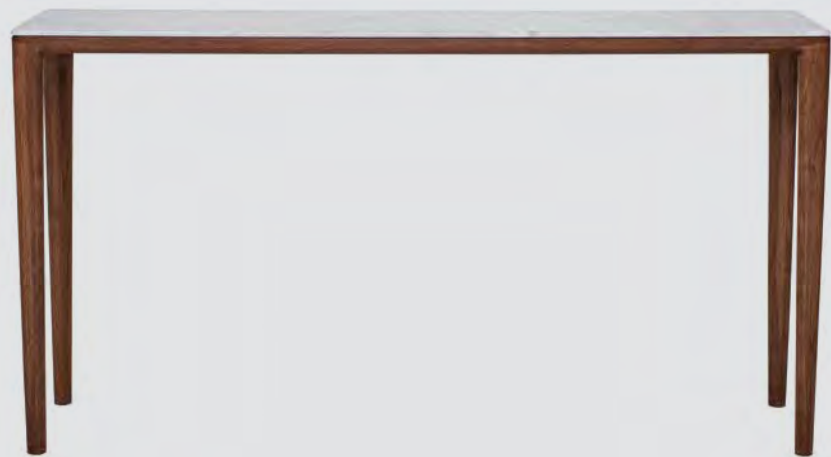

**NINAS
console**

Design: Woak
 Material: Walnut or oak
 Marble, Terrazzo
 Surface treatment: Oil

Dimensions

W		D		H
110 cm	x	35 cm	x	75 cm
140 cm	x	35 cm	x	75 cm

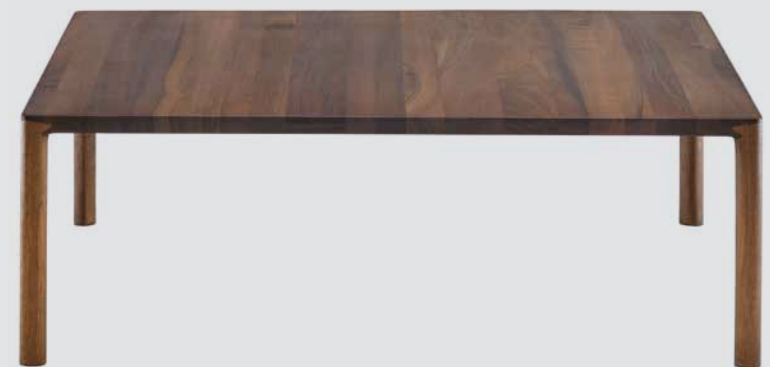
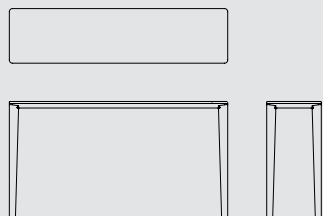

**NINAS
coffee table**

Design: Woak
 Material: Walnut or oak
 Surface treatment: Oil

Dimensions

W		D		H
45 cm	x	45 cm	x	50 cm
70 cm	x	70 cm	x	30 cm
90 cm	x	90 cm	x	30 cm
120 cm	x	55 cm	x	40 cm
140 cm	x	55 cm	x	40 cm

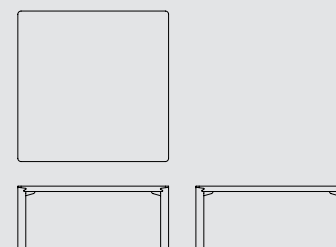

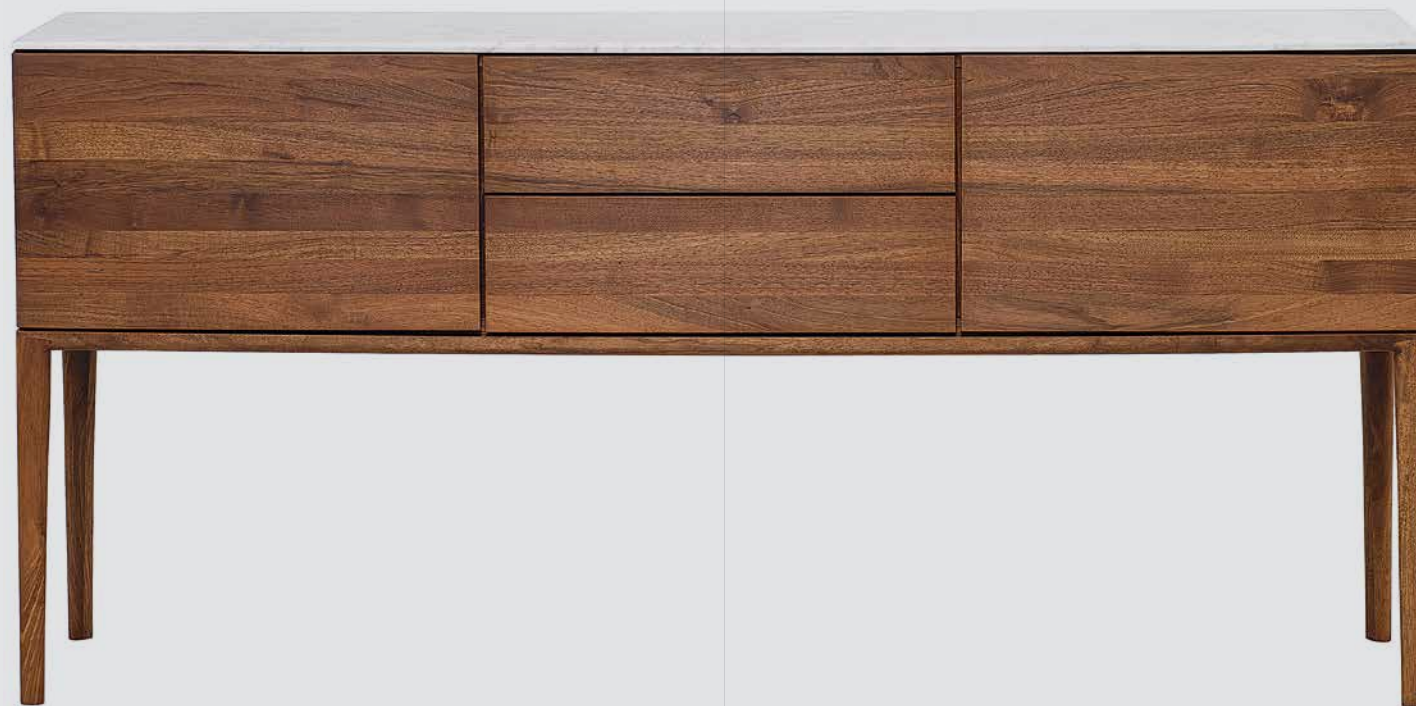

**NINAS
sideboard**

Design: Woak
 Material: Walnut or oak
 Marble, Terrazzo
 Surface treatment: Oil

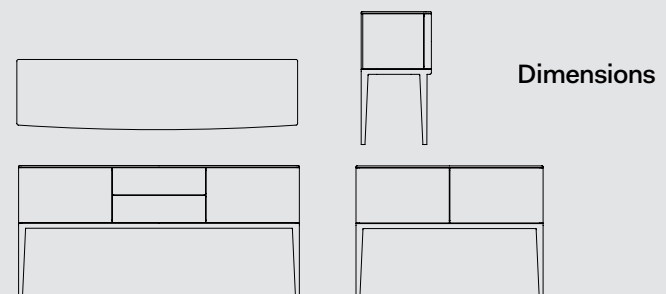

W		D		H
120 cm	x	45 cm	x	85 cm
2 doors				
120 cm	x	45 cm	x	85 cm
3 drawers				
180 cm	x	45 cm	x	85 cm
2 drawers & 2 doors				

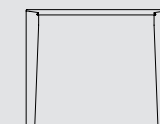
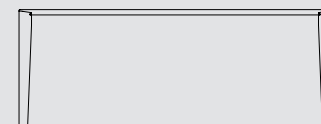
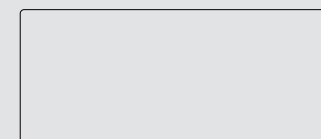
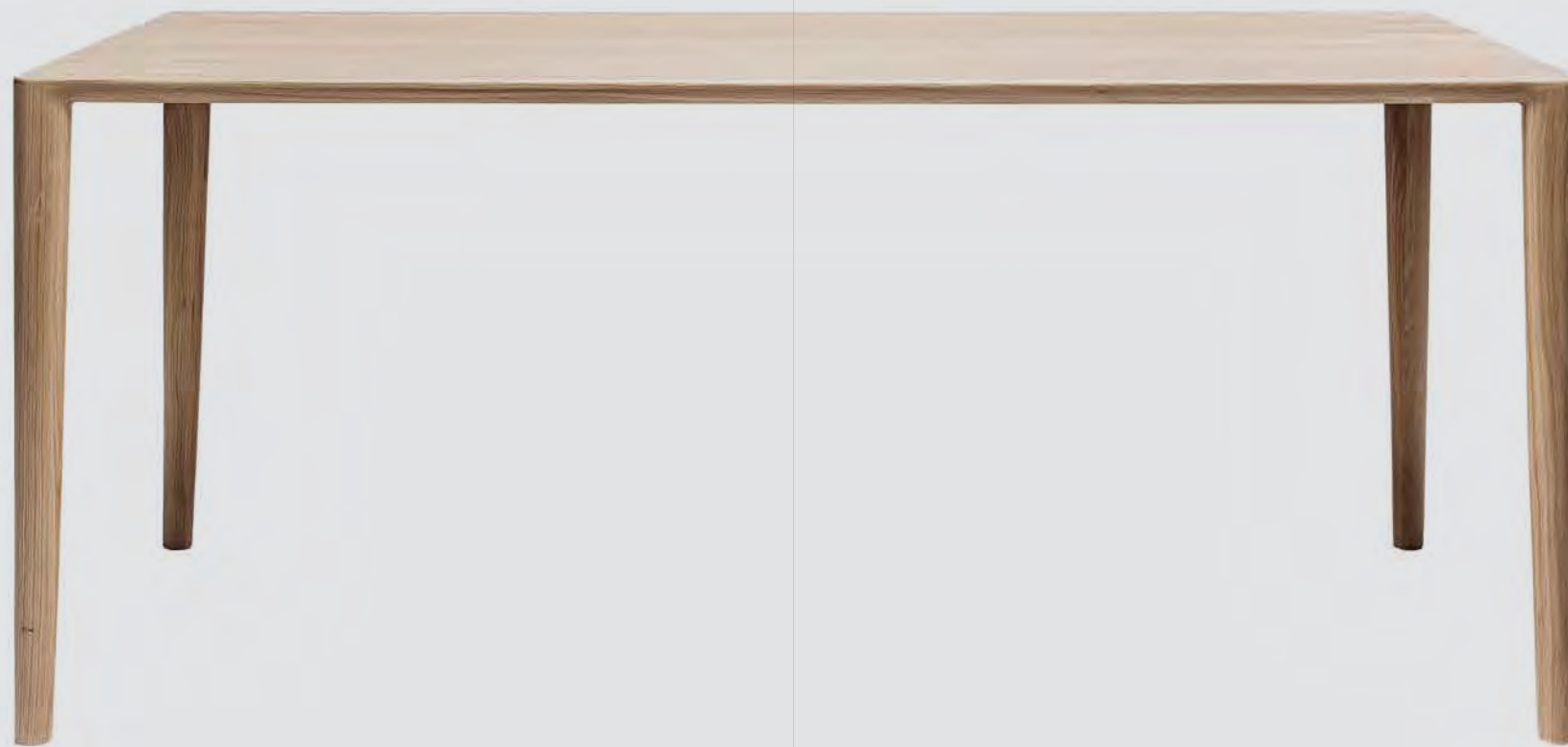

**NINAS
dining table**

Dimensions

Design: Woak
Material: Walnut or oak
Surface treatment: Oil

W		D		H
160 cm	x	90/100 cm	x	75 cm
180 cm	x	90/100 cm	x	75 cm
200 cm	x	90/100 cm	x	75 cm
220 cm	x	90/100 cm	x	75 cm



NINAS
side table

Design: Woak
Material: Walnut or oak
Marble, Terrazzo
Surface treatment: Oil

Dimensions

W		D		H
45 cm	x	45 cm	x	45 cm

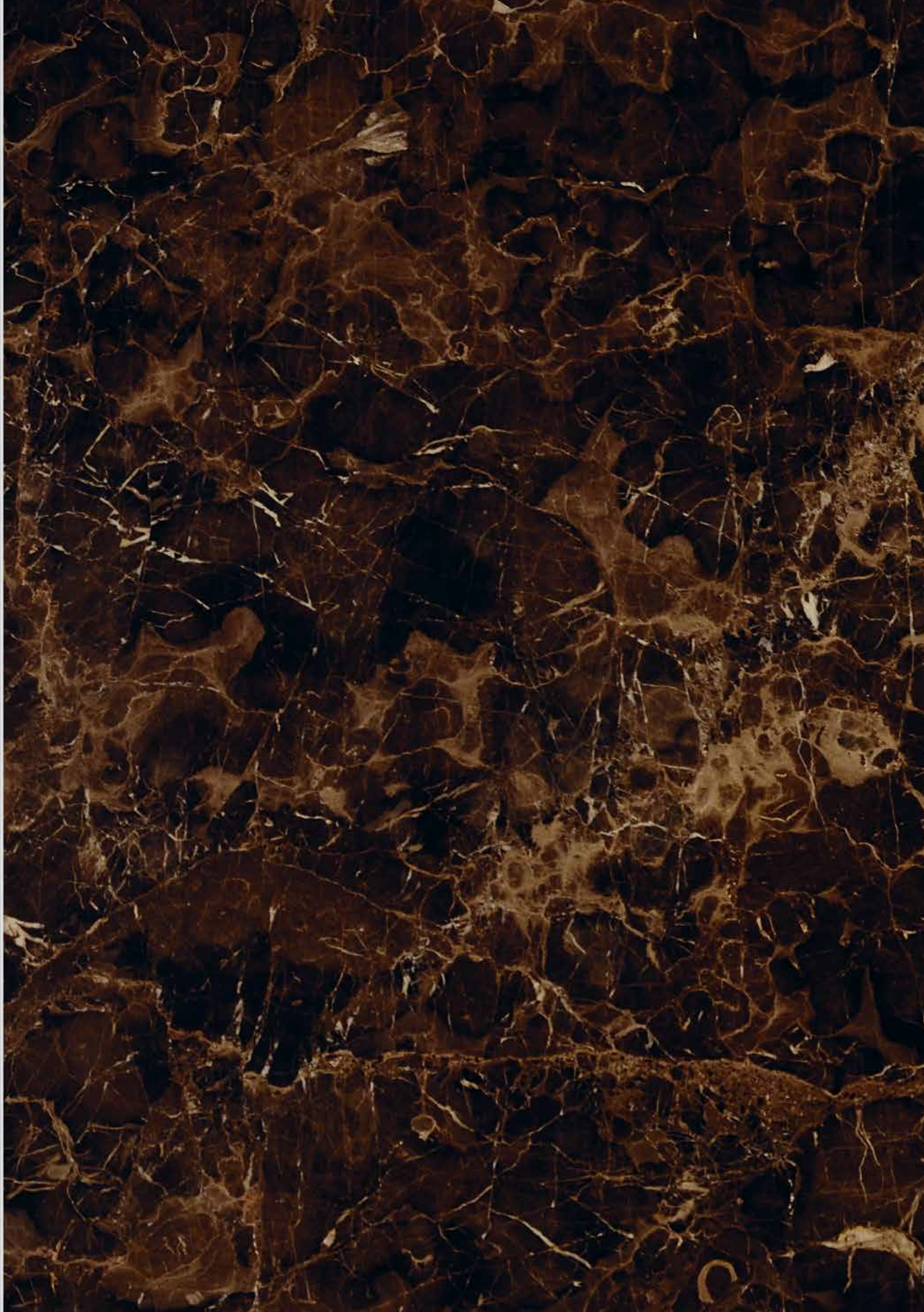

A melting pot DNA where skills originate from crossed cultures and combine with the woodworking tradition of the land where the raw material comes from. Woak symbolises the strength of a company and the desire to open up to the new with an almost nomad vocation to travel and absorb knowledge from all over the world and then mix it with the original heritage of craftsmanship carpentry.

Instead of products, we create "pieces", crafted with great care for the users as well the environment. We are passionate about working with the warmth of solid wood, especially oak and walnut, and attach great importance to sustainable raw materials.

Woak

Designed by Rainer Bachschmid.
For my dialogue with nature, wood offers the maximum potential. It is alive, mouldable, stable, sustainable and always radiates naturalness. There are only a few producers who have recognised this potential and know how to use it. That craftsmanship in handling those attributes for example is also reflected in the potential of Woak. My products made of wood should retain their natural value. Clever details highlight this expression and emphasize Woak's craftsmanship. I prefer to work with breathable oils and am fascinated by translucent colors that highlight the structure of the wood. In addition, a sensitive mix with other materials and colors creates even more expression and uniqueness.

ORGANIC

LAVADO



ORGANIC
dining table

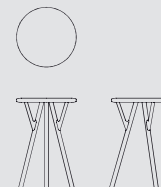

Dimensions

W	D	H
Ø 35 cm	x	x 42.5 cm
Ø 35 cm	x	x 47.5 cm
Ø 35 cm	x	x 52.5 cm



**ORGANIC
dining table**

Design: Rainer Bachschmid
Material: Walnut or oak
Surface treatment: Lacquer or oil

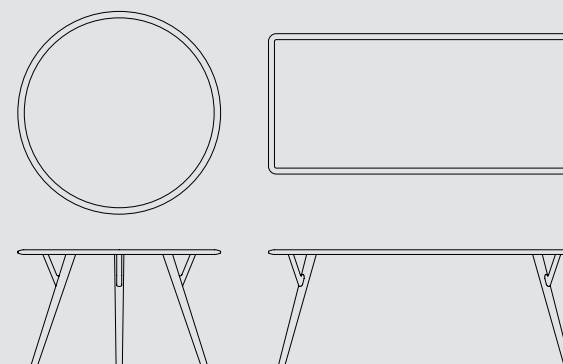

Dimensions

W		D		H
160 cm	x	90/100 cm	x	75 cm
180 cm	x	90/100cm	x	75 cm
200 cm	x	90/100 cm	x	75 cm
220 cm	x	90/100 cm	x	75 cm
240 cm	x	90/100 cm	x	75 cm
300 cm	x	100 cm	x	75 cm
Ø 130 cm			x	75 cm
Ø 150 cm			x	75 cm

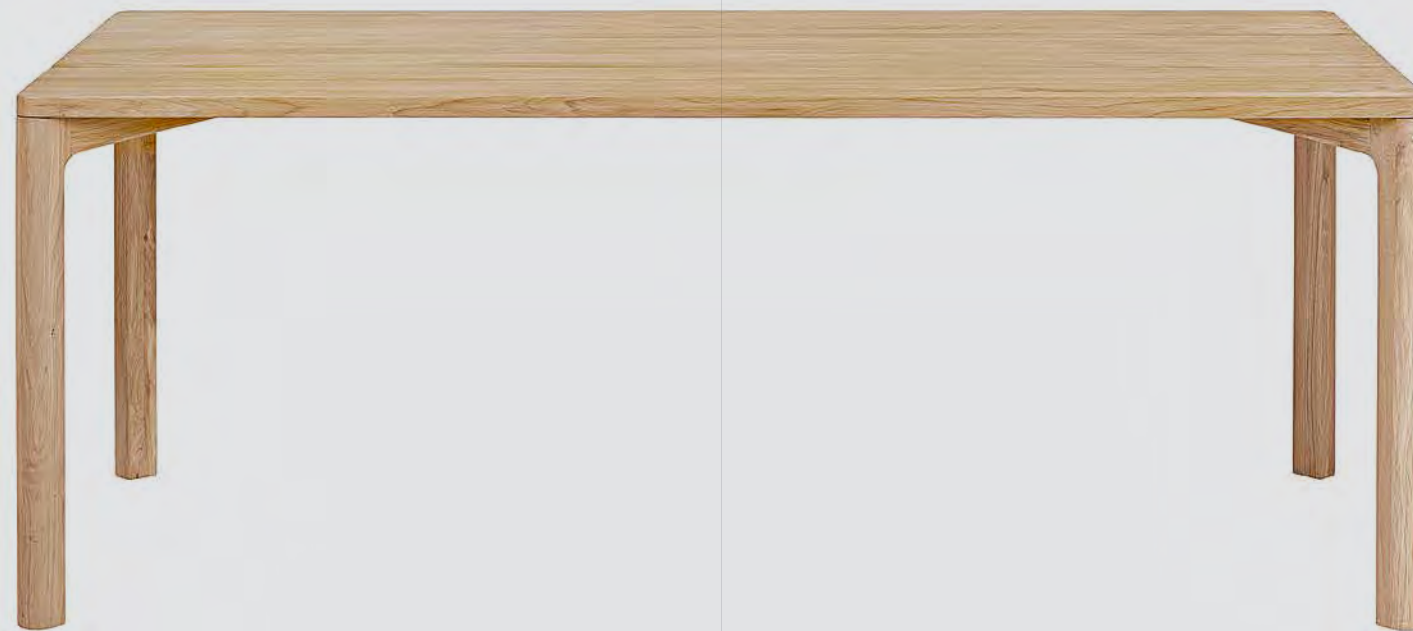

**LAVADO
dining table**

Design: Rainer Bachschmid
Material: Walnut or oak
Surface treatment: Lacquer or oil

Dimensions

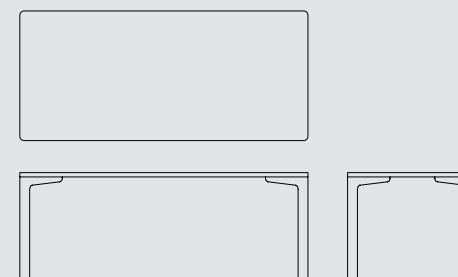

W		D		H
160 cm	x	90/100 cm	x	75 cm
180 cm	x	90/100 cm	x	75 cm
200 cm	x	90/100 cm	x	75 cm
220 cm	x	90/100 cm	x	75 cm
240 cm	x	90/100 cm	x	75 cm
300 cm	x	100 cm	x	75 cm



LAVADO
dining table

A melting pot DNA where skills originate from crossed cultures and combine with the woodworking tradition of the land where the raw material comes from. Woak symbolises the strength of a newly independent country and the desire to open up to the new with an almost nomad vocation to travel and absorb knowledge from all over the world and then mix it with the original heritage of craftsmanship carpentry.

Instead of products, we create "pieces", crafted with great care for the users as well the environment. We are passionate about working with the warmth of solid wood, especially oak and walnut, and attach great importance to sustainable raw materials.

Designed by Andrea Steidl REPETA is a symbol of the know-how and technology of Woak; their excellence in the industry of wood working. During my visit to the manufacturing facilities, I was immediately captivated by the technology and manufacturing facilities where Woak demonstrates their mastery. The industrial structure seems very efficient in which long lines of carpenters and workers transform a rough trunk by assembling perfect, linear and smooth planks into solid wood tops, dining tables or furniture; the noblest quality of wooden furniture. They are characterized by the furniture industry as well as the tradition of cabinet-making and high-quality carpentry. The combination of milling machine technology and the experience of old carpenters who have loved and cultivated woodworking for 30 years made it clear to me that narrating this process within a single product was a priority. I had to find a language

that would exploit this context and its production qualities. This is why Repeta has a strong character, it is the character and strength of the workers and of a land where solid wood has always been part of the production of quality furniture and objects. The repetition of pieces of the same shape and size for me was the mirror of the industrial repetition of a single piece which within Woak is a must to obtain a complex and uniform product of solid wood. The Repeta collection was designed to transform their industrial culture into complex furniture with a strong and unique aesthetic. The collection is composed of containers and sideboards with an assembled, faceted and grooved structure, which is very complex to make. It was just as complex to find the assembly model that must be carried out by the expert hands of the carpenters. The collection creates objects with geometric motifs declined in different shades of wood used to contain the objects of our unique passions.

Woak

REPETA

22



BRIONI
chair

WHERRY
dining table

REPETA 01
cupboard



REPETA 01
cupboard



REPETA 01
cupboard

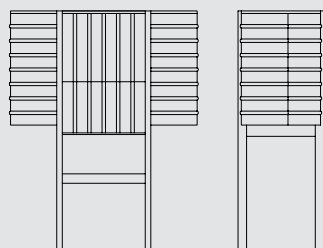

**REPETA 01
cupboard**

Design: Andrea Steidl
 Material: Walnut or oak
 Marble or Terrazzo
 Surface treatment: Oil

Dimensions

W		D		H
100 cm	x	43 cm	x	120 cm

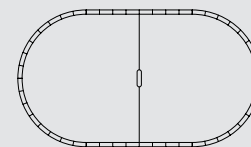

**REPETA 04
coffee table**

Design: Andrea Steidl
 Material: Walnut or oak
 Marble, Terrazzo
 or Wood
 Surface treatment: Oil

Dimensions

W		D		H
142 cm	x	80 cm	x	36 cm

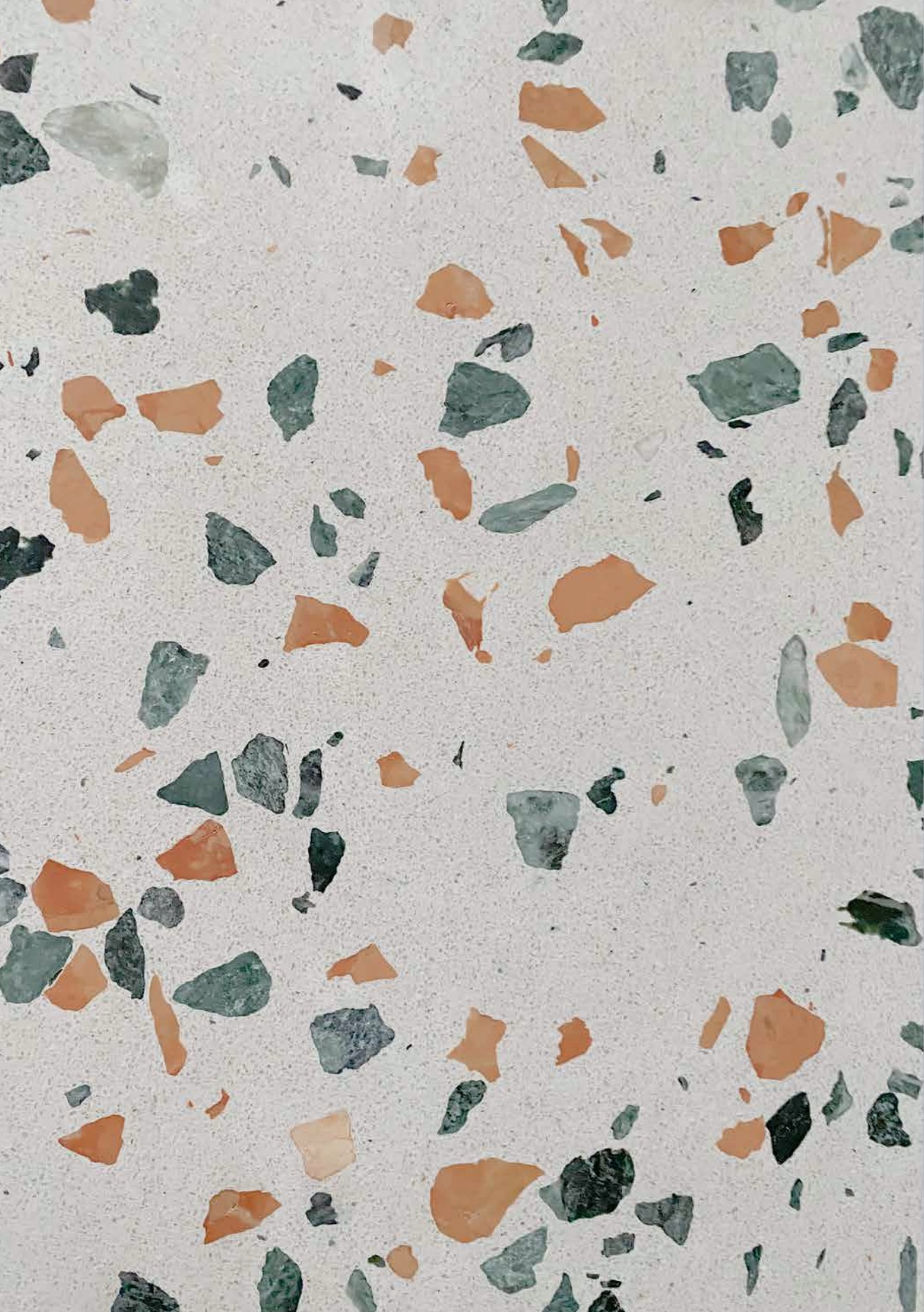

**REPETA 10
side table**

Design: Andrea Steid
Material: Walnut or oak
Copper, Marble,
Terrazzo or Wood
Surface treatment: Oil

Dimensions

W		D		H
65 cm	x	65 cm	x	36 cm

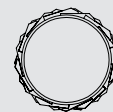

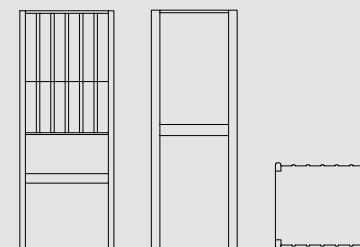

**REPETA 02
cupboard**

Design: Andrea Steidl
Material: Walnut or oak
Marble, Terrazzo
Surface treatment: Oil

Dimensions

W		D		H
51 cm	x	43 cm	x	120 cm



REPETA 03
cupboard

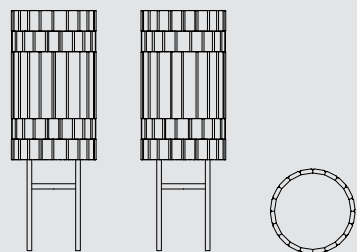

**REPETA 03
cupboard**

Design: Andrea Steidl
 Material: Walnut or oak
 Metal
 Surface treatment: Oil

Dimensions

W		D		H
50 cm	x	50 cm	x	140 cm

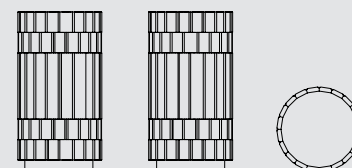

**REPETA 03
cupboard**

Design: Andrea Steid
 Material: Walnut or oak
 Metal
 Surface treatment: Oil

Dimensions

W		D		H
50 cm	x	50 cm	x	92 cm



REPETA 03
cupboard



REPETA 03
cupboard



REPETA 03
cupboard



A melting pot DNA where skills originate from crossed cultures and combine with the woodworking tradition of the land where the raw material comes from. Woak symbolises the strength of a company and the desire to open up to the new with an almost nomad vocation to travel and absorb knowledge from all over the world and then mix it with the original heritage of craftsmanship carpentry.

Instead of products, we create "pieces", crafted with great care for the users as well the environment. We are passionate about working with the warmth of solid wood, especially oak and walnut, and attach great importance to sustainable raw materials.

Designed by Matteo Zorzenoni SAGUARO is a coat hanger that acts as a functional decorative element inside the house. Made entirely of solid wood, it has four adjustable arms that, depending on the need, can modify its volume until it resembles a Cactus from which it takes its name.

Woak

SAGUARO

22



DIORAMA
console



SAGUARO
hanger



BRIONI
bar stool
high



SAGUARO
hanger

SAGUARO
hanger

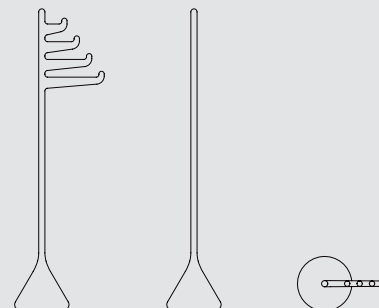

SAGUARO
hanger

Dimensions

Design: Matteo Zorzenoni
Material: Walnut or oak
Surface treatment: Lacquer or oil

W	D	H
50,5 cm	x 60 cm	x 170 cm



SAGUARO
hanger



A melting pot DNA where skills originate from crossed cultures and combine with the woodworking tradition of the land where the raw material comes from. Woak symbolises the strength of a company and the desire to open up to the new with an almost nomad vocation to travel and absorb knowledge from all over the world and then mix it with the original heritage of craftsmanship carpentry.

Instead of products, we create "pieces", crafted with great care for the users as well the environment. We are passionate about working with the warmth of solid wood, especially oak and walnut, and attach great importance to sustainable raw materials.

Designed by Isabel Ahm.
Tria is inspired by antique milking stools. Tria transforms the milking chair typology into a contemporary high quality coffee table, minimal and with a clever construction. It is made from walnut and a hand crafted glass table top. The details are tactile and invites you to touch the table. It is an inviting table, that nourishes your senses.

Woak

TRIA

22



TRIA
coffee table



TRIA
coffee table

TRIA
coffee table

Design: Isabel Ahm
Material: Walnut or oak
Table top: Parsol
Glass or Wood
Surface treatment: Oil

Dimensions

W	D	H
Ø 80 cm	x	x 42 cm

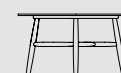
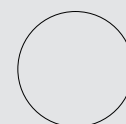



TRIA
coffee table

A melting pot DNA where skills originate from crossed cultures and combine with the woodworking tradition of the land where the raw material comes from. Woak symbolises the strength of a company and the desire to open up to the new with an almost nomad vocation to travel and absorb knowledge from all over the world and then mix it with the original heritage of craftsmanship carpentry.

Instead of products, we create "pieces", crafted with great care for the users as well the environment. We are passionate about working with the warmth of solid wood, especially oak and walnut, and attach great importance to sustainable raw materials.

Designed by Andrea Steidl WHERRY is composed of intricate rounded boards, the result of a refined artisan woodwork. It draws inspiration from the traditional English boats of the same name and the fluid shapes of their oars which, in a transitional game between the shaft and the paddle, are enriched with details. In the chair, the boards are repeated, marking the rhythm of the backrest and harmoniously enveloping those who sit down, as in traditional Windsor armchairs.

Woak

WHERRY

22



WHERRY
Chair

WING
coffee table

WHERRY
dining table



**WHERRY
Chair**

Design: Andrea Steidl
Material: Walnut, oak or painted wood
Surface treatment: Lacquer or oil

Dimensions

W		D		H
60 cm	x	55 cm	x	76 cm





**WHERRY
Armchair**

Design: Andrea Steidl
Material: Walnut, oak or painted wood
Surface treatment: Lacquer or oil

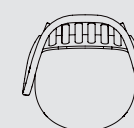
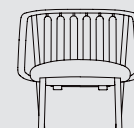

Dimensions

W		D		H
74 cm	x	69 cm	x	72 cm

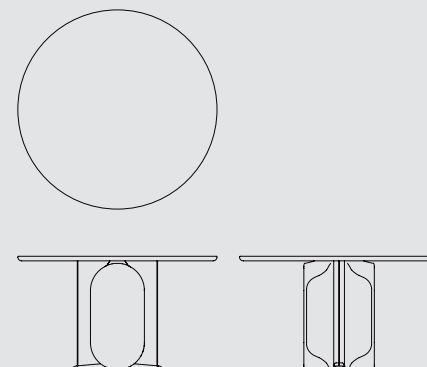

**WHERRY
dining table**

Design: Andrea Steidl
Material: Walnut, oak or painted wood legs
Surface treatment: Lacquer or oil

Dimensions

R	H
Ø 130 cm	x 75 cm



WHERRY
dining table

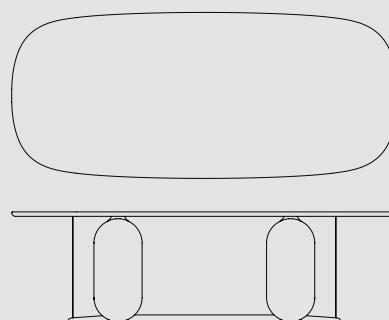

**WHERRY
dining table**

Dimensions

Design: Andrea Steidl
Material: Walnut, oak or painted wood legs
Surface treatment: Lacquer or oil

W		D		H
220 cm	x	106 cm	x	75 cm
260 cm	x	112 cm	x	75 cm
300 cm	x	112 cm	x	75 cm



WHERRY
dining table



WHERRY
dining table



A melting pot DNA where skills originate from crossed cultures and combine with the woodworking tradition of the land where the raw material comes from. Woak symbolises the strength of a company and the desire to open up to the new with an almost nomad vocation to travel and absorb knowledge from all over the world and then mix it with the original heritage of craftsmanship carpentry.

Instead of products, we create "pieces", crafted with great care for the users as well the environment. We are passionate about working with the warmth of solid wood, especially oak and walnut, and attach great importance to sustainable raw materials.

Woak

Designed by Constance Guisset WING is a collection of tables combining full lines and aerial contours. The fluid shapes draw a sculptural object, between obvious presence and lightness. The declension in four sizes and the integration of two levels let free-field to different use.

WING

22



WHERRY
Chair



WING
coffee table



WHERRY
dining table



WING
coffee table

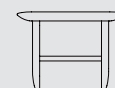
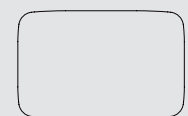

**WING
coffee table**

Design: Constance Guisset
Material: Walnut or oak
Surface treatment: Oil

Dimensions

W		D		H
70 cm	x	45 cm	x	33 cm
90 cm	x	60 cm		33 cm



WING
coffee table



WING
coffee table

Design: Constance Guisset
Material: Walnut or oak
Surface treatment: Oil

Dimensions

W		D		H
45 cm	x	45 cm	x	45 cm

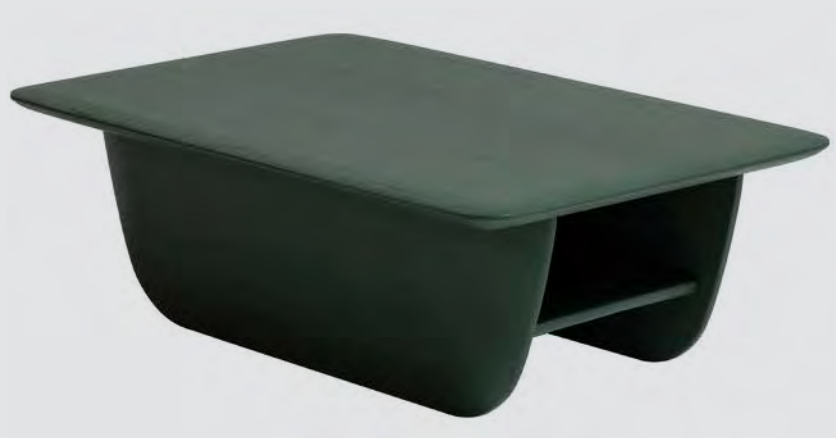

WING
coffee table

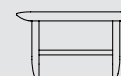
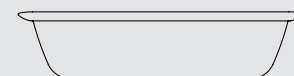
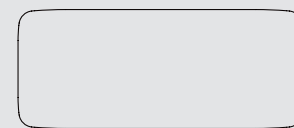

WING
coffee table

Dimensions

Design: Constance Guisset
Material: Walnut or oak
Surface treatment: Oil

W		D		H
120 cm	x	50 cm		28 cm



WING
coffee table

A melting pot DNA where skills originate from crossed cultures and combine with the woodworking tradition of the land where the raw material comes from. Woak symbolises the strength of a newly independent country and the desire to open up to the new with an almost nomad vocation to travel and absorb knowledge from all over the world and then mix it with the original heritage of craftsmanship carpentry.

Instead of products, we create “pieces”, crafted with great care for the users as well the environment. We are passionate about working with the warmth of solid wood, especially oak and walnut, and attach great importance to sustainable raw materials.

Woak

23

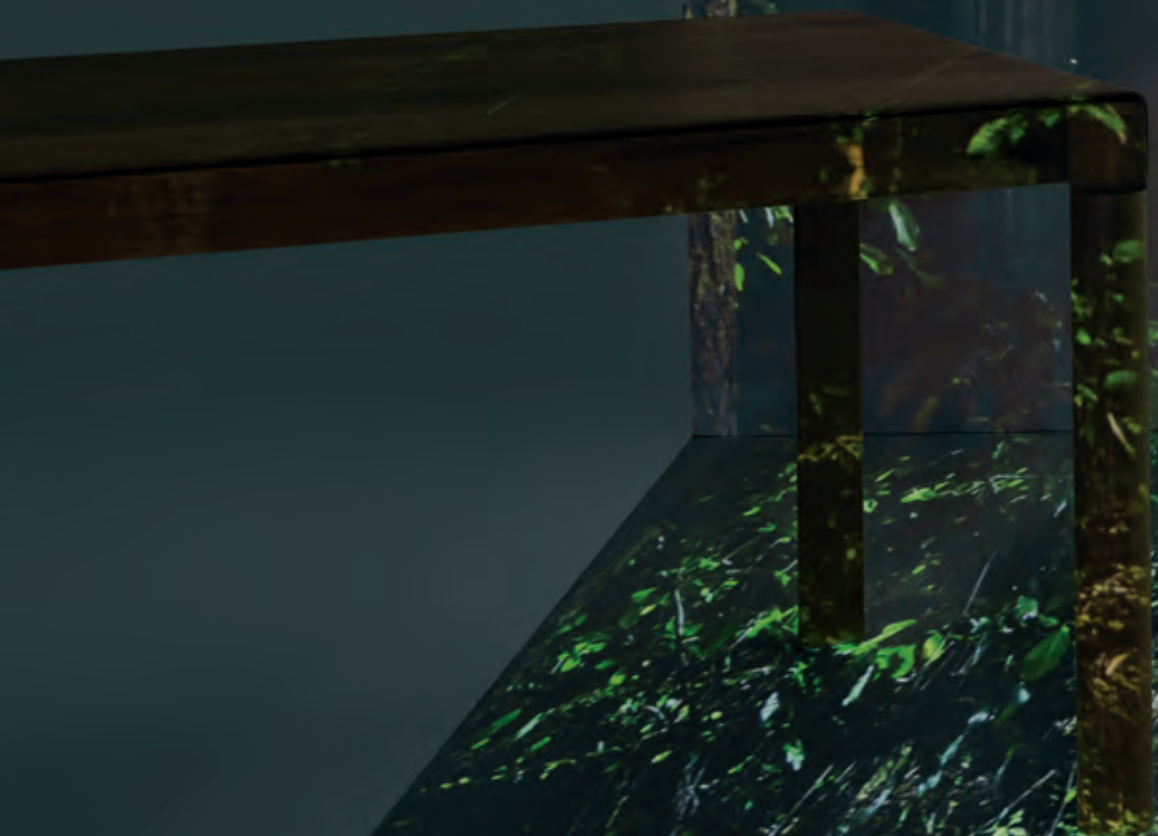

BURLY
Dining table



BURLY
Chair



WEDGED
wall wood rug



ORIGINAL
box 1

Designed by Matteo Fogale. The idea behind the pieces is to produce a familiar collection of furniture showcasing the strength and honesty of solid wood. Large sections of material are abruptly transformed into thinner sections creating a contrast of thick and thin, heavy and light. In the shelving system, different widths of vertical planes play with positive and negative space, visually heavy and light at the same time.

BURLY

23



BURLY
chair



**BURLY
chair**

Design: Matteo Fogale
 Material: Walnut, oak or beech
 Surface treatment: Lacquer or oil

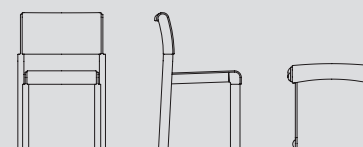

Dimensions

W		D		H
51 cm	x	50 cm	x	80 cm



BURLY
chair

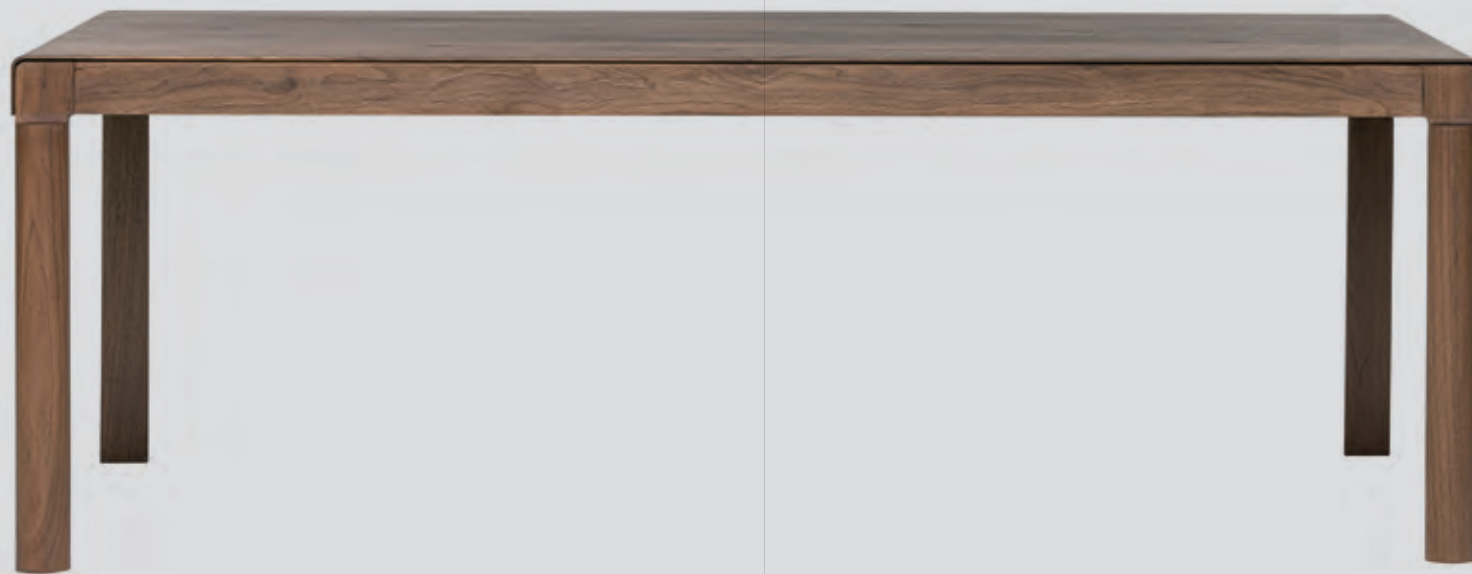

BURLY
dining table

Design: Matteo Fogale
Material: Walnut or oak
Surface treatment: Lacquer or oil

Dimensions

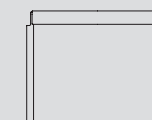
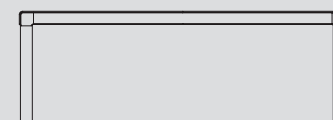
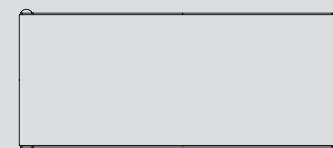

W		D		H
160 cm	x	95 cm	x	76 cm
180 cm	x	95 cm	x	76 cm
200 cm	x	95 cm	x	76 cm
220 cm	x	95 cm	x	76 cm
240 cm	x	95 cm	x	76 cm

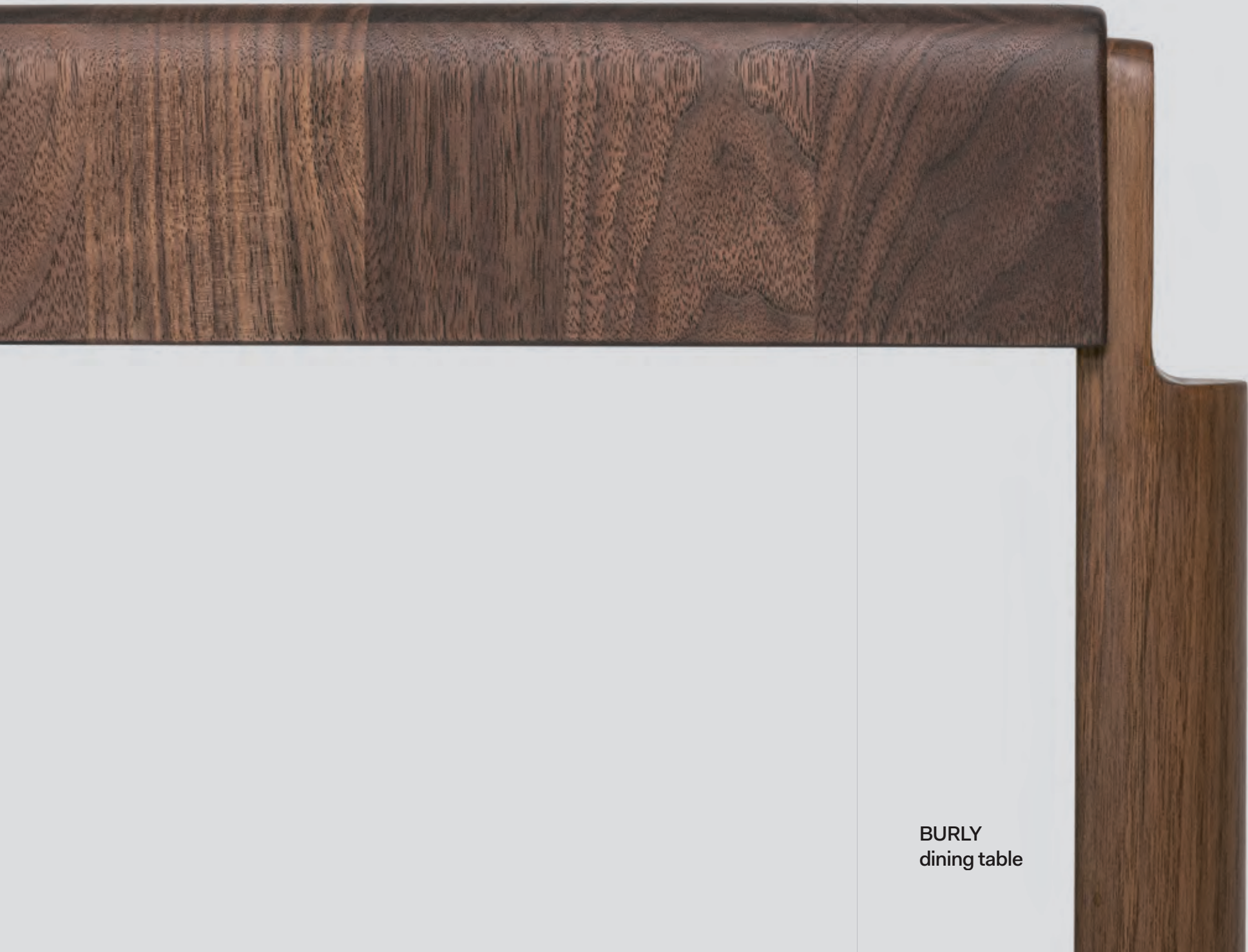

BURLY
dining table

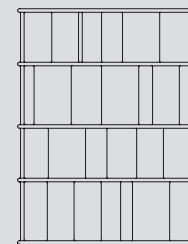
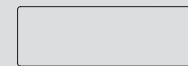

BURLY highboard

Design: Matteo Fogale
Material: Walnut or oak
Surface treatment: Oil

Dimensions

W		D		H
120 cm	x	40 cm	x	160 cm

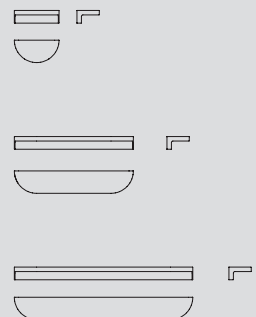

**BURLY
shelf**

Design: Matteo Fogale
 Material: Walnut or oak
 Surface treatment: Oil

Dimensions

W		D		H
30 cm	x	15 cm	x	8.5 cm
80 cm	x	15 cm	x	8.5 cm
120 cm	x	15 cm	x	8.5 cm

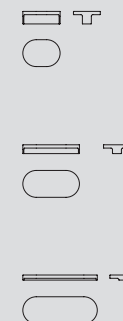

**BURLY
tray**

Design: Matteo Fogale
 Material: Walnut or oak
 Surface treatment: Oil

Dimensions

W		D		H
25 cm	x	18 cm	x	8.4 cm
38 cm	x	18 cm	x	5.9 cm
50 cm	x	18 cm	x	3.4 cm



BURLY
tray

Designed by Zoran Jedrejčić.
A new dining table completes the Brioni collection and like the rest of the family, it is geometrically determined by straight, clean lines and surfaces with slightly curved corners and joints. It exudes stability and its form and proportions seattle in our memories. Brioni table is detachable, crafted with great care for the final users and environment and suitable for home and contract use.

BRIONI

23

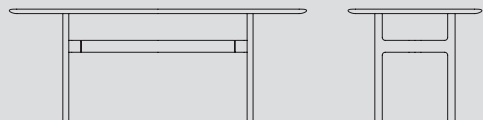
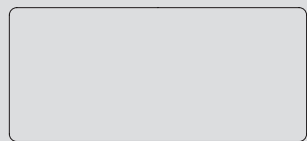
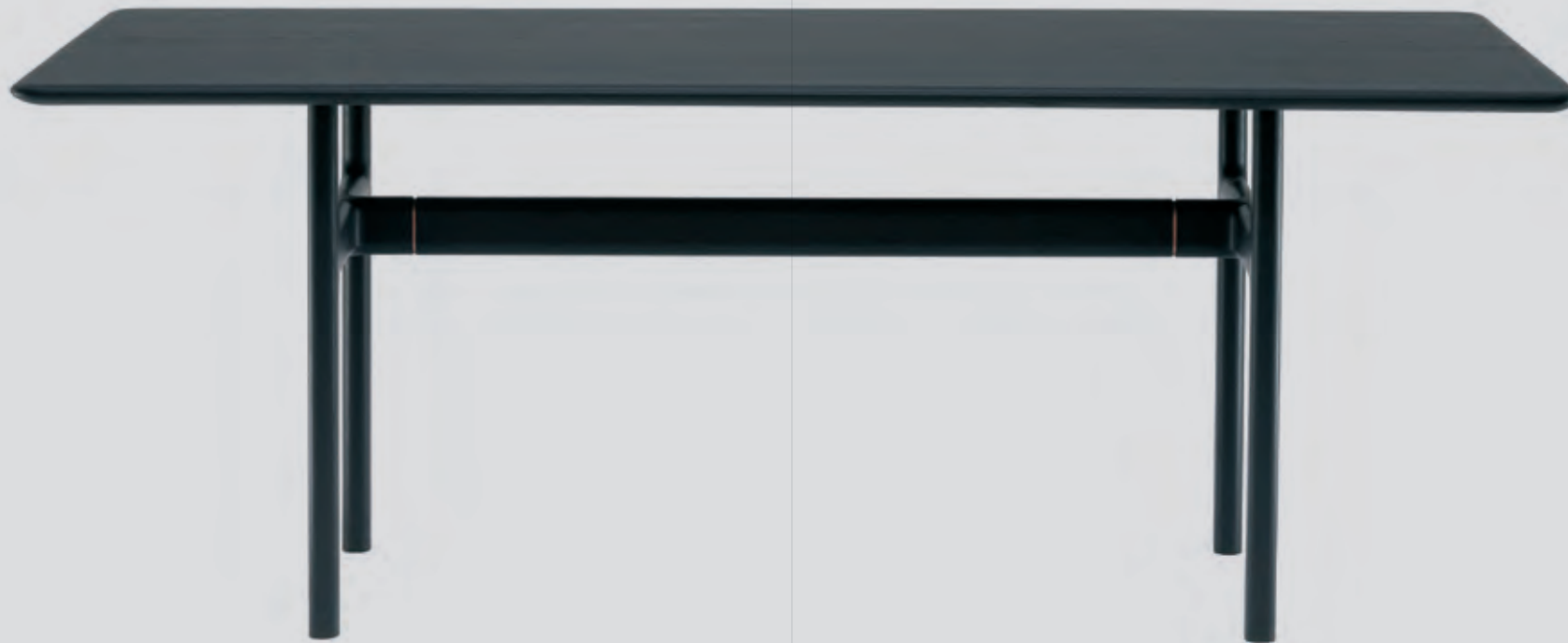

BRIONI
dining table

Design: Zoran Jedrejčić
Material: Walnut or oak
Surface treatment: Lacquer or oil

Dimensions

W		D		H
160 cm	x	90 cm	x	75 cm
180 cm	x	90 cm	x	75 cm
200 cm	x	90 cm	x	75 cm
220 cm	x	90 cm	x	75 cm
240 cm	x	90 cm	x	75 cm

W		D		H
160 cm	x	100 cm	x	75 cm
180 cm	x	100 cm	x	75 cm
200 cm	x	100 cm	x	75 cm
220 cm	x	100 cm	x	75 cm
240 cm	x	100 cm	x	75 cm
300 cm	x	100 cm	x	75 cm



BRIONI
dining table

Designed by Zoran Jedrejčić.
The idea behind Galeb corner storage system is to use all those underrated spaces like corners and angles to give them another life and meaning. Galeb transforms any corner in your public or private space into "art corner" to collect favorite books, objects, wines, or just let the children put their favorite toys.

GALEB

23



SAGUARO
hanger

GALEB
Corner Storage System

GINCANA
tray nuts

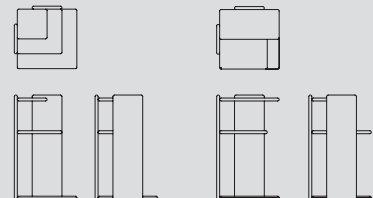

GALEB
corner storage
system / low

Dimensions

Design: Zoran Jedrejčić
Material: Walnut or oak
Surface treatment: Oil

W		D		H
42 cm	x	42 cm	x	71 cm

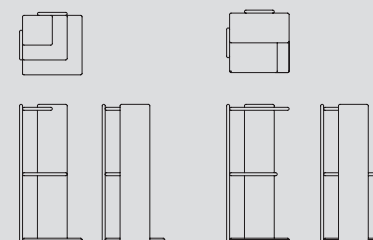

GALEB
corner storage
system / medium

Dimensions

Design: Zoran Jedrejčić
Material: Walnut or oak
Surface treatment: Oil

W		D		H
42 cm	x	42 cm	x	93 cm



GALEB
corner storage
system / low

Designed by Matteo Zorzenoni, Gincana is a collection of modular fruit bowls made of solid oak wood painted in different colours.

Thanks to the grooves, it can accommodate different types of fruit and become a fun table decoration with different form combinations.

GINCANA

23



GINCANA
tray nuts

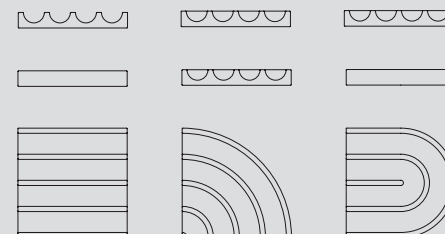

**GINCANA
tray nuts 3**

Design: Matteo Zorzenoni
 Material: Walnut or oak
 Surface treatment: Oil

Dimensions

W		D		H
18 cm	x	18 cm	x	3 cm

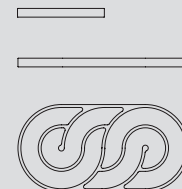

**GINCANA
fruit trays 1**

Design: Matteo Zorzenoni
 Material: Walnut or oak
 Surface treatment: Oil

Dimensions

W		D		H
51 cm	x	26 cm	x	3 cm

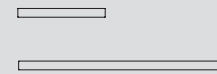

**GINCANA
fruit trays 2**

Design: Matteo Zorzenoni
Material: Walnut or oak
Surface treatment: Oil

Dimensions

W		D		H
62 cm	x	26 cm	x	3 cm

Designed by Cristophe De La Fontaine, Haku-Mini is a set of wooden centrepieces that capture the essence of their larger cabinet counterparts. Inspired by architectural models, Mini-Haku features the same unique design principle of axial repetition as the original Haku. The result is a set of centrepieces that break away from the ordinary and challenge conventional norms with their subtle yet distinctive presence. Whether used as a tray, pedestal or basket, Mini-Haku's structure invites to experience in what way objects can interact with those miniatures.

HAKU MINI

23



LEPIDA
chair
without
armrest



HAKU MINI
x, y, z



BRIONI
dining table



HAKU MINI
x, y, z

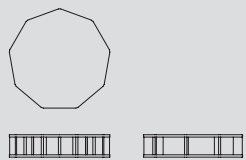

**HAKU MINI
Z**

Design: Cristophe De La Fontaine
 Material: Walnut or oak
 Surface treatment: Oil

Dimensions

W	D	H
34 cm	x 34 cm	x 8 cm

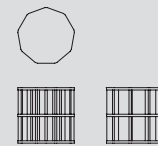

**HAKU MINI
X**

Design: Cristophe De La Fontaine
 Material: Walnut or oak
 Surface treatment: Oil

Dimensions

W	D	H
19 cm	x 19 cm	x 19 cm

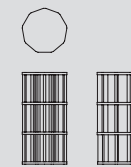

**HAKU MINI
Y**

Design: Cristophe De La Fontaine
 Material: Walnut or oak
 Surface treatment: Oil

Dimensions

W	D	H
15 cm	x 15 cm	x 31 cm

Designed by Constance Guisset Lepida is a collection of chair and armchair made of solid wood. Their organic shapes unfold from the feet to form an elegant and comfortable sculpture. The two parts of the backrest reach each other without touching. They remind of petals as well as solid wooden paddles, or even of soft shoulder blades of an exoskeleton. A delicate piece connects them in a point, like a couture detail.

LEPIDA

23



BURLY
highboard



ORIGINAL
dome
coffret

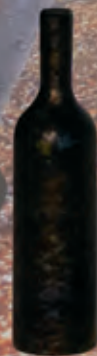

ORIGINAL
bottle
rolling pin



LEPIDA
chair



LEPIDA
chair
without
armrest



**LEPIDA
chair
without
armrest**

Design: Constance Guisset
Material: Walnut, oak or beech
Surface treatment: Lacquer or oil

Dimensions

W		D		H
44 cm	x	48 cm	x	76 cm



**LEPIDA
chair**

Design: Constance Guisset
Material: Walnut, oak or beech
Surface treatment: Lacquer or oil

Dimensions

W		D		H
60 cm	x	51 cm	x	78 cm





LEPIDA
chair

Designed by Peter Gregson
The original collection
was inspired by one
ordinary shipping box, an
extraordinary bottle of wine,
a homemade lemon cake, a
hundredsomething grams of
the finest chocolate, spicy
cookies from somewhere and
flatless flame from scented
candle.

ORIGINAL

23



ORIGINAL
cup squizer



ORIGINAL
rolling pin
bottle



ORIGINAL
table box



ORIGINAL
tray box



ORIGINAL
table box

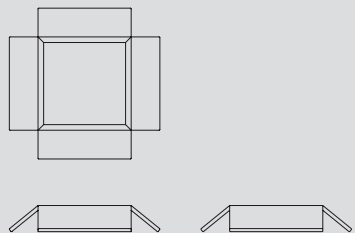
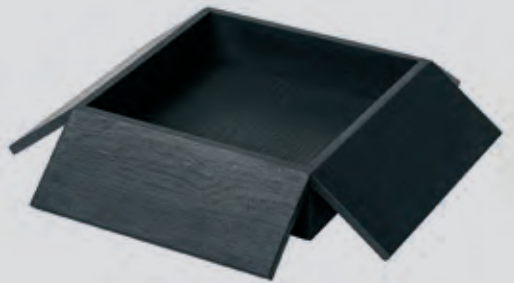

**ORIGINAL
tray box**

Design: Peter Gregson
 Material: Walnut or oak
 Surface treatment: Oil

Dimensions

W		D		H
40 cm	x	40 cm	x	7 cm

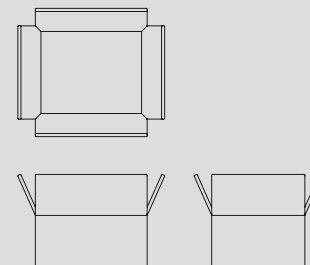

**ORIGINAL
table box**

Design: Peter Gregson
 Material: Walnut or oak
 Surface treatment: Oil

Dimensions

W		D		H
40 cm	x	34 cm	x	25 cm



**ORIGINAL
board in
tray $\frac{1}{2}$**

Design: Peter Gregson
Material: Walnut or oak
Surface treatment: Oil

Dimensions

W		D		H
26 cm	x	10 cm	x	1 cm
26 cm	x	21 cm	x	1 cm

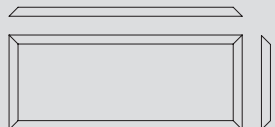

**ORIGINAL
board in
tray**

Design: Peter Gregson
Material: Walnut or oak
Surface treatment: Oil

Dimensions

W		D		H
26 cm	x	10 cm	x	2 cm
26 cm	x	21 cm	x	2 cm

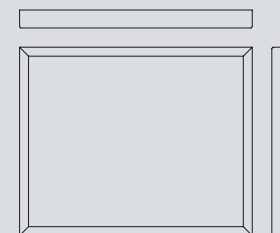

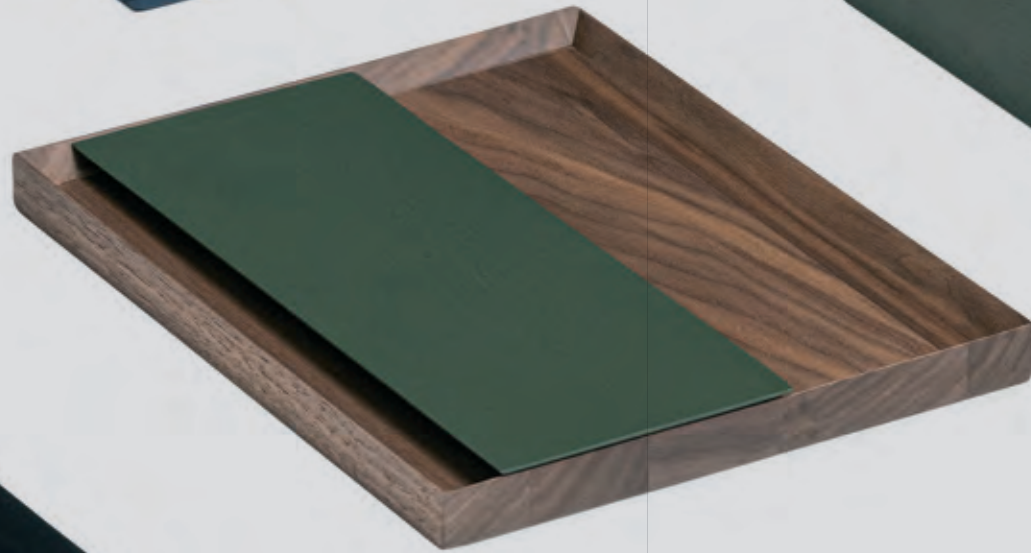
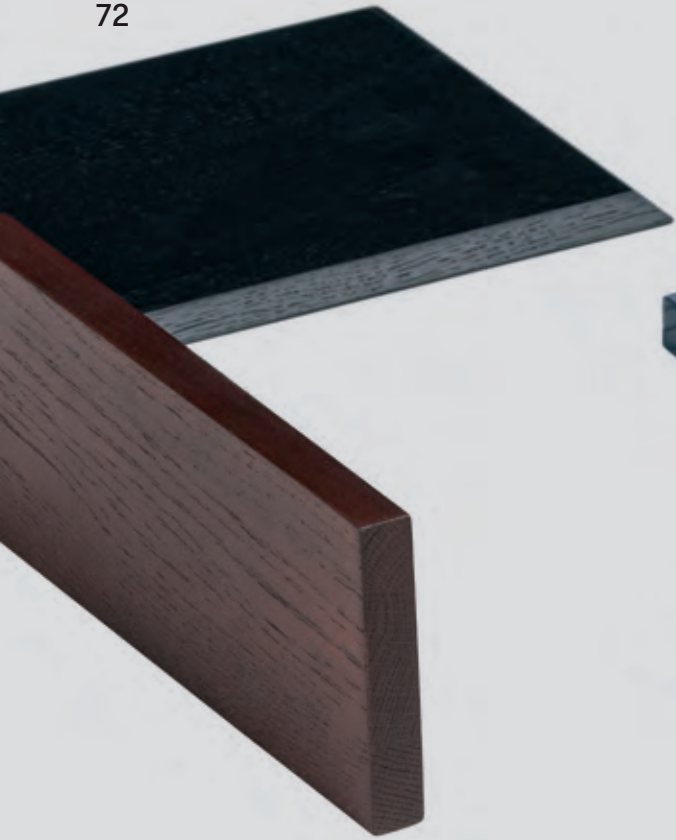

ORIGINAL
board in tray

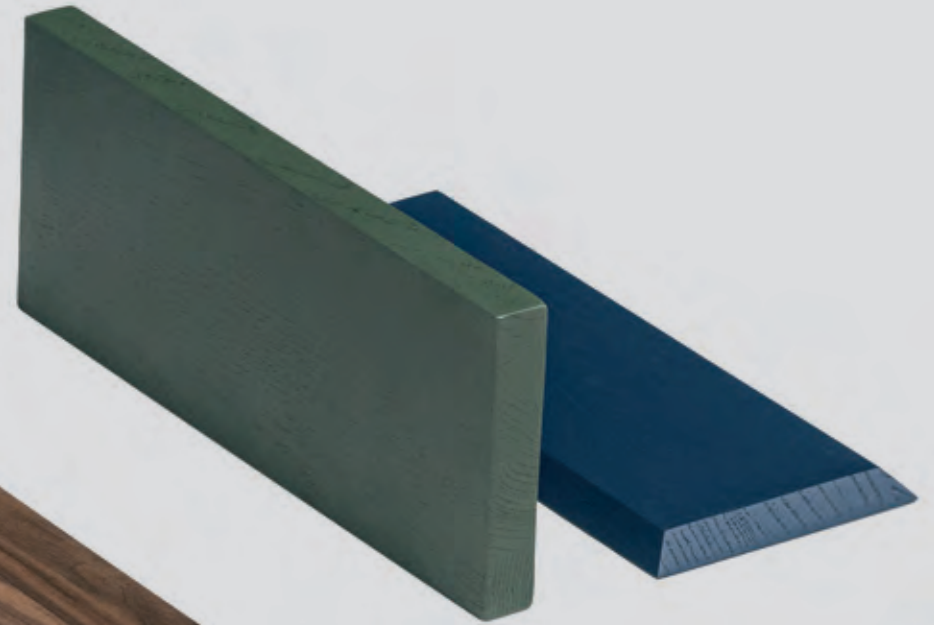

ORIGINAL
board in tray ½

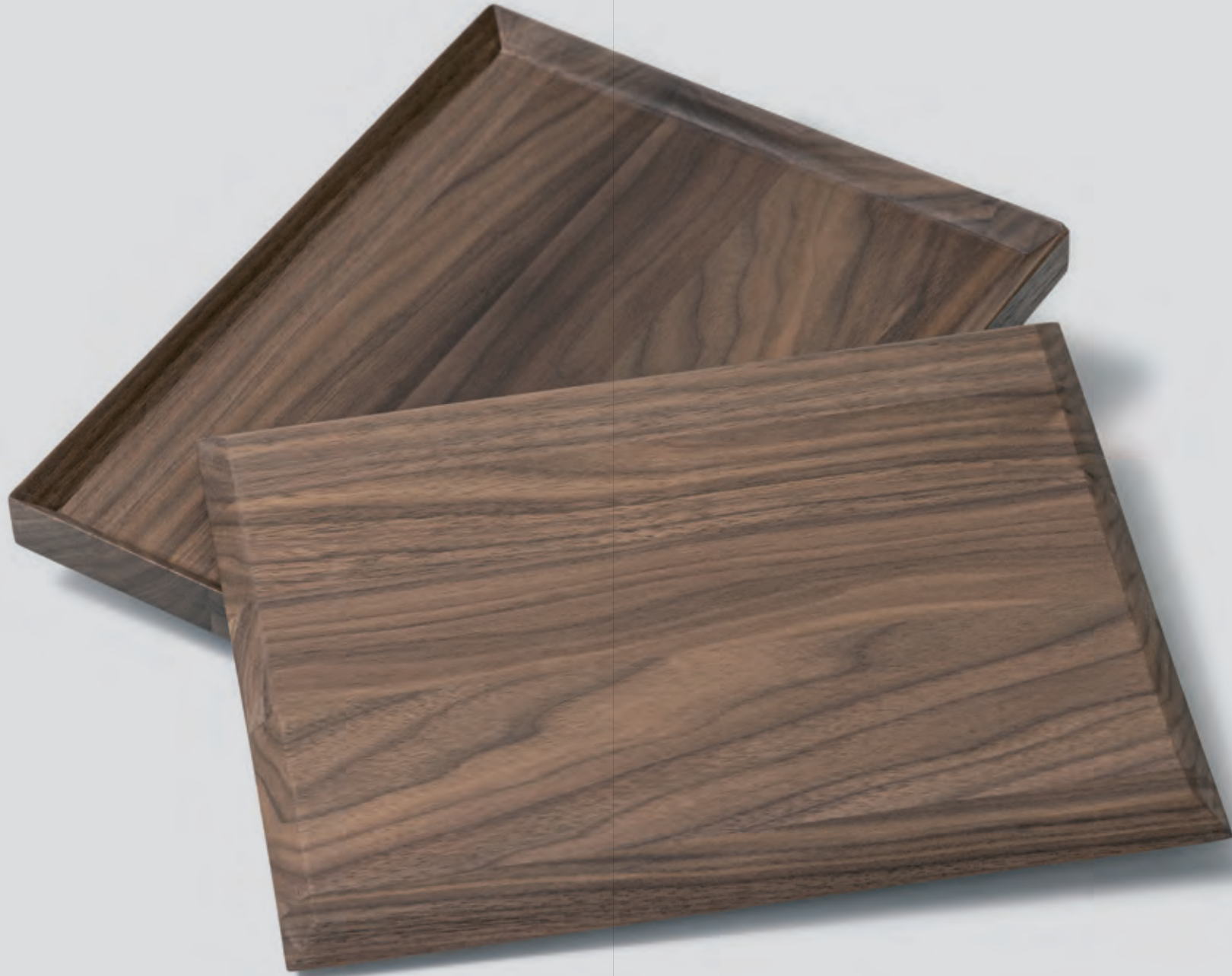

ORIGINAL
board in tray



ORIGINAL
dome
coffret



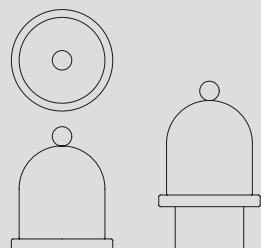

ORIGINAL dome coffret

Design: Peter Gregson
Material: Walnut or oak
Surface treatment: Oil

Dimensions

W		D		H
13 cm	x	13 cm	x	15 cm

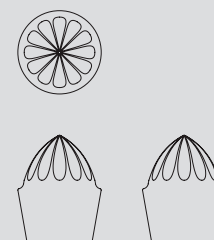

ORIGINAL cup squizer

Design: Peter Gregson
Material: Walnut or oak
Surface treatment: Oil

Dimensions

W		D		H
7 cm	x	7 cm	x	9 cm

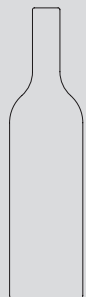
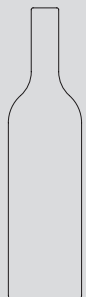
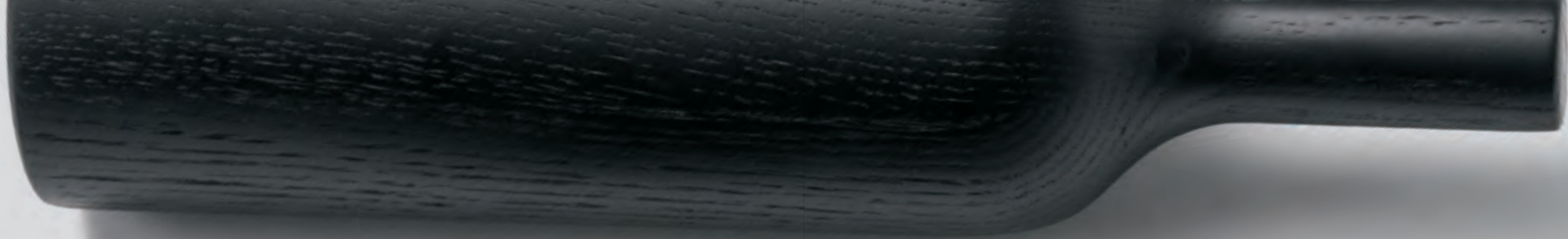

ORIGINAL rolling pin bottle

Design: Peter Gregson
Material: Walnut or oak
Surface treatment: Oil

Dimensions

W		D		H
8 cm	x	8 cm	x	32 cm

Designed by Raquel Pacchini.
Interlocking wooden elements
rhythmically overlap in a game
of unexpected geometries.
The natural raw material
is the protagonist of the
compositions, sometimes
tinged with color becomes a
painting. This metaphorical
dialogue between solids
and voids manifests the
encounter of graphic and
architectural approaches.

UNEVEN

23



NERVOSA
chair with
armrest

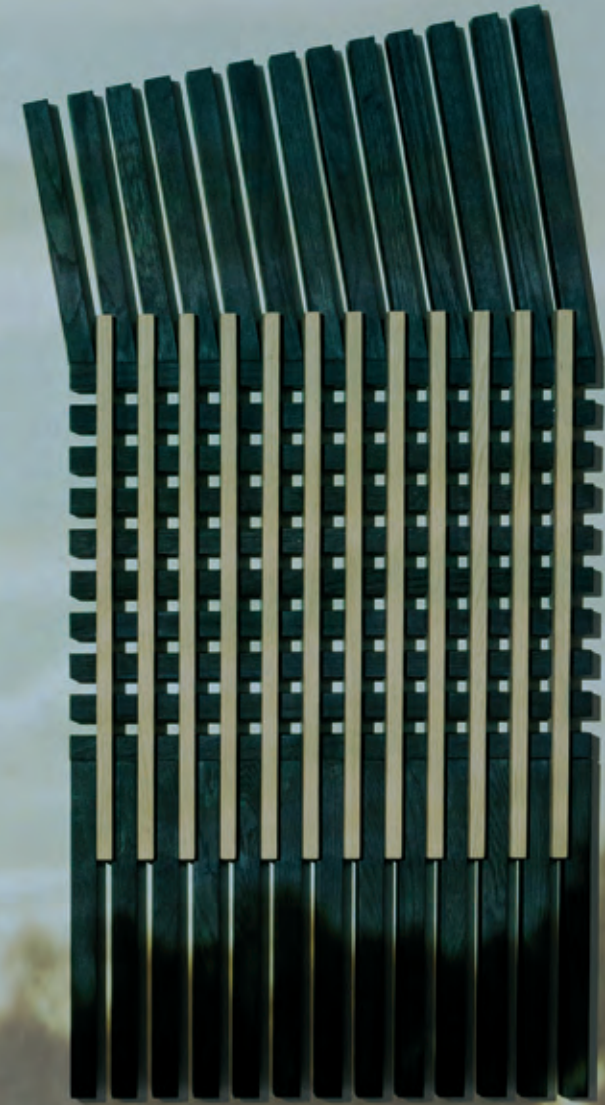

UNEVEN
wall wood rug

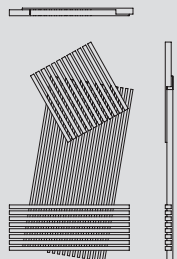
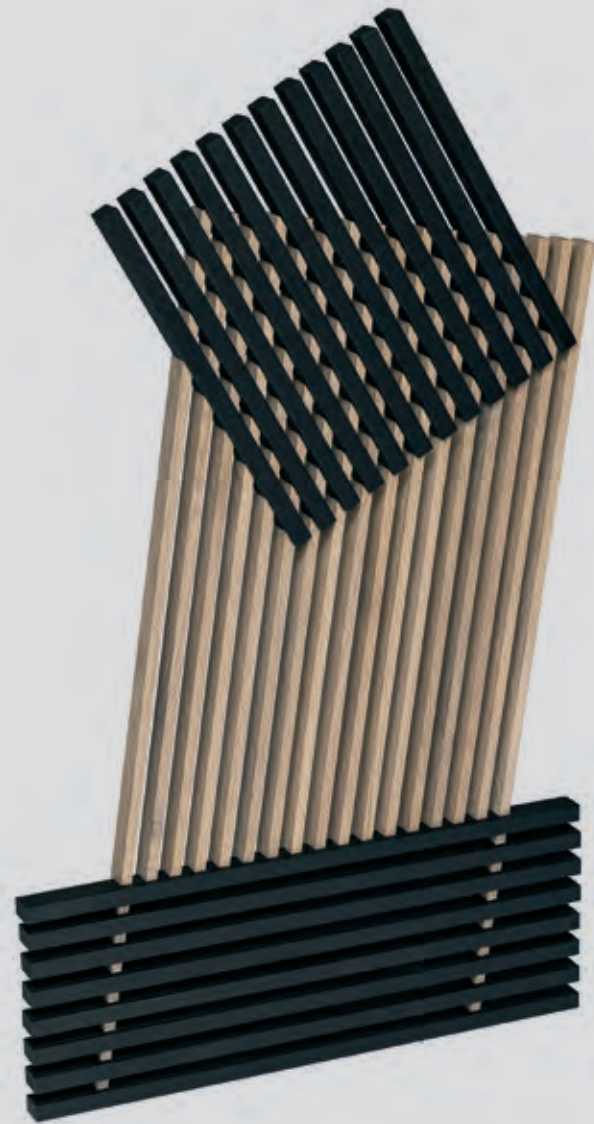

UNEVEN wall wood rug

Design: Raquel Pacchini
Material: Walnut or oak
Surface treatment: Oil

Dimensions

W		D		H
140 cm	x	83 cm	x	5 cm

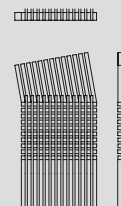
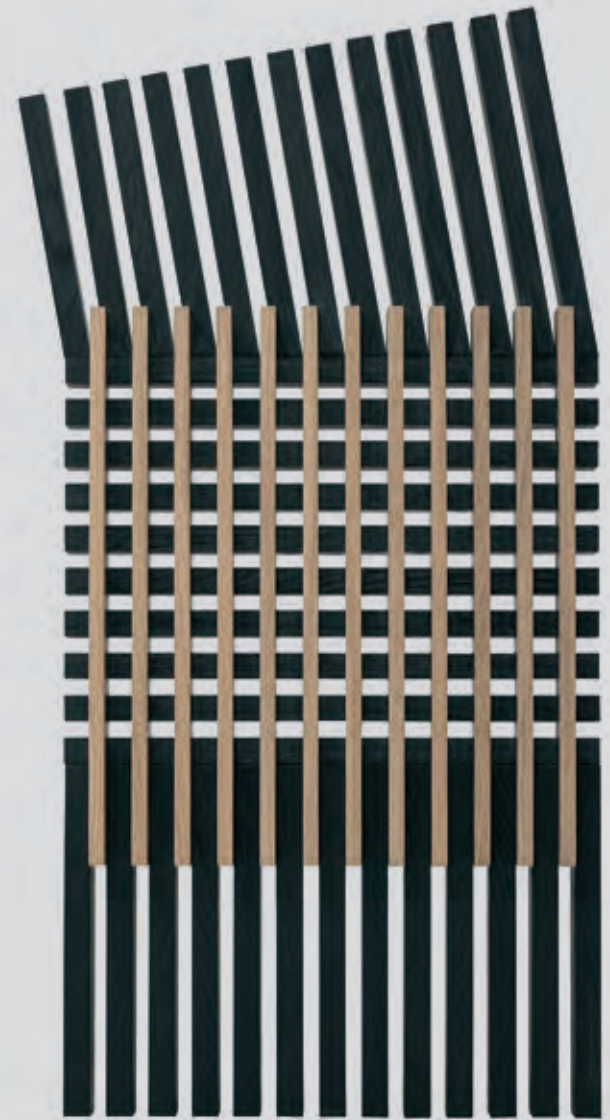

UNEVEN wall wood rug

Design: Raquel Pacchini
Material: Walnut or oak
Surface treatment: Oil

Dimensions

W		D		H
105 cm	x	55 cm	x	8 cm

Designed by Matteo Cibic.
Vesna is a mythological female character from Slavic cultures who represents spring. The beautiful Vesnas used to descend from their mountaintop palaces astride wooden cycles singing and discussing the fate of people and crops. They used to park their cycles on special wooden trestles that still bear their name today.

VESNA

23

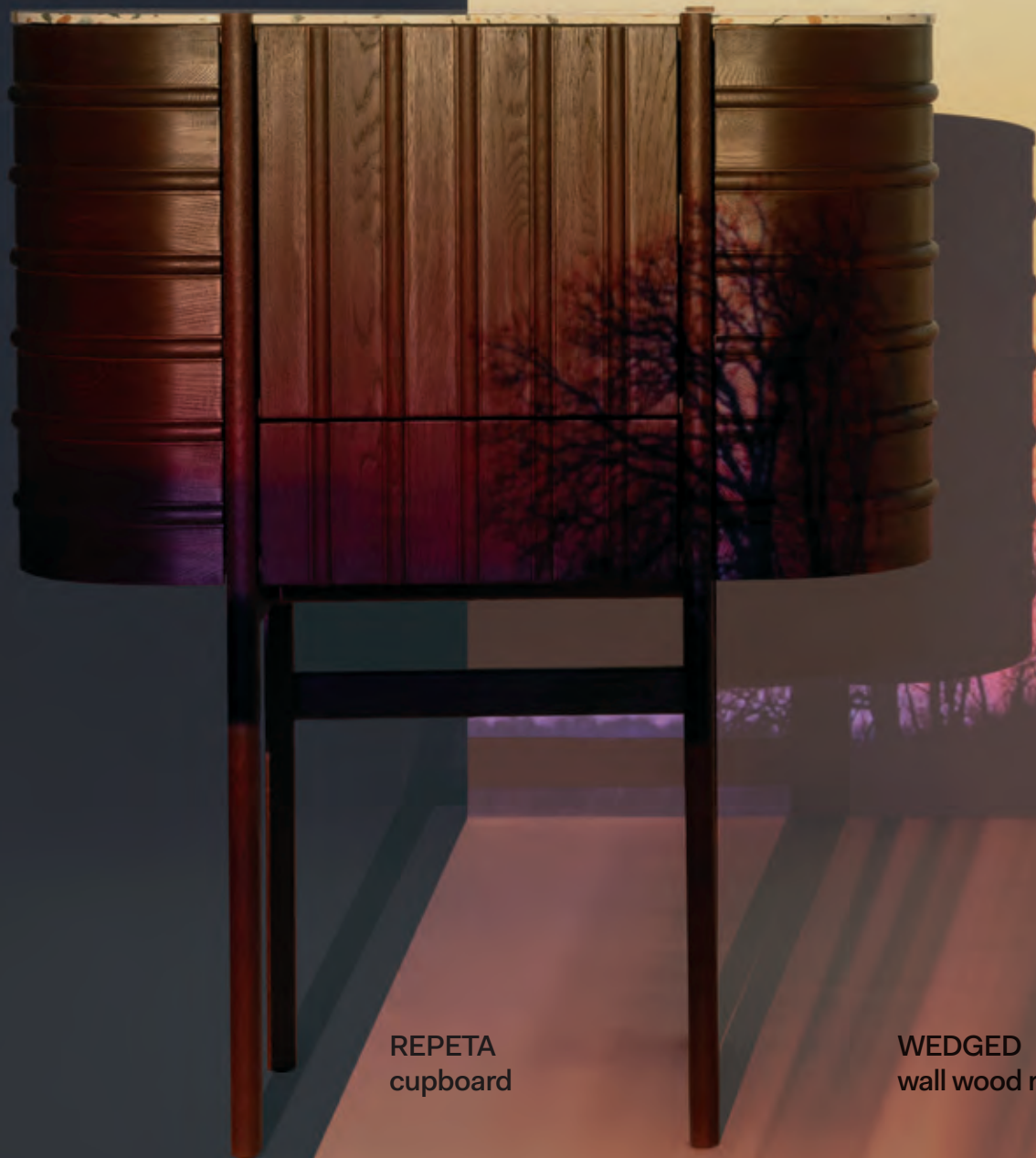

REPETA
cupboard



WEDGED
wall wood rug



VESNA
bike stand

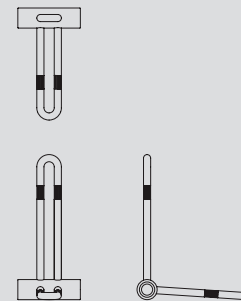

**VESNA
bike stand**

Design: Matteo Cibic
 Material: Walnut or oak
 Surface treatment: Oil

Dimensions

W		D		H
50 cm	x	28 cm	x	65 cm

Designed by Raquel Pacchini.
Interlocking wooden elements
rhythmically overlap in a game
of unexpected geometries.
The natural raw material
is the protagonist of the
compositions, sometimes
tinged with color becomes a
painting. This metaphorical
dialogue between solids
and voids manifests the
encounter of graphic and
architectural approaches.

WEDGED

23



WEDGED
wall wood rug

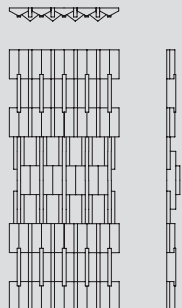
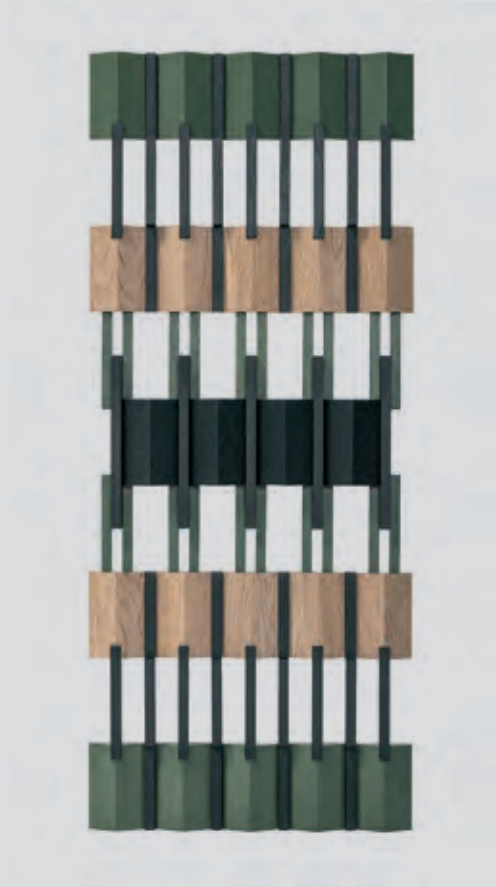

WEDGED
wall wood rug

Design: Raquel Pacchini
 Material: Walnut or oak
 Surface treatment: Oil

Dimensions

W		D		H
150 cm	x	63 cm	x	8 cm

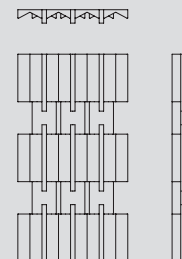
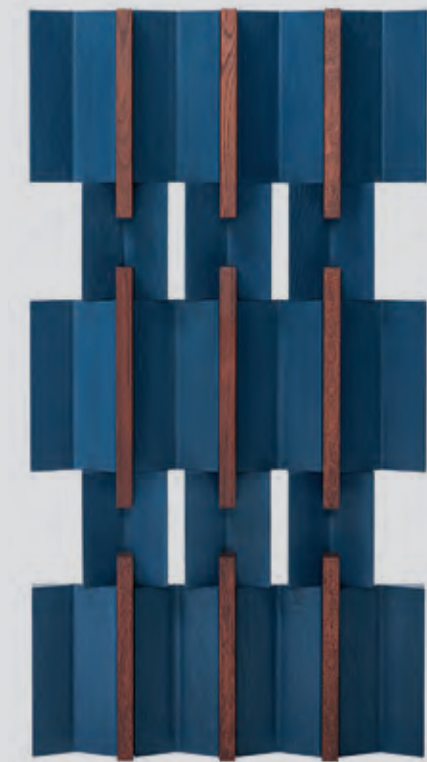

WEDGED
wall wood rug

Design: Raquel Pacchini
 Material: Walnut or oak
 Surface treatment: Oil

Dimensions

W		D		H
93 cm	x	49 cm	x	6 cm

A meltin pot DNA where skills originate from crossed cultures and combine with the woodworking tradition of the land where the raw material comes from. Woak symbolises the strength of a company and the desire to open up to the new with an almost nomad vocation to travel and absorb knowledge from all over the world and then mix it with the original heritage of craftsmanship carpentry.

Instead of products, we create “pieces”, crafted with great care for the users as well the environment. We are passionate about working with the warmth of solid wood, especially oak and walnut, and attach great importance to sustainable raw materials.

MATERIALS

23

wood



1 Oak White 2 Oak Sand 3 Oak Green 4 Oak Blue 5 Oak Black 6 Oak Red

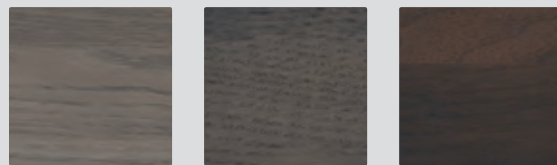

7 Oak Taupe 8 Oak Planked gray 9 Walnut Natural oil

mirror

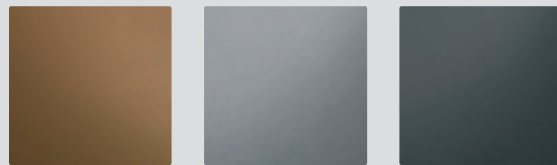

Bronze Clear Smoke

marble

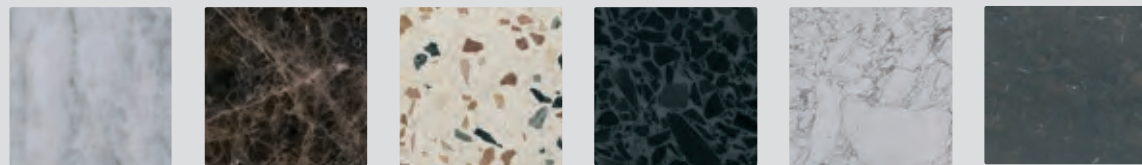

Carrara Emperador Murano Burano Arabescato Breccia Imperiale



Fabric Remix / 123 Fabric Remix / 163 Fabric Remix / 223 Fabric Remix / 242 Fabric Remix / 433 Fabric Remix / 773



Fabric Remix / 823 Fabric Remix / 852 Fabric Remix / 933 Fabric Remix / 982 Fabric Ponza 7027.13 Fabric Ponza 7027.25

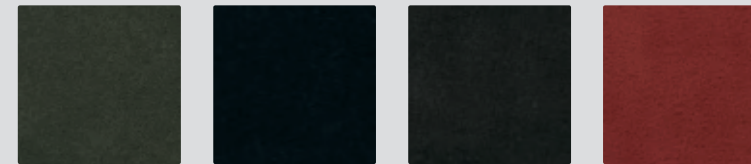

Fabric Ponza 7027.31 Fabric Ponza 7027.29 Fabric Ponza 7027.14 Fabric Ponza 7027.02

leather



Leather Vision / Polvere Leather Vision / Cognac Leather Vision / Terracotta Leather Vision / Granada Leather Vision / Amarena Leather Vision / Constagna

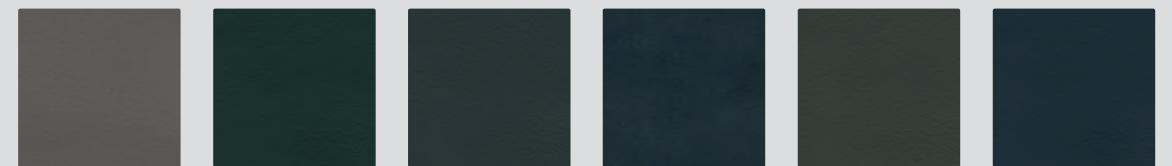

Leather Vision / Visione Leather Vision / Foresta Leather Vision / Piombo Leather Vision / Nero Leather Thema 6291 Leather Thema 6293

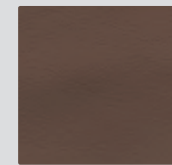

Leather Vision / Cammello

Woak

23