



Step

BY VINCENT VAN DUYSSEN

Step

BY VINCENT VAN DUYSSEN

Technical Info EN

2013



A strong relationship exists between Van Duysen's designs and his architectural projects – he chooses to develop furniture and objects from an architectural perspective – creating spatial relations rather than shapes. A rescaled interpretation of his architectural work, Van Duysen creates pieces that provide a sense of purity and essentialism, yet remaining tactile and grounded.



Vincent Van Duysen

Vincent Van Duysen was born in Lokeren, Belgium, in 1962, and undertook a degree in Architecture at the Higher Institute of Architecture Sint-Lucas, Ghent. Between 1986 and 1987 Van Duysen worked in Milan collaborating with Aldo Cibic – Sottsass Associati, after which, in 1990, he opened his studio in Antwerp specializing in architecture and interiors.

A strong relationship exists between Van Duysen's designs and his architectural projects – he chooses to develop furniture and objects from an architectural perspective – creating spatial relations rather than shapes. A rescaled interpretation of his architectural work, Van Duysen creates pieces that provide a sense of purity and essentialism, yet remaining tactile and grounded.

Subsequently, many of the designs refer to essential forms, tradition or well known masterpieces which Van Duysen redefines through a contemporary lens. A balance of form and proportion – without omitting durability, function, and comfort – is critical to the design process. The use of pure and tactile materials results in a clear and timeless design. An architectural language which is not shy of aesthetics, but resists fashion and trends. Van Duysen embraces these emotional aspects to celebrate 'the art of living'.

Van Duysen's work has been published widely – in 2001; an inaugural monograph was published by the Spanish GG Editions. The first monograph 'Complete Works', published by Thames & Hudson in 2010, focused on his multidisciplinary approach where architecture, interior architecture, and design are equally considered. In 2013 the office was approached by Portuguese publisher A.MAG to release an edition of selected works and again 2016 by Japanese magazine A+U. A fifth monograph – again by Thames & Hudson – will document the most recent work captured by a selection of world-renowned architecture and interior photographers, due for release in 2018.

ST70
module 70 | 27 5/16"

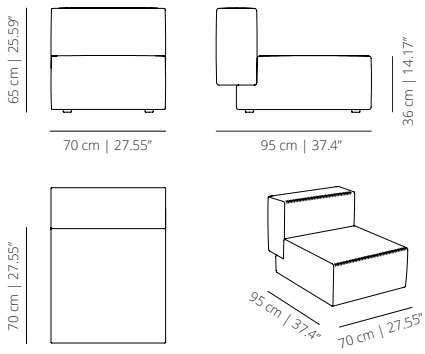

ST90
module 90 | 35 7/16"

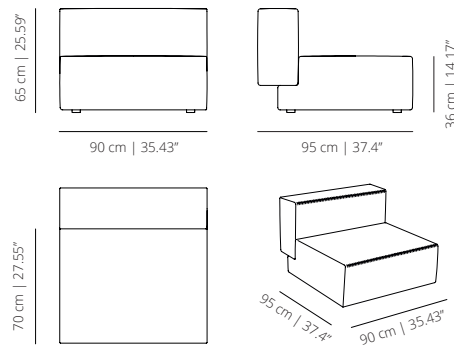

STCH
chaise

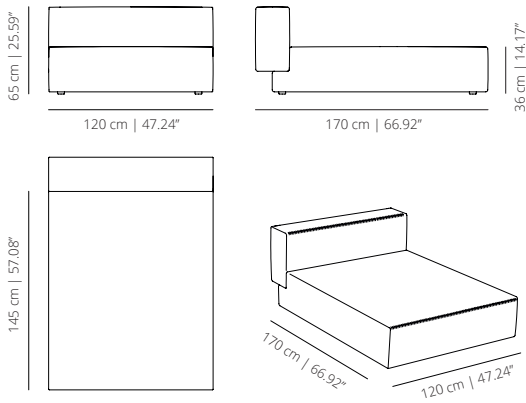

STRI
corner

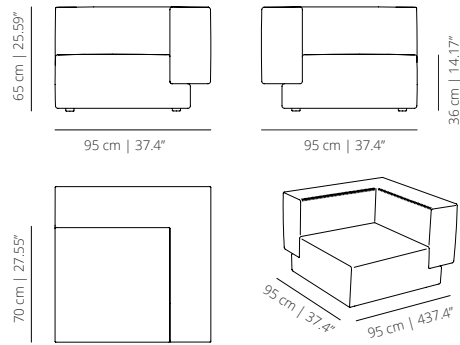

STPO
pouf

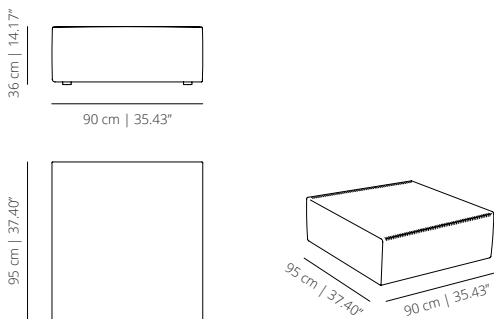

STWA
narrow arm

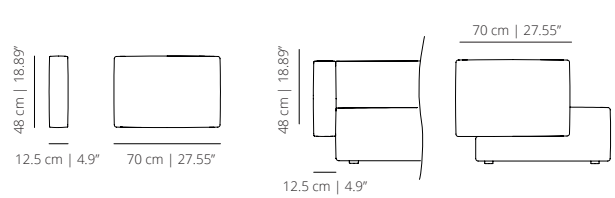

STTA
wide arm

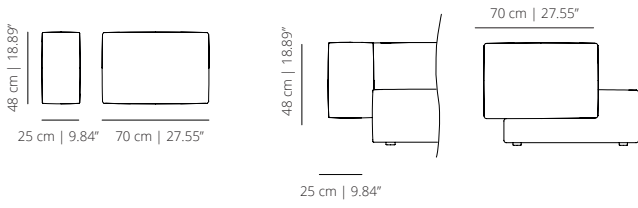

SUGGESTIONS

COMPOSITION 1

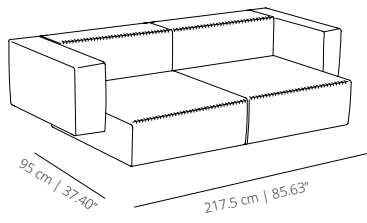

COMPOSITION 2

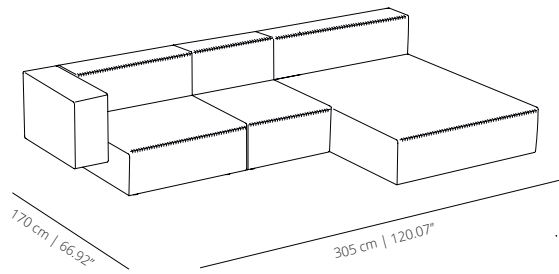

COMPOSITION 3

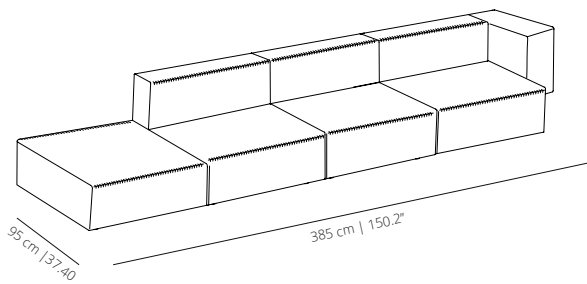

COMPOSITION 4

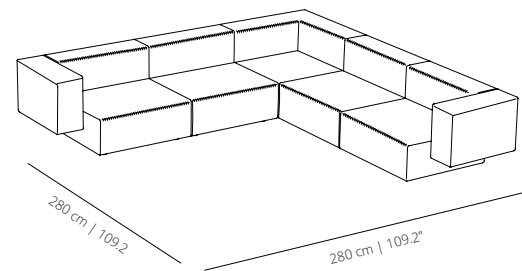

SUGGESTIONS

COMPOSITION 5

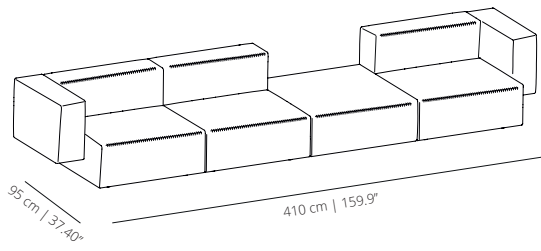

COMPOSITION 6

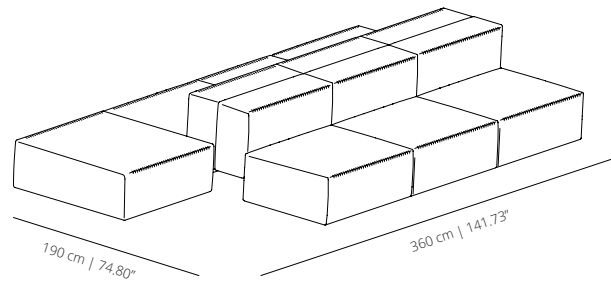

CUSHIONS

STAL25

cushion 50x25 | 9.84"x19.69"

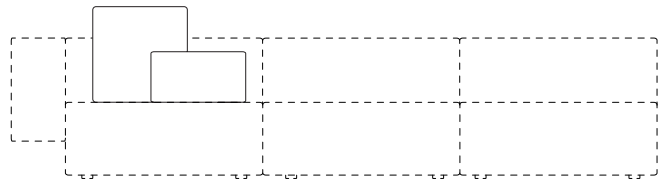
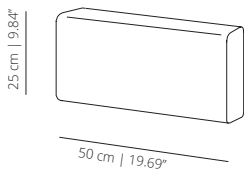

STAL50

cushion 50x50 | 19.69"x19.69"

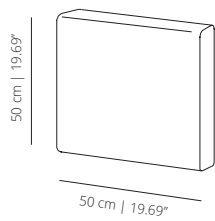

FINISHES

Upholstery

Check upholstery samples.

SEAM*



white



black



red



sky blue



dark grey



green



cream



deep blue



caramel



wine



light grey



**Decorative seams are made by hand.*

TECHNICAL INFO

Interior structure of arms, back and seat in solid wood. We use PEFC certified wood. Woven seat and back structure. Expanded polyurethane foam in different densities. Polyester fibre covering. Fabric. Height equalising legs.

Not produced in leather.

Seam – colours available: white, black, red, sky blue, light grey, dark grey, green, cream, deep blue, caramel and wine.

Cushions – soft virgin fibre with anti-acarus treatment.

CERTIFICATIONS

ANSI/BIFMA X5.4-2012 and UNE EN 16139:2013



viccarbe