

viccarbe

Master Catalogue

Mediterranean Collaboration

PART 1



MEDITERRANEAN COLLABORATION

It seems clear that the borders between spaces are almost non-existent, offices look like hotels, hotels look like houses, houses... The habitat has become an umbrella that gathers more and more similar spaces looking for comfort, singularity and recognition, but what makes a project really unique?

At a time such as the present, surrounded by ephemeral fashions, I would like to explain how we, in Viccarbe, understand the concept of Mediterranean collaboration. Viccarbe is a company born in Valencia, a Mediterranean city where we have lived for centuries with cultures as diverse as the Roman, Visigoth and Muslim. This cultural mix makes our genes a cocktail so diverse that we are designed in a natural way for collaboration and adaptation away from limitations and flags.

All of this is part of our soul, added to more than 300 days of sunshine a year and a diet that positions us as one of the most long-lived countries in the world. I believe that somehow, being so

optimistic and timeless is reflected in the way we design and showcase our collection. We are driven by a passion for listening, seeking what unites us rather than what sets us apart, always with the person as the focus and fundamental axis of each new project.

In an increasingly digital world, we consider that humanism will be more core than ever and, in this matter, we have many years—I dare say even centuries—of advantage.

Nature loves simplicity and unity, this is why we put so much effort into it, and that is why it is so important for us to create friendly and iconic products, that naturally provoke new and unexpected relationships between users, because good design shouldn't have to be explained.

The natural cross between people and attraction between users, spontaneously promoted by our products, generates collaborative connections that provoke innovative ideas and unexpected solutions.

VICTOR CARRASCO BERLANGA

Founder, VICCARBE

Index

MEDITERRANEAN COLLABORATION
1

DESIGNED IN THE SUN
4

VICCARBE.COM
6

DESIGNERS
8

THE COLLECTION
10

SAVINA SOFA
12

CAMBIO TABLE
52

CAMBIO LOW TABLE
76

ALETA CHAIR
88

ALETA STOOL
112

ALETA LOUNGE CHAIR
122

BURIN TABLE
130

SOLAR TABLE
144

COMMON BENCH
164

COMMON LOW TABLE
162

TRESTLE TABLE
174

TRESTLE BENCH
198

SISTEMA COLLECTION
208

EARS CHAIR
252

EARS STOOL
258

VICCARBE KITCHEN
262

COPA CHAIR
264

COPA STOOL
272

COPA LOUNGE CHAIR
276

MAARTEN PLASTIC CHAIR
284

MAARTEN PLASTIC STOOL
312

MAARTEN CHAIR
316

MAARTEN STOOL
330

MAARTEN LOUNGE CHAIR
332

FUNDA CHAIR
338

FUNDA LOUNGE CHAIR
346

FUNDA STOOL
348

KLIP CHAIR
356

KLIP STOOL
372

QUADRA CHAIR
376

ACE LOUNGE CHAIR
396

PENTA ARMCHAIR
406

LEVITT COLLECTION
416

SEASON CHAIR
430

SEASON SOFA
440

SEASON BENCH
452

SEASON POUF
460

STEP SOFA
468

NAGI ARMCHAIR
484

LAST MINUTE STOOL
494

STANDARD TABLES
500

BRIX ARMCHAIR
506

TORII BENCH
512

COLUBI ARMCHAIR
520

FEDELE ARMCHAIR
532

WRAPP ARMCHAIR
538

LOW TABLES
542

ACCESSORIES
576

QUICK EXPEDITION
582

COMING SOON
584

LATEST PROJECTS
592

OUR CLIENTS
597

MORE INFO
598

FABRICS & SAMPLES
604

VICCARBE 3D AWARDS
606

Designed in the Sun

"Our soul belongs to the Mediterranean."

Our soul belongs to the Mediterranean. Here, light has an impressive influence on who we are, how we live and how we feel. Our warm character, our relaxed vibe, and the way we take care of what really matters reflects our deep connection with the sun. We are creativity, energy, and spontaneity.

In the Mediterranean, design lives free of all pretense, combining warmth, simplicity, and convenience. Everything has a purpose, there is no room for unnecessary excess and only the truly important remains.

Natural light exerts a powerful influence in our sketches. This glow is what brings everything to life and unleashes our artistic soul. It is part of our identity and it is the starting point of our designs, reflected through our passion for colors, the warmth we convey, our attention to detail and in the way we appreciate the small things.

We enjoy being surrounded by people, we like to share, communicate, and learn from the talented ones we admire. Collaborative work has always been part of our culture. Meaningful collaboration can improve communication and make everyone feel part of a whole. We are firm defenders of collaborative spaces where imagination releases to create perfect synergies.

Our collection is an essential selection of Mediterranean pieces for spaces where collaboration and dialog flow. This is the consequence of our "Designed in the Sun".



On the right, a picture of Viccarbe Fábrica

viccarbe.com

2D · 3D · BIM · Revit · Techinal Sheets · Quality
Tests · Samples · pCon

We want to welcome you to the place where everything happens, where we invite you to enjoy reading and to take in huge doses of inspiration. Make www.viccarbe.com your comfort zone, like a workplace with greater flexibility and freedom of movement. Make yourself comfortable and keep your curiosity. Enjoy the journey.

Design is our journey

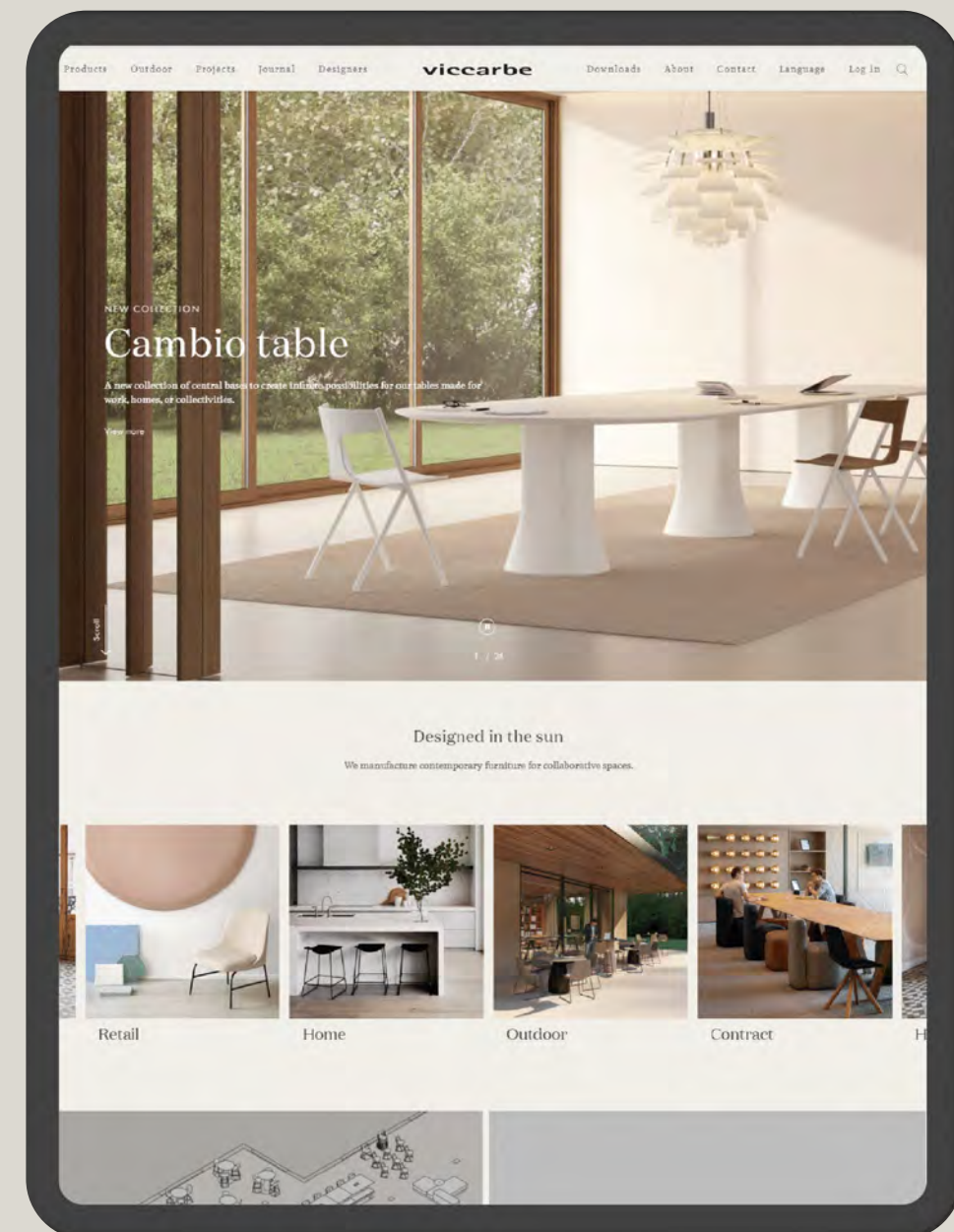

Our designers

Talent across the globe



ELISA OSSINO



JAIME HAYON



JEAN-MARIE MASSAUD



PATRICIA URQUIOLA



PEDRO PAULO-VENZON



PIERO LISSONI



JOHN PAWSON



RAMOS&BASSOLS



JORGE PENSI



RAMÓN ÚBEDA Y OTTO CANALDA



STEFAN DIEZ



TOAN NGUYEN



KENSAKU OSHIRO



LIEVORE ALTHERR MOLINA



L + R PALOMBA



TOMOYA TABUCHI



VÍCTOR CARRASCO



VINCENT VAN DUYSEN



MARIO FERRARINI



MARC KRUSIN



NAOTO FUKASAWA



JASPER MORRISON

We cannot predict the future but we can design our own with the help of the most talented ones. We strive to improve everyday by learning from the best, we are always evolving and constantly seeking ways of getting better. We are honoured that the world's top designers wish to interpret our Mediterranean lifestyle, regardless of their country of origin, to conceive sensational pieces to brighten our lives.

The Collection



Ears Chair - Pg. 252



Quadra Chair - Pg. 376



Copa Chair - Pg. 264



Funda Chair - Pg. 338



Maarten Plastic Chair - Pg. 284



Maarten Chair - Pg. 316



Aleta Chair - Pg. 88



Klip Chair - Pg. 150



Season Chair - Pg. 430



Maarten Plastic Stool - Pg. 312



Maarten Stool - Pg. 332



Maarten Plastic Stool - Pg. 312



Maarten Stool - Pg. 330



Aleta Stool - Pg. 112



Klip Stool - Pg. 372



Copa Stool - Pg. 272



Copa Stool - Pg. 272



Copa Stool - Pg. 272



Ears Stool - Pg. 258



Funda Stool - Pg. 348



Last Minute Stool - Pg. 494



Copa Lounge Chair - Pg. 276



Aleta Lounge Chair - Pg. 122



Maarten Lounge Chair - Pg. 332



Ace Armchair - Pg. 396



Colubi Armchair - Pg. 520



Funda Lounge Chair - Pg. 340



Sistema Armchair - Pg. 246



Sistema Armchair - Pg. 246



Sistema Armchair - Pg. 266



Sistema Armchair - Pg. 246



Brix Armchair - Pg. 506



Nagi Armchair - Pg. 484



Penta Armchair - Pg. 406



Wrapp Armchair - Pg. 538



Savina Armchair - Pg. 146



Sistema Armchair - Pg. 244



Sistema Armchair - Pg. 244



Step Armchair - Pg. 483



Fedele Armchair - Pg. 532



Levitt Armchair - Pg. 416



New addition, Funda Collection - Pg. 590



Sistema Legs Sofa - Pg. 208



Sistema Floor Sofa - Pg. 238



Levitt Sofa - Pg. 416



Step Sofa - Pg. 468



Season Sofa - Pg. 440



Savina Sofa - Pg. 12



Trestle Bench - Pg. 198



Common Bench - Pg. 162



Sistema Bench - Pg. 246



Season Bench - Pg. 452



Toril Bench - Pg. 512



Season Pouf - Pg. 458



Trestle Table - Pg. 174



Solar Table - Pg. 144



Eli Table - Pg. 500



Stan Table - Pg. 500



Maarten Table - Pg. 324



Burin Table - Pg. 130



Cambio Table - Pg. 52



New table (Jasper Morrison) - Pg. 586



New table (John Pawson) - Pg. 588



Cambio Low Table - Pg. 76



Eli Low Table - Pg. 574



Aleta Low Table - Pg. 556



Ryutaro Low Table - Pg. 550



Shape Low Table - Pg. 554



Tiers Low Table - Pg. 560



Window - Pg. 578



Stan Low Table - Pg. 570

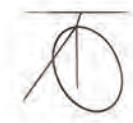

Bamba Low Table - Pg. 662



Giro Low Table - Pg. 558



Keel Shelves - Pg. 580



Up in the Air, Low Table - Pg. 568



Burin Mini Low Table - Pg. 546



Trino Low Table - Pg. 548

SAVINA

Island of collaboration

A sofa designed by Victor Carrasco, 2022

2022 — Savina joins our collection of ancillary furniture to enhance soft collaboration. An innovative sofa that presents a new universe of comfortable working solutions for every office, workplace, home, hospitality area or hybrid space.

Due to its soothing silhouette and its infinite compositions, we like to call it an island of collaboration, a reassuring spot to gather, work and retreat. An original, flexible and mindful sitting concept for hybrid spaces to nurture synergy, creativity, productivity, and well-being.

Get immersed and transport yourself into the era of soft collaborative comfort with Savina. This is Savina.



Savina takes its name from the natural entrance to the island of Formentera

Savina takes its name from the natural entrance to the island of Formentera in Spain. This island is possibly one of the most serene places in the Mediterranean that connects you with nature and makes you unwind. This pleasant feeling of relaxation is what we wanted to recreate when sitting on a Savina sofa.



Featuring Savina with chaise longue, matching cushions and upholstered arm





Featuring Savina sofa with different modules, auxiliary tables and matching cushions



Infinite modularity with ease of movement, agility and comfort



With hidden casters.
Pure dynamism.



Savina



ECOALF
EDITION



Ecoalf is a pioneer international sustainable fashion brand and is now our exclusive partner. Together, we lead the way to a more sustainable interior design industry

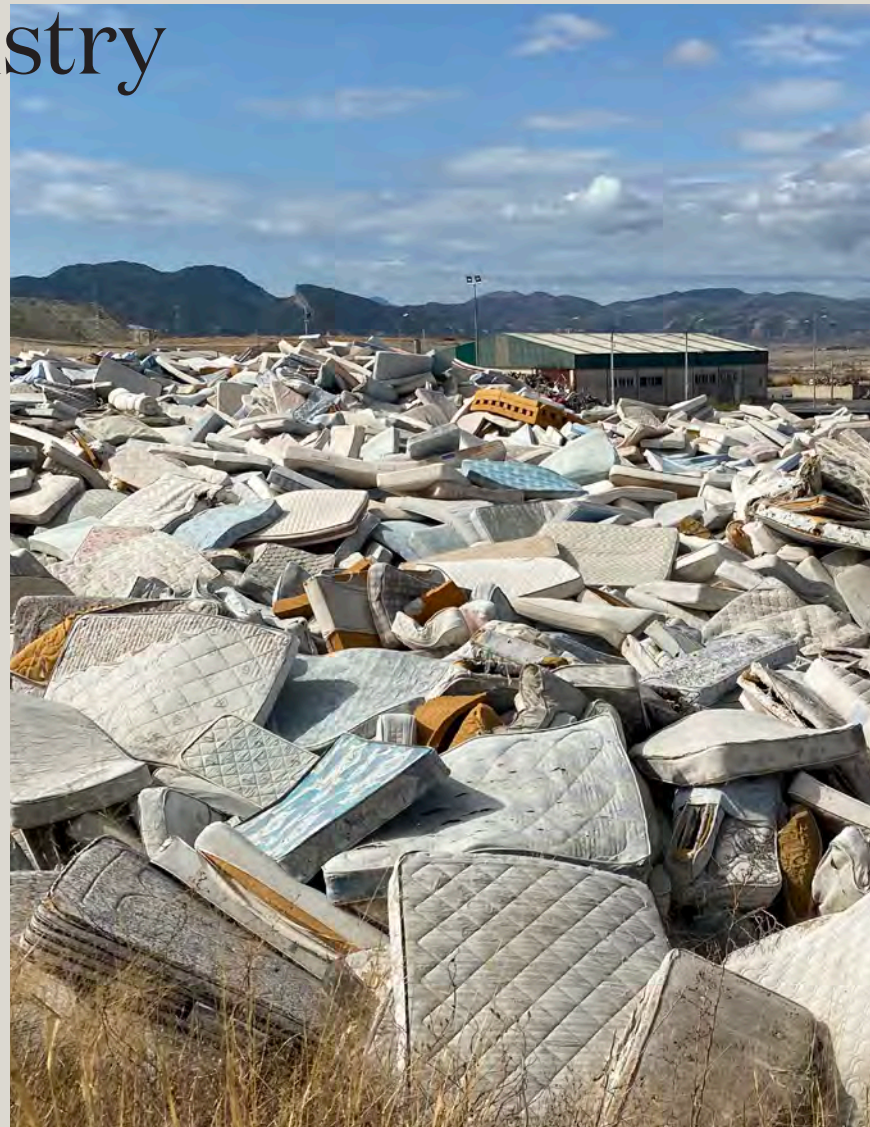

On the left, Victor Carrasco founder of Viccarbe. On the right, Javier Goyeneche founder of Ecoalf. Both sitting on Maarten chairs upholstered in recycled fabrics by Ecoalf

As a novelty, Savina is also available with fabrics from recycled materials by Ecoalf, the pioneer brand in sustainable fashion. This joint venture materialized with a first edition of our iconic Maarten chairs, upholstered with their recycled fabrics made with residues collected from oceans around the world. As drivers of innovation within the fashion and design sectors, together with Ecoalf we blend our know-how in order to lead the journey to sustainability within the furniture and design industry. The aim of our collaboration is to highlight the responsibility of every manufacturer and agent involved in the furniture industry, and to achieve a positive outcome for the environment.

With Savina, Ecoalf edition, we have now gone a step further. We wanted to design a sofa to last many years, upholstered with Ecoalf's ethically recycled materials, and ingeniously made with wood from controlled timber, recycled and recyclable steel springs, and a percentage of soft padding from recycled mattresses collected by Recipur. Together, we lead the change to raise awareness in the design industry. *Because there is no Planet B.*

"A pioneer joint venture in the pursuit of maximum sustainability in the design industry."



In the EU, over 10.7 million tonnes of furniture waste are generated annually with 80-90% being incinerated or sent to landfill



**1. PROBLEM:
DISCARDED FURNITURE**

In Spain alone, over 1.5 million mattresses end up in landfills each year.



**2. SOLUTION:
RECIPUR COLLECTS THEM**

They use an innovative process to recycle the mattresses and give them a second life.



**3. ECOPURE® TECH:
70% RECYCLED FOAM**

With years of scientific studies, the foam provides the sofa maximum comfort.



**4. OUR COLLABORATION:
THE SAVINA SOFA**

The three companies come together to offer a cutting-edge sofa that promotes the circular economy.

R&D IN RECYCLED MATERIALS

ECOPURE®'s recycled foam technology recycles post-consumer mattresses and perfectly cushions the piece, it is upholstered with Ecoalf's recycled fabric to save water, reduce CO2 emissions and avoid using new resources.

ECO-DESIGN & CIRCULARITY

Designed with the end in mind, using the least number of parts and a minimal form so that the 7 pieces of the modular sofa can easily be deconstructed and the parts recycled into new pieces.

ECO-DESIGN & CIRCULARITY

Designed with the end in mind, using the least number of parts and a minimal form so that the 7 pieces of the modular sofa can easily be deconstructed and the parts recycled into new pieces.

TRACEABILITY & PROXIMITY

100% Made in Spain, every single step from the design to the production takes place within a 100km mile range of Viccarbe's HQ.

A TIMELESS SOFA WITH ECOALF FASHION RECYCLED FABRICS

Five timeless colors, aligned with Ecoalf's coveted fashion collection, are available for Savina's upholstery. Soft and pleasant recycled fabrics by Ecoalf, made from over 250 million plastic bottles collected in oceans. These residues are first transformed into flakes and pellets in order to obtain a high-quality, 100% recycled filament to create long-lasting top-quality garments and upholstery fabrics for our Maarten and Savina lines. Choose your favorite color combination to create a sofa designed to last.

Visit Ecoalf.com for more info

COLORS



White sand



Dusty Olive



Topo



Caviar



Petrol



Savina Chaise

"The independent chaise invites you to work for hours, exchanging ideas, working solo or in teams."



A versatile chaise with casters to focus whilst performing the daily tasks. Designed to last



Featuring Savina Chaise with wooden table and technical fabric for extra resistance, designed to last



CONNECTIVITY & MOBILITY

Connectivity is sorted thanks to its useful electrification options and its hidden casters add freedom of movement.

SAVINA & WORK

Working on a chaise longue has multiple benefits for the mind and soul. A practical and comfortable addition to places that seek a special seat for visitors, and workers to perform, relax and unwind. A piece that makes a great use of the space available and conveys a welcoming spot when looking for inspiration.

MULTIPLE OPTIONS TO CHOOSE FROM

Savina Chaise has multiple options: includes hidden casters, making it easy to place it anywhere and to create infinite combinations depending on the situation, accessories such as wooden tables, great when working on the laptop, arranging a videocall or enjoying a quick coffee, and discreet integrated electrifications, solving problems of connectivity when working away from the usual desk.

TECHNICAL FABRIC AT FOOT HEIGHT TO INCREASE DURABILITY

Mix and match different fabrics to achieve a bespoke chaise longue to work all day long. The technical fabric at foot height **brings extra resistance and durability**, adding a modern and relaxed aesthetic to the design. A good option for high-traffic areas: airports, hotel lobbies or staff breakrooms. Made to last.



Featuring Savina sofa with corner module, matching cushions, auxiliary tables, and integrated electrification

The soft silhouette of Savina
is the perfect balance between
visual and physical comfort



Ultimately designed
to encourage users to
engage with others

SAVINA & EDUCATION

Savina brings ultimate comfort to educational centers, enabling students to feel comfortable during reading, studying or leisure time. A sofa created to foster collaboration, ultimately designed to encourage users to engage with others. Perfect to greet visitors and enhance receptions and lounge areas too.





SAVINA & OFFICE

Cleverly designed, Savina is a multi-purpose modular seating system that works in offices and corporate environments, allowing workers to easily rearrange compositions and move it around thanks to its functional hidden casters. An all-rounder that adapts to any workspace scenery effortlessly.

Configure your own Savina sofa

Discover its components



Creating your own Savina sofa is easy, follow these simple steps to find the best match for your space:

1. Choose your favorite modules
2. Choose the upholstery from our graded-in collections (Fabric, leather, eco-leather, recycled by Ecoalf)
3. If required, choose the finish for the arms
4. Accessories: tables, cushions, electrifications...
5. Add hidden casters for unlimited versatility and freedom.

1 Modules

- A. Backless module
- B. Backrest module
- C. End module
- D. Corner module
- E. Chaise

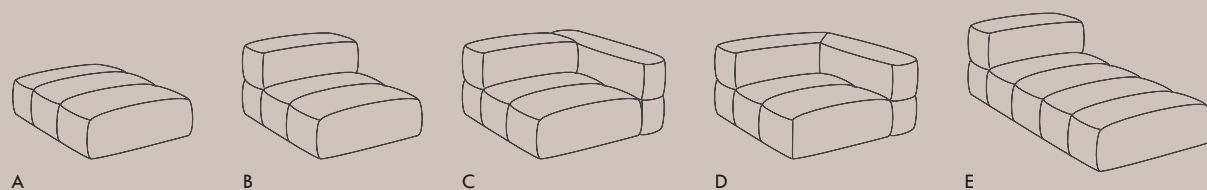

2 Arms

- F. Upholstered arm
- G. End upholstered arm

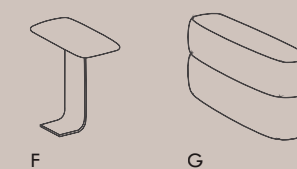

3 Accessories

- H. Table
- I. Cushions

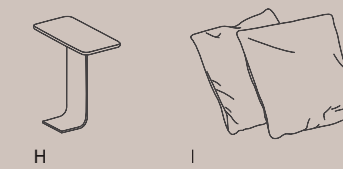

4 Fixed component

- J. Hidden casters

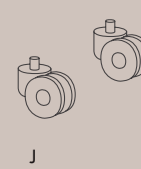



Featuring Savina sofa with different modules, upholstered auxiliary tables, integrated electrifications and matching cushions

SAVINA ARMCHAIR

Savina joins our ancillary furniture collection as a modular collaborative island. The armchair leads to more sustainable working and lounging solutions for homes and offices. A comfortable design which is ideal to create a cozy reading corner in the living room or an inviting welcome area in the office. As a plus, Savina fosters circular economy thanks to its innovative production process, enabling to recycle all its parts independently whenever required.



DESIGNED FOR SUSTAINABILITY

"We have created a recyclable sofa, made with as many components as possible from recycled materials. A living project that will be updated as we continue to strive in recycling innovation."



For us there is nothing more sustainable than creating pieces that will last a lifetime. Pieces that will be part of our journey and will be present in our everyday. Everything we make must be meaningful for the environment and for our lives.

With the clear purpose of leading the way into a more sustainable design industry, with Savina we wanted to go a step further. We pursued a recyclable sofa, made with as many components as possible from recycled materials. A living project that will be updated and renewed as we continue to strive in recycling innovation. We also desired a sofa that was pure comfort, both visually and physically, and invited users to sit on

it for hours, collaborating, sharing thoughts, or just relaxing. Our "design for sustainability" ethos focuses on implementing changes in our collections, that prioritize the environment and foster conscious consumption habits. We have attained a recycled sofa that respects the user's requirements of space, use and function. A flexible sofa that works in any type of environment and contributes to a more respectful design industry. Therefore, we stand to innovate and bring conscious practices into our sector that will lead the change in how we perceive design. We create designs to last.

Illustration showcasing the different components that shape Savina.

Fabrics

Choose your favorite upholstery from our collection, including the recycled fabric line by Ecoalf.

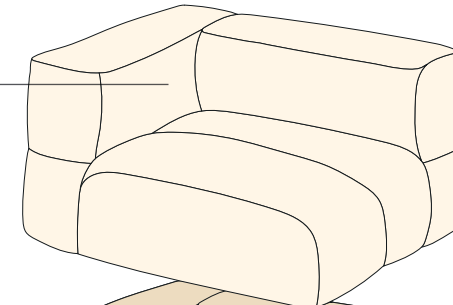

Feathers

RDS certified down fill.

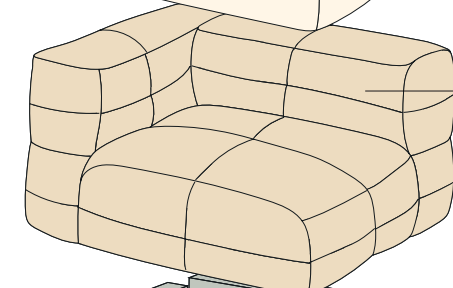

Recyclable foam

Recyclable, non-deformable expanded polyurethane foam of different densities by Recipur.

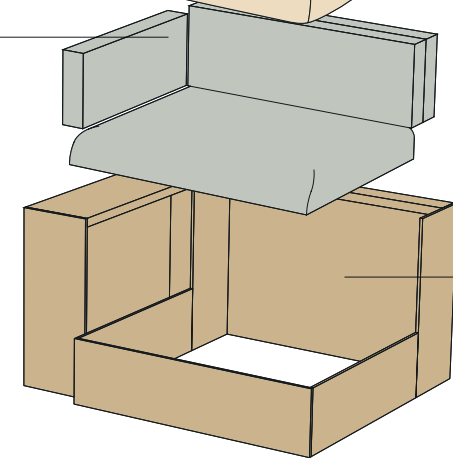

Recycled foam

Medium density recycled polyurethane foam.

Springs

Frame and springs made of high-strength and flexible steel made with recycled materials.

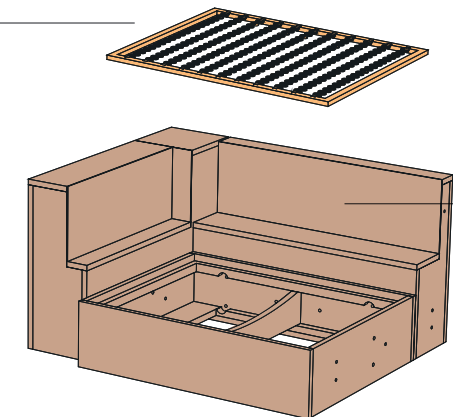

Frame

Solid wood structure from controlled timber with PEFC and FSC certifications.

Casters

Freedom of movement thanks to its discreet hidden casters.

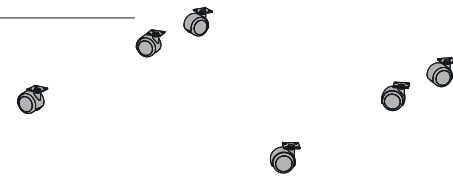

Mix and match all the options available for Savina. You can unleash your imagination to design your bespoke sofa from zero, to best fulfil your requirements or, if you prefer, you can get inspired by a series of pre-defined compositions that will help you bring this collaborative island to life into your projects.

Either way, the final result will be a comfortable sofa that fosters interaction, well-being and productivity, all in one. A singular collaborative piece that is able to add a contemporary twist to homes, workplaces, hotels and high-traffic environments all around the world.

Savina sofa



Savina sofa, Composition 1



Savina sofa, Composition 2



Savina sofa, Composition 3



Savina sofa, Composition 4



Savina sofa, Composition 5



Savina sofa, Composition 6



Savina sofa, Composition 7



Savina sofa, Composition 8



Savina sofa, Composition 9



Savina sofa, Composition 10



Savina sofa, Composition 11



Connectivity



1. Seat socket
2. Power socket, upholstered
3. Powerbox under table

CAMBIO

A minimalist approach

A collection of tables designed by Victor Carrasco, 2022

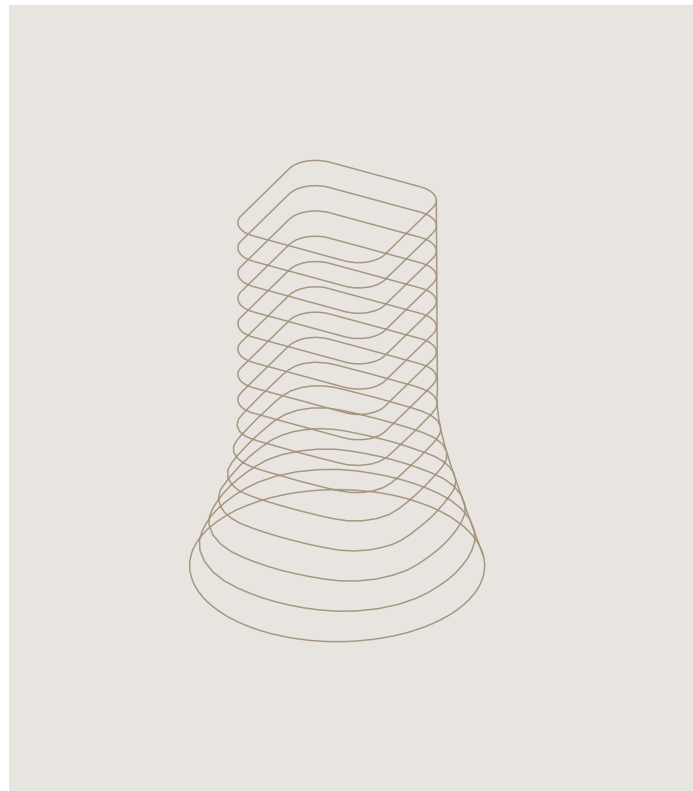

“As the Greek philosopher Heraclitus said, “the only constant in life is change”. The best relationships as well as the finest designs evolve only in a very natural manner. My wish was simple, I allured to transit from a square to a round surface with kindness. This is how Cambio is born. A new collection of central bases to create infinite possibilities for our tables made

for work, homes, or collectivities. An exercise of subtleties to outline a timeless design, timeless and silent as well as iconic thanks to its elegant morphology and its profound message to promote sensible and sustainable changes.”

By Victor Carrasco.



“An exercise of subtleties to outline a timeless design, an elegant game of geometry which promotes sustainable and sensible change phases.”

Featuring Cambio table in H74 | 29,13" Ø70cm | Ø27,55" with black base and black tabletop. Chair is Funda in black by Stefan Diez



Featuring Cambio table in H74 | 29,13" 500x150cm |
196,85"x59,05" with three white bases and white tabletop,
styled with Quadra chairs by Mario Ferrarini

Choose your size,
every dimension is covered

Every dimension is taken into consideration to fulfil every spatial requirement with the Cambio table. A single base can hold round tabletops of up to two meters, acting as a great dining or meeting table for offices, restaurants, hotels and homes. When upgrading to double or triple bases, the possibilities are endless as it takes tabletops of up to 500x150cm. With Cambio, you can always find space for someone else.

H74, triple

*Ready for dimensions up to
500x150 cm | 196,85"x59,05"*



H74, double

*Ready for dimensions up to
300x150 cm | 118,11"x59,05"*

Featuring Cambio tables in diverse sizes, bases and tabletops. From left to right: H74cm | 17,71" and two bases with 300x150cm | 118,11x59,05" tabletop, H74cm | 29,13" and three bases with 500x150cm | 196,85"x59,05" tabletop, H45 | 29,13" and marble tabletop, H74 | 29,13" and wooden tabletop

Beautifully
crafted in wood



MADE FOR WOOD LOVERS

Only timeless materials, which are longlasting and promote sustainable consumption habits such as wood from controlled timber sources are available to assemble each table. Choose wood for an organic aesthetic, the oak tabletop conveys a crafted expression to Cambio and a comforting appeal, creating an authentic gathering point to celebrate, work or dine. A versatile and genuine table made for wood lovers.

Featuring Cambio table H74cm | 29,13" and
Ø150cm | Ø59,05" wooden tabletop. Chairs
are Maarten Plastic



Featuring Cambio table H74cm | 29.13" with double base in black finish, combined with Copa Soft chairs by Ramos & Bassols

Meetings made comfortable with Cambio

The versatility of the Cambio table joins the Viccarbe collection to add innovative working and dining solutions for offices, restaurants, hotels and homes. Its minimalist double base can be easily integrated into meeting, board or conference rooms combined with its oval tabletop, ideal when extra seating is required as there is always room for more.

Featuring Cambio table H74cm | 29,13", with double base in white and oval tabletop in wood. Chairs are Funda by Stefan Diez



DINE OR WORK WITH CAMBIO

The different dimensions and multiple finishes for its tabletop effortlessly integrate Cambio in any working or dining scenario. Great as a bistro table for modern cafés or restaurants, the collection is also a great fit for collaborative or co-working spaces, libraries, and canteens in office, educational or hospitality venues.





A BALANCED TABLE FOR HOMOGENOUS SPACES

Cambio stands in the center of any space, almost like a refined sculpture, silently accomplishing our demands. Its square tabletop makes a great table for quick catch-ups or working solo in the office. Combined with other tabletops of larger dimensions, Cambio offers practical working solutions with a consistent and coherent aesthetic throughout any floor layout.

On the right, featuring Cambio table H74 | 29,13"cm with 70x70cm | 27,55x27,55" tabletop in black finish. Chairs are Maarten with wooden armrests

On the right, Sistema bench as a greeting spot on the front and on the back, Cambio tables combined with Maarten and Season chairs







THE PLACE TO COLLABORATE

For us, a table is so much more than a functional element. It is the heart of the home, the place to gather, celebrate and enjoy. It is the center of the office, the spot to meet, create and innovate. Our mediterranean culture is all about collaborating and sharing, it is the way we connect and bond with others around a table what shapes our lifestyle and forms our character. With its minimalist soul and its geometric lines, Cambio is a great piece to discreetly connect users, fostering collaboration in all its means. Cambio plays its part, leaving space to what truly matters.

Featuring Cambio table H74cm | 29,13" and
Ø150cm | Ø59,05" black tabletop. Chairs are Ears
by Piero Lissoni

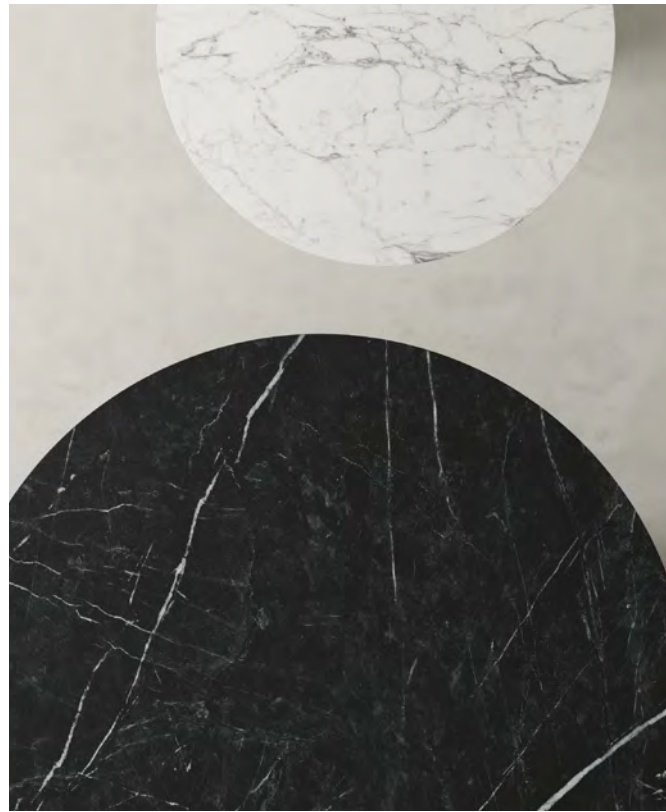

Timeless marble

COMING SOON

Over the years we have been striving to innovate in new materials that conferred a unique allure to our mediterranean furniture. Timeless finishes that contribute to make our pieces very longlasting and aesthetically pleasing.

Soon, you will be able to order marble tabletops for our Cambio collection. Marble is a fine stone, one of the most environmentally friendly materials and enduring surfaces to work or dine. Due to its classic expression, it complements any chair, armchair and sofa in our collection, upgrading the overall design experience.



On the right, featuring Cambio table
H74cm | 29,13" Ø150cm | 59,05" tabletop
in white marble



On these pages, featuring Cambio table H74cm | 29,13" Ø150cm | 59,05" tabletop in black marble and Cambio table H45cm | 17,71" Ø120cm | 47,24" tabletop in white marble

Comfort is assured



On these pages, featuring Cambio table H45cm | 17,71"
Ø120cm | Ø47,24", tabletop in matt oak with a powerbox.
Lounge chairs are Copa with wooden legs, by Ramos & Bassols

Cambio low table with integrated connectivity

CONNECTIVITY

As the rest of the tables in our collection, Cambio also has the possibility of including discreet electrification options to keep users connected on the go. Practical connectivity solutions with a seamless design, perfectly integrated in our ancillary furniture.







TABLETOPS

As to the tabletops, these are available in different shapes such as square, oval, or round, allowing big compositions of up to two meters in diameter or five meters in length, without compromising an ounce of durability and resistance. Finishes range from matt oak, laminates in white or black, polished coatings, a wide chromatic variety of lacquers, to compacts for outdoor use, and the latest incorporation: marble in white or black.

The minimalist table is also available for outdoor spaces, bringing new possibilities to lounge or work. A collection of tables offering kind solutions to work, enjoy and appreciate the alfresco space as an extension of the office. Tables crafted with long-lasting materials and timeless finishes to connect spaces and users, achieving a balanced and homogeneous aesthetic both in and out.

Cambio table moves outdoors

On these pages, featuring Cambio table H74cm | 29,13" Ø100cm | 39,37" outdoor version. Chairs are Maarten Plastic.



Cambio table



Cambio H74 D60cm /
H29.13" D23.62"

Cambio H74 D70cm /
H29.13" D27.55"

Cambio H74 D80cm /
H29.13" D31.49"

Cambio H74 D100cm /
H29.13" D39.37"



Cambio H74 90x90 cm /
H29.13" 35.43"x35.43"

Cambio H74 D150cm /
H29.13" D59.05"

Cambio H74 140x140 cm /
H29.13" 55.11"x55.11"

Cambio H74 D200cm /
H29.13" D78.74"



Cambio double base H74 300x150 cm / H29.13" 118.11"x59.05"

Cambio double base H74 500x150 cm / H29.13" 196.85"x59.05"

Cambio low table



Cambio H48 D60 cm /
H18.89" D23.62"

Cambio H48 D70 cm /
H18.89" D27.55"

Cambio H48 D80 cm /
H18.89" D31.49"

Cambio H48 D100 cm /
H18.89" D39.37"



Cambio H48 D120 cm /
H18.89" 47.24"

Cambio H48 70x70 cm /
H18.89" 27.56"x27.56"

Cambio H48 80x80 cm /
H18.89" 31.49"x31.49"

Cambio H48 90x90 cm /
H18.89" 35.43"x35.43"

Connectivity



1. Pop-up sockets
2. USB port
3. Powerobx
4. Pop-up sockets

ALETA

Elegance in the subtle

Collection designed by Jaime Hayon, 2017



If we look for a leitmotif in the Viccarbe collection, that would be the combination of synthetic structures and extra comfortable seats. The simplicity, the contemporary design of its chairs and armchairs comes from the hand of bases that have the precise material to define the use and the function, free of all useless adornment. On the other hand, comfort comes from subtle details on both the inside and outside of each piece. Aleta was born in this way, achieving a perfect balance capable of fulfilling the creative proposal of Jaime Hayon, and the evolutionary proposal of the Viccarbe collection.

"With the international vision, with the mixture of know-how, and of combining different ideas and dialogues, certain products were released with which we are very satisfied today.

As a designer—just like Viccarbe—I'm very functional. Not minimalist, but simple. (...) With Viccarbe, the idea was to find a mutual language. The turning point has perhaps been found by making a few more expressive forms on the chairs or tables we have made, finding a way, a balance for both. I believe that the real collaboration with companies is this: to find a balance."

"The simplicity, the contemporary design of its chairs and armchairs comes from the hand of bases that have the precise material to define the use and the function, free of all unnecessary adornment."



On this page, a picture of Burin table full black with two Aleta chairs metal base, black structure



Comfort comes from subtle details on both the inside and outside of each piece



On the left page, a picture of Burin table in black with Aleta chair, pyramid swivel base. On this page, Aleta chair, flat swivel base, and Aleta chair pyramid swivel base with casters

On these pages, featuring Trestle table and Aleta chair with swivel flat base

The limits between spaces are blurred. Conventional meeting rooms are no longer the only spaces where teams work to transform organizations. We feel more comfortable in familiar surroundings, in places similar to the living room, where we regain confidence in ourselves and feel like participating. We also feel comfortable in relaxed environments such as a café, where we can hold informal meetings where we can take a stance and strengthen ties with other colleagues in the organization.



Aleta & Work

Office — The Aleta chair was born to materialize the perfect balance between functionality and creativity. Aleta works perfectly in any situation: having lunch in a restaurant, an extended meeting at the office or working from home.



Project on top: Vocoon Headquarters, Cleveland
Interior Design: Vocoon. Pictures: Matthew Carbone

Project on the right: Savills Aguirre Newman
Headquarters - Coffee area

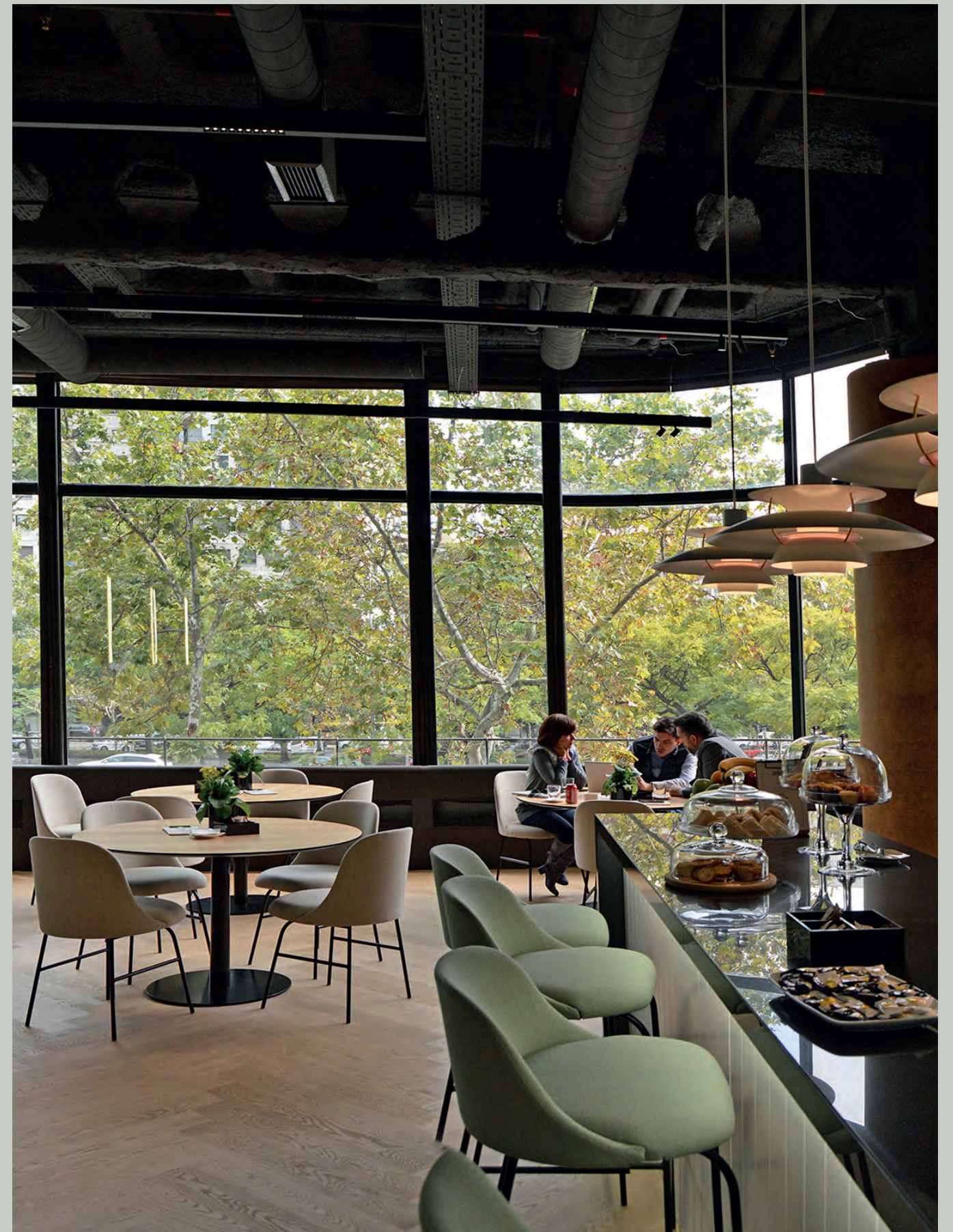

ALETA WOODEN BASE

Warm, elegant, contemporary... The versatility of a chair does not only lie in its initial design. It also lies in the possibility of incorporating different finishes in it. Aleta and its wooden base allow us to play with ambiguity. They give us the possibility to create multipurpose spaces where we are not limited by the use, but inspired by the warmth of the finishes. In this case, it does not matter where we live our day to day life, but the comfort with which we approach it.



On these pages, featuring Burin table and Aleta chair with wooden base

Unwind Hotel Otaru, (Japan)

Hospitality — Unwind Otaru represents the renovation of an old building located in the prefecture of Hokkaido, north of Japan. Its vintage aesthetic combines perfectly with the contemporary furniture and finishes chosen for the new layout. As with the Aleta collection, achieving the right balance is fundamental.



Project on these pages: Unwind Hotel Otaru, Japan
Interior Design: LINE-Inc. Pictures: Kenji Masunaga, Kozo Takayama
Special thanks: Interiors Inc



Projects on the left page: Tago Mago Restaurant, Valencia.

Projects on the right page: La Chipirona Restaurant, Valencia by La Galería Estudio. Picture: Ángel Segura





Projects on these pages: La Chipirona Restaurant,
Valencia by La Galería Estudio. Picture: Ángel Segura



Projects on the left page: The Härg, Estonia. Interior design: Ace of Space + Aap Piho. Dealer: Studio Living. Photographer: Terje Ugandi

Projects on the right page: La Cabra Restaurant, Madrid. Interior Design: Mecanismo. Photographer: Kavi Sánchez

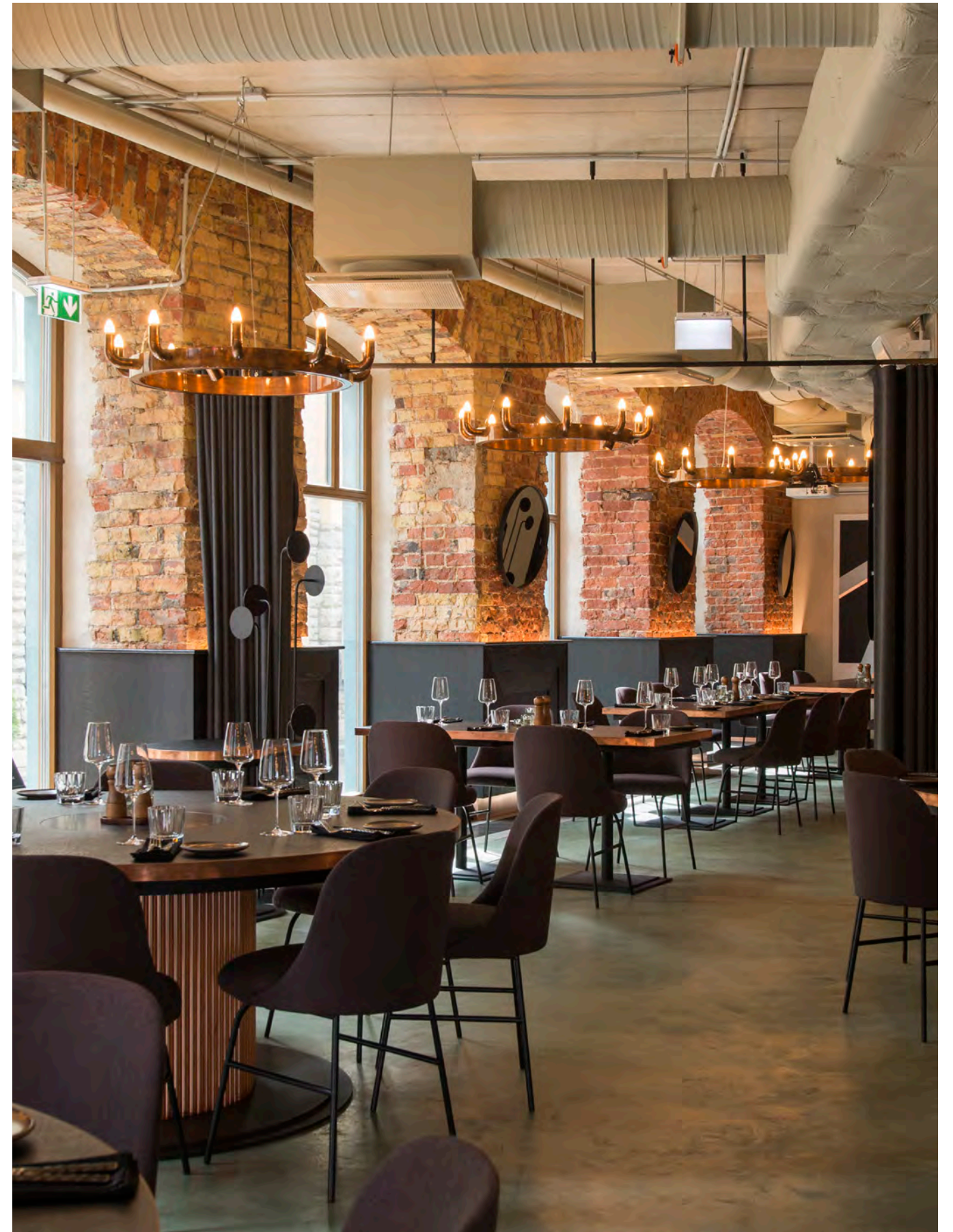

Projects on these pages: Centre Pompidou Café
Le Central, Paris. Project: Hayon Studio
Pictures (interiors): Nienke Klunder

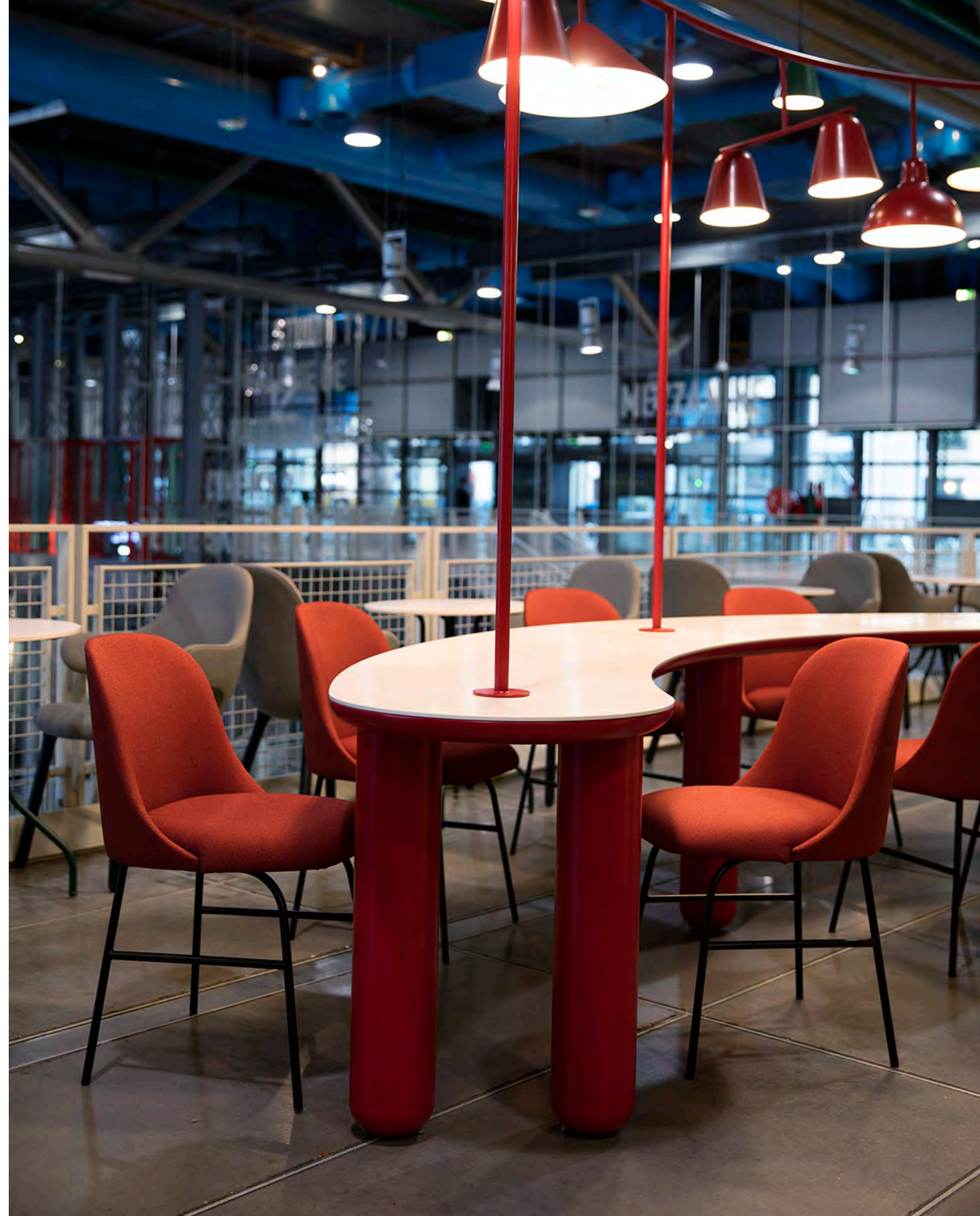



Project on these pages: Reinassance hotel, Barcelona





Aleta Stool



"If we look for a leitmotif in the Viccarbe collection, this would be the combination of synthetic structures and extra comfortable seats."

Project: Regus Spaces, Belvedere
Interior Architect: D&P Associates



Project on the left: Spaces Coworking
Wai Yip Street, Hong Kong
Interior design: D&P Associate

Project on the right: AMGEN HQ
Project: The A&M Group



Project on these pages: Goutal flagship store, Hong Kong
Project: VIA Architecture Limited
Photography: VIA Architecture Limited, Marketing Team
Archetypal Limited



Aleta stool at the office

Workspaces — The talent and energy of Jaime Hayon has conveyed to the latest additions of the collection. The Aleta stool is contemporary, warm, and elegant and its stimulating finishes will convert any office space layout.



Project on top: Mc Donald's Headquarters, Chicago
Architecture & Interior Design: Sterling Bay + Gensler
- IA Interior Architects y Studio O+A
Pictures: Mc Donald's

Project on left: Regus Spaces, Belvedere
Interior Architect: D&P Associates

Project: HucCo Coworking Space, New York. Interior
Design: Christina Michelle Interiors.
Photography: Ball & Albanese



An elegant stool to
add character into
any room



Project: Tago Mago Restaurant, Valencia



Project: VIBIA Headquartes, Barcelona
Pictures: Fernando Aida

Aleta *Lounge Chair*

2017 — How to express a lot through a simple piece of furniture? The successful Aleta collection fuses functionality with comfort, rigorous lines with creativity. As in the entire Viccarbe collection, nothing is static: Metal or wooden structure? Seats with or without armrests? If creativity taught us something, it is that we should never give up freedom.



If creativity
taught us
something, it is
that we should
never give up
freedom



On the left, Aleta Lounge chair with brass structure. On this page Aleta Lounge chair and Shape low table



Pictures on these pages: Vertisol Showroom,
Madrid. Project: Odosdesign
Pictures: Javier Guerrero

Aleta lounge chair



Aleta Lounge Chair
metal base



Aleta Lounge Chair
wooden base



Aleta Lounge Chair
metal base & armrests



Aleta Lounge Chair
wooden base & armrests

Aleta stool



Aleta bar stool



Aleta high backrest
bar stool



Aleta swivel
bar stool



Aleta swivel bar stool
high backrest



Aleta swivel bar stool
& armrests



Aleta counter stool



Aleta counter stool
high backrest & armrests



Aleta swivel
counter stool



Aleta swivel counter stool
& high backrest



Aleta swivel counter stool
high backrest & armrest

Aleta low table



Aleta low table

Aleta chair



Aleta chair
metal base



Aleta chair
metal base & armrests



Aleta chair
metal base



Aleta chair
metal base & armrests



Aleta chair
wooden base



Aleta chair
wooden base & armrests



Aleta chair
swivel base



Aleta chair
swivel base & armrests



Aleta chair
pyramid swivel base



Aleta chair
pyramid swivel base & armrests



Aleta chair
flat swivel base



Aleta chair
flat swivel base & armrests



Aleta chair
pyramid swivel base & casters



Aleta chair
pyramid swivel base
with casters & armrests



Aleta chair
five casters base



Aleta chair
five casters base & armrests

BURIN

Shape & character

Table designed by Patricia Urquiola, 2018

“There is a fine line between the ambition to achieve iconic design and functional design at the same time, a line between the personality of the author and the role that a table should play in a collective or private space.”

The rules of the game are broken. The boundaries between spaces are blurred. What in the past we were used to understand as work spaces, today have become friendly living rooms or quiet libraries.

The reference boutique hotels and cafés want to be co-working spaces. Households prepare for co-living. And—above all—they take values such as flexibility for granted.

But in all these spaces, in all these places for people, there is a value sine qua non to the condition of the human being. In all of them there is the search for well-being, self-realization and freedom of expression. In all of them, one expects to experience the feeling of comfort. There is therefore a fine line between

the ambition to achieve iconic design and functional design at the same time, a line between the personality of the author and the role that a table should play in a collective or private space.

With Patricia Urquiola, we learned to look for new ways of constructing, to make use of materials that the classic furniture industry would not have contemplated. We also learned to project a continuity within the collection. In Burin's case, it would happen at the time when we were expanding an existing family, but also with the use of rotational polyethylene in the manufacture of its base. The moment when we opened the doors to this material comes to mind: 2006 gave us the Last Minute stool and its seat in this same rotomolded polyethylene.



On this page set of a Burin table with matt oak table top and black base with Maarten Plastic chairs, sled base

DOUBLE BURIN

It is fascinating how the use of an unusual component has managed to democratize this centrally based table. However, above all, it is interesting how it has happened without losing an ounce of character and differentiation. By giving the possibility of combining its base with more sophisticated boards, we manage to maintain the balance that is created between durability and elegance, no matter if it is in its single, double or triple base version.



On this page, a set of a double Burin table lacquered in black with Quadra chairs in ash



SUBTLE CONNECTIVITY

Additionally, Burin can include electrification systems in a discreet and fully integrated manner, an extra dose of functionality and aesthetics for meeting spaces and large conference rooms.

On the left page, a set of a Burin table lacquered in black with Copa cantilever chairs. On this page, a Burin triple table in black finish with Maarten Plastic chairs, pyramid base and brick seats

An environmentally



friendly process

Rarely does the industrial process of a design make big headlines. However, from the perspective of sustainability, this is precisely the benefit of a design. Industrialization has given us the possibility to make life easier for society and to share our Mediterranean lifestyle. It has opened the door to innovative product categories capable of responding to new contexts, behaviors and moments with the best designers and architects in the world. We learned about artisan processes but, over the years, we found the opportunity to evolve to find ways to create that are more efficient and sustainable over time, ways which are more respectful of the environment.

In the case of Burin, its base is made through a mold in which the pellets are rotated and gradually molded into a base that will later not only be resistant and durable over time for decades, but also totally recyclable. Beauty is, without a doubt, on the inside.

Pictures during the manufacturing process of a Burin table

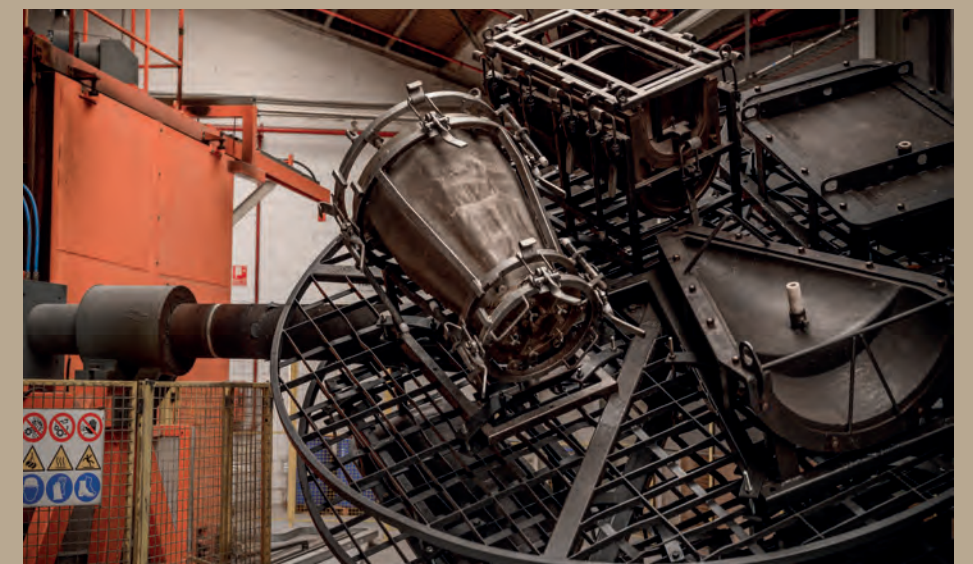

Burin & Food

Restaurants — Thanks to its base, Burin is a table especially suitable for *hospitality* spaces: hotels, bistros, coffee shops... It is easy to clean and very resistant to the course of time.



In these pages, a picture of Burin tables with square matt oak table top and taupe base combined with four-legged wooden Copa chairs



Burin table & Burin Mini



Burin H74 70x70 cm /
H29.13" 27.56"x27.56"



Burin H74 80x80 cm /
H29.13" 31.50"x31.50"



Burin H74 D70 cm /
H29.13" D27.56"



Burin H74 D120 cm /
H29.13" D47.24"



Burin H102 80x80 cm /
H40.16" 31.50"x31.50"



Burin H102 D80 cm /
H40.16" D31.50"



Burin H74 140x140 cm /
H29.13" 55.11"x55.11"



Burin H74 100x100 cm /
H29.13" 39.37"x39.37"



Burin Mini H50 - H55 cm /
H19.69" - H21.95"



Burin Mini H50 + 10 cm (handle) /
H19.69 + 3.94" (handle)

Burin table



Burin double base H74 L240 cm / H29.13" L94.48"
with powerbox



Burin double base H74 L240 cm / H29.13" L94.48"



Burin central base H74 D150 cm / H29.13" D59.05"
with pop-up sockets



Burin triple base H74 L350 cm / H29.13" L889"
with pop-up sockets

Connectivity

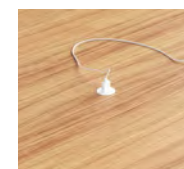

1. Pop-up sockets
2. USB port
3. Powerbox
4. Pop-up sockets

SOLAR

Reach for the Sun

Table designed by Marc Krusin, 2021



Solar is the result of our relentless search to attain an added value in every new project that we launch at Viccarbe.

A disruptive, out-of-the-box vision, which analyzes human behaviors yet to be resolved, and creates new collaborative models for both Indoor and Outdoor. Solar enhances privacy and collaboration, physical distance, and proximity. A great

all-rounder that connects and brings spaces together. A mix of options due to the simple and sculptural proposal of a swivel table and an integrated seat, that rotates according to the user's requirements when needing to move towards a co-worker or when demanding a dose of sunshine, as an elegant sunflower, to rejuvenate and switch off after several hours indoors.

"A disruptive, out-of-the-box vision, which analyzes human behaviors yet to be resolved, and creates new collaborative models for both Indoor and Outdoor."



OUTDOOR VERSION

Solar for outdoor has a metal structure and a compact tabletop, and its seat can be made in compact or upholstered in any of the available outdoor fabrics.



On these pages, featuring Solar table outdoor version with white structure and upholstered seat

Solar allows you to spin in search of sunlight, a colleague or some privacy



On these pages, Solar with black structure, stained tabletop in cognac and upholstered seat

Privacy

*Retreat outdoor with Solar to disconnect, work, dine or enjoy the alfresco area.
Privacy is always guaranteed.*

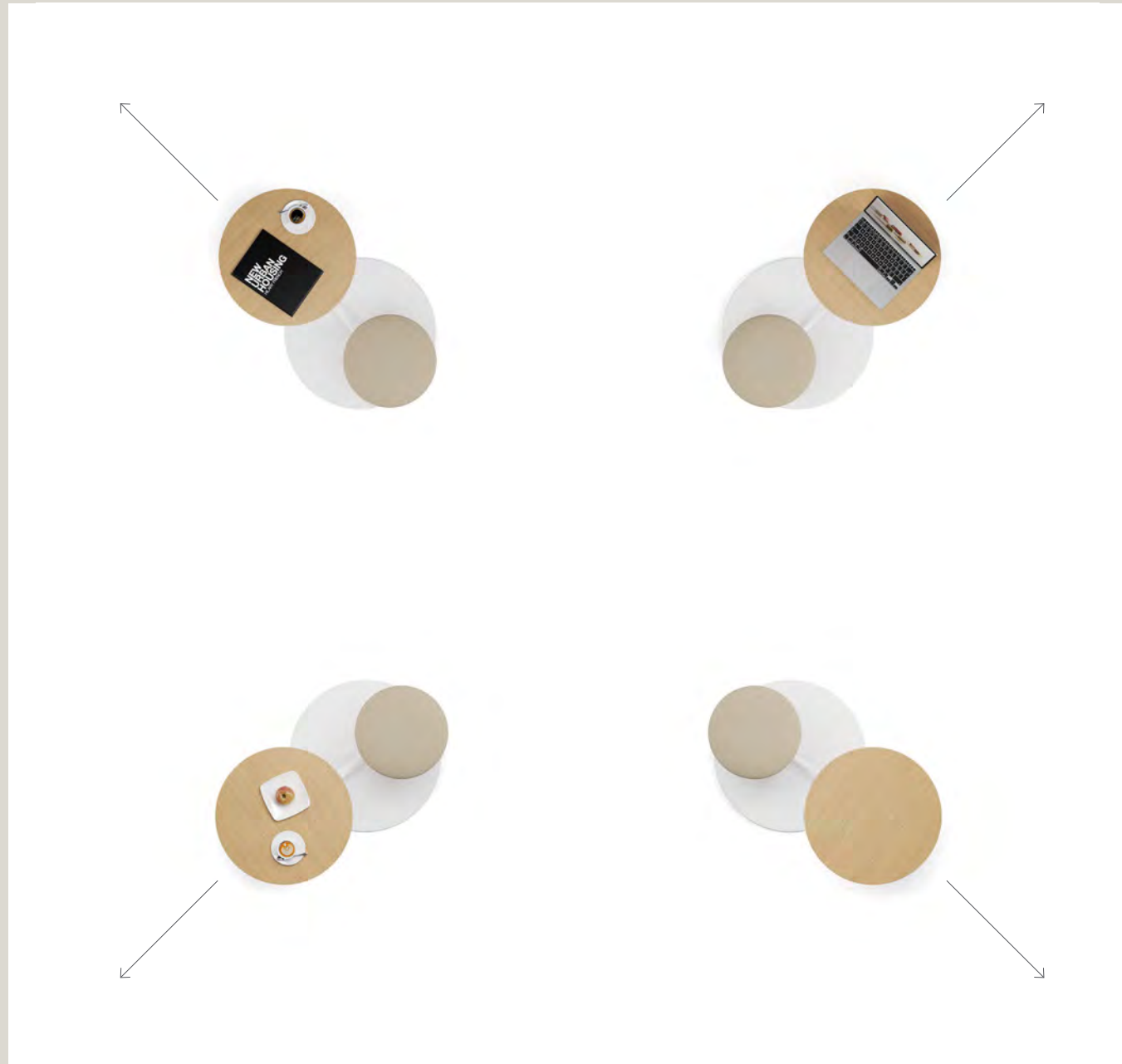

Collaboration

Choose your side with Solar, a clever piece to foster collaboration in team meetings, promote communication and enhance concentration.

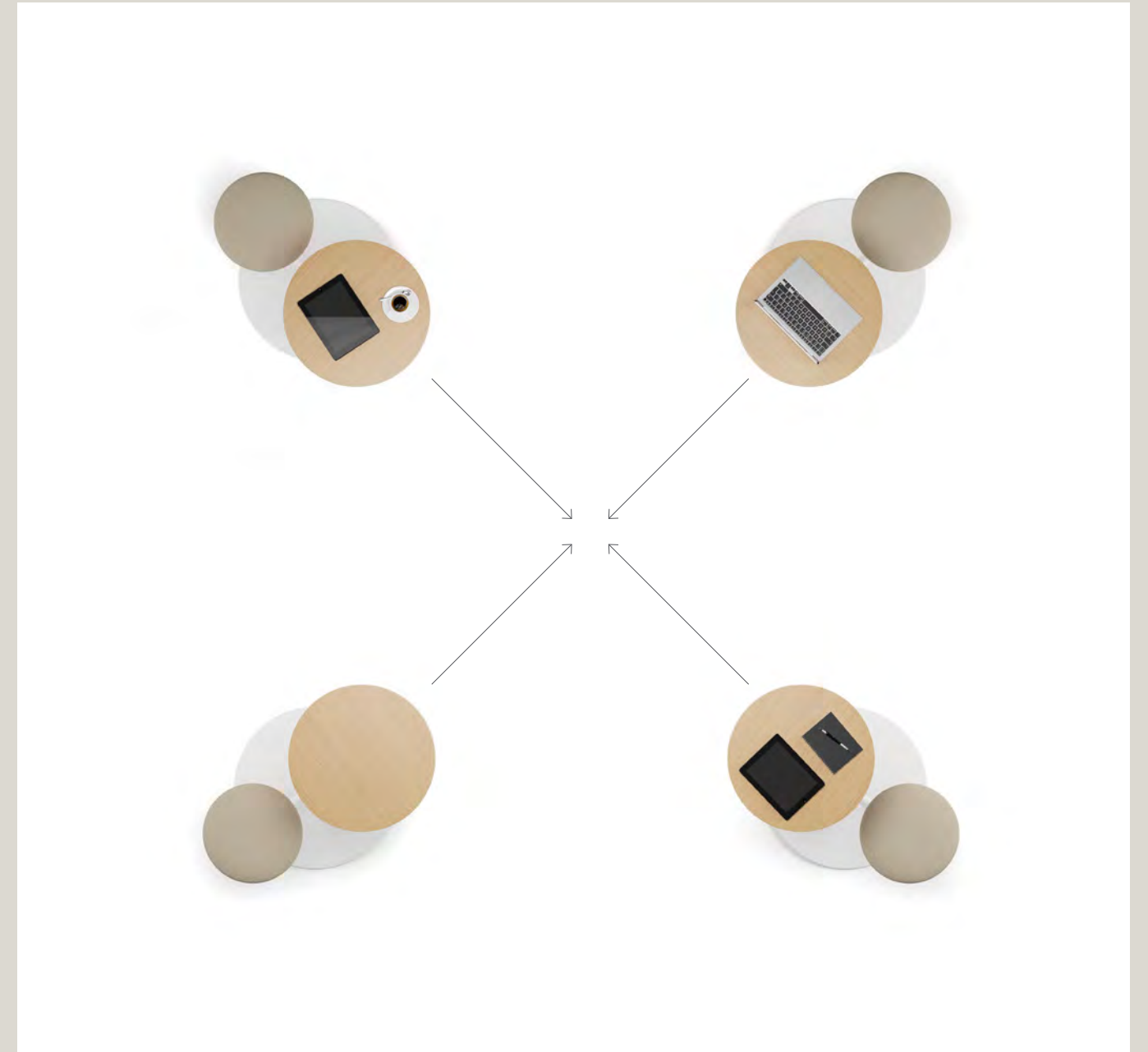

CORPORATE

The exterior is now an extension of the office space. Solar table opens new territories and possibilities to take advantage of the outdoor scene. A place to work, share and create.



On these pages, featuring Solar table outdoor version in white finish



FLEXIBILITY IS COVERED

The disruptive table promotes flexibility in and out. No matter the location, Solar table has got it covered.

On these pages, featuring Solar table outdoor version with black tabletop, white structure and upholstered seat



EDUCATIONAL

Solar table enhances focused and independent work but at the same encourages collaboration thanks to its swivel base. A great flexible piece for classrooms, universities and modern conference rooms.

On these pages, Solar with white structure, stained tabletop in matt oak and upholstered seat

The Battery Pack provides up to 8 days of autonomy



An autonomous & secure USB charging station is available. With the USB pack, the charging unit can be easily installed under the tabletop. 2 USB ports allow fast charging of phones, tablets, power banks and other devices. The Battery Pack is powered by a 15 Ah battery which provides up to 8 days of autonomy depending on its use.

On the left page, Solar table with the charge system battery pack

Charging devices



The Charging tray allows 4 batteries to be recharged simultaneously in 7 hours. It can be used flat or fixed on a wall.



A magnetic key allows you to unlock the battery and extract it in a jiffy to recharge it.



The Battery pack has been designed for professional use. Its reinforced case and its IP 65 certification allow it to be used both indoors and outdoors.

Mix and match all the options available for Solar. You can unleash your imagination to design your bespoke sofa from zero, to best fulfil your requirements or, if you prefer, you can get inspired by a series of pre-defined compositions that will help you bring this collaborative island to life into your projects.

Either way, the final result will be a comfortable table that fosters interaction, well-being and productivity, all in one. A singular collaborative piece that is able to add a contemporary twist to homes, workplaces, hotels and high-traffic environments all around the world.

Solar table



Solar, white seat and compact laminate tabletop



Solar, black seat and compact laminate tabletop



Solar, upholstered seat and cognac tabletop



Solar, upholstered seat and matt oak tabletop

