

QT Chair

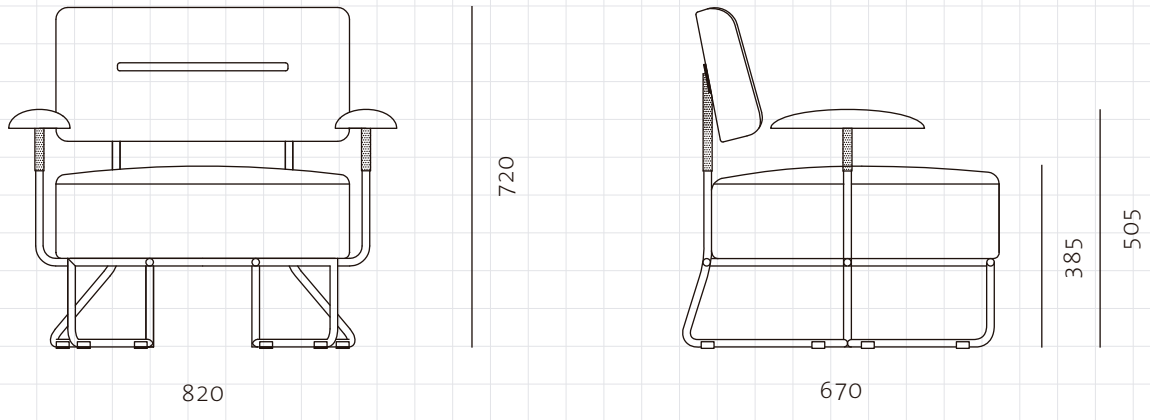

CODE

QT-S121

DIMENSIONS

W820 x D670 x H720mm

NET WEIGHT

Seating height: 385mm

ENVIRONMENT

19.0 kg

MATERIALS

Indoor

Powder coated steel frame, Brass plated stainless steel, Solid wood armrest, Upholstery

*Please refer to website or contact your local representative for complete material swatches.

SHIPPING

Package	Assembled		
Package Qty	1 pcs/box		
Packaging	Measurement (mm)	Volume (cbm)	Gross Weight (kg)
FCL	W885 x D735 x H805	0.52	26.0
LCL/AIR	W905 x D755 x H900	0.61	33.0