

Mandarin Lounge Chair

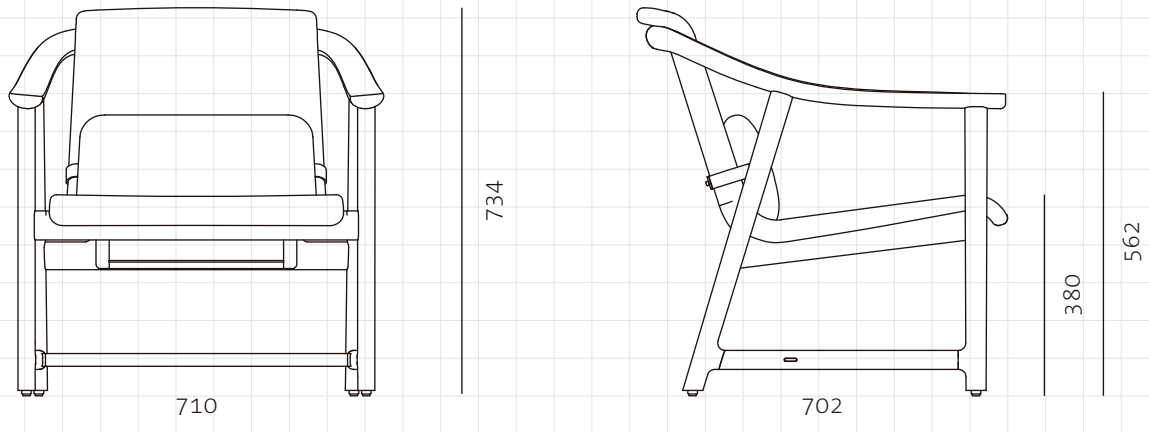

CODE

MA-S111

DIMENSIONS

W710 x D702 x H734mm

NET WEIGHT

Seating height: 380mm

ENVIRONMENT

12.8 kg

MATERIALS

Indoor

Solid wood frame, Brass plated stainless steel, Upholstered fibreglass seat shell,
Upholstered cushion

*Please refer to website or contact your local representative for complete material swatches.

SHIPPING

Package	Assembled		
Package Qty	1 pcs/box		
Packaging	Measurement (mm)	Volume (cbm)	Gross Weight (kg)
FCL	W775 x D767 x H819	0.49	20.0
LCL/AIR	W795 x D787 x H914	0.57	27.0