

Mandarin Dining Chair

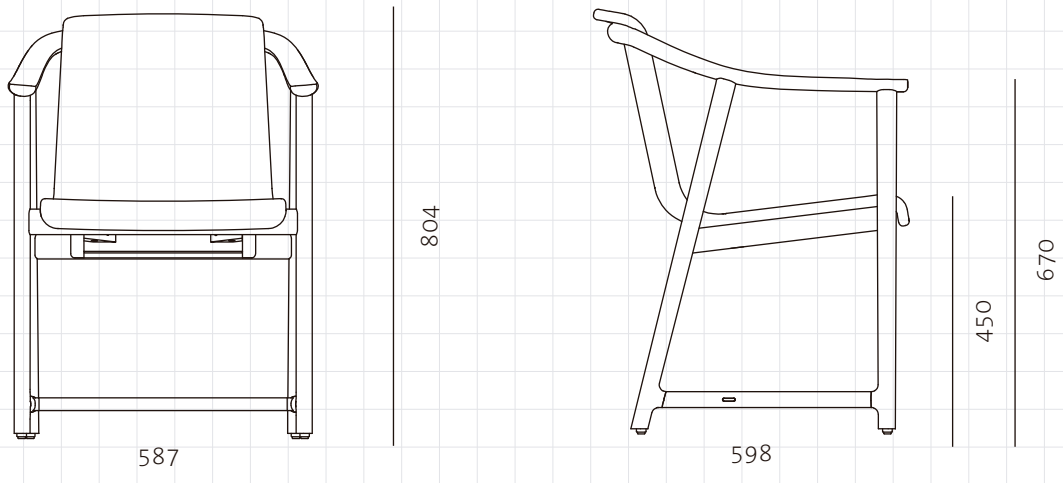

CODE

MA-S211

DIMENSIONS

W587 x D598 x H804mm

NET WEIGHT

Seating height: 450mm

ENVIRONMENT

9.7 kg

MATERIALS

Indoor

Solid wood frame, Brass plated stainless steel, Upholstered fibreglass seat shell

*Please refer to website or contact your local representative for complete material swatches.

SHIPPING

Package	Assembled		
Package Qty	1 pcs/box		
Packaging	Measurement (mm)	Volume (cbm)	Gross Weight (kg)
FCL	W680 x D680 x H870	0.40	14.0
LCL/AIR	W720 x D720 x H960	0.50	22.0