

Lunar Side Table

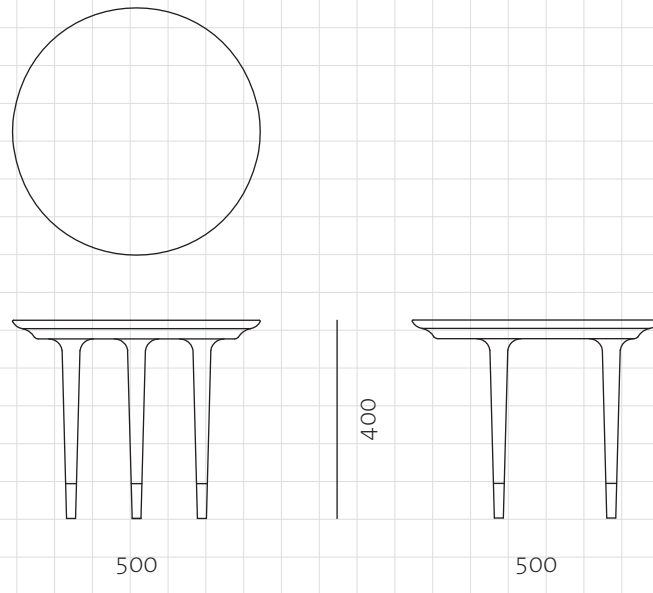

**CODE** LN-T110-500  
**DIMENSIONS** W500 x D500 x H400mm

**NET WEIGHT** 5.5 kg  
**ENVIRONMENT** Indoor

**MATERIALS** Solid wood legs, Veneer laminate top, Brass plated stainless steel  
\*Please refer to website or contact your local representative for complete material swatches.

SHIPPING	Package	Knock Down		
	Package Qty	2 pcs/box		
Packaging	Measurement (mm)	Volume (cbm)	Gross Weight (kg)	
FCL	W580 x D580 x H120	0.04	6.0	
	W303 x D115 x H452	0.02	3.0	
LCL/AIR	W600 x D600 x H140	0.05	10.0	
	W303 x D115 x H452	0.02	3.0	