

Lunar Lounge Chair Small

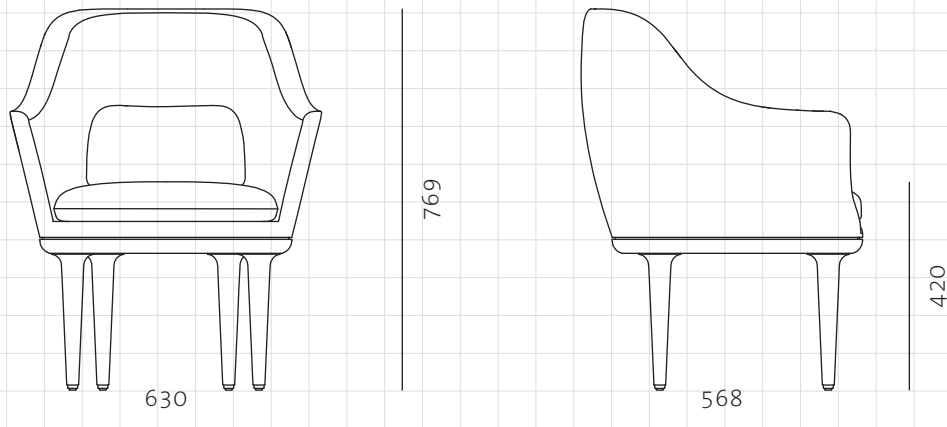

CODE

LN-S111-S

DIMENSIONS

W630 x D568 x H769mm

NET WEIGHT

Seating height: 420mm

ENVIRONMENT

12.5 kg

MATERIALS

Indoor

Solid wood legs, Upholstered moulded foam frame, Upholstered cushion

*Please refer to website or contact your local representative for complete material swatches.

SHIPPING

Package	Assembled		
Package Qty	1 pcs/box		
Packaging	Measurement (mm)	Volume (cbm)	Gross Weight (kg)
FCL	W695 x D633 x H854	0.38	19.0
LCL/AIR	W715 x D653 x H949	0.44	24.0