

## Lunar Lounge Chair Large

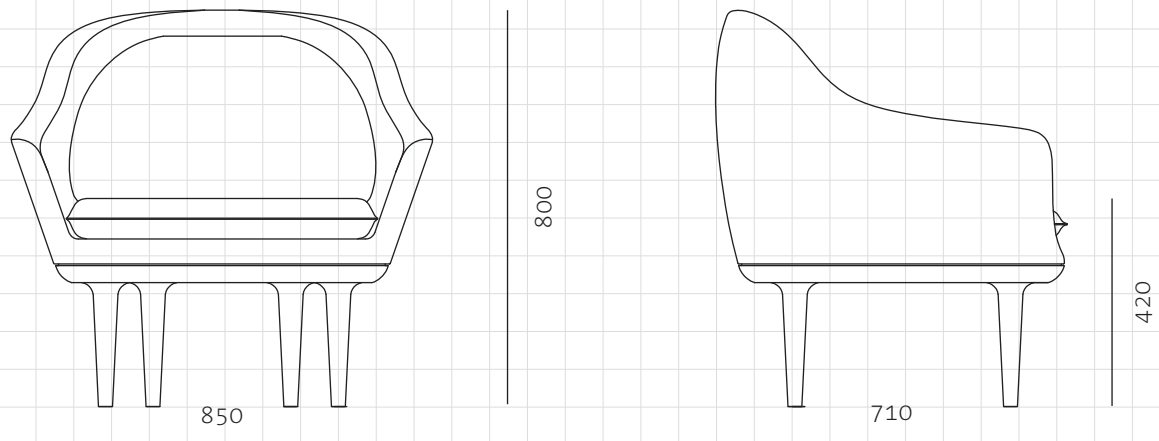

### CODE

LN-S111-L

### DIMENSIONS

W850 x D710 x H800mm

### NET WEIGHT

Seating height: 420mm

### ENVIRONMENT

23.5 kg

### MATERIALS

Indoor

Solid wood legs, Upholstered moulded foam frame, Upholstered cushion

\*Please refer to website or contact your local representative for complete material swatches.

### SHIPPING

<b>Package</b>	Assembled		
<b>Package Qty</b>	1 pcs/box		
<b>Packaging</b>	<b>Measurement (mm)</b>	<b>Volume (cbm)</b>	<b>Gross Weight (kg)</b>
<b>FCL</b>	W915 x D775 x H885	0.63	31.0
<b>LCL/AIR</b>	W935 x D795 x H980	0.73	40.0