

Lzf

PART TWO

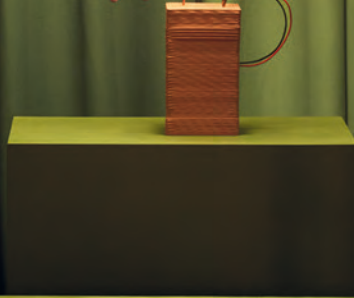

PART TWO
M to Z



WOOD TOUCHED
BY **LIGHT**



Maruja

Suspension

Designed by:
Gaspacho Studio

An original self-assembly pendant, Maruja was designed by the fresh-faced Gaspacho Studio- it is LZF's first flat-pack fixture. A contemporary lamp, Maruja's design is simultaneously unfussy and decorative. Maruja is a name whose origins lie in Galicia, and signifies both femininity and strength.

The do-it-yourself Maruja is packaged with all the components needed to assemble the lamp: wood veneer strips (in several sizes), a circular frame, and pins. Maruja is easily constructed, without the need for any tools or adhesives. Using a pin, each wooden strip is clipped onto the circular frame-insert a light bulb, and you will have created an elegant, handmade lamp. The wood veneer strips hang and move freely, and when illuminated, Maruja sparkles with life.

- **MARUJA - SUSPENSION**
33 Pale Rose Wood Veneer.



Photography: Jara Varela

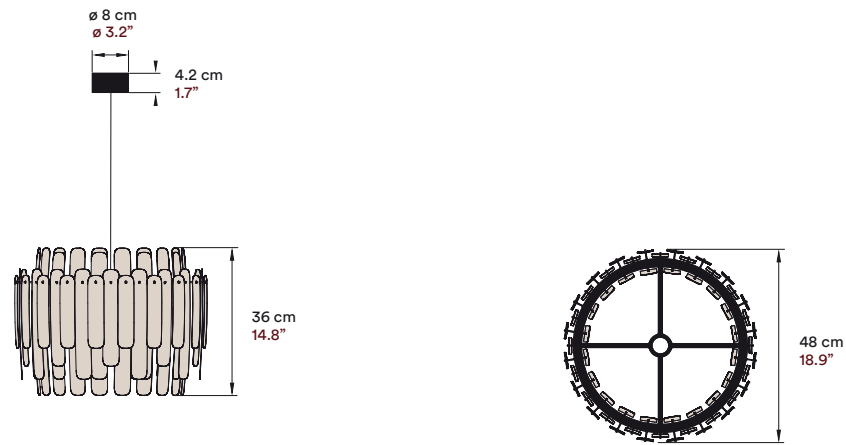

MATERIALS & COMPONENTS

Wood Veneer Shade

Nickel Metal Frame

Metal Canopy

Electrical Cable
2,5 m drop 8 ft drop

LIGHT SOURCE

220 - 250V Class I
Bulb E27

120V
Bulb E26

FINISHES

WOOD VENEER COLOURS

- 20 Ivory White
- 21 Natural Cherry
- 22 Natural Beech
- 24 Yellow
- 29 Grey
- 25 Orange
- 33 Pale Rose
- 26 Red
- 34 Sea Blue
- 28 Blue

METAL COLOURS

- BK-Matte Black
- NI-Nickel
- WH-Matte White



Go to web



● MARUJA - SUSPENSION
21 Ivory White Wood Veneer.

MINIMIKADO



MiniMikado

Suspension

Designed by:
Miguel Herranz

• **MINIMIKADO - SUSPENSION**
21 Natural Cherry Wood Veneer.

The Mikado light takes its names from the classic pick-up-sticks game, where sticks are bundled together and when released, fall in a circular jumble. A radiant light, Mikado's wood veneer strips spread outwards, in a manner evocative of a bird's plumage. Cleverly engineered, the Mikado's form is both chaotic and harmonious at the same time.

Designed by Miguel Herranz, the Mikado is a free spirit, possessing an air of nonchalance and a teasingly impish swagger. It is a light whose profile is like a coruscating kaleidoscope of pattern.

• **MINIMIKADO - SUSPENSION**
20 Ivory White Wood Veneer.

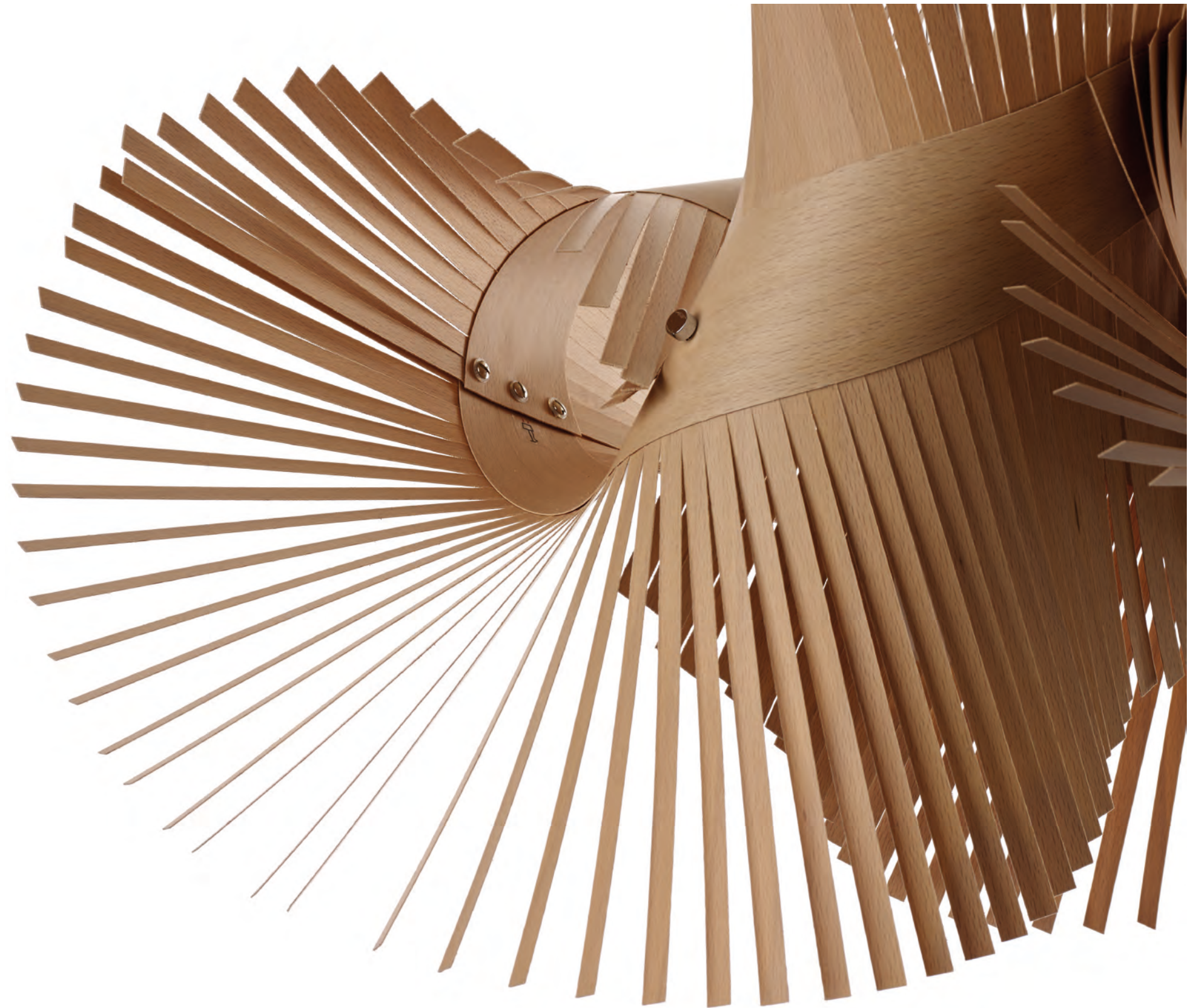

● **MINIMIKADO - SUSPENSION**
22 Natural Beech Wood Veneer.

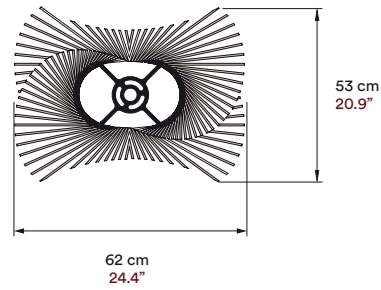
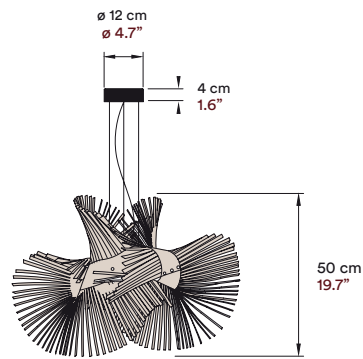

MATERIALS & COMPONENTS

Wood Veneer Shade

Metal Structure & Canopy

3 Stainless Steel Cables
2,5 m drop 8 ft drop

Transparent Electrical Cable
2,5 m drop 8 ft drop

LIGHT SOURCE

220 - 250V Class I
Bulb E27

120V
Bulb E26

FINISHES

WOOD VENEER COLOURS

- 20 Ivory White
- 21 Natural Cherry
- 22 Natural Beech
- 24 Yellow
- 25 Orange
- 26 Red
- 28 Blue
- 29 Grey
- 33 Pale Rose
- 34 Sea Blue

METAL COLOUR

- NI-Nikel

AWARDS



DESIGN PLUS

Chicago

Frankfurt



Go to web



Photography: Jara Varela

● MINIMIKADO - SUSPENSION
24 Yellow Wood Veneer.

NEW



New Wave

- NEW WAVE - SUSPENSION
28 Blue & 24 Yellow Wood Veneer.

Suspension

Designed by:
Ray Power

New Wave comprises of two interlocking interior and exterior wood veneer sheets. Differing in colour to the exterior sheets, the interior sheets's edge juts out, creating a clever design feature that enhances the New Wave's profile. The resulting composition is well-proportioned and fluid, giving the New Wave a smooth, free-flowing countenance.

NEW

NEW WAVE

SUSPENSION

RAY POWER

LED

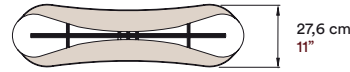
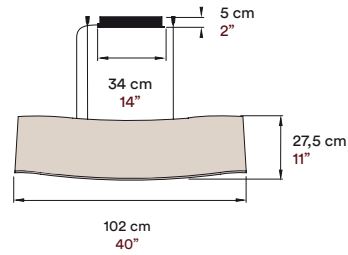

BULBS

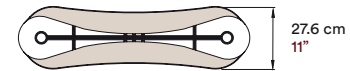
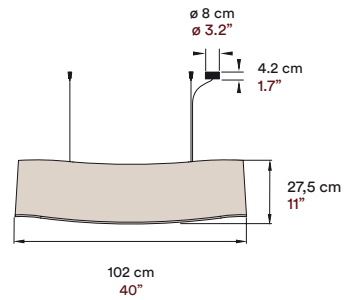

MATERIALS & COMPONENTS

Wood Veneer Shade

White Metal Interior Structure

Metal Canopy

4 Stainless Steel Cables

2,5 m drop 8 ft drop

Transparent Electrical Cable

2,5 m drop 8 ft drop

LIGHT SOURCE

120 - 277V
Dimmable Integrated LED

Class I CE

or
220 - 250V
2 Bulbs E27

120 - 277V
Dimmable Integrated LED

UL US

or
120V
2 Bulbs E26

FINISHES

RECOMMENDED WOOD VENEER COLOUR COMBINATIONS

Exterior

21 Cherry

26 Red

28 Blue

Interior

20 Ivory White

24 Yellow

24 Yellow

METAL CANOPY COLOUR

NI-Nikel

AWARDS



Chicago



Go to web

- **NEW WAVE - SUSPENSION**
28 Blue & 24 Yellow Wood Veneer.



- **NEW WAVE - SUSPENSION**
21 Natural Cherry & 20 Ivory White Wood Veneer.

- **NEW WAVE - SUSPENSION**
26 Red & 20 Yellow Wood Veneer.



N

U

T



Nut

Suspension

Designed by:
Ray Power

Nut is the Valencian word for 'knot' and is thus the perfect name for this delightful, twisting pendant designed by Ray Power. Reminiscent of a granny knot, the Nut lamp's fetching form is made by tying a knot (in a manner of speaking): it is the result of twisting and looping a piece of wood veneer.

- **NUT - SUSPENSION**
22 Natural Beech Wood Veneer.

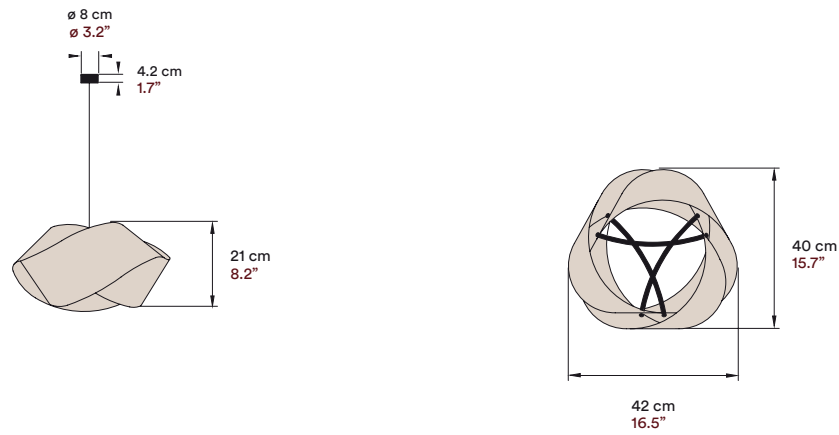

MATERIALS & COMPONENTS

Wood Veneer Shade

Metal Tripod & Canopy

Electrical Cable
2,5 m drop 8 ft drop

LIGHT SOURCE

220 - 250V Class I 
Bulb E27



120V 
Bulb E26

FINISHES

WOOD VENEER COLOURS

-  20 Ivory White
-  21 Natural Cherry
-  22 Natural Beech
-  24 Yellow
-  29 Grey
-  25 Orange
-  33 Pale Rose
-  26 Red
-  34 Sea Blue
-  28 Blue

METAL COLOURS

-  BK-Matte Black
-  NI-Nickel
-  WH-Matte White



Go to web

- **NUT - SUSPENSION**
20 Ivory White Wood Veneer.

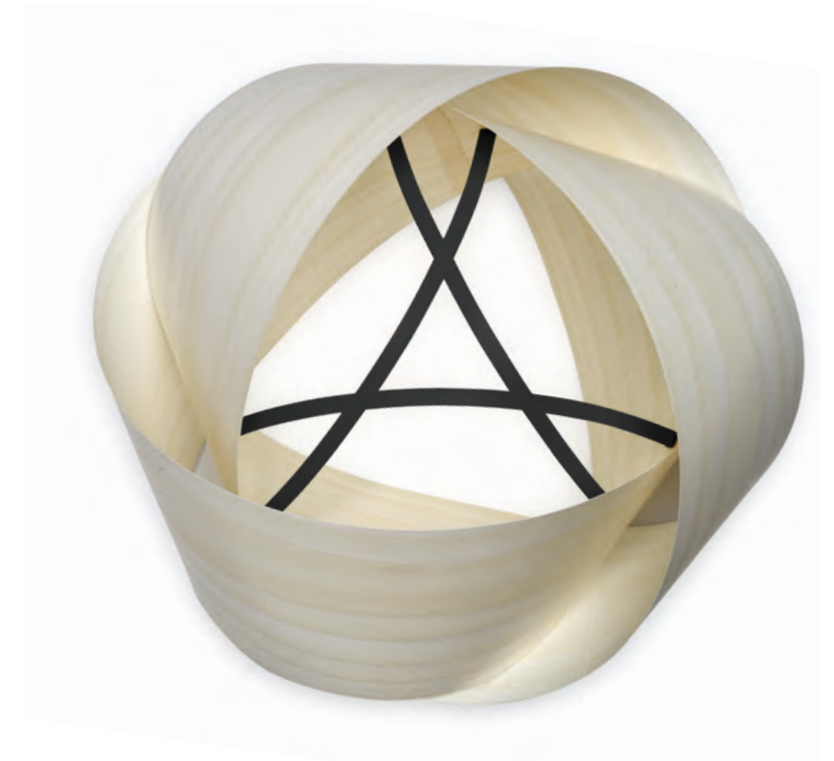

O

B

R

Orbit

Wall

Designed by:
Miguel Herranz

With its thoughtful air, the ovalesque Orbit light will decorate any wall with quiet self-assurance. Created by Spanish designer Miguel Herranz, Orbit is an unfussy lamp whose shape is handmade by twisting a piece of wood veneer. Two designs are feasible, depending on the direction of torsion—that is how the wood veneer is twisted.

Light from the Orbit is diffused both upwards and downwards via its two apertures and an inner glow radiates outwards, accentuating the beauty of the timber veneer grain. In essence, just as the earth is in orbit around the sun, light is in orbit around the Orbit.

● ORBIT - WALL | 20 Ivory White Wood Veneer.

T



Photography: Santiago Relanzón

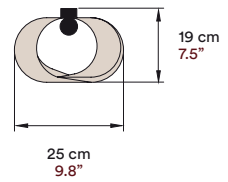
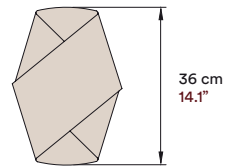

MATERIALS & COMPONENTS

Wood Veneer Shade

White Metal Back Plate

LIGHT SOURCE

220 - 250V
Bulb E27

Class I 

120V
Bulb E26



FINISHES

WOOD VENEER COLOURS

- | | | | |
|---|-------------------|---|------------------|
|  | 20 Ivory White |  | 22 Natural Beech |
|  | 21 Natural Cherry |  | 29 Grey |
|  | 24 Yellow |  | 33 Pale Rose |
|  | 25 Orange |  | 34 Sea Blue |
|  | 26 Red |  | 28 Blue |



Go to web



• ORBIT - WALL
20 Ivory White Wood Veneer.



Photography: Ángel Segura

Oh!Line

Medium & Large
Suspension

Designed by:
Burkhard Dämmer
& Mariví Calvo

Imagine sitting beneath a halo of light. This is the effect created by Oh!Line, a svelte circle of light. Designed by Mariví Calvo & Burkhard Dämmer, Oh!Line is available in two sizes: medium and large suspension.

With its slim form, wood veneer, dimmable LED, and light-filtering diffuser, Oh!Line radiates warmth and elegance. Light from the ring-shaped Oh!Line provides a relaxed ambience and a focused glow.

- OH!LINE - MEDIUM & LARGE SUSPENSION
20 Ivory White Wood Veneer.





Photography: Ángel Segura

● OH!LINE - MEDIUM & LARGE SUSPENSION | 20 Ivory White Wood Veneer.

MEDIUM

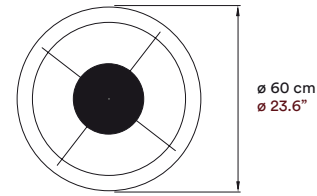
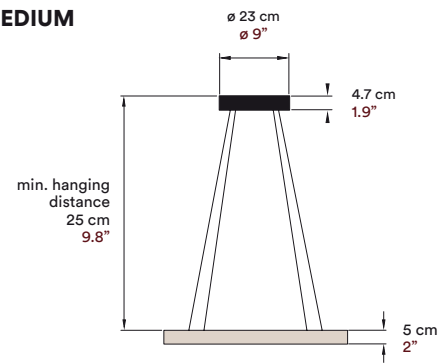

LARGE

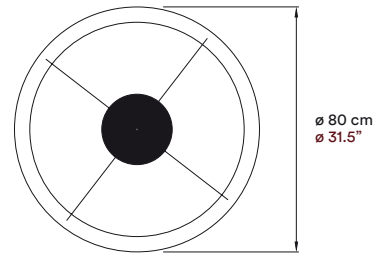
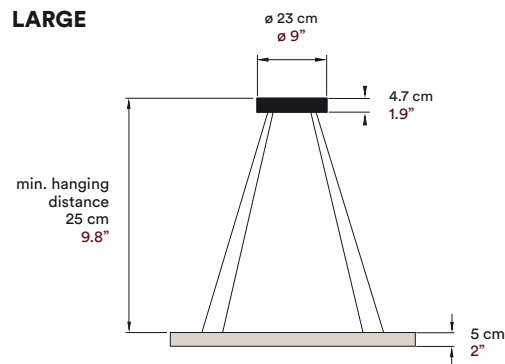

MATERIALS & COMPONENTS

Wood Veneer Shade

Bottom White Acrylic Diffuser

Top Black Metallic Ring

Metal Canopy

2 Black Steel Cables

2,5 m drop 8 ft drop

2 Black Electrified Cables

2,5 m drop 8 ft drop

LIGHT SOURCE

120 - 277V

Dimmable Integrated LED

Class I

120 - 277V

Dimmable Integrated LED



FINISHES

WOOD VENEER COLOURS

- 20 Ivory White
- 21 Natural Cherry
- 22 Natural Beech
- 24 Yellow
- 29 Grey
- 25 Orange
- 33 Pale Rose
- 26 Red
- 34 Sea Blue
- 28 Blue

METAL CANOPY COLOUR

- BK-Matte Black



Go to web



● OH!LINE - SUSPENSION
20 Ivory White Wood Veneer.

Piknik

Cordless Table

Designed by:
Macalula

The portable Piknik lamp is happy both indoors and outdoors. Piknik is handsome, adaptable and smart. Its cleverly designed tubular wood veneer lampshade hangs freely, while its rechargeable battery will keep going for up to eight hours. Befitting a modern lifestyle, Piknik also features touch sensor dimming. All charged up and ready to go, simply take the Piknik's handy handle and happily untethered, it will feel at ease in your gracious company.



P
I
K
N
I
K



• PIKNIK - CORDLESS | 24 Yellow Wood Veneer.

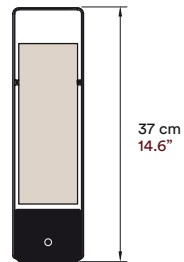

MATERIALS & COMPONENTS

Wood Veneer Shade

Interior Acrylic Diffuser

Metal Base & Handle

Rechargeable Battery

8 Hours Autonomy at 90% Power

IN Charge only, charging cable supplied
USB type C

On / Off Dimming

LIGHT SOURCE

Dimmable Integrated LED

Class III

Dimmable Integrated LED

FINISHES

WOOD VENEER COLOURS

- | | |
|-------------------|------------------|
| 20 Ivory White | 22 Natural Beech |
| 21 Natural Cherry | 29 Grey |
| 24 Yellow | 33 Pale Rose |
| 25 Orange | 34 Sea Blue |
| 26 Red | 28 Blue |

METAL COLOURS

- BK-Matte Black

AWARDS



Germany



Germany



Go to web



● PIKNIK - CORDLESS
21 Natural Cherry Wood Veneer.

POD &

Designed by: | Medium
Burkhard Dämmer | Suspension

Kin to the Poppy pendant, Pod is a vertically elongated and ellipse-like orbit of light whose body is made up of a repeated series of wood veneer strips. Different from the Poppy, a small gap between each strip on the Pod allows just a peek at the light within.

The Pod is appreciably unostentatious, having a fresh manner that smiles and illuminates its surroundings with an altruistic sense of cool. It is a pendant that works well discretely or as part of a striking cluster of Pod and Poppy lights.

POPPY

Small & Medium
Suspension

Kin to the Pod pendant, the slightly squat and spherical Poppy lamp is made up of a repeated series of wood veneer strips. Different from the Pod, a larger gap between each strip on the Poppy emits light with a greater luminosity, its mature form sparkling in full bloom.

Compared to the Pod pendant, Poppy is like the mature older sibling, with a fully developed form that lends weight to its mellow disposition. Both the Poppy and Pod lamps work well in unison, able to form impressive cloud-like clusters.



● POD & POPPY - SUSPENSION | 24 Yellow Wood Veneer.



POD - MEDIUM SUSPENSION | 34 Sea Blue

POPPY & POD

SUSPENSION

BURKHARD DÄMMER

POPPY SMALL

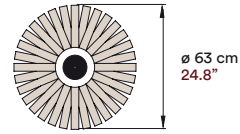
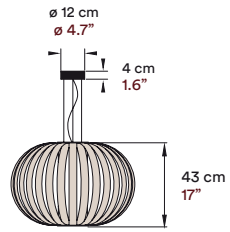

POPPY MEDIUM

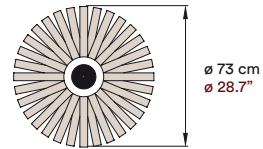
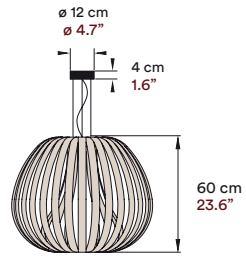

POD MEDIUM

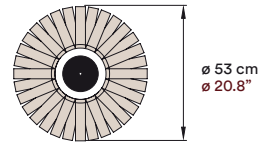
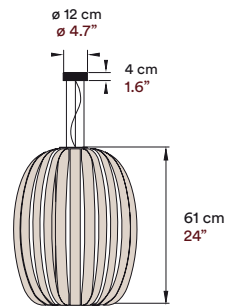

MATERIALS & COMPONENTS

Wood Veneer Shade

Metal Canopy

3 Stainless Steel Cables
2,5 m drop 8 ft drop

Transparent Electrical Cable
2,5 m drop 8 ft drop

LIGHT SOURCE

220 - 250V
Bulb E27

Class I

120V
Bulb E26



FINISHES

WOOD VENEER COLOURS

- 20 Ivory White
- 21 Natural Cherry
- 22 Natural Beech
- 24 Yellow
- 29 Grey
- 25 Orange
- 33 Pale Rose
- 26 Red
- 34 Sea Blue
- 28 Blue

METAL CANOPY COLOUR

- NI-Nikel

POPPY



Go to web

POD



Go to web



Interior Design: Materia Singular.

● **POPPY - SMALL SUSPENSION**
20 Ivory White Wood Veneer.

RAINDROP

Raindrop

Small & Medium
Suspension

Designed by:
Javier Herrero Studio

Visualise the simple beauty of a stationary raindrop, a small and glistening droplet that instead of falling, remains in a state of suspended animation. While Tina couldn't stand the rain against her window, the Raindrop pendant is a welcome sight.

Javier Herrero imagined and designed the Raindrop pendant, its suspended shade made using strips of wood veneer that contain a glowing ball. Available in small and medium sizes, the Raindrop's form is playful and poised. It is a light that will hang gracefully by itself and is especially pleasing and engaging when arranged in a group formation.

● RAINDROP - MEDIUM SUSPENSION | 20 Ivory White Wood Veneer.



RAINDROP

SUSPENSION

JAVIER HERRERO STUDIO

SMALL

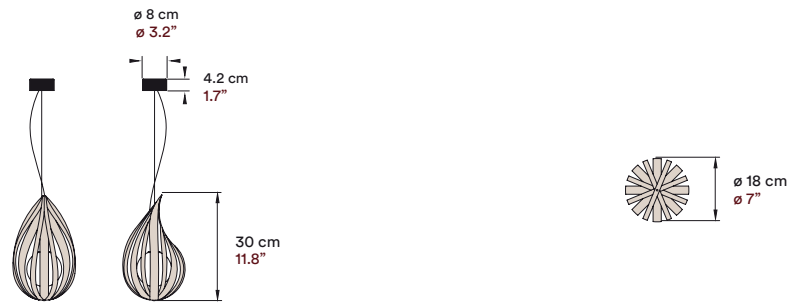

MEDIUM



MATERIALS & COMPONENTS

Wood Veneer Shade

Frosted Glass Ball

Metal Canopy

Transparent Electrical Cable
2,5 m drop 8 ft drop

Stainless Steel Cable
2,5 m drop 8 ft drop

LIGHT SOURCE

220 - 250V
Bulb G9

Class I

120V
Bulb G9



FINISHES

RECOMMENDED WOOD VENEER COLOURS

- 20 Ivory White
- 29 Grey
- 21 Natural Cherry
- 33 Pale Rose
- 22 Natural Beech
- 34 Sea Blue
- 28 Blue

METAL CANOPY COLOUR

- NI-Nikel



Go to web



● **RAINDROP**
SMALL SUSPENSION
21 Natural Cherry Wood Veneer.



● **RAINDROP**
MEDIUM SUSPENSION
21 Natural Cherry Wood Veneer.

SPIRO

Spiro

Medium & Large
Suspension

Designed by:
Remedios Simón

Op art (optical art) developed in the 1960s as an artistic style that used geometric shapes to generate optical illusions. With a nod to the genre, designer Remedios Simón created Spiro, a charismatic pendant whose frame contains a mass of irregular wood veneer spirals.

Available in three outer shell options (cherrywood, acrylic white or black), Spiro is an impressive light with an enchanting aura. Similar to op art, Spiro plays with the physiology and psychology of human perception, its charm utterly irresistible.

● SPIRO - LARGE SUSPENSION

Matte White Outer Shell & 22 Natural Beech Wood Veneer.



MSK Koch Center Hospital, NY, USA. Photography: Chris Cooper.



MEDIUM

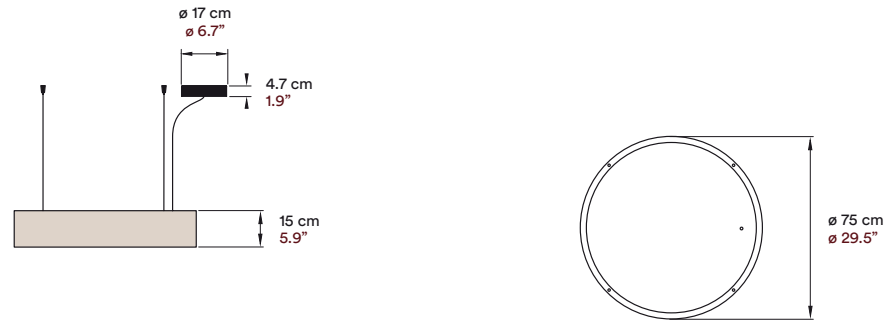

MATERIALS & COMPONENTS

Opaque Wood or Acrylic Outer Shell

Wood Veneer Spirals

Top & Bottom Diffuser

Metal Canopy

4 Stainless Steel Cables

2,5 m drop 8 ft drop

Electrical Cable

2,5 m drop 8 ft drop

LIGHT SOURCE

120 - 277V
Dimmable Integrated LED

Class I

120 - 277V
Dimmable Integrated LED

AWARDS

HD Las Vegas. Product Design Competition. USA

FINISHES

WOOD SHELL

21 Natural Cherry

ACRYLIC SHELL

Black

White

WOOD VENEER SPIRALS WITH WOOD SHELL

21 Natural Cherry

WOOD VENEER SPIRALS WITH ACRYLIC SHELL

20 Ivory White

26 Red

21 Natural Cherry

28 Blue

22 Natural Beech

29 Grey

24 Yellow

33 Pale Rose

25 Orange

34 Sea Blue

METAL CANOPY COLOURS

BK-Matte Black

WH-Matte White



Go to web



Photography: Emilio Lekuona

● SPIRO - MEDIUM SUSPENSION
Matte White Outer Shell & 28 Blue Wood Veneer.

STITCHES

Stitches

Bamako
Tombuctú

Designed by:
Burojet

Created by Egbert-Jan Lam of Netherlands-based Burojet Design Studio, Stitches is a family of two well-hemmed pendants: Tombuctú and Bamako. Each light is named after a city or town in Mali, West Africa. Mali has a long history as a producer of embroidery; its many skilled artisans found throughout Tombuctú and Bamako are adept at needlework.

The Stitches pendants impart an appealing bohemian air, their warm wood veneer panels embroidered with peeping threads of light. Crafted with passion and precision, Tombuctú and Bamako hint at the simple beauty found in Malian embroidery.

- **STITCHES BAMAKO - SUSPENSION**
24 Yellow Wood Veneer.



STITCHES

SUSPENSION

BUROJET

BAMAÑO



TOMBUCTÚ

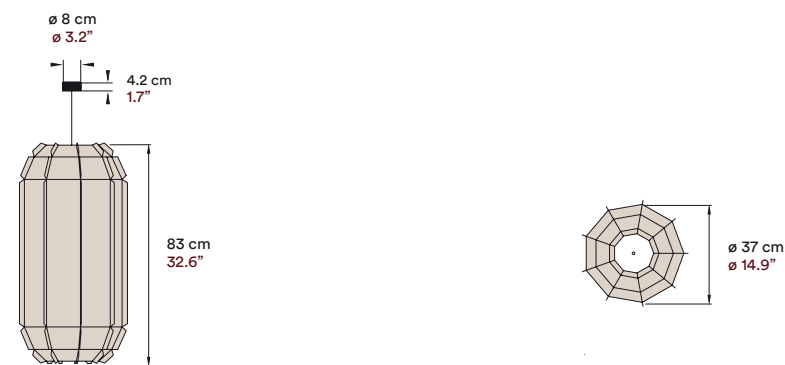

MATERIALS & COMPONENTS

Wood Veneer Shade

Metal Canopy

Transparent Electrical Cable
2,5 m drop 8 ft drop

FINISHES

RECOMMENDED WOOD VENEER COLOURS

- 20 Ivory White
- 33 Pale Rose
- 24 Yellow
- 34 Sea Blue
- 29 Grey

METAL CANOPY COLOUR

- NI-Nikel

LIGHT SOURCE

220 - 250V Class I
Bulb E27

120V
Bulb E26

AWARDS



Chicago

Germany



Go to web



Go to web



Photography: Santiago Relanzón

● STITCHES TOMBUCTÚ - SUSPENSION
20 Ivory White Wood Veneer.

S

W

R

Swirl

Small & Large
Suspension

Designed by:
Ray Power

Swirl excites the eye with its eddying and whirling folds, their twisting twirl a sensuous feat. Designed by Ray Power, Swirl is an accomplished pendant, its form thoughtfully considered and sculptured. Power's designs are typically based on geometry and his predilection for creating three-dimensional forms from flat materials (wood veneer). Swirl is no exception, its precise contours brought to life in stereo.

With a soulful character and presence, the Swirl lamp will vibrate well with any interior. When a light is striking from every angle, one might expect more than a hint of conceit. And yet Swirl is wholly modest, its beauty inspiring and uplifting.

The Swirl pendant was accorded a Special Mention by the German Design Council.

- **SWIRL - SMALL SUSPENSION**
20 Ivory White Wood Veneer.



Photography: Davide Pellegrini.

SWIRL

SUSPENSION

RAY POWER

SMALL

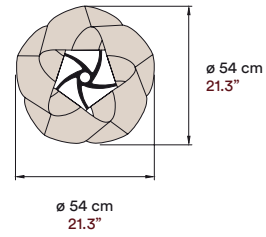
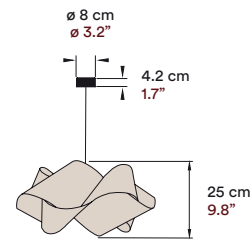

LARGE

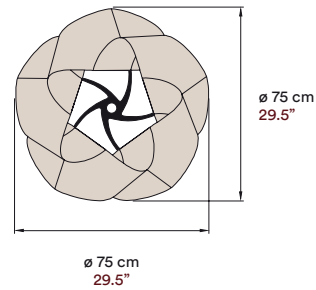
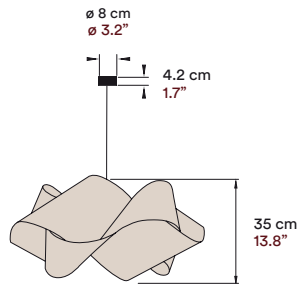

MATERIALS & COMPONENTS

Wood Veneer Shade

Metal Tripod & Canopy

Electrical Cable
2,5 m drop 8 ft drop

LIGHT SOURCE

220 - 250V Class I
Bulb E27

120V
Bulb E26

FINISHES

WOOD VENEER COLOURS

- 20 Ivory White
- 21 Natural Cherry
- 22 Natural Beech
- 24 Yellow
- 29 Grey
- 25 Orange
- 33 Pale Rose
- 26 Red
- 34 Sea Blue
- 28 Blue

METAL COLOURS

- BK-Matte Black
- NI-Nickel
- WH-Matte White

AWARDS



Chicago



Germany



Go to web

- **SWIRL - SMALL SUSPENSION**
26 Red Wood Veneer.

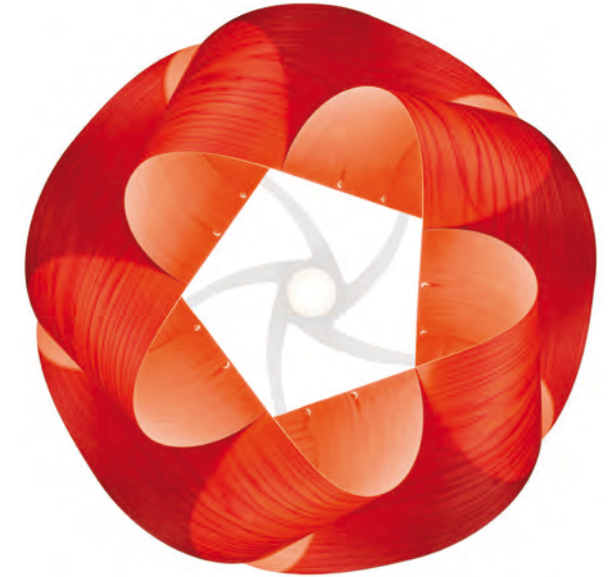

- **SWIRL - SMALL SUSPENSION**
20 Natural White Wood Veneer.

- **SWIRL - SMALL SUSPENSION**
22 Natural Beech Wood Veneer.



THESIS

Thesis

Floor
Table
Wall

Designed by:
Ramón Esteve Estudio

Thesis is a table, floor and wall lamp. It is a modern piece whose companionship is close and intimate, casting a warm glow as you toil through the night and by your side as you read or simply contemplate the day.

Designed by Ramón Esteve, the Thesis is well suited to quiet spaces: in a library, private study or cosy corner, its minimal form and clean lines are free from distraction. In creating Thesis, a modest metallic base holds a wood veneer shade in its three prongs. Each prong contains an LED that diffuses light downwards while casting a radiance that quietly highlights the natural timber veneer. In profile, it is authoritative and introspective, a quiet light with a smart, introverted personality.



Photography: Ángel Segura

● **THESIS - FLOOR**
20 White Wood Veneer & Matte Black Metal Base.



Photography: Angel Segura

● **THESIS - FLOOR & TABLE** | 20 White Wood Veneer & Ivory White Metal Base.

FLOOR

TABLE

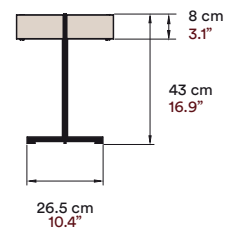
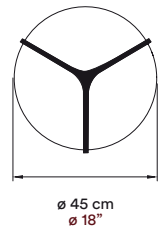
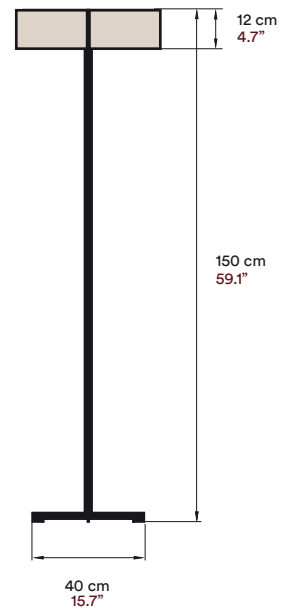

MATERIALS & COMPONENTS

Wood Veneer Shade

Metal Tripod, Stem & Base

Electrical Cable with Dimming Switch Transformer on Plug

FLOOR 185 cm 53"

TABLE 145 cm 57"

FINISHES

WOOD VENEER COLOURS

○ 20 Ivory White

METAL COLOURS

● BK-Matte Black

○ IV-Matte Ivory

LIGHT SOURCE

230V Dimmable Integrated LED



120V Dimmable Integrated LED



FLOOR



Go to web

TABLE



Go to web



● THESIS - TABLE
20 Ivory White Wood Veneer & Matte Black Metal Base.



Photography: Angel Segura

• THESIS - WALL | 20 Ivory White Wood Veneer & Matte Black Metal Structure.

SWING MECHANISM

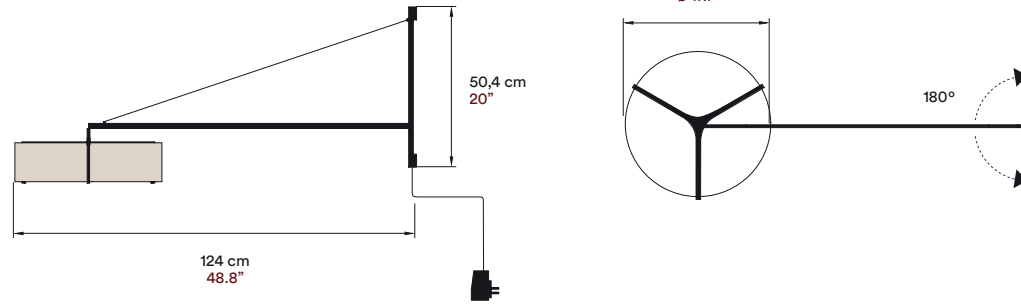

HARD WIRED

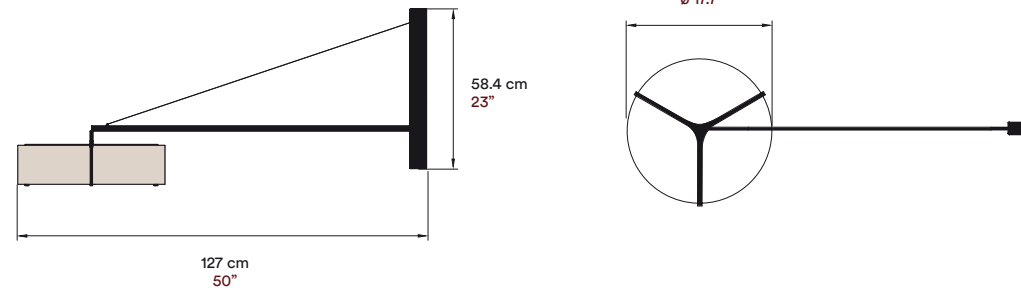

MATERIALS & COMPONENTS

Wood Veneer Shade

Metal Tripod & Structure

Pivoting Metal Arm with wall plug
Electrical Cable 250 cm 98,4"

Hard Wired with wall mounted driver enclosure

FINISHES

WOOD VENEER COLOURS

○ 20 Ivory White

METAL COLOURS

● BK-Matte Black ○ IV-Matte Ivory

LIGHT SOURCE

230V - Plug in version

Dimmable Integrated LED or

120-277V - Hard wired version

Dimmable Integrated LED

Class II

120V - Plug in version

Dimmable Integrated LED

120-277V - Hard wired version

Dimmable Integrated LED



Go to web



● THESIS - WALL

20 Ivory White Wood Veneer & Matte Black Metal Structure.



| **BIG SIZE** |
| **COLLECTION** |

CAMI DELABRO

Candelabro

Small & Large
Suspension

Designed by:
Mariví Calvo

Imagine a suspension light that embodies many of LZP's greatest hits. Candelabro describes a remarkably representational form that unites the finest collection of wood veneer pendants. The performers include such luminaries as Agatha and Mikado, Raindrop and Totem.

Hovering amid the lights are a number of golden birds, each one enjoying a magical world of wonder. Together, these birds and the various pendants stage a thrilling opus in light, a majestic piece that will give the viewer pleasure every time.

• CANDELABRO - SMALL SUSPENSION
20 Ivory White Wood Veneer.



Interior Design: Materia Singular.

SMALL

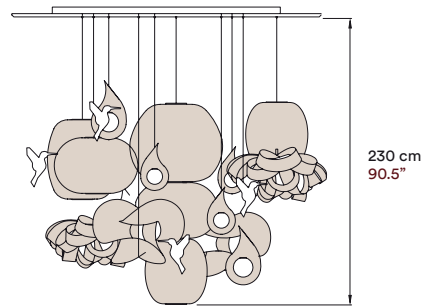
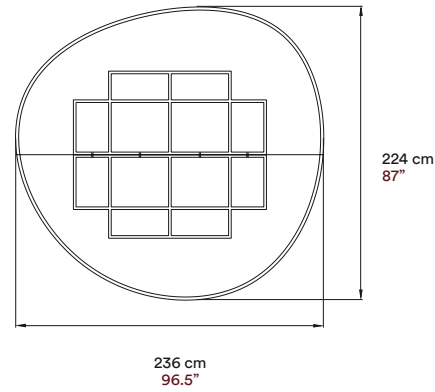
230 cm
90.5"224 cm
87"236 cm
96.5"

LARGE

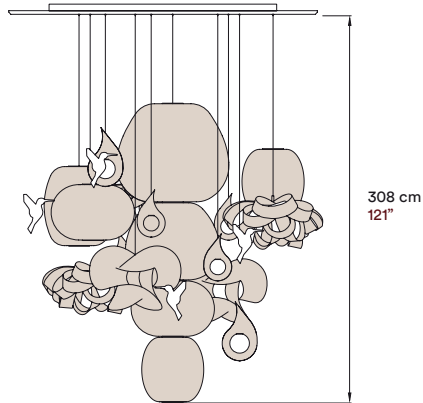
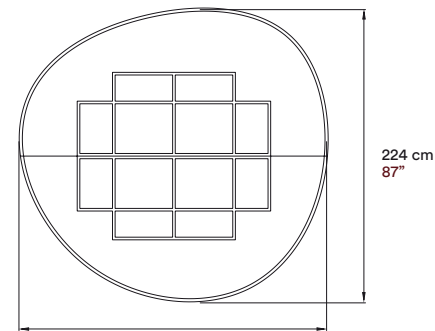
308 cm
121"224 cm
87"236 cm
96.5"

MATERIALS & COMPONENTS

15 Wood Veneer Shades

Matte White Lacquered Wood Canopy

6 Ceramic Birds* in Gold or White Glaze

* Can be bought separately

FINISHES

WOOD VENEER COLOURS

○ 20 Ivory White ● 22 Natural Beech

LIGHT SOURCE

3 Independent Dimmable Circuits.
Central Shade, Peripheral Shades & Spotlights.

220 - 250V

Class I CE

120V

UL US



Go to web



● CANDELABRO
LARGE SUSPENSION
20 Ivory White Wood Veneer.



Photography: Richard Goncalves.

- CANDELABRO - CUSTOM SUSPENSION
21 Natural Cherry Wood Veneer.

DAN DE LION



Dandelion

Designed by:
Burkhard Dämmer

Suspension

• DANDELION - SUSPENSION
24 Yellow Wood Veneer.

Bearing a resemblance to its flowering namesake, this lamp is a radiant composite of many single florets. Independent and distinct, each funnel-shaped floret appears to shine alone, yet en masse they create the Dandelion's sparkle.

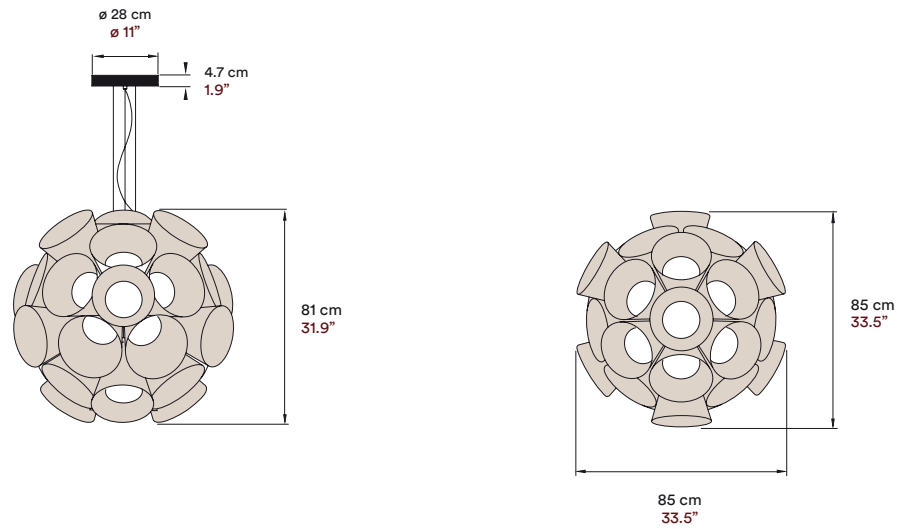

MATERIALS & COMPONENTS

Wood Veneer Shade

Acrylic Diffusers

Metal Canopy

3 Stainless Steel Cables

2,5 m drop 8 ft drop

Transparent Electrical Cable

2,5 m drop 8 ft drop

LIGHT SOURCE

120 - 277V

Dimmable Integrated LED

Class I

120 - 277V

Dimmable Integrated LED

FINISHES

WOOD VENEER COLOURS

- 20 Ivory White
- 21 Natural Cherry
- 22 Natural Beech
- 24 Yellow
- 29 Grey
- 25 Orange
- 33 Pale Rose
- 26 Red
- 34 Sea Blue
- 28 Blue

METAL CANOPY COLOUR

- NI-Nikel

AWARDS



Chicago



Germany



Brussels



Go to web



Photography: Qualiti

• DANDELION - SUSPENSION
21 Natural Cherry Wood Veneer.

LINK CHAIN

Link Chain

Small, Medium &
Large Suspension

Designed by:
Ray Power &
Mariví Calvo

The Link Chain is a pendant that immediately draws the eye. Resplendent in its precise arrangement, the Link Chain is especially heroic: bold and venturesome, prodigious and grand. Adding an element of drama to its surroundings, the Link Chain decorates, illuminates and captivates.

The Link Chain was conceived by Mariví Calvo and Ray Power. Using the Link Modular suspension lamp, the Link Chain is constructed with three, four or six modules. The effect is quite remarkable: the billowy, cloud-like Link modules are fastened together, metamorphosing into a heroic tower of light.

● LINK CHAIN - SMALL SUSPENSION
20 Natural White Wood Veneer.



LINK CHAIN

SUSPENSION

RAY POWER & MARIVÍ CALVO

SMALL

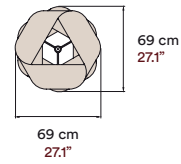
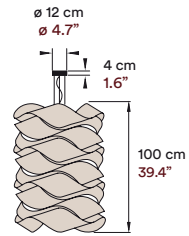

MEDIUM

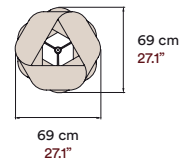
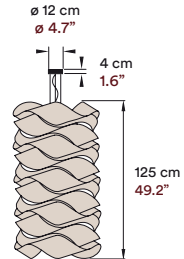

LARGE

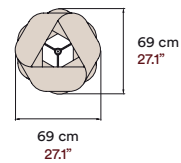
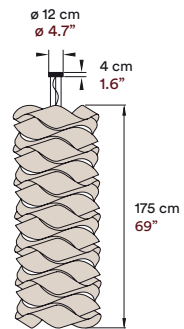

MATERIALS & COMPONENTS

Wood Veneer Shade

White Metal Tripod

Metal Canopy

3 Stainless Steel Cables

2,5 m drop 8 ft drop

Transparent Electrical Cable

2,5 m drop 8 ft drop

LIGHT SOURCE

220 - 250V

3, 4 or 6 Bulbs E27

Class I

120V

3, 4 or 6 Bulbs E26



FINISHES

RECOMMENDED WOOD VENEER COLOURS

20 Ivory White

21 Natural Cherry

22 Natural Beech

METAL CANOPY COLOUR

NI-Nikel



Go to web



● LINK CHAIN LARGE - SUSPENSION
20 Ivory White Wood Veneer.

● LINK CHAIN CUSTOM - SUSPENSION
20 Ivory White Wood Veneer.



As the Link Chain is a modular system, it allows for different lengths and combination of Link shade modules upon request.

SUNS

Suns

Small, Medium &
Large Suspension

Designed by:
Mikiya Kobayashi

Suns is a decorative wood veneer panel that acts to diffuse light and break sound. Designed by Tokyo & Valencia-based Mikiya Kobayashi, Suns panels are available in three sizes: small, medium, and large.

Japan is affectionately known as the 'land of the rising sun', and in Suns we find a handmade,

circular wood panel that is characterised by a quiet and respectful beauty—an inherent Japanese quality. Without light or electrification, the Suns panel is made up of wood veneer and a metal canopy. Designed to hang at an angle, Suns is striking and stellar when placed in a cluster formation.



Photography: Santiago Belanzón

● SUNS - DECORATIVE PANEL
20 Ivory White Wood Veneer.

SUNS

DECORATIVE PANEL

MIKIYA KOBAYASHI

SMALL

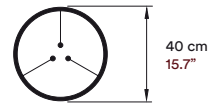
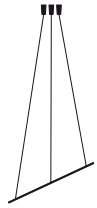

MEDIUM

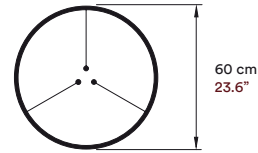
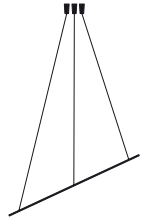

LARGE

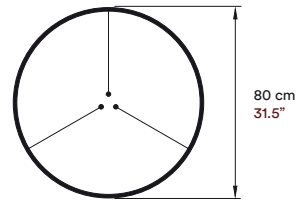
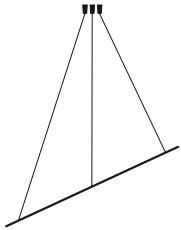

MATERIALS & COMPONENTS

Wood Veneer Panel

Metal Structure

3 Black Steel Cables
2,5 m drop 8 ft drop

THIS FIXTURE IS NOT ELECTRIFIED AND CONTAINS NO LIGHT SOURCE

Sun is a decorative circular panel that can be installed at different angles and that breaks up sound and interacts with light. The sun panel does not contain a light source.

FINISHES

WOOD VENEER COLOURS

○ 20 Ivory White

METAL COLOURS

● BK-Matte Black



Go to web



● SUNS - DECORATIVE PANEL
20 Ivory White Wood Veneer.





Photography: Santiago Relanzón

Totem

Totem is a veritable feast for the senses, a light whose proportions enliven a space with dramatic effect. Envisaged by designers Mariví Calvo and Burkhard Dämmer, Totem evolved from the clever amalgamation of Dämmer's Pod and Poppy pendants.

A sublime lighting structure, Totem has the emblematic air of a sacred object, a light whose shape and spirit are reflected in cultures worldwide. Available in three stacked variations, the Totem pendant diffuses warm light through the gaps in its wood veneer strips. As a physical entity, Totem's presence is impressive. Just as important, its spiritual quality is entirely unreserved.

- **TOTEM - SMALL & MEDIUM SUSPENSION**
20 Ivory White & 28 Blue Wood Veneer.

Totem 3 & Totem 4
Suspension

Designed by:
Burkhard Dämmer
& Mariví Calvo

T
O
T
E

M

SMALL - TOTEM 3



MEDIUM - TOTEM 4

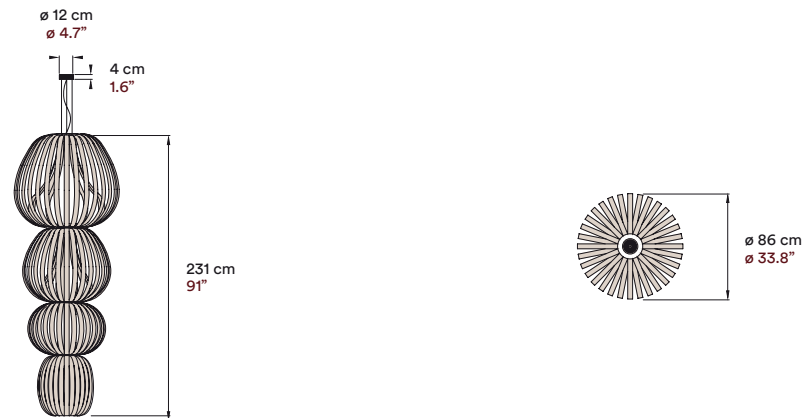

MATERIALS & COMPONENTS

3 or 4 Wood Veneer Shades

Metal Canopy

3 Stainless Steel Cables
2,5 m drop 8 ft drop

Transparent Electrical Cable
2,5 m drop 8 ft drop

LIGHT SOURCE

120 - 277V
Dimmable Integrated LED

Class I 

120 - 277V
Dimmable Integrated LED



FINISHES

RECOMMENDED WOOD VENEER COLOURS

-  20 Ivory White
-  21 Natural Cherry
-  22 Natural Beech

METAL CANOPY COLOUR

-  NI-Nikel

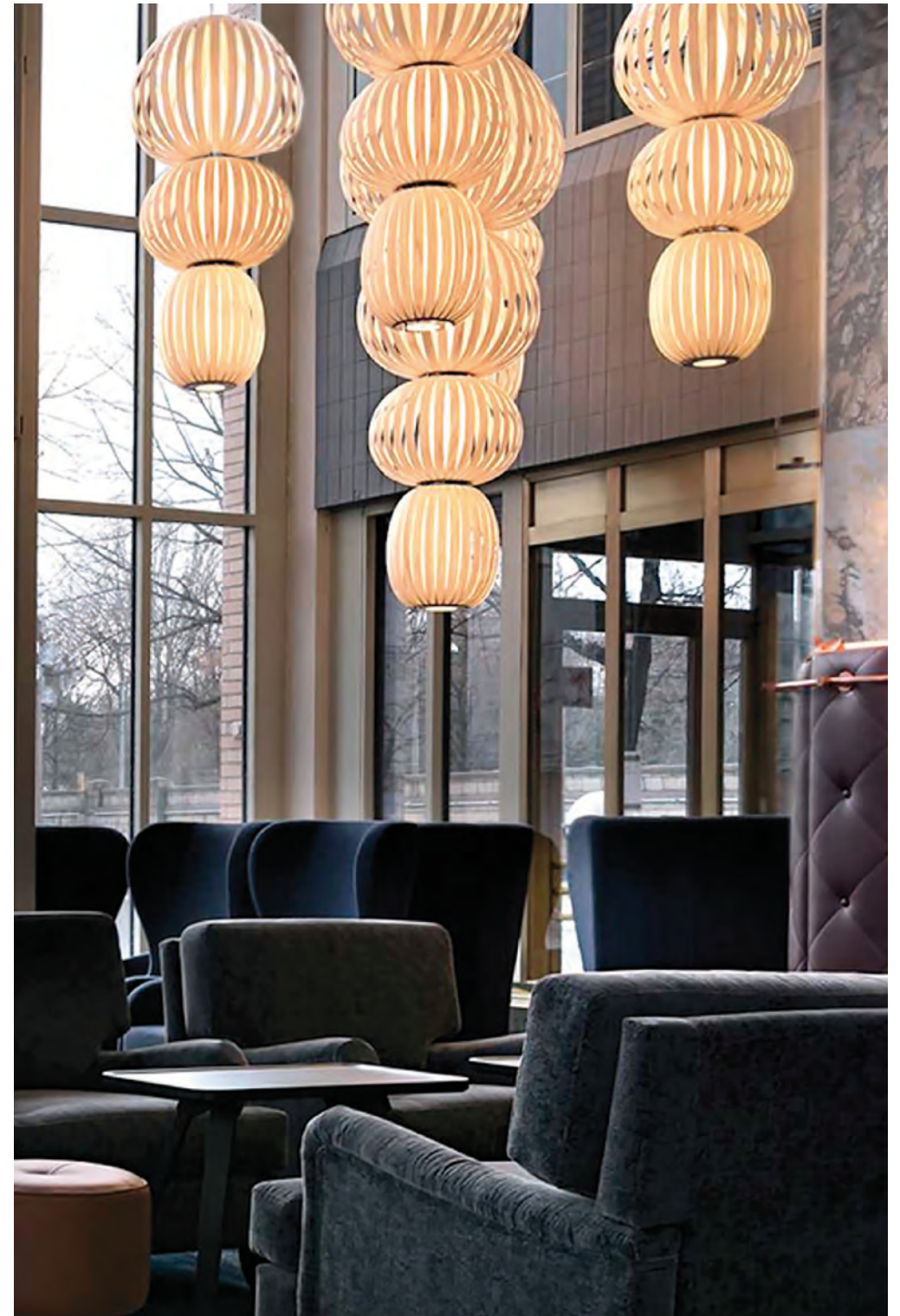

• TOTEM - MEDIUM & LARGE SUSPENSION | 20 Natural White Wood Veneer.





| LIFE SIZE |
COLLECTION |

KOI

Koi & Kogoi

Designed by:
Inocuo The sign & Marivi Calvo

Small & Large
Suspension

Part pendant, part sculpture, Koi is a dramatic and decorative light that appears as a surreal wood creature.

Koi has an ethereal beauty: engendering a considerable sense of wonderment, its animated form captivates the eye. Cutting an imposing figure, it offers the perfect lighting climax.

Its structure is made by the Master Artisan Manolo Martin, a specialist in the use of the vareta, light and malleable strips of wood that allow the construction of large extraordinarily light sculptures.



Photography: Santiago Relanzón

- **KOI - SUSPENSION**
20 Ivory Wood Veneer. Photo: 5.000k



• **KOI - SUSPENSION**
20 Ivory Wood Veneer. Photo: 2.700k

SMALL - KOGOI

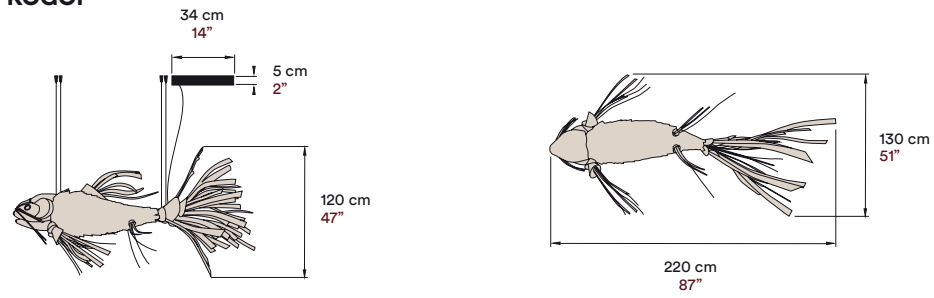

LARGE - KOI

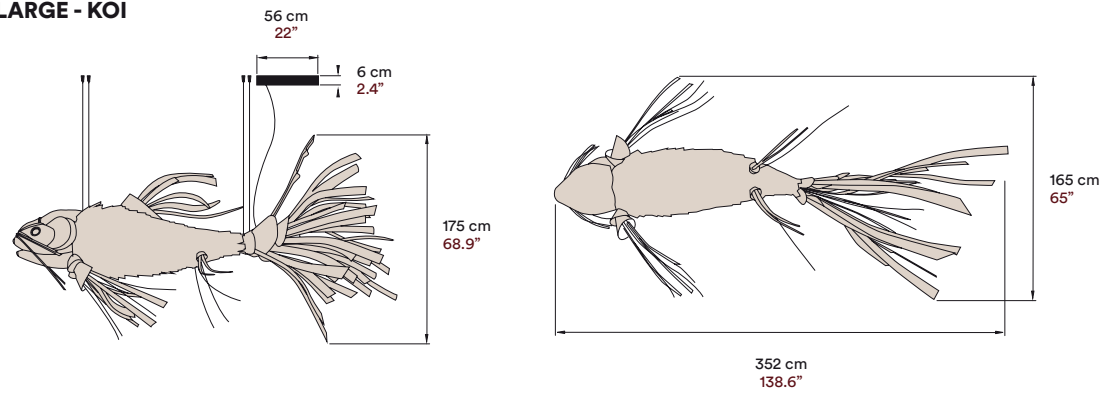

MATERIALS & COMPONENTS

Flame retarded Oak and Birch wood frame Structure

Wood Veneer interior Diffuser

Nickel Metal Canopy

4 Stainless Steel Cables
5 m drop 16.5 ft drop

Transparent Electrical Cable
5 m drop 16.5 ft drop

Each piece is numbered

FINISHES

WOOD VENEER COLOURS

- 23 Natural White
- 22 Natural Beech

LIGHT SOURCE

120 - 277V
Dimmable Integrated LED Class I CE

120 - 277V
Dimmable Integrated LED UL US

AWARDS



Chicago



Go to web



Photography: Santiago Relanzón

● KOI - SUSPENSION

20 Ivory White Wood Veneer. Photo: 5.000k

BIG BIRD

Small & Large
Suspension

Designed by:
Isidro Ferrer & LZF Lab

Big Bird & Birdy



Member of LZF's Life-Size family, Big Bird joins the happy adventures of Smelly Fant, Fish and Koi. Hovering vertically with fluttering wings, Big Bird has the agile appearance of a gentle hummingbird.

Created by the illustrator and designer Isidro Ferrer and built using a traditional craft technique called vareta, Big Bird is a masterly feat of wood craftsmanship. While light radiates from Big Bird's wooden plumage, a glass globe hangs from its beak, like a ball of glowing nectar.

With Big Bird, LZF is once again dreaming big, re-engineering the concept of what a lamp can be, in both shape and scale.

Its structure is made by the Master Artisan Manolo Martin, a specialist in the use of the vareta, light and malleable strips of wood that allow the construction of large extraordinarily light sculptures.

• BIG BIRD VERTICAL - SUSPENSION

Crafted Elm and Birchwood exterior - 20 Ivory White Interior Wood diffuser.



Photography: KlunderBie



LARGE

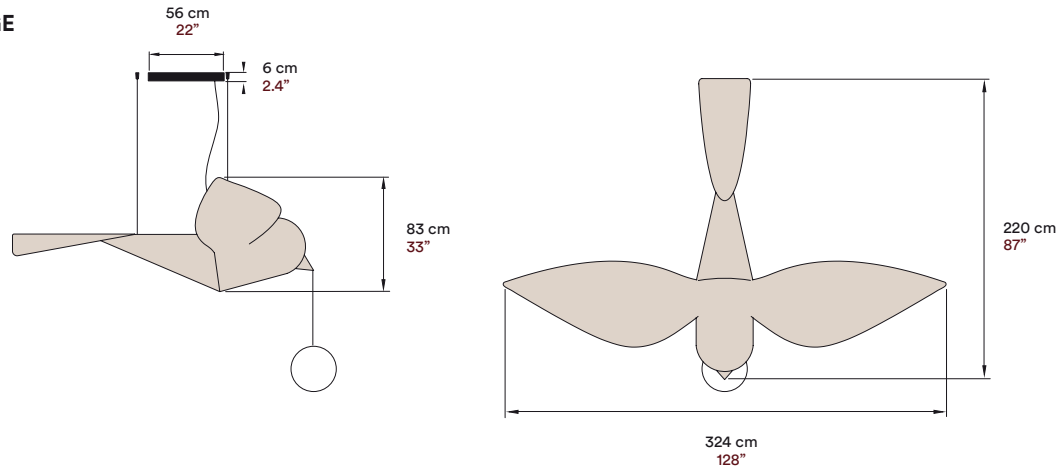

SMALL

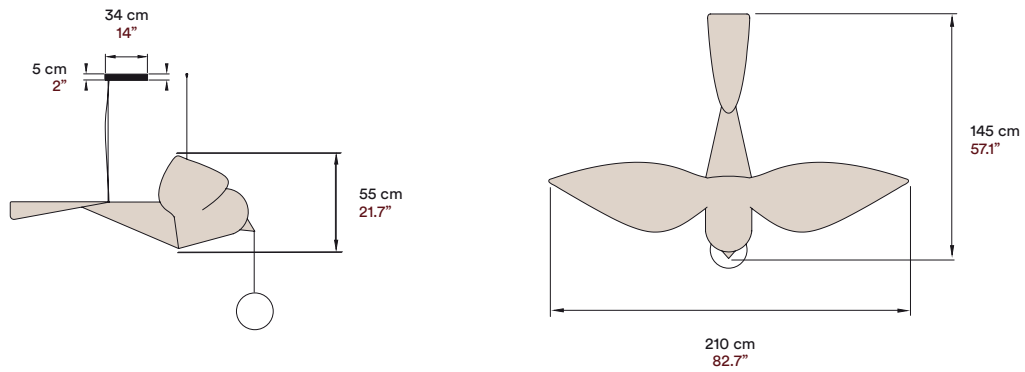

MATERIALS & COMPONENTS

Flame retarded Oak and Birch wood frame

Wood Veneer Diffuser

Frosted Glass Ball

Nickel Metal Canopy

3 Stainless Steel Cables

5 m drop 16.5 ft drop

Transparent Electrical Cable

5 m drop 16.5 ft drop

Each piece is numbered

FINISHES

INTERIOR WOOD VENEER COLOUR

● 23 Natural White

LIGHT SOURCE

120 - 277V
Dimmable Integrated LED &
230V
Bulb E27

Class I

120 - 277V
Dimmable Integrated LED &
120V
Bulb E26



Go to web

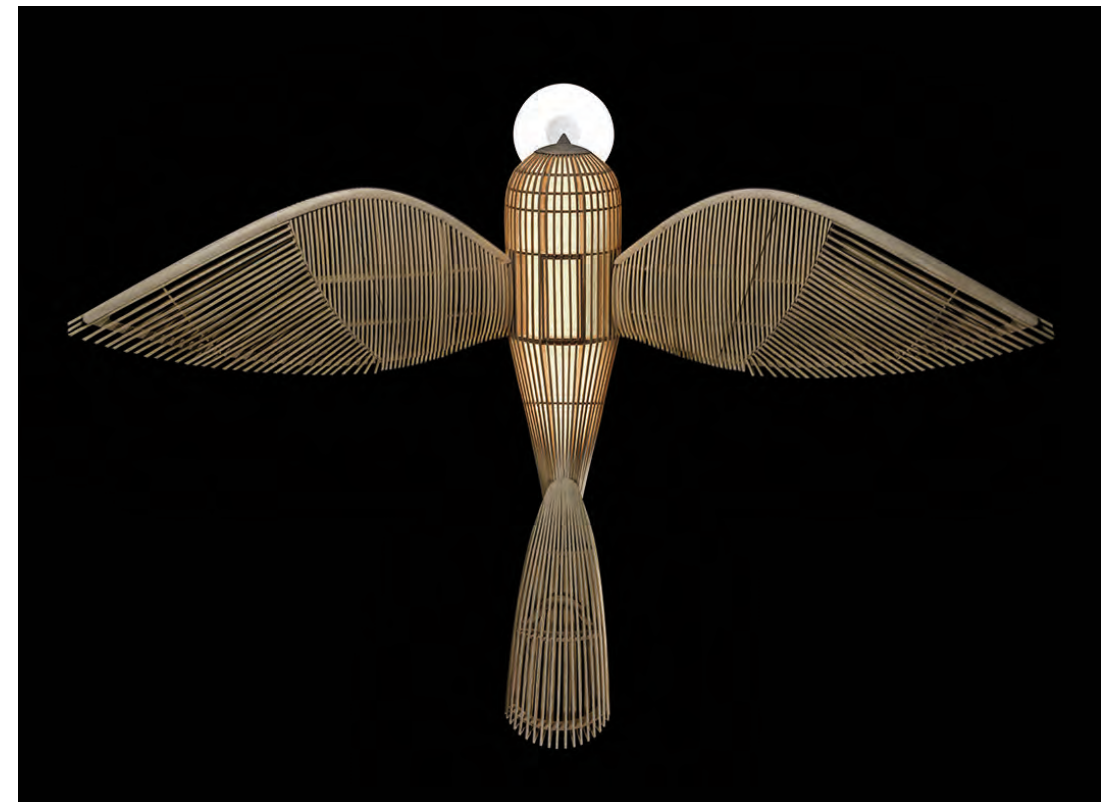
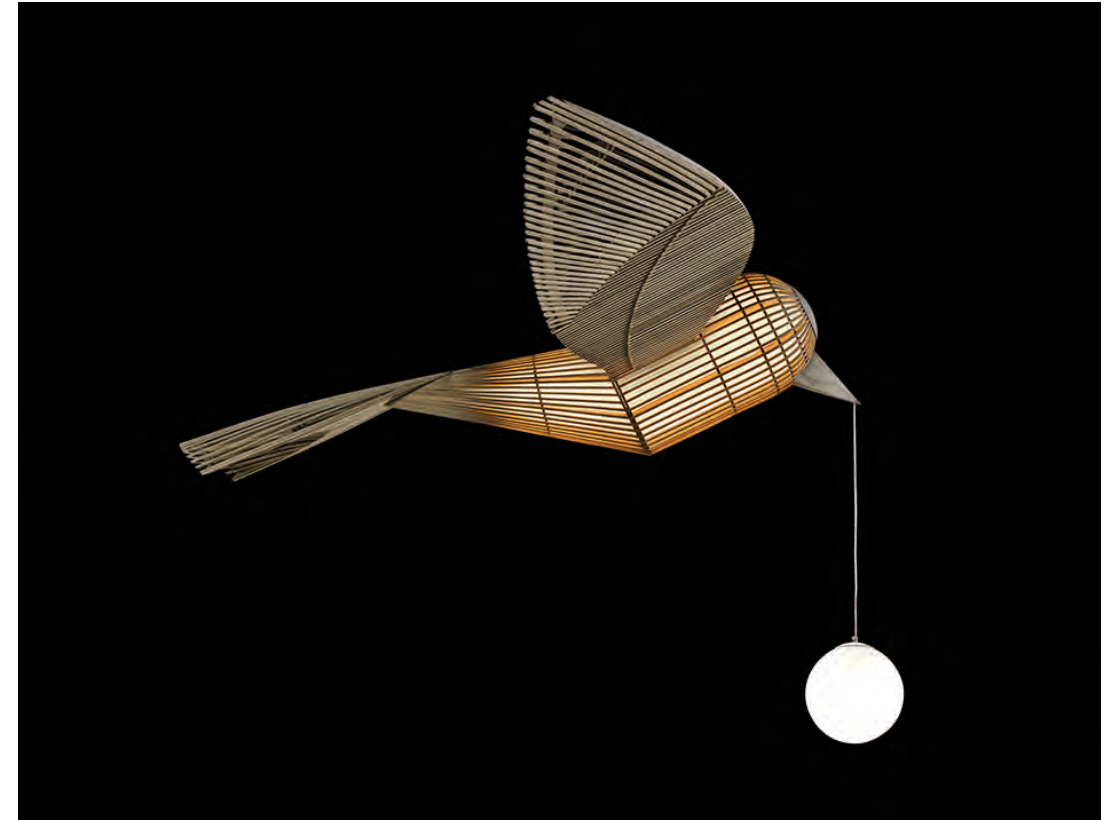



● BIRDY VERTICAL & HORIZONTAL - SUSPENSION |
Crafted Elm and Birchwood exterior - 20 Ivory White Interior Wood diffuser.

LARGE

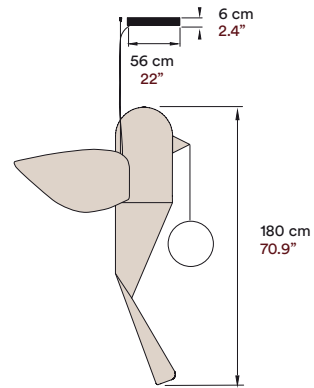
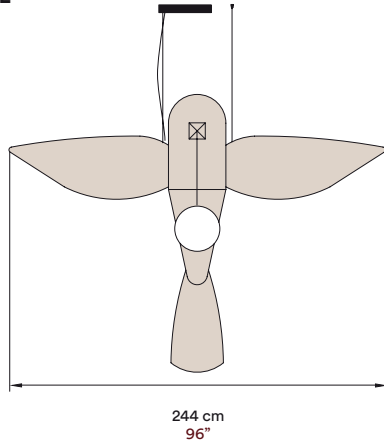

SMALL

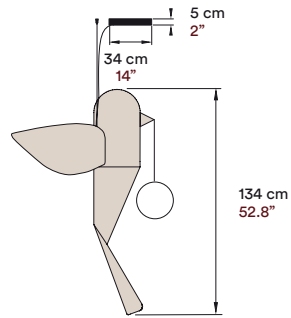
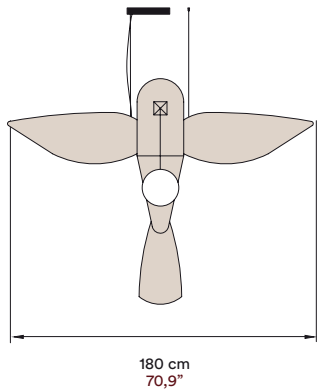

MATERIALS & COMPONENTS

Flame retarded Oak and Birch wood frame

Wood Veneer Diffuser

Frosted Glass Ball

Nickel Metal Canopy

2 Stainless Steel Cables
5 m drop 16.5 ft drop

Transparent Electrical Cable
5 m drop 16.5 ft drop

Each piece is numbered

FINISHES

INTERIOR WOOD VENEER COLOUR

● 23 Natural White

LIGHT SOURCE

120 - 277V
Dimmable Integrated LED &
230V
Bulb E27

Class I

120 - 277V
Dimmable Integrated LED &
120V
Bulb E26



Go to web



Photography: KlunderBie

● BIRDY SUSPENSION

Crafted Elm and Birchwood Exterior - 20 Ivory White Interior Wood Diffuser.

FISH

Floor

Designed by:
Isidro Ferrer & LZF Lab

The Walking Fish

Fish is modelled on one of the original pieces by Isidro Ferrer, a friendly fish with legs which has become one of the first large-scale light sculptures within the Funny Farm project. The carefully studied layout produces a captivating effect.

Its structure is made by the Master Artisan Manolo Martin, a specialist in the use of the vareta, light and malleable strips of wood that allow the construction of large extraordinarily light sculptures.

● **THE WALKING FISH - FLOOR**

Crafted Elm and Birchwood exterior, Interior Tulip Wood diffuser in 20 Ivory White.



Photography: KlunderBie

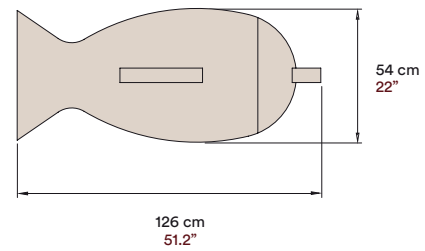
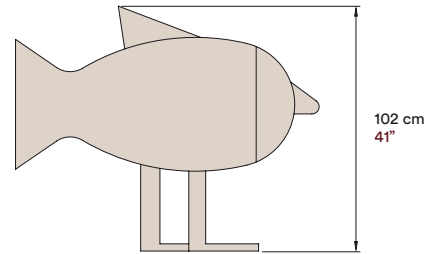

MATERIALS & COMPONENTS

Flame retarded Oak and Birch wood frame

Wood Veneer Diffuser

Red cloth cord Electrical Cable with On/Off Switch
200 cm 78,7"

Each piece is numbered

LIGHT SOURCE

Integrated LED Class II  

Integrated LED

FINISHES

INTERIOR WOOD VENEER COLOUR

 23 Natural White



Go to web

- **THE WALKING FISH- FLOOR .**
Crafted Elm and Birchwood exterior - 20 Ivory White Interior Wood diffuser.

SMELLY FANT

Smelly Fant

Floor

Designed by:
Isidro Ferrer & LZF Lab

Smelly Fant is the other Funny Farm animal we chose to convert into a light sculpture. Like all elephants, it has big ears, a trunk, even its own legs, and a body standing more than a meter and a half tall. To turn Isidro Ferrer's vision into a large-scale lamp, LZF has again drawn on the experience of the craftsman Manolo Martin.

Manolo Martin used the "vareta" technique, which consists of creating large, extraordinarily light sculptures out of malleable strips of wood to shape the three spheres which constitute the body and the head of Elephant. Its luminous heart, at the centre of the sculpture, is diffused through a natural wood veneer internal lining.

• SMELLY FANT - FLOOR

Crafted Elm and Birchwood Exterior.
20 Ivory White Interior Wood Diffuser.



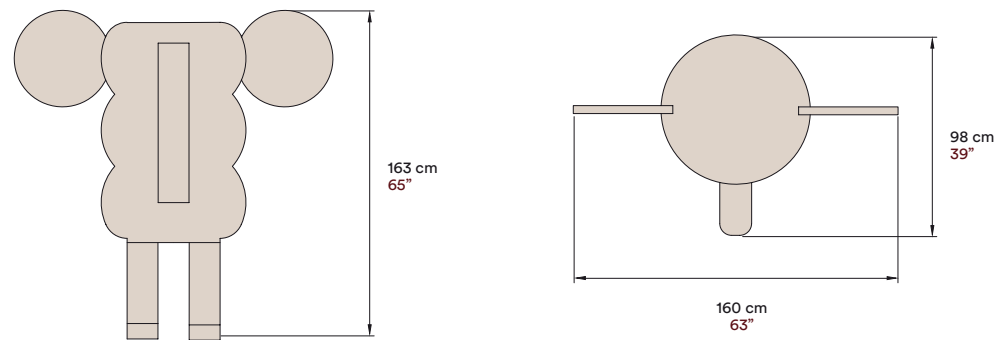

MATERIALS & COMPONENTS

Flame retarded Oak and Birch wood frame

Wood Veneer Diffuser

Red cloth cord Electrical Cable with On/Off Switch
200 cm 78,7"

Each piece is numbered

LIGHT SOURCE

Integrated LED

Class II

Integrated LED

FINISHES

INTERIOR WOOD VENEER COLOUR

23 Natural White

AWARDS



Chicago



Go to web



- **SMELLY FANT - FLOOR** | LZF "Dreams Book".
Crafted Elm and Birchwood exterior - 20 Ivory White
Interior Wood diffuser.



**SOURCE
LIGHT
TEMPERATURE**

Choose your light temperature carefully, wood veneer colour can change radically depending on the colour temperature you use.

Recommended temperature LED for coloured LZF shades:

20- Ivory White an 23-Natural White (3000k-6400k)

21-Cherry, 22-Beech, 28-Blue, 29-Grey and 34 Sea Blue (4000k)

24-Yelow, 25-Orange, 26-Red and 33 Pale Rose (2700k-4000k)

21 Natural
Cherry
Off



21 Natural
Cherry
4000k

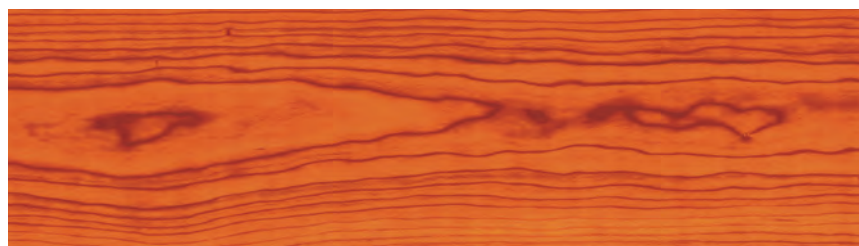

21 Natural
Cherry
3000k

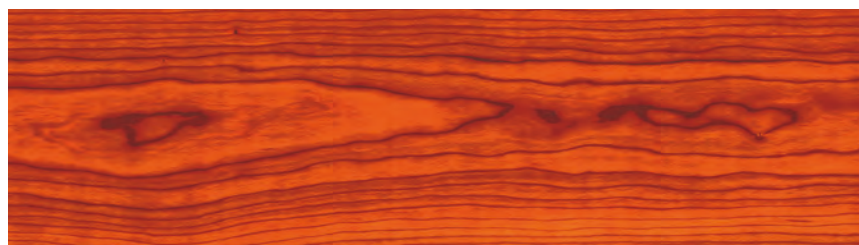

21 Natural
Cherry
2700k

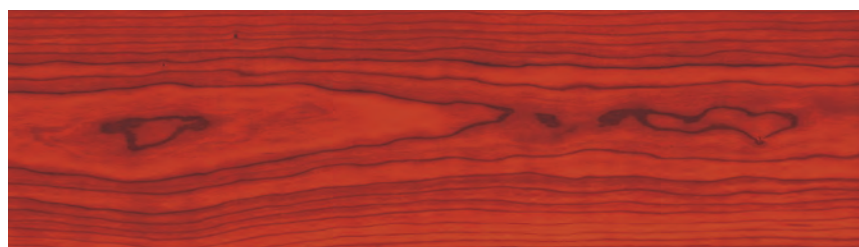

NATURAL TIMBER VENEER



The mark of responsible forestry



The dramatic effect of light passing through the wood veneer is the essence and hallmark of LZF. This important feature would not be possible without the application of our patented process in treating the raw natural veneer: the Timberlite® system.

This system, the result of LZF's research & development work, allows us to work with an extremely flexible yet very resistant veneer, which can take on many shapes without breaking. In addition to all our veneers being FSC certified, thanks to the treatment, the wood used to fabricate our lamps maintains its natural qualities, adopting different nuances and hues over time.

25.
Orange
Off



25.
Orange
On

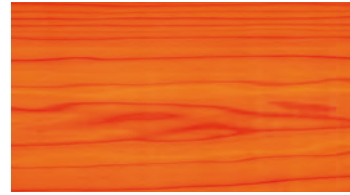

26.
Red
Off



26.
Red
On



28.
Blue
Off



28.
Blue
On

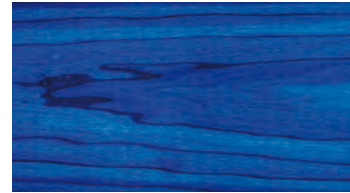

29.
Grey
Off



29.
Grey
On



33.
Pale Rose
Off



33.
Pale Rose
On



34.
Sea Blue
Off

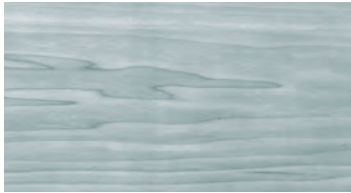

34.
Sea Blue
On

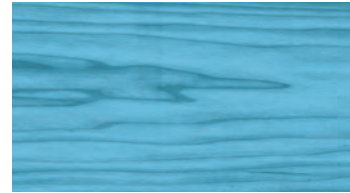

WOOD SHADE FINISHES

20.
Ivory White
Off



20.
Ivory White
On



21.
Natural
Cherry
Off



21.
Natural
Cherry
On

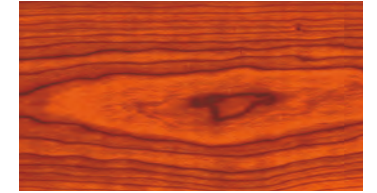

22.
Natural
Beech
Off



22.
Natural
Beech
On



23.
Natural White
Off



23.
Natural White
On



24.
Yellow
Off



24.
Yellow
On



Please only use these reproductions as a guide.
Use LZF wood swatches to see the spectacular real effect of the illuminated veneers.

BK
Matte Black

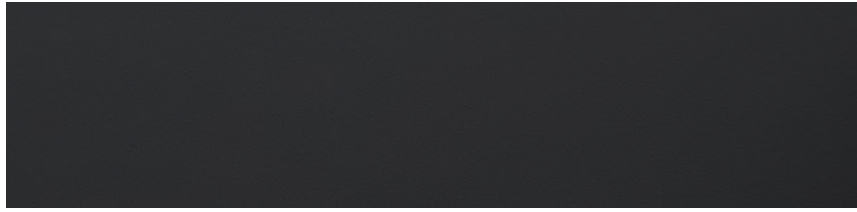

NI
Matte Nickel



GD
Gold



IV
Matte Ivory

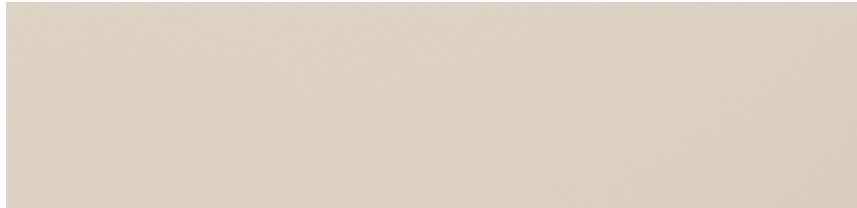

EG
Earl Grey
—
Osca collection



METAL FINISHES



For too many years things have been simply black and white, but life is made up of many shades and we have been wanting to create a more generous array of skin colours for our lights for quite sometime. This year we have wanted to offer you the choice of not just picking your shade colour but also the colour of the metallic finish that accompanies it. Matte tones or coloured reflections in satin nickel finishes provide a whole new range of choice when selecting your lamp.



CANDELA CORT

Candela



LUCAS MUÑOZ

Asap



BURKHARD DÄMMER

Dandelion
I-Club
I-Line
Oh!Line
Pod & Poppy
Totem



MARIVÍ CALVO

Candelabro
Gea
Guijarro
Koi
Oh!Line
Totem



BODO SPERLEIN

Oscá
Voliere



ELI GUTIÉRREZ

Omma



RAY POWER

Air
Escape
Kactos
Link
Lola
New Wave
Nut
Swirl
Tiny



ISIDRO FERRER

Big Bird
Smelly Fant
The Walking Fish



RAMÓN ESTEVE ESTUDIO

Black Note
Thesis

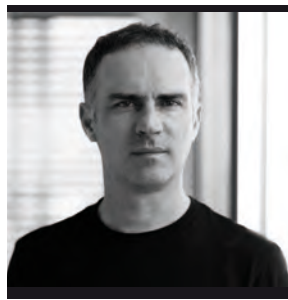

SUMMUMSTUDIO

Woodstraps



MIGUEL HERRANZ

MiniMikado
Orbit



BUROJET

Stitches



MUT DESIGN

Lens



YONOH CREATIVE STUDIO

Mini Chou



LUIS ESLAVA STUDIO

Agatha



MAYICE

Eris
Estela
Dune



JAVIER HERRERO STUDIO

Raindrop



GAZPACHO STUDIO

Maruja



REMEDIOS SIMÓN

Spiro



MIKIYA KOBAYASHI

Suns



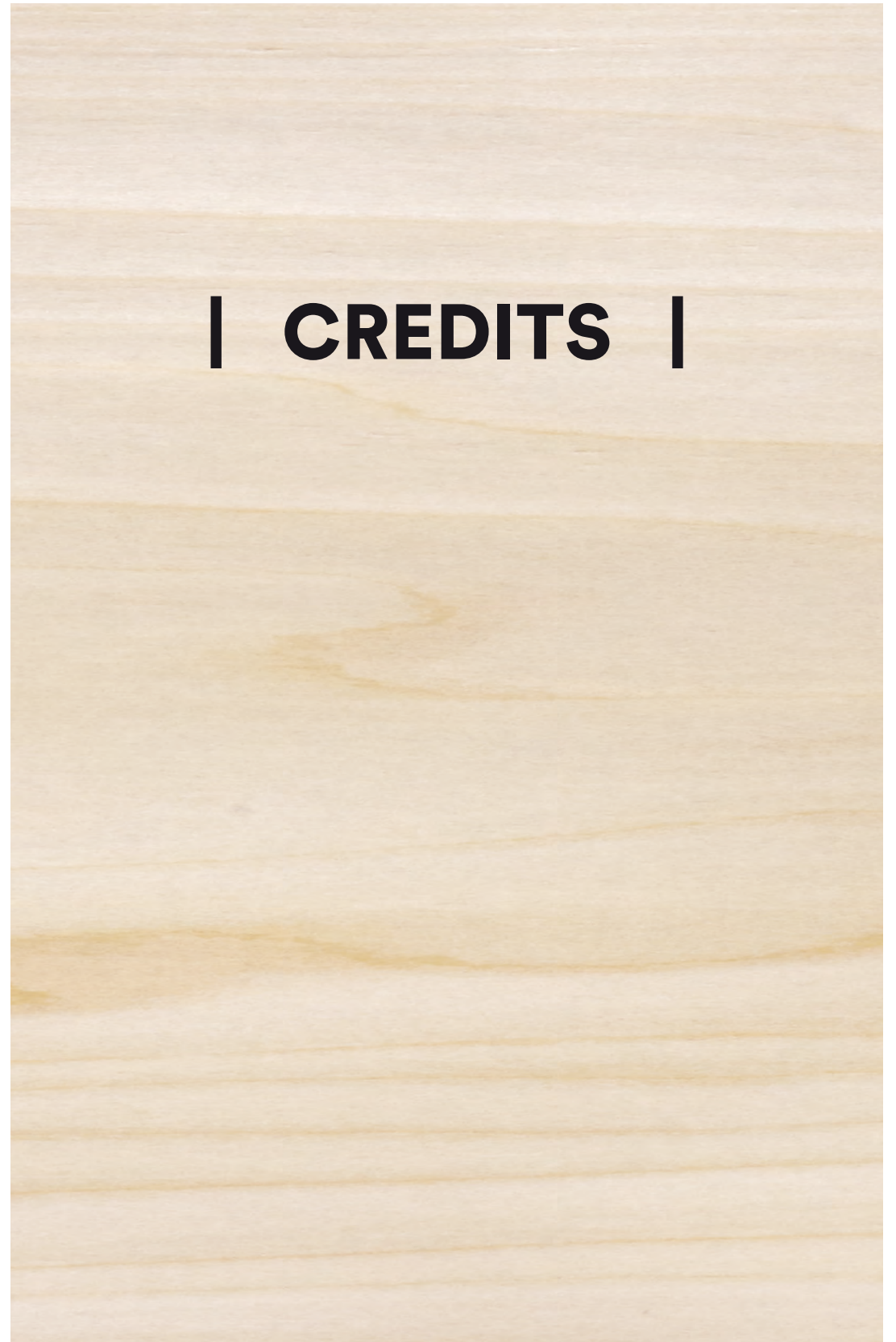



Project Director
Mariví Calvo

Photographers
Manu Toro
KlunderBie
Santiago Relanzón
Ángel Segura
Cualiti
Jara Varela
María Mira

Graphic Design
Lo Siento
Miriam Castellano

Writer
Gerard McGuickin



In the USA, LZF is exclusively distributed by:

IMPORT&ENT

IMPORT&ENT LLC. 2750 NW 84th Ave. Doral, FL 33122. T (404) 382-9023

lzf-lamps.com