

HARO
BY SPACE COPENHAGEN

Haro Wall Lamp

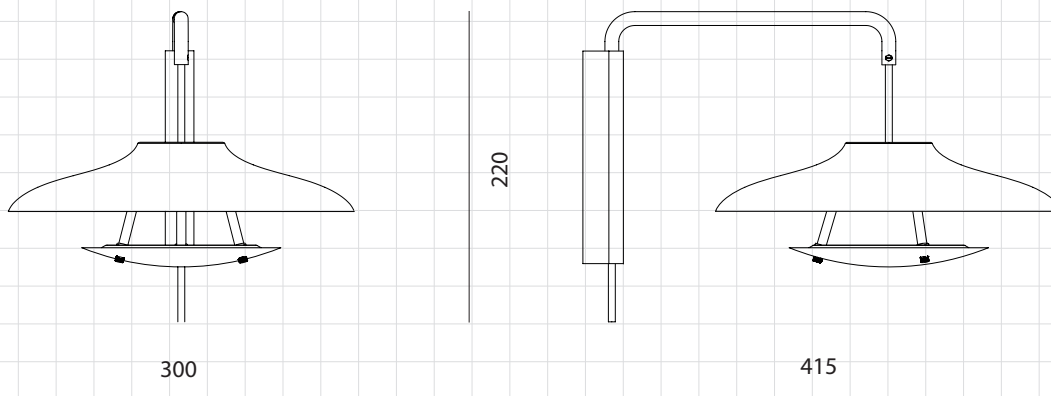

CODE

HA-W110

DIMENSIONS

W300 x D415 x H220mm

NET WEIGHT

1.60 kg

ENVIRONMENT

Indoor

MATERIALS

Powder coated steel shade, brass plated stainless steel structure

*Please refer to website or contact your local representative for complete material swatches.

SHIPPING

Package	Assembled		
Package Qty	1 pcs/box		
Packaging	Measurement (mm)	Volume (cbm)	Gross Weight (kg)
FCL/LCL/AIR	W485 x D360 x H210	0.04	2.59