

**HARO**  
**BY SPACE COPENHAGEN**

**Haro Table Lamp**

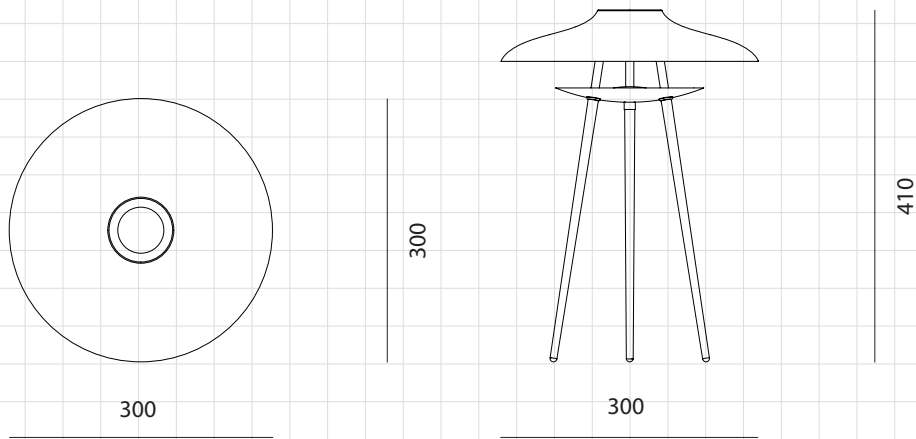

**CODE**  
**DIMENSIONS**

HA-TL110  
Ø300 x H410mm

**NET WEIGHT**  
**ENVIRONMENT**  
**MATERIALS**

1.55 kg  
Indoor  
Powder coated steel shade, brass plated stainless steel structure  
\*Please refer to website or contact your local representative for complete material swatches.

**SHIPPING**

<b>Package</b>	Assembled		
<b>Package Qty</b>	1 pcs/box		
<b>Packaging</b>	<b>Measurement (mm)</b>	<b>Volume (cbm)</b>	<b>Gross Weight (kg)</b>
<b>FCL/LCL/AIR</b>	W585 x D360 x H370	0.08	3.29