

**HARO**  
BY SPACE COPENHAGEN

**Haro Pendant**

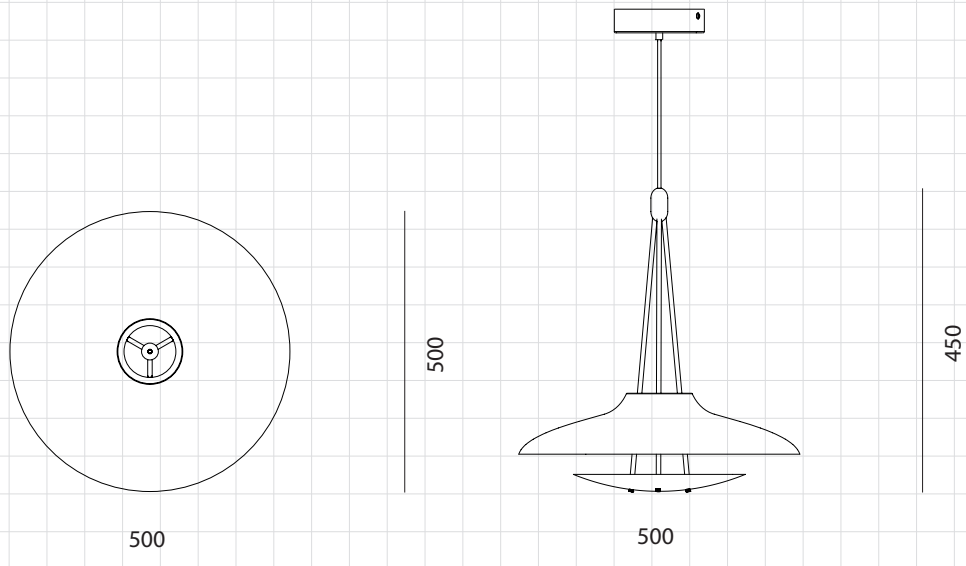

**CODE**  
**DIMENSIONS**

HA-P110  
Ø500 x H450mm

**NET WEIGHT**  
**ENVIRONMENT**  
**MATERIALS**

kg  
Indoor  
Powder coated steel shade, brass plated stainless steel structure  
\*Please refer to website or contact your local representative for complete material swatches.

**SHIPPING**

<b>Package</b>	Assembled		
<b>Package Qty</b>	1 pcs/box		
<b>Packaging</b>	<b>Measurement (mm)</b>	<b>Volume (cbm)</b>	<b>Gross Weight (kg)</b>
<b>FCL/LCL/AIR</b>	W580 x D580 x H575	0.19	