

nomon
JEWELRY FOR HOME

**Catalogue And Technical Index
2023**

We create jewelry for your home.
Creamos joyas para tu hogar.

Nomon Culture
P.6-P.7

Design & Tradition
P.8-P.9

Designers
P.10-P.11

Momentos Collection
P.12-P.63

Única Collection
P.64-P.85

Escultura Collection
P.86-101

Mixta Collection
P.102-109

Welcome Collection
P.110-P.113

Lighting Collection
P.114-P.125

Technical Information
P.126-P.134

Packaging
P.138-P.141

Environment
P.142-P.143



Culture JEWELRY FOR HOME

UNIQUE CONCEPT Nomon Home fuses passion for jewelry and furniture design, creating an innovative project, where the complementary furniture becomes the main role with elegance, style and sophistication.

NUESTRO CONCEPTO Nomon Home fusiona la pasión por la joyería y el diseño de mobiliario, creando un proyecto innovador, donde el mueble complementario se convierte en el protagonista de la elegancia, el estilo y la sofisticación.



NOMON STYLE Our style and personality at Nomon disregards fashion and trends, achieving a unique and renowned identity which persists over time.

ESTILO NOMON El estilo y la personalidad de Nomon es ajena a las modas y las tendencias consiguiendo una identidad reconocible estable y con recorrido.

Design TRADITION AND CRAFTSMANSHIP

NATURAL AND NOBLE We are faithful to noble materials, such as marble, natural walnut and brass; classics for our passion with craftsmanship, being able to combine romanticism and technology.

NATURALES Y NOBLES Somos fieles a los materiales nobles, el mármol, la madera y el metal y clásicos en nuestro amor por la artesanía, capaces de fusionar romanticismo y tecnología.





Designer ANDRÉS MARTÍNEZ

ANDRÉS MARTÍNEZ Born in Córdoba in a family with jewelry tradition; his creations are recognized with a true sense to noble materials and handcrafts, searching the true luxury, yet timeless and minimal.

ANDRÉS MARTÍNEZ Nacido en Córdoba en el seno de una familia de tradición joyera, sus creaciones se reconocen por la fidelidad a los materiales nobles y la artesanía en la búsqueda del auténtico lujo sereno, contenido y atemporal.



Designer STEFANO BIGI

STEFANO BIGI Stefano Bigi grew up between France and Italy. Out of this double culture, he acquired a taste for the chic and the beautiful. Studying at Art School, he specialized in design furniture, contributing a sculptural concept, fusion between art and object. Recognizable designs with great presence, artwork pieces worth of any gallery.

STEFANO BIGI Stefano Bigi es de origen francés y educado en Italia, lo que marca su estilo chic y elegante. Finalizados sus estudios en la Escuela de Arte se especializó en el diseño de mobiliario, aportando un concepto escultórico, fusión entre el arte y el objeto. Piezas reconocibles de gran presencia, obras de arte dignas de coleccionista.



Designer MERMELADA STUDIO
MIQUEL APARICI

MERMELADA STUDIO Mermelada is an industrial design studio founded by Laura Blasco, Juanmi Juárez and Álex Estévez. The three of them met in Barcelona after years of training in design schools in Spain, England and Italy, and set off on a creative journey brought together by their common aim of finding the extraordinary in the ordinary.

MERMELADA STUDIO Mermelada Studio es un estudio de diseño industrial integrado por Laura Blasco, Juanmi Juárez y Alex Estévez. Después de formarse en diferentes universidades y estudios de España, Inglaterra e Italia, decidieron emprender desde Barcelona su propia aventura creativa y dar rienda suelta a su forma de entender el diseño. Para ellos, cada proyecto es un viaje en el que buscan lo especial en lo cotidiano.

Collection MOMENTOS

Designed by Andrés Martínez. Seductive objects which transform our daily life aspects into luxurious moments, functional pieces providing pleasant sensations of well-being.

Diseñada por Andrés Martínez. Objetos seductores que transforman aspectos de nuestra vida cotidiana en momentos de bienestar, piezas funcionales que nos hacen la vida más agradable.





Momentos TOCADOR

Sophisticated Tocador (vanity table) inspired in a sensible woman.

*Finish in black stained ash with Sahara Noir marble.

Sofisticado Tocador inspirado en una mujer sensible.

*Acabado en fresno negro con mármol Sahara Noir.







Its jewelry box and softness shapes allure femininity to the design. Accompanied by a pouf/ottoman upholstered in velvet and silk trimming.

* Finish in natural walnut and upholstered in beige velvet.

La original cajita joyero y la suavidad de sus formas le aportan feminidad. Le acompaña un pouf tapizado en terciopelo con pasamanería de seda.

*Acabado en nogal natural y pouf tapizado beige.









Momentos MESA VAIVÉN

Attractive side table with a functional swivel top.

Mesa atractiva y funcional gracias al movimiento giratorio de sus sobres.



Its wood turned piece holding the superior top creates
a visual element with balance and lightness.
The marble base contributes with prestige to the design.

El sutil torneado que sostiene el sobre superior
crea un juego visual de equilibrio y ligereza.
El mármol de la base aporta prestigio a la pieza.





Momentos RECIBIDOR

Furniture for Hallway or Dressing areas, to place your keys and accessories when arriving home.

Mueble de recibidor o vestidor, donde dejar las llaves y accesorios al llegar a casa.







Timeless piece due to its minimalist and warm design. The original gold rod sophisticates the traditionality of the piece.

Pieza atemporal gracias a su diseño minimalista y cálido. La original varilla llavero sofisticada su funcionalidad.



Momentos GALÁN W
Jewelry furniture for your dressing space.
Su diseño lo convierte en una joya para nuestro vestidor.







Its innovative design integrates a whimsical jewelry box made of polished brass and a natural walnut shelf.
El original diseño integra un coqueto joyero de latón pulido con una bandeja de nogal natural.



Momentos GALÁN M

We have recovered the valet stand updating the piece and renewing its functionality.
Recuperamos el galán actualizando la pieza y renovando su funcionalidad.







New concept of the classic suit valet, a seductive object that transforms our daily life.
Es un concepto nuevo del clásico galán de noche, un objeto seductor que transforma nuestra vida diaria.





Momentos TOALLERO

Towel stand inspired in the art gallery pedestals.
Toallero inspirado en los pedestales de las galerías de arte.



Towel stand with a subtle and delicate design that sophisticates your bathroom.

Toallero sutil y delicado que sofisticata la zona de baño.





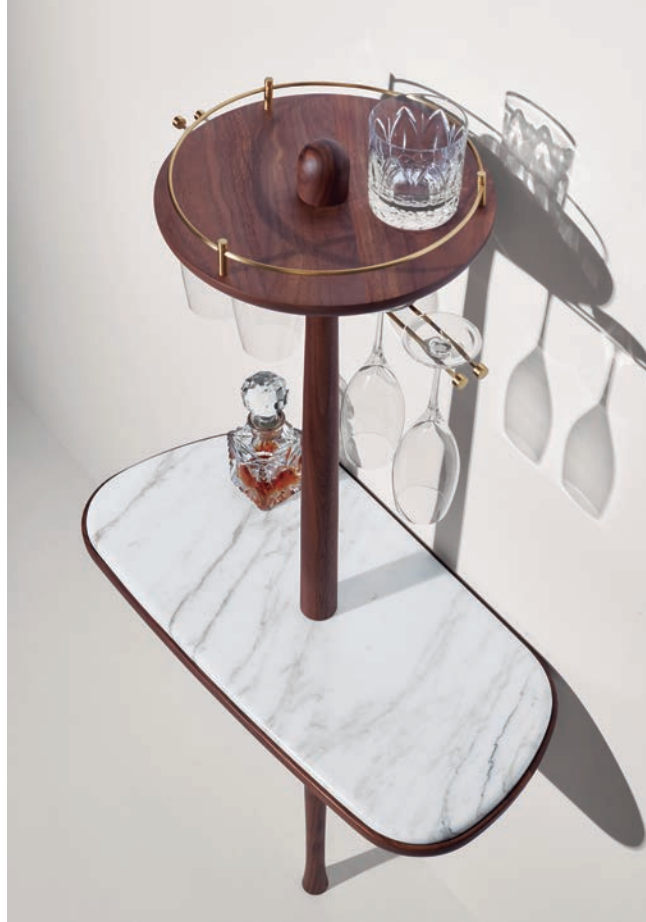

Momentos BAR

We create a space to enjoy a drink in good company.
Creamos un espacio para beber en buena compañía.



Marble top and suspended glasses from the Golden rods evoke classical bar cabinets.
La barra de mármol y las copas suspendidas de las varillas doradas evocan a las coctelerías clásicas.



Singular design to complement your dining décor.
Mini bar que complementa la zona de comedor.





Momentos CHAMPAGNERA

A unique piece to enjoy at home or in your favourite restaurant.
Una pieza única para disfrutar en casa o en tu restaurante favorito.



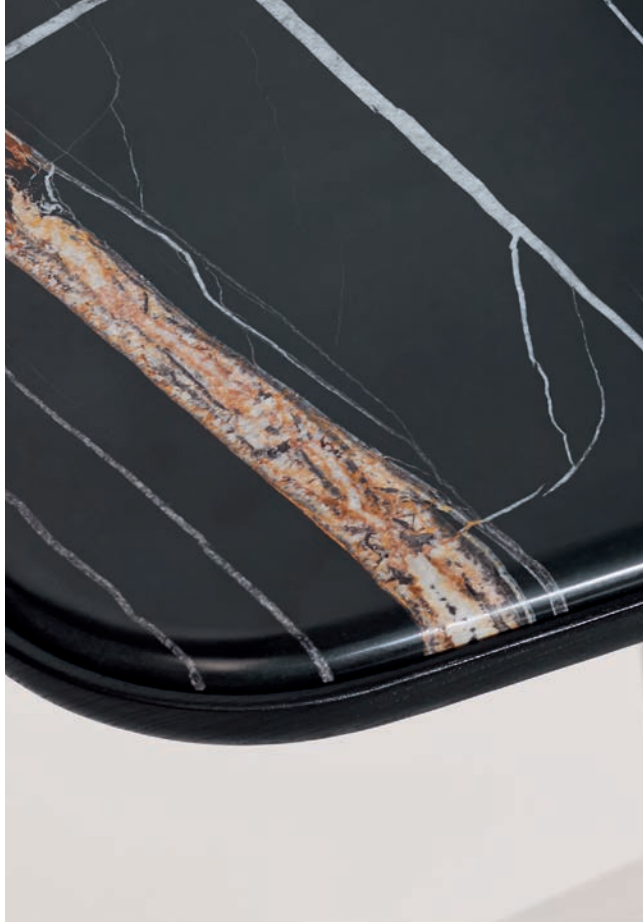

Momentos CONSOLA
Simplicity is the essence of its appeal.
La sencillez es la esencia de su atractivo.



Emperador marble is a natural stone, elegant and exquisite with ranging tones from pearl to chocolate.

El mármol Emperador es una piedra natural, exquisita y elegante con distintos tonos desde el perla hasta el chocolate.

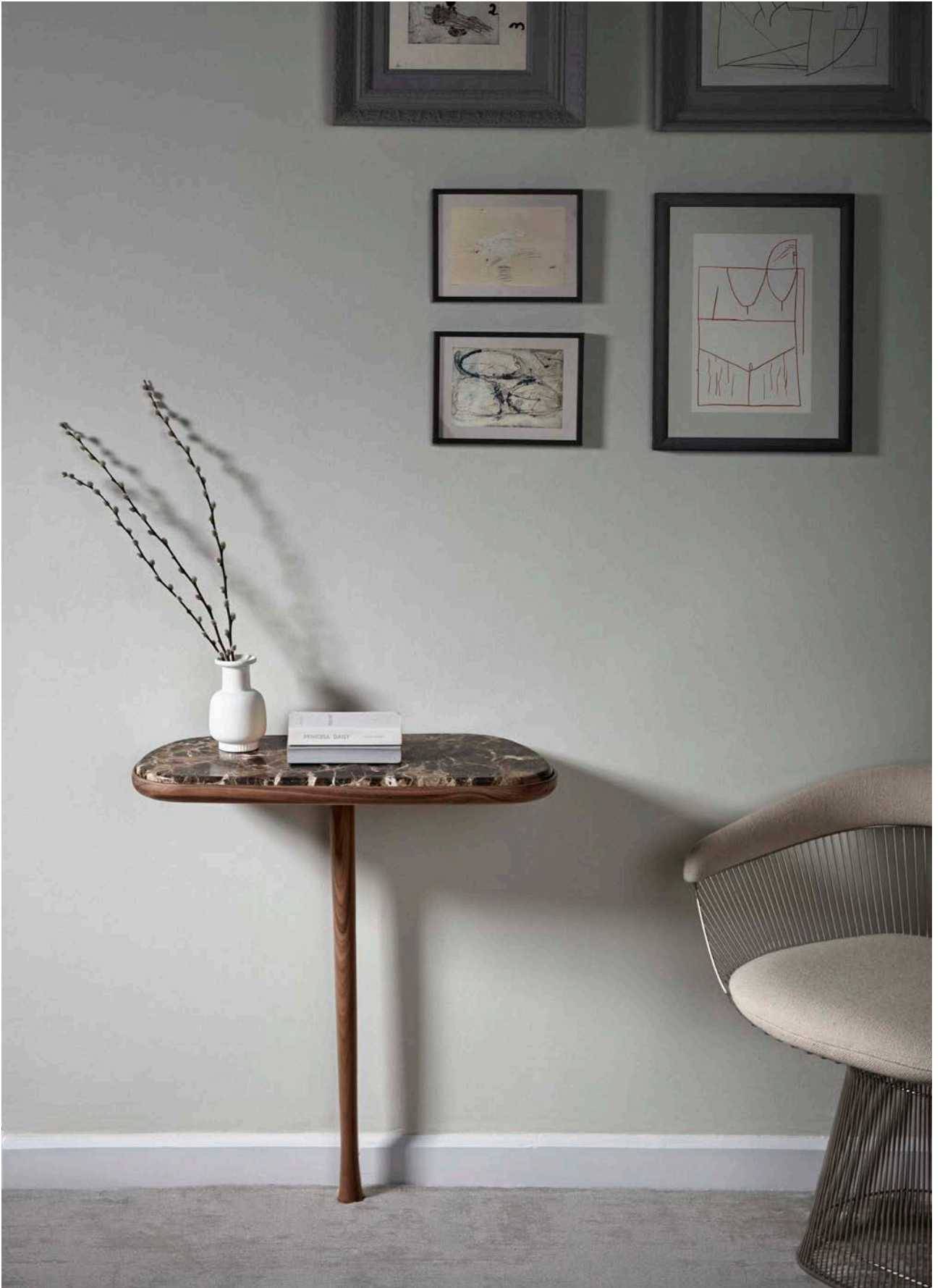



Momentos MESITA M

Versatile and contemporary design to complement a sofa or as night-side table

*Finish in natural walnut and Calacatta Gold marble.

Diseño versátil y contemporáneo ideal junto al sofá o como mesita de noche.

*Acabado nogal natural con mármol Calacatta Gold.







Momentos ESPEJO

The singularity of this mirror is based on its caring proportions.
La singularidad de este espejo recae en sus cuidadas proporciones.





Two options with floor-standing mirror or wall-mirror; a hand-made natural walnut shelf combines the softness lines of the mirror.

El espejo de pie o de pared destaca por la original bandejita de nogal natural de líneas suaves realizada a mano.





Momentos ESPEJO BRISA

Original mirror made with subtly
folded natural walnut sheets, creating a volume that evokes nature.
Mirror available in silver and bronze finish.

Original espejo formado por hojas de nogal natural sutilmente
curvadas, creando un volumen que evoca la naturaleza.

Espejo disponible en plata y bronce.





Momentos ESPEJO ESLABÓN

Sophisticated mirror, with curved rod in brass or black finish.
Sofisticado espejo con varilla curvada acabada latón pulido o negro.





Momentos ARCO

Elegant and functional clothes rack, perfect for a distinguished boutique hotel, as well as a residential or commercial project.

Elegante y funcional vestidor, perfecto para un distinguido hotel boutique, proyecto residencial o comercial.



Momentos ARCO

Stylish clothes rack composed of a metal structure in brass or graphite finish, with a walnut shelf and completed with a Sahara Noir marble plate.

Estiloso vestidor de estructura metálica acabada latón o grafito, con repisa de nogal y rematado con una bandeja de mármol Sahara Noir.



Collection ÚNICA

Designed by Andrés Martínez. Única collection is born with the aim of the user to participate in the design of the furniture, offering in a simple and intuitive way infinite possibilities.

Diseñada por Andrés Martínez. La colección Única nace con el objetivo de que el usuario participe en el diseño del mobiliario, ofreciendo de un modo simple e intuitivo infinitas posibilidades.







Única ESTANTERÍA

Functional system to adapt your design needs transforming the space.
Sistema funcional que se adapta a tus necesidades transformando el espacio.





Simplicity of design and easy installation.
Destaca la simplicidad de su diseño y la fácil instalación.

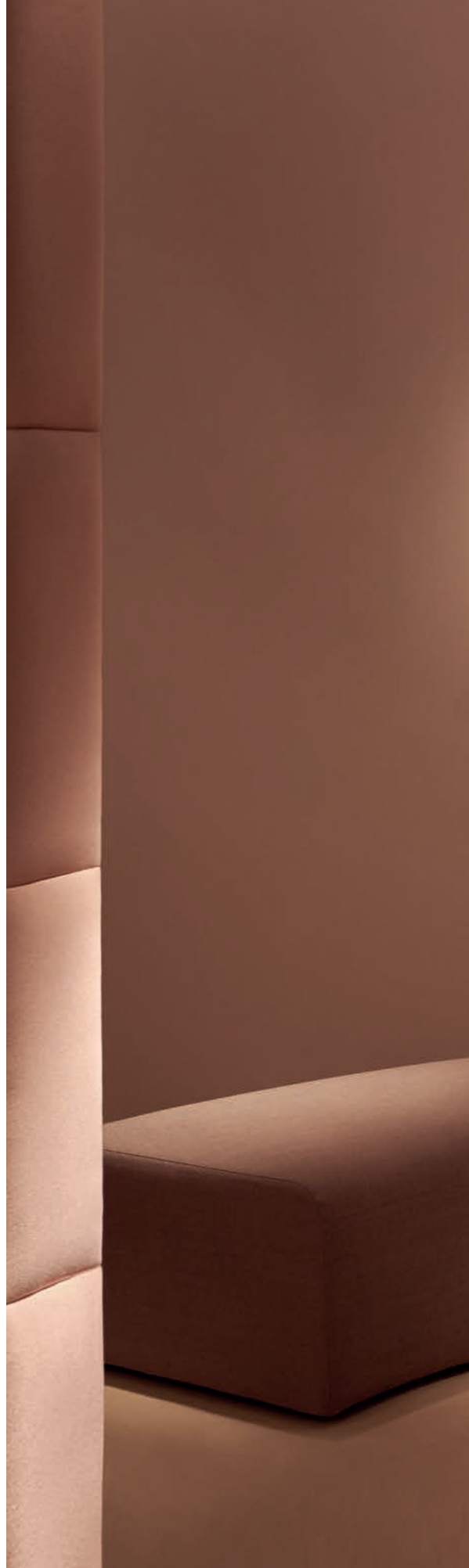

Contemporary classicism in its design and exquisite artisan execution provide elegance, warmth and serenity to this piece.

El clasicismo contemporáneo de su diseño y la exquisita ejecución artesanal le aportan elegancia, calidez y serenidad.









The system can also be adapted to corner installations.
Sorprende la capacidad del sistema que se adapta a la instalación en esquina.



Natural walnut has an important role in aesthetic and is related to tradition, truth and honesty.

El nogal natural tiene un papel importante en la estética y se relaciona con la tradición, la verdad y la honestidad.



ÚNICA SYSTEM

Modular structures in which you can design the shelving system combining shelves and rods of different dimensions.

SISTEMA ÚNICA

Es un sistema modular que permite configurar estanterías a medida combinando baldas y tramos de distintas dimensiones.



1. FLOOR OR CEILING INSTALLATION

It can be installed on the floor or suspended from the ceiling, alternating freestanding and fixed shelves.

1. INSTALACIÓN A SUELO O A TECHO

Permite la instalación desde el suelo o fijada al techo, alternando baldas fijas a pared o libres.

2. FRONT OR CORNER SHELVING

Allows installation on several positions, combining with flat angled walls.

2. ESTANTERÍA FRONTAL O ESQUINA

Posibilidad de instalación en cualquier posición, ya sea en una pared plana o una esquina abierta o cerrada.

3. FREESTANDING SHELF

The system allows alternating fixed and freestanding shelves, which can rotate, providing additional functionality.

3. BALDA MÓVIL

El sistema permite alternar baldas fijas a pared y libres que pueden girar, dotándolo de mayor funcionalidad.





Única ÚNICA MESA

Surprising by long proportions and the layout of its walnut legs in diamond-shape.
Sorprenden sus proporciones y la disposición en forma de rombo de sus patas de madera torneada.

Organic design, subtle and essential.
Discreet in height and monochromatic
finish in black or natural walnut.

Diseño orgánico, sutil y esencial. Discreta
en su altura y acabado monocromático
negro o nogal.









Única ESCRITORIO

A contemporary and classic space to be inspired.
Un contemporáneo y exquisito lugar donde inspirarse.





Única ESCRITORIO

Escritorio allows to combine fixed and freestanding shelves, which can rotate, providing additional functionality.

El Escritorio alterna baldas fijas a pared y baldas libres que pueden girar, dotándolo de mayor funcionalidad.

Collection ESCULTURA

A sculpture made by craftsmen,
whose hands embrace a luxury touch.

Una escultura realizada por artesanos, donde la
caricia de una mano le aporta un toque de lujo.

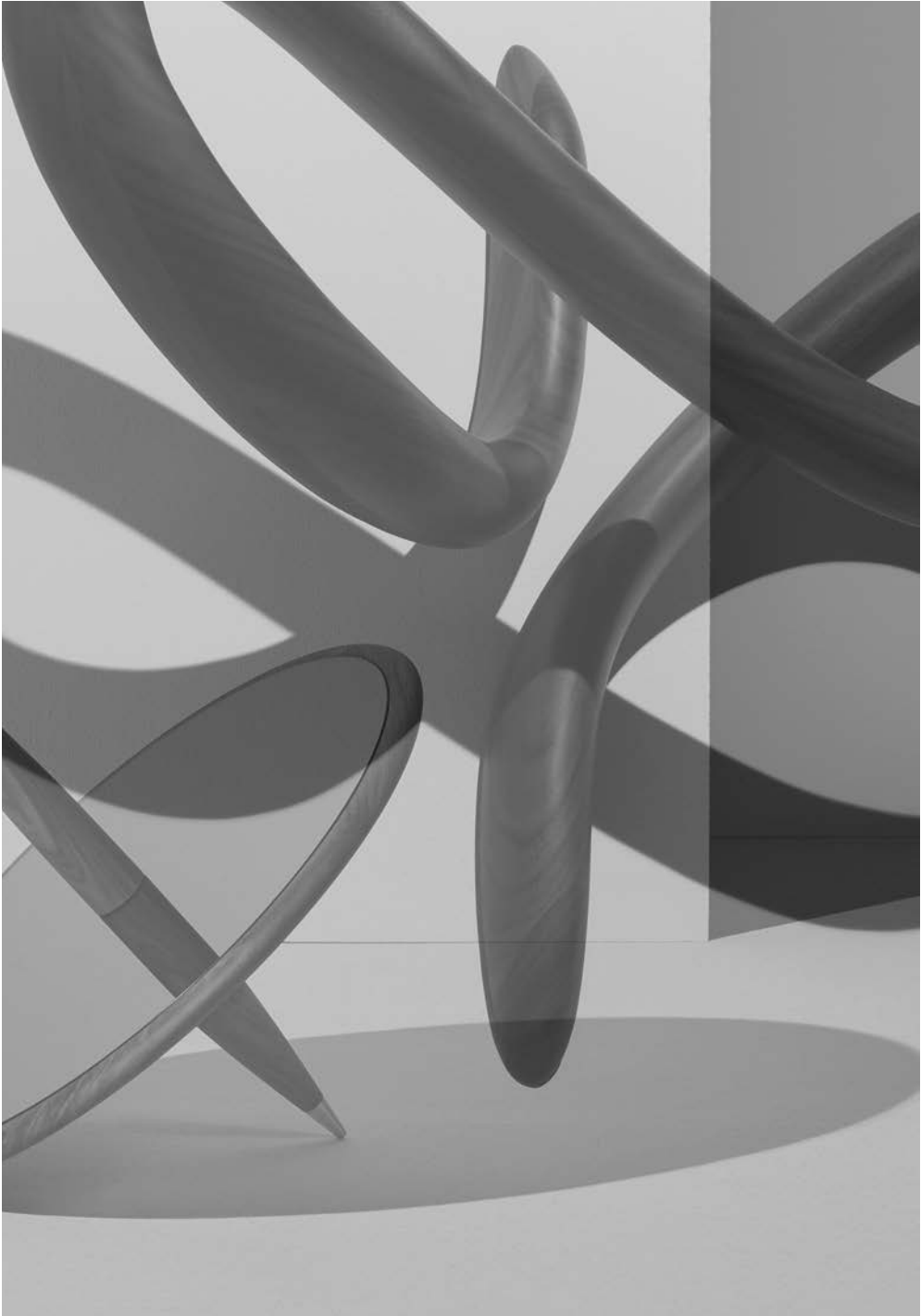



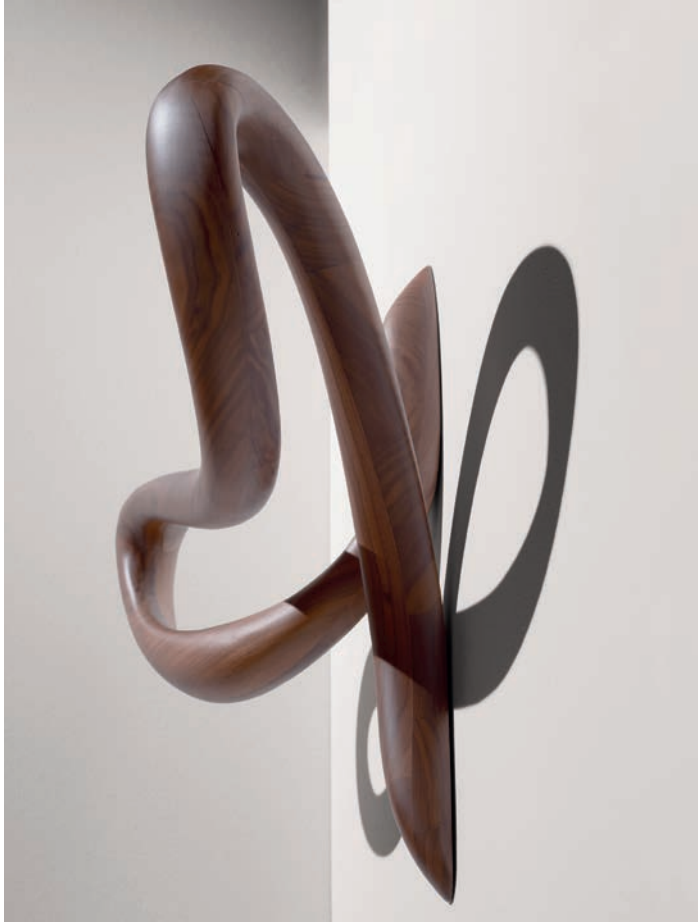

Escultura VERTIGO

Timeless sculpture, its aesthetic function expresses a unique lifestyle.
Atemporal pieza escultórica, su función estética expresa un estilo de vida.







Escultura PEONZA

Tribute to the spinning top and childhood games.
Homenaje a la peonza y juegos de la infancia.







Our Spinning Top is also a whimsical floor mirror.
La Peonza funciona como un divertido espejo de suelo.





Escultura RARA AVIS

Rara Avis is a dialogue between art and design
that transforms an everyday object into an artistic element.
Designed by Mermelada Estudio and Miquel Aparici.

Rara Avis es un diálogo entre arte y diseño,
que transforma un objeto cotidiano en un elemento artístico.
Diseñado por Mermelada Estudio y Miquel Aparici.



It combines geometric shapes in walnut wood with the formal refinement of Rosso Levanto marble. An eccentric object of cubist influence.
Combina formas geométricas en nogal y el refinamiento formal del mármol Rosso Levanto. Un objeto excéntrico de influencia cubista.







Collection MIXTA

Its compelling design provides configurations of side tables with different dimensions combining walnut with marble – Calacatta Gold, Sahara Noir or Emperador.

Su atractivo diseño permite configurar mesas de diferentes dimensiones combinando nogal con mármoles Calacatta Gold, Sahara Noir o Emperador.







Mixta MESA MIXTA TRÍO

When design invites you to participate in its creation.

In this configuration the central element is Sahara Noir marble.

Su diseño invita a participar en la creación.

En esta ocasión con el elemento central en mármol Sahara Noir.









Mixta MESA MIXTA DÚO

Elegant table with a strong personality and big presence which will not go unnoticed.
Elegante mesa de fuerte personalidad y gran presencia que no pasará desapercibida.

Collection WELCOME

It is a presentation of our home and lifestyle,
enhanced by its volume and quality of the
handcrafted wood treatment.

Una tarjeta de presentación de nuestra
vivienda y de nuestro estilo de vida,
potenciado por sus volúmenes, formas
y tratamiento artesanal de la madera.

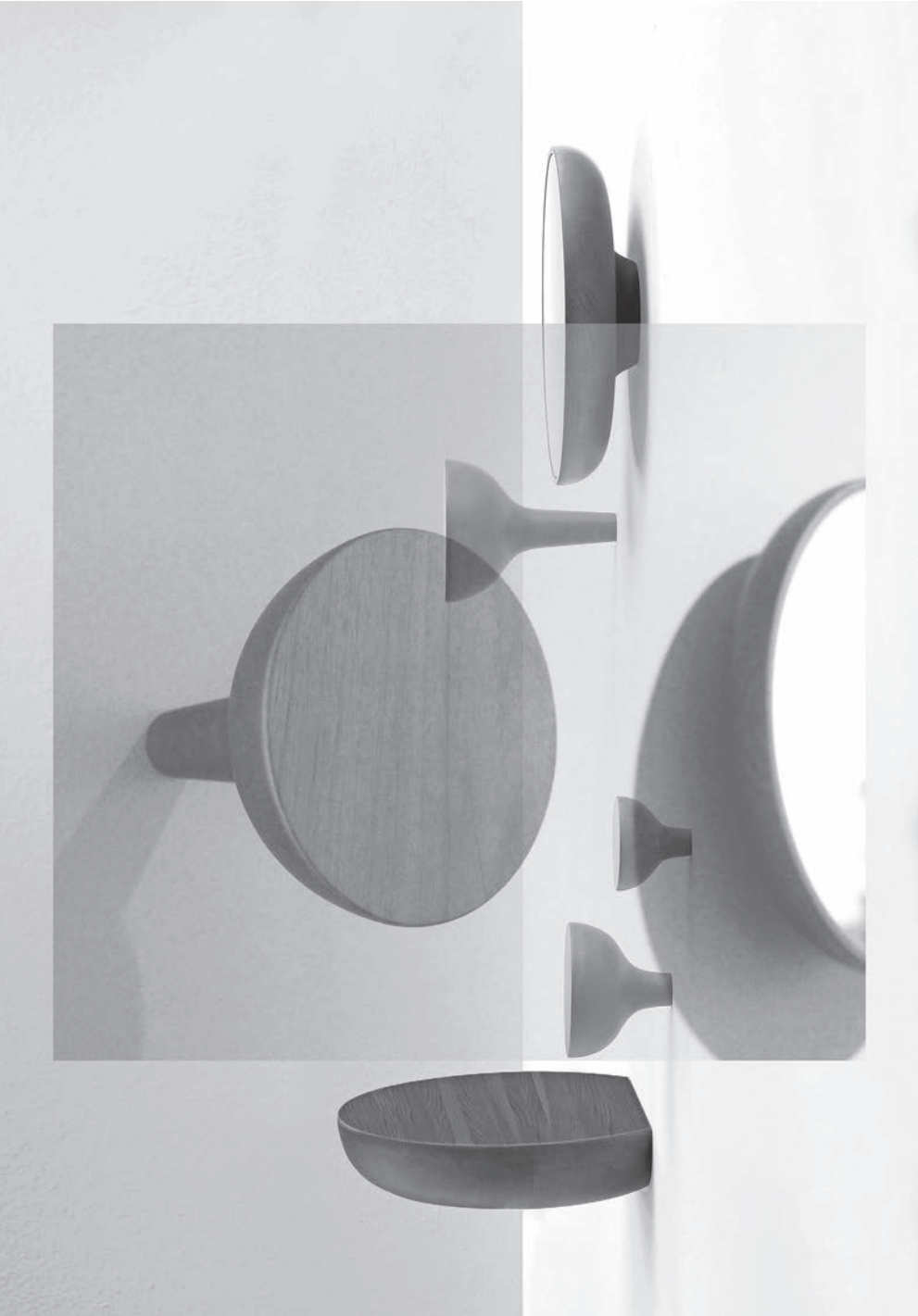





Collection WELCOME

The best way to introduce your home.
Install the mirror, the shelf and the hangers as you like
La mejor manera de presentar tu hogar.
Instala el espejo, la balda y las perchas a tu gusto.

LIGHTING COLLECTION

Nomon introduces a delicate lighting collection, where simplicity is the essence of its appeal. It stands out for the combination of metallic details with natural hand worked walnut.

Nomon presenta una delicada colección de iluminación, donde la sencillez es la esencia de su atractivo. Destaca por la combinación de detalles metálicos con nogal natural trabajado a mano.





Lighting collection LINEA D
Sculptural floor lamp of warm and indirect ambient light.
It creates an intimate and enveloping atmosphere.
Escultórica lámpara de pie de luz ambiental cálida e indirecta,
creando una atmosfera íntima y envolvente.







Wood craftsmanship conveys quality
and warmth in the purity of its forms.
La artesanía de la madera transmite calidad
y calidez en la pureza de sus formas.



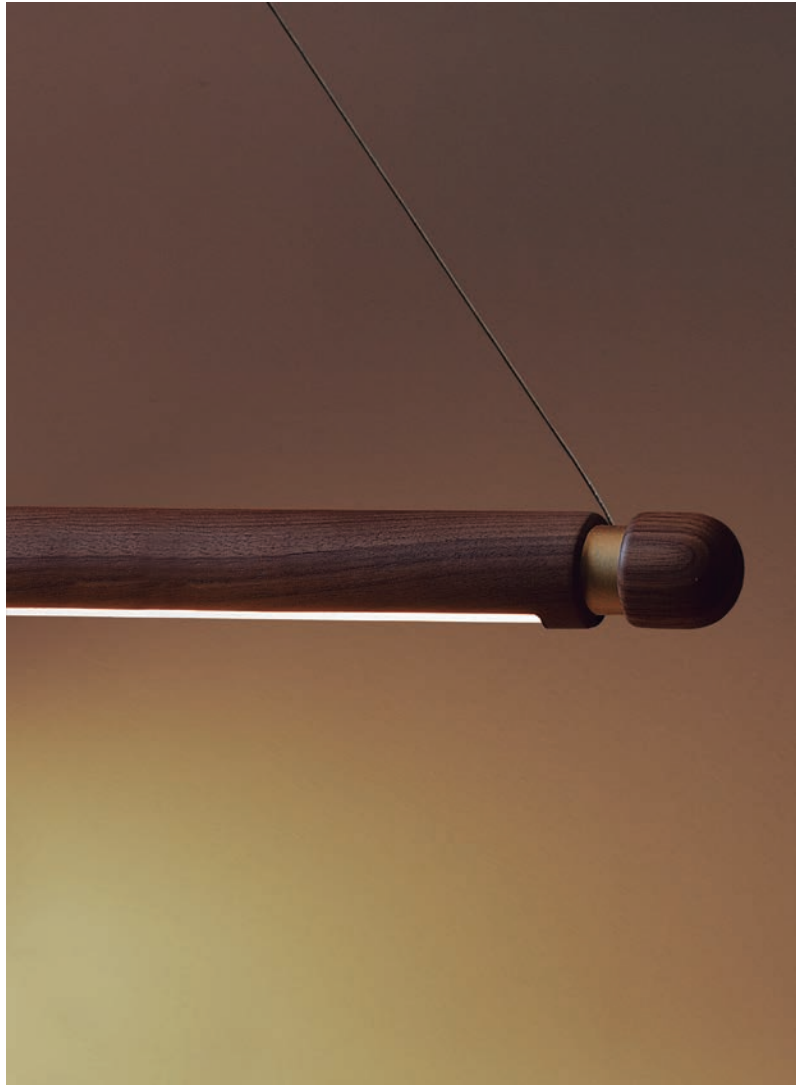

Lighting collection LINEA H
Suspended in the air, its originality lies
in natural walnut wood body.
Suspendida en el aire, su originalidad radica
en el cuerpo de madera de nogal natural.



Lighting collection LINEA V
Delicate and light design where the warmth of walnut
wraps a cozy ambient lighting.
Diseño delicado y ligero donde la calidez del nogal
viste una luz de ambiente acogedora.







Lighting collection LINEA UNO

Elegant floor lamp that combines a marble base and turned walnut body. A design of exquisite simplicity.

Elegante lámpara de pie que combina base de mármol y cuerpo de nogal torneado. Un diseño de exquisita simplicidad.

TECHNICAL INFORMATION

RECIBIDOR Hallway Furniture

MODEL	REF.
Recibidor Nogal/Walnut	CON
Recibidor Nogal/Mármol Emperador Hallway Walnut/Emperador marble	CONME
Recibidor Fresno Negro/Sahara Noir Hallway Black Ash/Sahara Noir	COBMS

* El espejo puede ajustarse a dos alturas y a dos posiciones:

* Mirror can be adjusted in two heights and two positions:

Vertical mirror · 172 / 180 cm Horizontal mirror · 157 / 164 cm

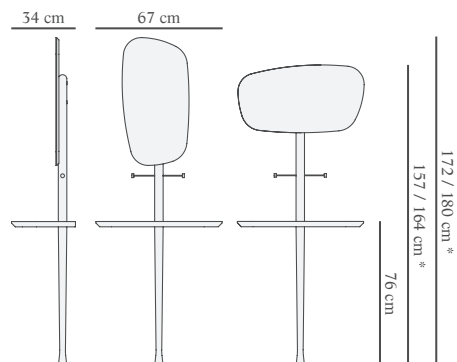

TOCADOR Vanity table

MODEL	REF.
Tocador Nogal/Walnut	TON
Tocador Nogal/ Mármol Emperador Vanity Walnut/Emperador marble marble	TONME
Tocador Fresno Negro/Sahara Noir Vanity Black Ash/Sahara Noir	TOBMS

Material: Nogal natural o fresno teñido negro y detalles de latón pulido.

Material: Natural walnut or black stained ash and polished brass accessory.

Mármoles en stock: Emperador, Sahara Noir y Calacatta Gold.

Marbles in stock: Emperador, Sahara Noir and Calacatta Gold.

MODEL	REF.
Puf terciopelo rosa Pouf blush pink velvet	PTTR08
Puf terciopelo gris Pouf pewter grey velvet	PTTG10
Puf terciopelo crema Pouf sesame cream velvet	PTTC17
Puf tela cliente Pouf client's fabric	PTC

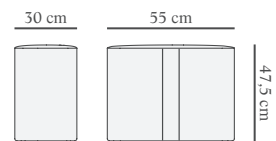
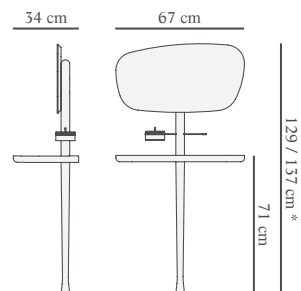

*Posibilidad de usar tela cliente:
Dimensiones tela: 1,40 m de ancho por 1,80 m de largo para 1 y 2 pufs.
Possibility to use client fabric:
Fabric dimensions: 1,40 m wide by 1,80 m long for 1 and 2 poufs.

BAR Bar cabinet

MODEL	REF.
Bar Nogal/Mármol Emperador Bar Walnut/Emperador marble	BNMG
Bar Fresno negro/Sahara Noir Bar Black ash/Sahara Noir	BBMSG

Material: Nogal natural o fresno teñido negro y detalles de latón pulido.

Material: Natural walnut or black stained ash and polished brass accessory.

Mármoles en stock: Emperador, Sahara Noir y Calacatta Gold.

Marbles in stock: Emperador, Sahara Noir and Calacatta Gold.

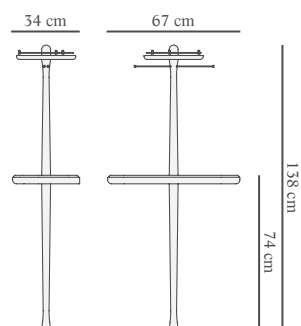

CHAMPAGNERA Champagne bucket

MODEL	REF.
Champagnera G	CHNMD
Champagnera T	CHNMT

Material: Nogal natural o fresno teñido negro, cubitera de cristal y base de mármol.

Material: Natural walnut or black stained ash, glass ice bucket and marble base.

Mármoles en stock: Emperador, Sahara Noir y Calacatta Gold.

Marbles in stock: Emperador, Sahara Noir and Calacatta Gold.

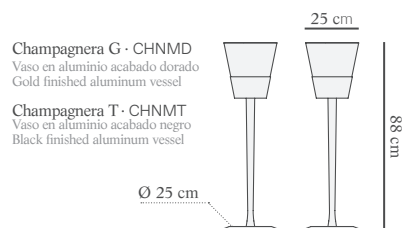

GALÁN M Valet Stand M

MODEL	REF.
Galán M Nogal / Grafito / Mármol Emperador Galán M Walnut / Graphite / Emperador marble	GANMNTEM
Galán M Fresno teñido negro / Grafito / Mármol Sahara Noir Galán M Black stained ash / Graphite / Sahara Noir marble	GANMBTSA

Base: Mármol

Conjunto: Nogal natural macizo o fresno teñido negro

Accesorios: Latón pulido o acabado grafito

Percha: Nogal natural, fabricada por Toscanini

Base: Marble

Set: Natural solid walnut or black stained ash

Accessories: Polished brass or graphite finish

Hanger: Solid walnut, manufactured by Toscanini

Mármoles en stock: Emperador, Sahara Noir y Calacatta Gold.

Marbles in stock: Emperador, Sahara Noir, and Calacatta Gold.

Opción piezas metálicas doradas.

Optional metal parts in gold finish.

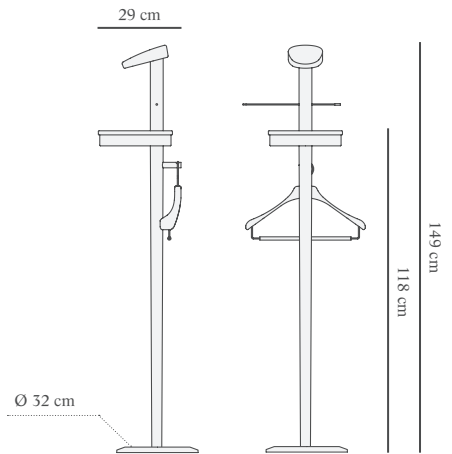

GALÁN W Valet Stand W

MODEL	REF.
Galán W Nogal / Dorado / Mármol Emperador Galán W Walnut / Gold / Emperador marble	GANFNGEM
Galán W Fresno teñido negro / Dorado / Mármol Sahara Noir Galán W Black stained ash / Gold / Sahara Noir marble	GANFBGSA

Base: Mármol

Conjunto: Nogal natural macizo o fresno teñido negro

Accesorios: Latón pulido o acabado grafito

Percha: Nogal natural, fabricada por Toscanini

Base: Marble

Set: Natural solid walnut or black stained ash

Accessories: Polished brass or graphite finish

Hanger: Solid walnut, manufactured by Toscanini

Mármoles en stock: Emperador, Sahara Noir y Calacatta Gold.

Marbles in stock: Emperador, Sahara Noir, and Calacatta Gold.

Opción piezas metálicas grafito.

Optional metal parts in graphite finish.

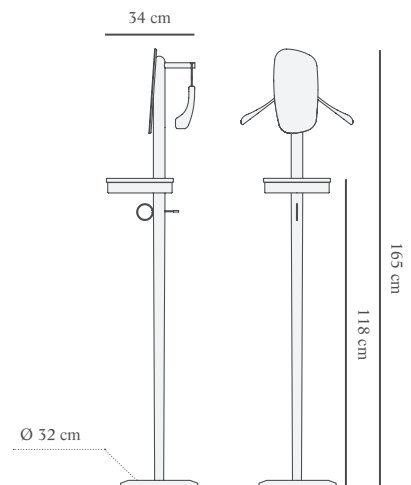

TOALLERO Towel Stand

MODEL	REF.
Toallero Nogal / Mármol Emperador Towel stand N Walnut / Emperador marble	TOANE
Toallero Fresno teñido negro / Mármol Sahara Noir Towel stand Black stained ash / Sahara Noir marble	TOABS

Base y bandeja: Mármol

Conjunto: Nogal natural macizo o fresno teñido negro

Varillas: Latón pulido o latón pintado negro

Base and plate: Marble

Set: Natural solid walnut or black stained ash

Rods: Polished brass or brass painted in black

Mármoles en stock: Emperador, Sahara Noir y Calacatta Gold.

Marbles in stock: Emperador, Sahara Noir, and Calacatta Gold.

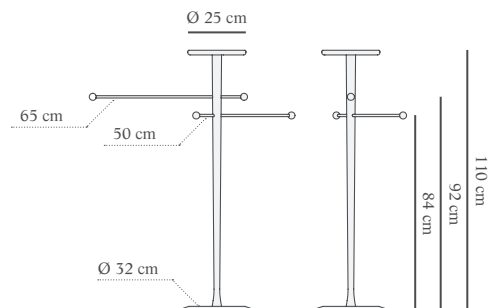

ESPEJO PIE Floor Mirror

MODEL	REF.
Espejo de Pie Nogal / Mármol Emperador Floor Mirror Walnut / Emperador marble	ESPFNE
Espejo de Pie Fresno teñido negro / Mármol Sahara Noir Floor Mirror Black stained ash / Sahara Noir marble	ESPFBS

Base: Mármol

Conjunto: Nogal natural macizo o fresno teñido negro

Base: Marble

Set: Natural solid walnut or black stained ash

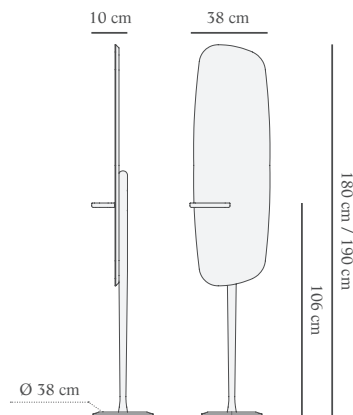

ESPEJO DE PARED Wall Mirror

MODEL	REF.
Espejo Pared Nogal Wall Mirror Walnut	ESPWN
Espejo Pared Fresno teñido negro Wall Mirror Black stained ash	ESPWB

Conjunto: Nogal natural macizo o fresno teñido negro

Set: Natural solid walnut or black stained ash

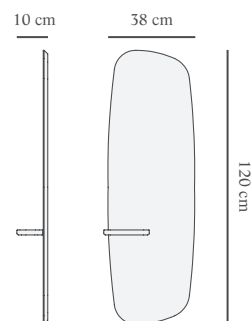

CONSOLA Console table

MODEL	REF.
Consola Nogal / Walnut	CN
Consola Nogal / Mármol Emperador Console Walnut / Emperador marble	CNM
Consola Fresno Negro / Sahara Noir Console Black Ash / Sahara Noir	CNBM

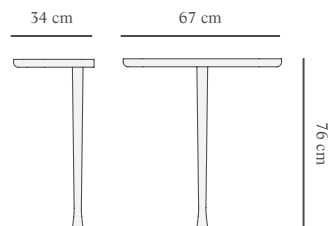

MESITA S & M Table S & M

MODEL	REF.
Mesita S / Nogal Table S / Walnut	MES
Mesita M / Nogal Table M / Walnut	MEM
Mesita M Nogal / Mármol Emperador Table M Walnut / Emperador marble	MEMM

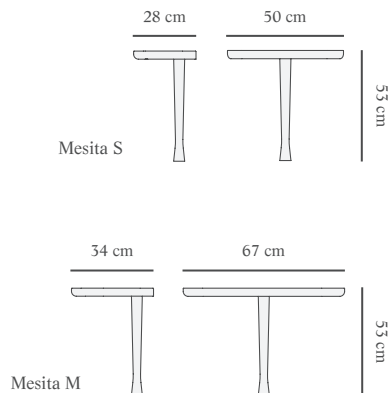

MESA VAIVÉN Vaivén Side Table

MODEL	REF.
Mesa Vaivén N Nogal / Mármol Emperador Vaiven table N Walnut / Emperador marble	VANME
Mesa Vaivén B Fresno teñido negro / Mármol Sahara Noir Vaiven table B Black stained ash / Sahara Noir marble	VABMS

Material: Nogal natural o fresno teñido negro.

Material: Natural walnut or black stained ash veneered.

Mármoles en stock: Emperador, Sahara Noir y Calacatta Gold.

Marbles in stock: Emperador, Sahara Noir, and Calacatta Gold.

El sobre superior permite un movimiento circular para adpatar la mesa a cualquier posición.

The upper top allows a circular movement to adapt the table to any position.

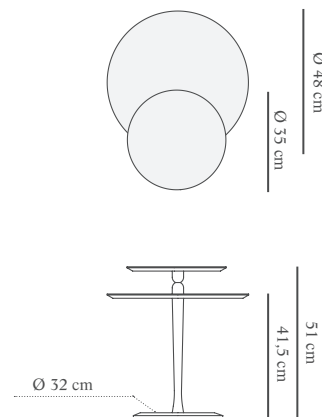

ESPEJO BRISA Brisa Mirror

MODEL	REF.
Chapas en madera de nogal Walnut wood shades	EBRIN
Chapas en madera de nogal, espejo acabado bronce Walnut wood shades, bronze finished mirror	EBRINB

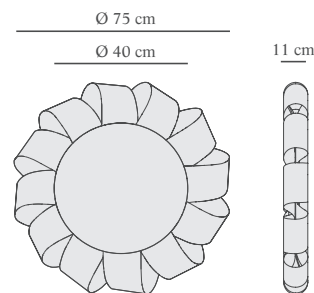

ESPEJO BRISA XL Brisa XL Mirror

MODEL	REF.
Chapas en madera de nogal Walnut wood shades	EBRIXLN
Chapas en madera de nogal, espejo acabado bronce Walnut wood shades, bronze finished mirror	EBRIXLNB

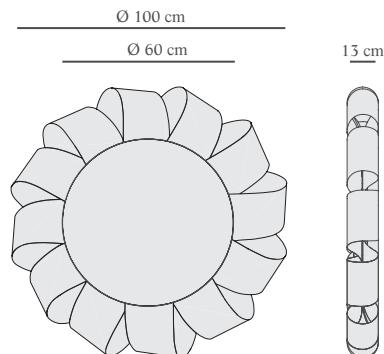

ESPEJO ESLABÓN Eslabon Mirror

MODEL	REF.
Espejo en nogal / Aro acabado dorado Mirror in walnut /ring in gold finish	EESLGN
Espejo en nogal / Aro acabado negro Mirror in walnut /ring in black finish	EESLNN

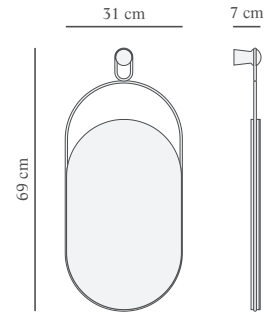

ARCO

Fabricado en España de forma artesanal.
Repisa en madera chapada nogal natural. Estructura superior metalica en metal acabado latón.
Patasy bases en metal acabado latón o grafito. Bandeja de nogal natural o mármol Sahara Noir.

Manufactured in Spain following artisanal methods.
Shelf in natural walnut veneered wood. Metal upper structure in brass or graphite finished metal.
Legs and bases in brass finished metal. Plate in natural solid walnut or Sahara Noir marble.

CONFIGURACIONES SUGERIDAS SUGGESTED CONFIGURATIONS

MODEL	REF.
Arco · Gold/ Walnut Arco · Black/ Sahara Noir	ARCNGN * ARCNSA *
Arco 1 · Gold/ Walnut Arco 1 · Black/ Sahara Noir	ARCNGN01 ARCNSA01
Arco 2 · Gold/ Walnut Arco 2 · Black/ Sahara Noir	ARCNGN02 ARCNSA02
Arco 3 · Gold Arco 3 · Black	ARCNGN03 ARCNSA03
Arco 4 · Gold Arco 4 · Black	ARCNGN04 ARCNSA04
Hanguer · Gold/ Walnut Hanguer · Black/ Walnut	PERNG01 PERNB01

ESPECIFICACIONES SPECIFICATIONS

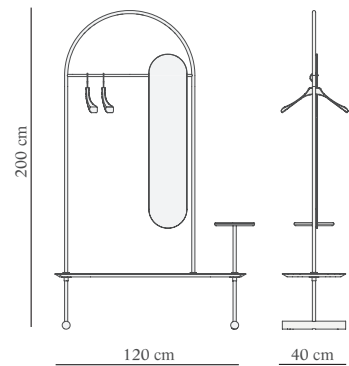

ARCO

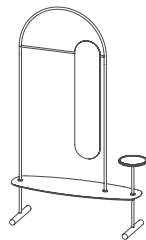

ARCO 1

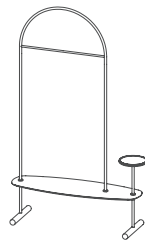

ARCO 2

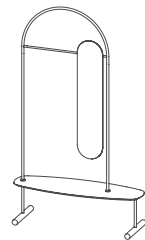

ARCO 3

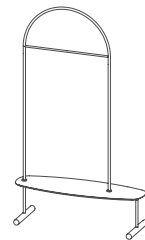

ARCO 4

* 2 hangers included
* 2 perchas incluidas

ESTANTERÍA ÚNICA Única shelf system

TRAMOS Y TERMINALES RODS & TERMINALS

MODEL _____ REF. _____

Tramo en Nogal natural
Rod in natural solid walnut

ROD

- 1 · Pata/Leg 40 cm · Ø4cm
- 2 · Pata/Leg 70 cm · Ø4cm
- 3 · Tramo/Rod 25 cm · Ø4cm
- 4 · Tramo/Rod 40 cm · Ø4cm
- 5 · Tramo/Rod 60 cm · Ø4cm
- 6 · Tramo/Rod 80 cm · Ø4cm
- 7 · Tramo/Rod 120 cm · Ø4cm
- 8 · Terminal 8 cm · Ø4cm

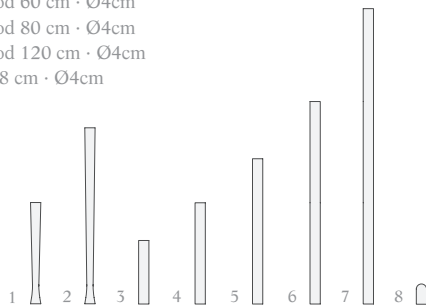

BALDAS SHELVES

MODEL _____

S Air Nogal natural macizo / Natural solid walnut
S Air Lacado negro / Black lacquered
S Air chapado nogal o fresno negro / Walnut or black ash veneered

S Fix Nogal natural macizo / Natural solid walnut
S Fix Lacado negro / Black lacquered
S Fix chapado nogal o fresno negro / Walnut or black ash veneered

M Nogal natural macizo / Natural solid walnut
M Lacado negro / Black lacquered
M chapado nogal o fresno negro / Walnut or black ash veneered

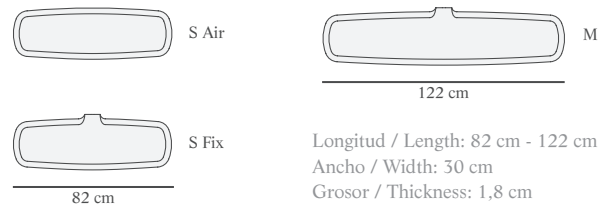

ESCRITORIO Desk

Escritorio modular, formado por un sobre y dos patas de 70 cm, donde a partir de un eje se instalan baldas a derecha e izquierda, alternando baldas fijas a pared y libres.
Modular desk, formed by a desk-top, two legs of 70 cm and a central axis in which you can alternately install floating or fixed to the wall shelves to the right or to the left.

Fabricado en España con madera maciza de nogal.*
Manufactured in Spain with natural solid walnut.*

*Opción chapado nogal natural o fresno teñido negro.
*Options veneered in natural walnut or black stained ash.

ESPECIFICACIONES SPECIFICATIONS

BALDA E / SHELF E

Longitud / Length: 124 cm
Ancho / Width: from 30 cm to 50 cm
Grosor / Thickness: 1,8 cm

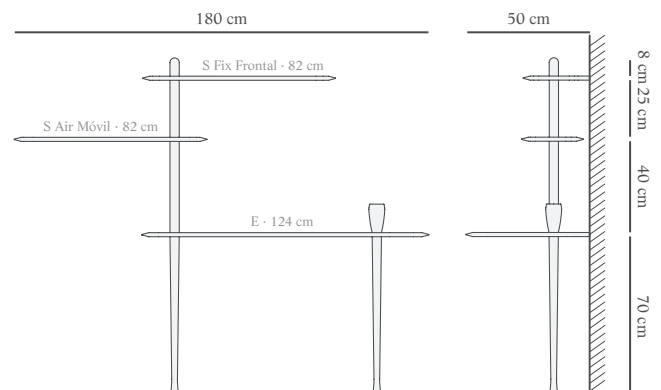
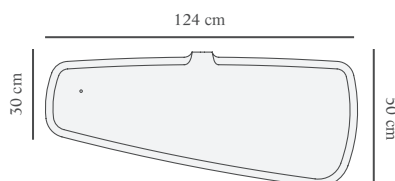

CONFIGURACIONES SUGERIDAS
SUGGESTED CONFIGURATIONS

Configuración 1 / Configuration 1

Baldas S: Nogal natural macizo / Shelves S: Natural solid walnut.
Balda E: Nogal natural macizo / Shelf E: Natural solid walnut.

Configuración 2 / Configuration 2*

Baldas S: Chapado nogal natural / Shelves S: Natural walnut veneered top.
Balda E: Chapado nogal natural / Shelf E: Natural walnut veneered top.

Configuración 3 / Configuration 3*

Baldas S: Chapado fresno teñido negro / Shelves S: Black stained ash veneered top.
Balda E: Chapado fresno teñido negro / Shelf E: Black stained ash veneered top.

* La configuración 2 y 3 no incluye lapicero.

* Configuration 2 and 3 don't include pencil pot.

CONF 1. ESCRITORIO

Escritorio en nogal natural.
Desk in natural solid walnut.

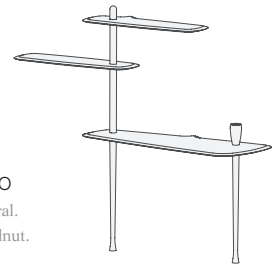

CONF 2-3. ESCRITORIO

Escritorio con baldas chapadas
nogal o fresno negro.
Natural walnut or black ash
veneered shelves.



MESA ÚNICA Long coffee table

Fabricado en España de forma artesanal.
Sobre chapado en nogal natural o fresno teñido negro.
Patatas en nogal natural macizo o fresno teñido negro.
Manufactured in Spain following artisanal methods.
Natural walnut veneered or black stained ash top.
Legs in natural solid walnut or black stained ash.

ESPECIFICACIONES
SPECIFICATIONS

Altura / Height: 26,8 cm
Ancho / Width: 42 cm
Largo / Length: 170 cm
Grosor de la sobre / Top thickness: 18 mm

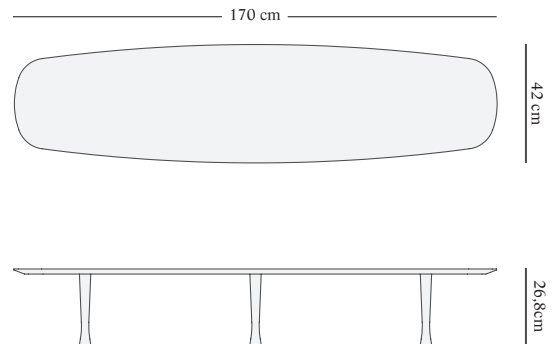

CONFIGURACIONES SUGERIDAS
Suggested configurations

MODEL	REF.
Mesa única · Nogal Única long coffee table · Walnut	MECN
Mesa única · Fresno teñido negro Única long coffee table · Black stained ash	MECBN

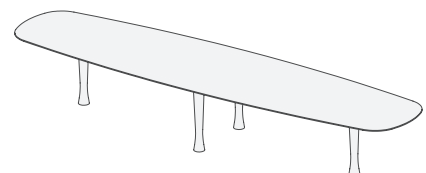

VERTIGO Vertigo

MODEL	REF.
Vértigo S	PVNS
Vértigo L	PVNL

Material: Nogal natural macizo. Fabricado y pulido a mano.
Material: Natural solid walnut. Manufactured and polished by hand.

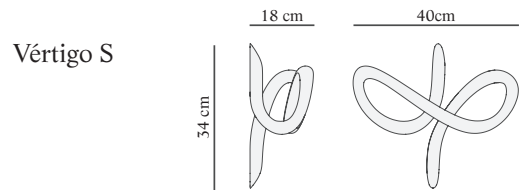
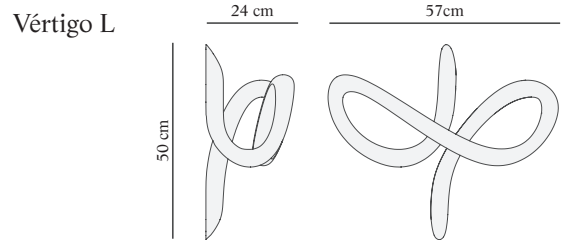

PEONZA Spinning top

MODEL	REF.
Peonza Fresno-Nogal Ash-Walnut Spinning top	PEOFN

Cuerpo en nogal natural macizo y fresno natural macizo.
Espejo acabado bronce.
Detalles en latón pulido.
Fabricado y pulido a mano.
Body in solid natural walnut and solid natural ash.
Mirror finished bronze.
Details in polished brass.
Manufactured and polished by hand.

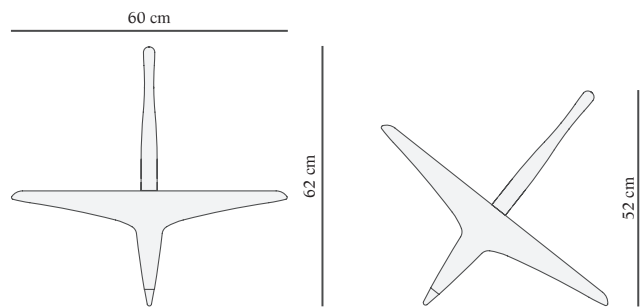

RARA AVIS

MODEL	REF.
Rara Avis 1	RA1NRO
Rara Avis 2	RA2NRO

Cuerpo de madera chapada en nogal natural
Base en mármol rosso levanto.
Body in natural walnut veneered wood.
Base in rosso levanto marble.

Rara Avis 1

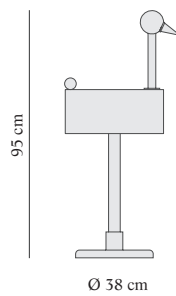

Rara Avis 2

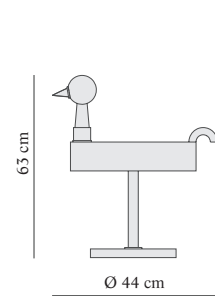

LINEA H

MODEL	REF.
Madera maciza de nogal natural/ Metal acabado latón Natural solid walnut wood/ Brass finished metal	LIHNGD
Madera maciza de nogal natural/ Metal acabado grafito Natural solid walnut wood/ Graphite finished metal	LIHNBD

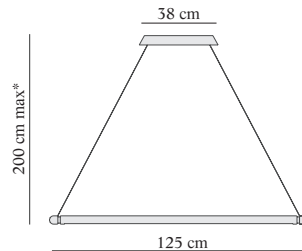

LINEA V

MODEL	REF.
Madera maciza de nogal natural/ Metal acabado latón Natural solid walnut wood/ Brass finished metal	LIVNGD
Madera maciza de nogal natural/ Metal acabado grafito Natural solid walnut wood/ Graphite finished metal	LIVNBD



LINEA D

MODEL	REF.
Madera maciza de nogal natural/ Metal acabado latón Natural solid walnut wood/ Brass finished metal	LIDNGD
Madera maciza de nogal natural/ Metal acabado grafito Natural solid walnut wood/ Graphite finished metal	LIDNBD

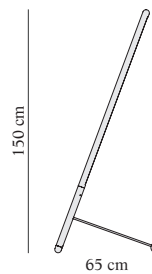

LINEA UNO

MODEL	REF.
Madera maciza de nogal natural/ Metal acabado latón/Mármol Natural solid walnut wood/ Brass finished metal/ Marble	LIUNGSAD
Madera maciza de nogal natural/ Metal acabado grafito/ Mármol Natural solid walnut wood/ Graphite finished metal/ Marble	LIUNBSAD

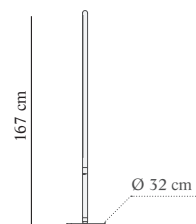

DETALLES TÉCNICOS DE LA LUZ

Light technical information

Fuente de luz: LED Monocolor
Potencia: 0,0132Kw
Flujo Luminoso nominal: 1078-1155lm
CRI: >95
Uniformidad de color: 3 pasos MacAdam
Temperatura de color: 2700-3000-4000-6000K
Apertura: 120°

Light source: LED Monocolor
Power: 0,0132Kw
Nominal Luminous Flux: 1078-1155lm
CRI: >95
Deviation (SDCM): 3 step MacAdam ellipse
Color temperature: 2700-3000-4000-6000K
Light emission 120°

MESA MIXTA DÚO Mixta Duo Coffee Table

Sobres: Mármol o chapado nogal natural.

Estructura: Madera de nogal natural.

Top: Veneered natural walnut or marble.

Structure: Natural solid walnut.

Mármoles: Emperador, Sahara Noir y Calacatta Gold.

Marbles: Emperador, Sahara Noir and Calacatta Gold.

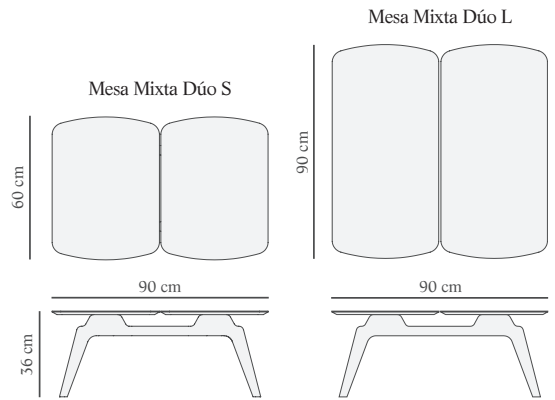

CONFIGURACIONES / CONFIGURATIONS

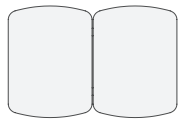

2 S Nogal/Walnut
ref: MIDSNN

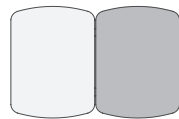

1 S Nogal/Walnut
1 S Mármol/Marble
ref: MIDSNE

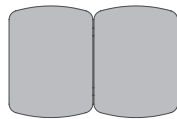

2 S Mármol/Marble
ref: MIDSEE



2 L Nogal/Walnut
ref: MIDLNN

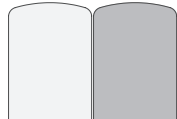

1 L Nogal/Walnut
1 L Mármol/Marble
ref: MIDLNE



2 L Mármol/Marble
ref: MIDLEE

MESA MIXTA TRÍO Mixta Trio Coffee Table

Sobres: Mármol o chapado nogal natural.

Estructura: Madera de nogal natural.

Top: Veneered natural walnut or marble.

Structure: Natural solid walnut.

Mármoles: Emperador, Sahara Noir y Calacatta Gold.

Marbles: Emperador, Sahara Noir and Calacatta Gold.

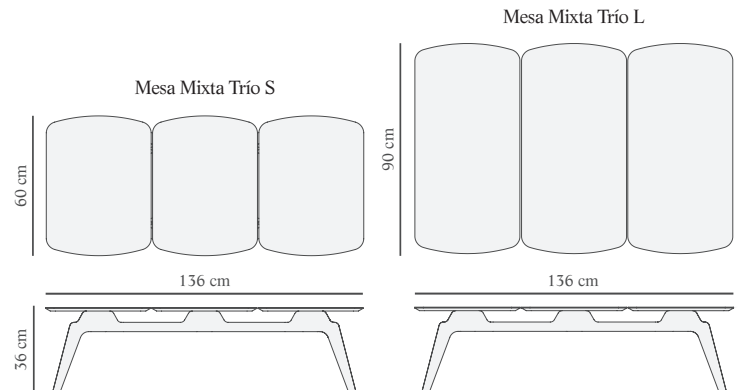

CONFIGURACIONES / CONFIGURATIONS



3 S Nogal/Walnut
ref: MITSNNN



2 S Nogal/Walnut
1 S Mármol/Marble
ref: MITSNNE



1 S Nogal/Walnut
2 S Mármol/Marble
ref: MITSNEE



3 S Mármol/Marble
ref: MITSEE

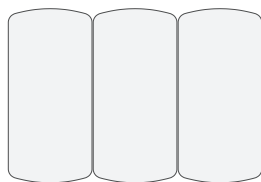

3 L Nogal/Walnut
ref: MITLNNN

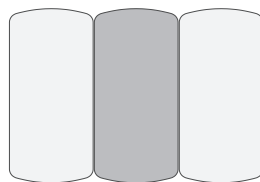

2 L Nogal/Walnut
1 L Mármol/Marble
ref: MITLNNE

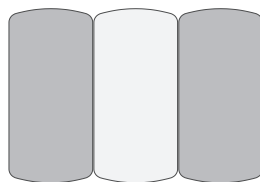

1 L Nogal/Walnut
2 L Mármol/Marble
ref: MITLNEE

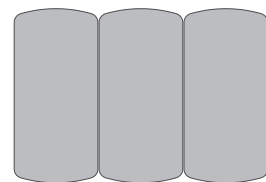

3 L Mármol/Marble
ref: MITLEEE

WELCOME Welcome

MODEL	REF.
Perchas S + M Hooks S + M	WEN0000PSM
Percha L Hook L	WEN0000PXL
Balda Shelf	WEN00000B
Espejo Mirror	WEN00000E

Material: Madera chapada en nogal natural.
Material: Natural solid walnut veneered wood.

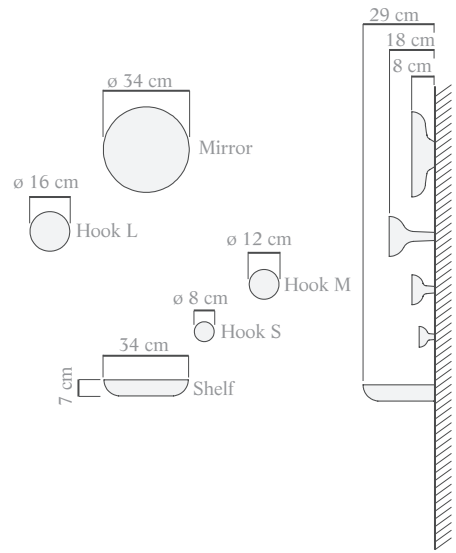

CONFIGURACIONES SUGERIDAS / SUGGESTED CONFIGURATIONS

Welcome 1 · WEN00001

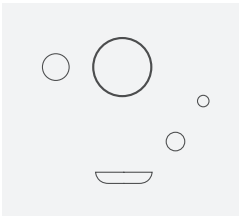

Perchas S + M / Hooks S + M
Percha L / Hook L
Balda / Shelf
Espejo / Mirror

Welcome 2 · WEN00002

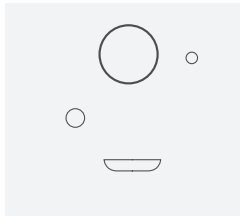

Perchas S + M / Hooks S + M
Balda / Shelf
Espejo / Mirror

Welcome 3 · WEN00003

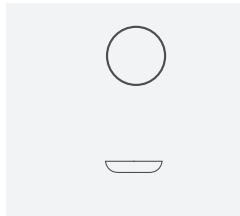

Balda / Shelf
Espejo / Mirror

Welcome 4 · WEN00004

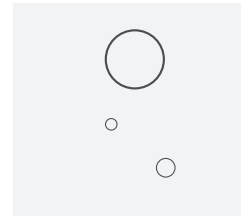

Perchas S + M / Hooks S + M
Espejo / Mirror

PACKAGING

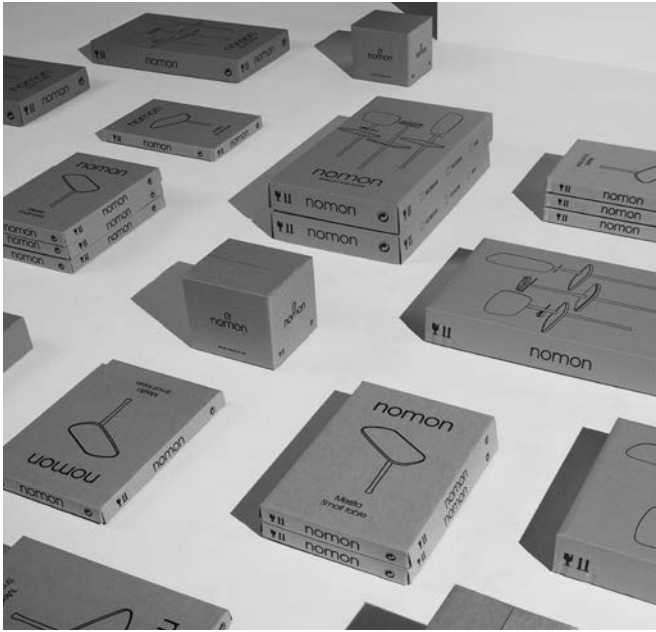

PACKAGING

Our packaging is made of kraft cardboard with an interior foam lining that provides security and lightness for air shipments. The boxes show jewelry interior presentation and design.

Nuestro packaging está fabricado en cartón Kraft con revestimiento interior de espuma que le aporta ligereza y seguridad para envíos aéreos. Diseño y presentación de joyería.

SHIPPING

ESPAÑA Transporte gratuito para pedidos superiores a 180€. Para pedidos inferiores a 180€, coste 12,40€ (IVA no incluido, 15€ IVA incluido).

EUROPEAN UNION Free on orders of over 500€ (excepting to Malta, Croatia and Cyprus). 30€ on orders under 500 € (specific transport quotation available for orders to the countries mentioned).

REST OF THE WORLD Ex-works conditions.

Specific airfreight transport quotation for your order is available. Consolidation of the order at your warehouse, within the European Union, free on orders over 500 €.

DELIVERY TIME

PLACE YOUR ORDER Place your order through our stores, phone or website, consult our office for any specific information.

QUOTATION Right after placing your order by the media chosen you will receive the quotation by an email.

PAYMENT Make the payment following the instructions that you will find in the quotation.

A WEEK AFTER In only seven days you will receive your new product ready to furnish your home.

MOMENTOS COLLECTION

Model	Weight	Dimensions (cm)	Volumetric weight
Recibidor	12,0 kg / 19,5 kg	54 x 95 x 13	13,3 kg
Tocador	12,0 kg / 19,5 kg	54 x 95 x 13	13,3 kg
Puf	10,5 kg	39 x 61 x 50	23,8 kg
Bar	16,5 kg	54 x 95 x 13	13,3 kg
Champagnera	7,0 kg	32 x 29 x 28	5,2 kg
Galán M	9,0 kg	48 x 123 x 12	14,1 kg
Galán W	10,0 kg	48 x 123 x 12	14,1 kg
Toallero	8,6 kg	48 x 123 x 12	14,1 kg
Espejo de pared	13,1 kg	59 x 144 x 11	18,7 kg
Espejo de pie	19,6 kg	59 x 144 x 11	18,7 kg
Espejo Brisa	5 kg	78 x 78 x 21	15,8 kg
Espejo Brisa XL	10 kg	104 x 106 x 18	44 kg
Espejo Eslabón	4,5 kg	86 x 39 x 8	5,4 kg
Consola	7,5 kg / 15 kg	54 x 95 x 7	7,2 kg
Mesita S	4,2 kg	40 x 60 x 7	3,4 kg
Mesita M	7,0 kg / 14,5 kg	54 x 95 x 7	7,2 kg
Vaivén	7,5 kg	55 x 55 x 19	10,6 kg
Arco (Box 1)	22,5 kg	59 x 144 x 11	18,7 kg
Arco (Box 2)	12,5 kg	41 x 51 x 13	5,4 kg

ÚNICA COLLECTION

Model	Weight	Dimensions (cm)	Volumetric weight
Balda S / S Shelf	3,0 kg	35 x 90 x 7	4,4 kg
Balda M / M Shelf	4,3 kg	35 x 130 x 7	6,4 kg
Balda E / E Shelf	7,0 kg	58 x 132 x 7	10,7 kg
Mesa Única	13,5 kg	48 x 186 x 11	19,6 kg

ESCULTURA COLLECTION

Model	Weight	Dimensions (cm)	Volumetric weight
Vértigo L	8,4 kg	40 x 78 x 63	39,4 kg
Vértigo S	4,6 kg	39 x 61 x 50	23,8 kg
Peonza	13,0 kg	80 x 80 x 16	20,5 kg
Rara Avis I	12,0 kg	39 x 61 x 50	23,8 kg
Rara Avis II	12,0 kg	39 x 61 x 50	23,8 kg

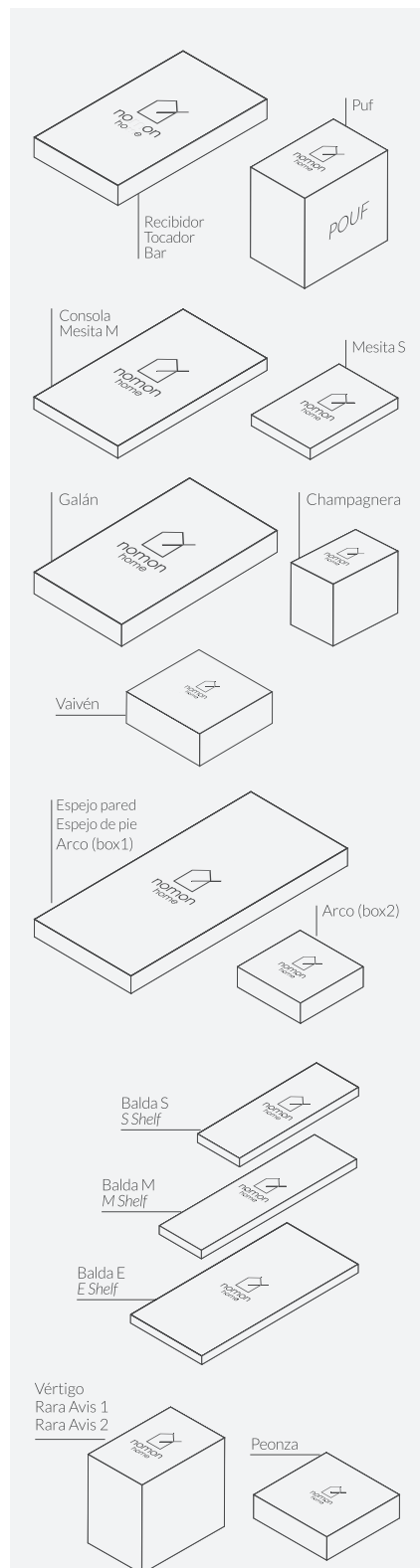

MIXTA COLLECTION

Model	Weight	Dimensions (cm)	Volumetric weight
Mixta patas	6 kg	137 x 45 x 18	22,2 kg
Mixta Sobre S Nogal/Walnut	4,5 kg	71 x 55 x 8	6,3 kg
Mixta Sobre S Mármol/Marble	11,5 kg	71 x 55 x 8	6,3 kg
Mixta Sobre L Nogal/Marble	6,4 kg	101 x 55 x 8	8,9 kg
Mixta Sobre L Mármol/Marble	16,2 kg	101 x 55 x 8	8,9 kg

WELCOME COLLECTION

Model	Weight	Dimensions (cm)	Volumetric weight
Perchas / Hooks S+M	0,6 kg	19 x 19 x 24	1,7 kg
Percha / Hook L	1,0 kg	19 x 19 x 24	1,7 kg
Balda / Shelf	3,5 kg	52 x 42 x 13	5,7 kg
Espejo / Mirror	4,4kg	52 x 42 x 13	5,7 kg

LIGHTING COLLECTION

Model	Weight	Dimensions (cm)	Volumetric weight
Línea H	3,3 kg	19 x 174 x 8	1,7 kg
Línea V	3,2 kg	19 x 174 x 8	1,7 kg
Línea D	4,5 kg	19 x 174 x 8	5,7 kg
Línea Uno	10 kg	37 x 170 x 37	46,5 kg

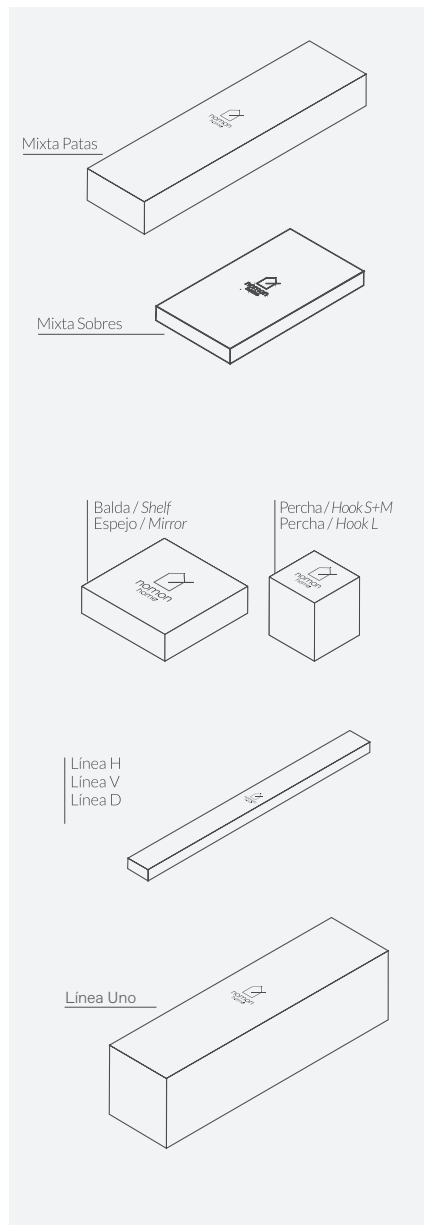

ENVIRONMENT

La sostenibilidad para Nomon se basa en diseñar objetos atemporales de calidad que perdurarán el mayor tiempo posible.

Producir con sentido común y no consumir más de lo necesario, anteponiendo la calidad a la cantidad. Otro pilar esencial en nuestro compromiso sostenible es trabajar con artesanos locales y proveedores de nuestro entorno, lo que reduce la huella de carbono y promueve la economía circular.

For Nomon, sustainability is based on designing timeless quality objects that will last as much as possible. Producing with common sense and avoiding the consumption of unnecessary resources, putting quality before quantity.

Working with local artisans and suppliers is another essential foundation in our commitment to sustainability, as it reduces our products carbon footprint and promotes the circular economy.



Nomon esta adherida a la fundación Eco-RAEE's y está inscrita en el Registro de Aparatos Electricos y Electronicos en cumplimiento del Real Decreto 208/2005. Nomon supports the Eco-WEEE foundation and it is registered in the Register of Electric Appliances and Electronics in compliance with the Royal Decree 208/2005.



Todo nuestros productos son fabricados en Barcelona con procesos manuales y artesanales aplicando técnicas innovadoras. All our products are handmade in Barcelona with manual work and traditional processes using innovative techniques.



Los materiales y procesos productivos cumplen con la directiva RoHS. The materials and production processes comply with the directive RoHS compliant.



Nomon esta adherida a la regulación REACH de la Unión Europea, adoptado para mejorar la protección de la salud humana y el medio ambiente de los riesgos que pueden presentar los productos químicos. Nomon supports REACH regulation of the European Union, adopted to improve the protection of human health and the environment from the risks that can be posed by chemicals.



Todo nuestros productos han superado un procedimiento de evaluación, y cumple los requisitos esenciales de fabricación, diseño, seguridad y salud, recogidas en la normativa de seguridad europea. All our products have passed an evaluation procedure, and meet the essential requirements of manufacturing, design, safety and health, included in the European safety regulations.



Manufacturamos con maderas procedentes de bosques de gestión sostenible. We manufacture with wood coming from sustainably managed forests.



Tocador
P.14-19



Mesa Vaivén
P.20-23



Recibidor
P.24-27



Galán W
P.28-31



Galán M
P.32-35



Toallero
P.36-39



Bar
P.40-43



Champagnera
P.44-45



Consola
P.46-49



Mesita
P.50-51



Espejo
P.52-55



Espejo Brisa
P.56-59



Espejo Eslabón
P.58-59



Arco
P.60-63



Estantería
P.64-73



Mesa Única
P.78-79



Escritorio
P.82-85



Vertigo
P.88-91



Peonza
P.92-95



Rara Avis
P.96-101



Mesa Mixta
P.104-109



Welcome
P.112-113



Linea D
P.116-119



Linea H
P.120-121



Linea V
P.122-123



Linea Uno
P.124-125

ADMINISTRATION

T. (+34) 933 186 585 - ext.2
info@nomon.es

EXPORT

T. (+34) 933 186 585 - ext.3
export@nomon.es

TECHNICAL SERVICE

T. (+34) 933 186 585 - ext.1
produccion@nomon.es

SOCIAL MEDIA

Instagram · nomon_clocks_home
Facebook & Pinterest · Nomon Clocks Home
communication@nomon.es



INSTAGRAM

ACCOUNT



HEADQUARTERS

OFICINAS CENTRALES

Carrer Tucuman, 6 - 2nd floor
08030 BARCELONA
T. (+34) 933 186 585
F. (+34) 933 186 201

NOMON SHOWROOM

Passatge Maiol, 4
08013 BARCELONA
T. (+34) 936 638 497

HEADQUARTERS OPENING HOURS

HORARIO OFICINA

Lunes a Jueves / Monday to Thursday
09:00-14:00 / 15:00-18:00
Viernes / Fridays
08:00-16:00

SHOWROOM OPENING HOURS

HORARIO SHOWROOM

Martes a Viernes / Tuesday to Friday
10:00-14:00 / 15:00-19:00
Sábado / Saturday
11:00-15:00
Lunes cerrado / Monday closed

CREDITS

Art Direction:
Antoni Pallejà Office

Photography:
Marcel Juan
Paco Deogracias
Cualiti Studio

Printing:
9-disseny

Copyright © 2022 Nomon
All rights reserved
Todos los derechos reservados

www.nomonhome.com