

Odyssey armchair  
by Eugeni Quitllet

Casa de Familia bottle  
by Josep Maria Jujol

Explorer family: Cabinet  
and Low table  
by Jaime Hayon

Doobide  
by Alfredo Häberli

Gaulino family: Carlinas  
tables and Gaulino stool,  
Peristylo shelf and Alberto  
candleholder  
by Oscar Tusquets

# Novelties '23

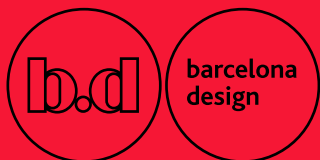



Odyssey armchair  
by Eugeni Quitllet  
p. 3



Explorer cabinet  
by Jaime Hayon  
p. 7



Explorer low table  
by Jaime Hayon  
p. 12



Carlina tables  
by Oscar Tusquets  
p. 15



Gaulino stool  
by Oscar Tusquets  
p. 21



Peristylo shelf  
by Oscar Tusquets  
p. 24



Alberto candleholder  
by Oscar Tusquets  
p. 28



Casa de Familia bottle  
by Josep Maria Jujol  
p. 31



Doobide  
by Alfredo Häberli  
p. 35

# Index

Earth-bound ergonomic forms and  
imaginative flights of fancy meet in an  
out-of-this world armchair.

BY EUGENI QUITLLET



Odyssey armchair

Eugeni Quitllet is designing for his idea of the future. Passionate about science and an avid space enthusiast, Quitllet began his career in the imaginative environment of art school in the Balearic Islands, followed by a diploma in Design and Interior Design here in Barcelona. Back home for the summer, he met Philippe Starck on Formentera, and quickly began work at his agency in Paris. Ten years later, after having created some of the most interesting designs of the early '00s, he opened his own agency in Barcelona. His influences range from Science Fiction to Art Nouveau, the Odyssey chair being a perfect example of both combined, its kinetic and sculptural qualities coming together in a fluid silhouette to beautifully envelop the human body. Beauty, he says, will save the world after all.





# ODYSSEY ARMCHAIR

BY EUGENI QUITLET

## FINISHES

A flexible moulded polyurethane injected foam body, seat cushion and headrest. Both the body and headrest have an integral steel structure. Two adjustable headrest options. Upholstery choices: Monochrome in any of the fabrics and leathers offered by BD. Colour duo combination: The top, seat cushion and headrest are upholstered in the same fabric or leather, and the lower external base are upholstered in another fabric or leather from the BD catalogue. Aluminium swivel base and tilting mechanism in two colours: Matte black or polished die-cast aluminium. Felt glides.

## SIZE

Small headrest  
75 x 81 x h.107 cm  
29,5 x 31,9 x h.42,1 inch

Large headrest  
75 x 81 x h.111 cm  
29,5 x 31,9 x h.43,7 inch



Eugeni Quitlet

## MATERIALS

Discover all our finishes and customize your own version with our online configurator.

## BASE

Polished die-cast aluminium



Aluminium matte black



DISCOVER



Small headrest

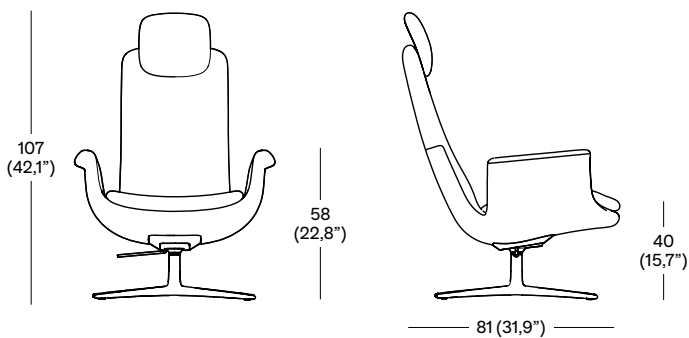

Large headrest

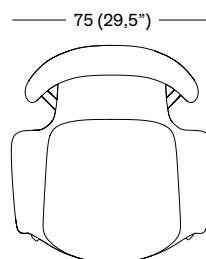
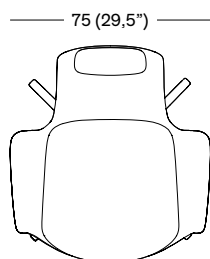
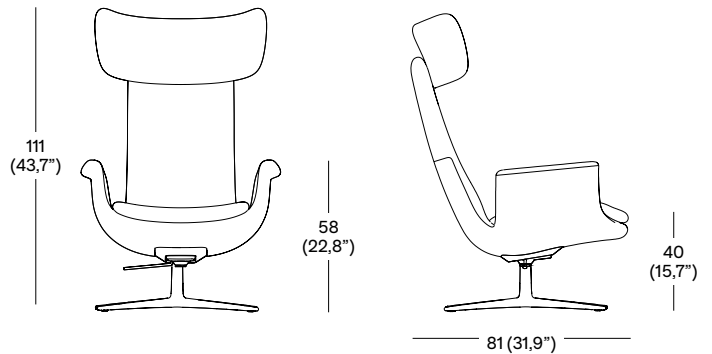

Inspired by one of mankind's greatest achievements, the latest member of the Explorer family is crafted with space-age curves and the highest precision.

BY JAIME HAYON



# Explorer cabinet

Jaime Hayon boasts one of the most glittering careers in contemporary design. He forged his identity as a designer at Benetton's Fabrica communications research centre, near Treviso, where he worked under Oliviero Toscani, first arriving in 1997. Soon after he was put in charge of the design department. He first worked with BD on the Mail Me project while at Fabrica, and in 2004, Hayon branched out on his own. The Explorer series comes straight from Hayon's own cosmos—his drawings—into light-hearted but elegant objects, finished in playful, beautiful glosses. This award-winning collection also includes a dining table, a number of side tables, and multiple vases, coming in an ever-expanding range of sizes and colour combinations.









# EXPLORER CABINET

BY JAIME HAYON

## FINISHES

Cupboards, doors and drawers in MDF. Gloss lacquered external finish and matte lacquered interior finish. Legs made from solid alder wood, gloss lacquer finish. Horizontal shelving and vertical bracket supports in MDF, gloss lacquer finish. Drawer units interior structure in MDF, matte lacquer finish.

## SIZE







<b>192 S</b> 192 x 50 x 62 cm (75,6 x 19,6 x 24,4 inch)	<b>240 S</b> 240 x 50 x 62 cm (94,5 x 19,6 x 24,4 inch)
<b>192 M</b> 192 x 50 x 82 cm (75,6 x 19,6 x 32,2 inch)	<b>240 M</b> 240 x 50 x 82 cm (94,5 x 19,6 x 32,2 inch)
<b>192 XL</b> 192 x 50 x 147 cm (75,6 x 19,6 x 57,9 inch)	<b>240 XL</b> 240 x 50 x 147 cm (94,5 x 19,6 x 57,9 inch)



Jaime Hayon



## COLORS

 White RAL 9016 Blue RAL 5000	 Blue RAL 5024 Creme NCS 1005-Y20R
 Black RAL 9005 Yellow RAL 1012	 Salmon RAL D2 040 50 30 Yellow RAL 1012
 Green RAL 6019 Green NCS 5540-G2OY	 Red RAL 3016 Grey NCS S 0502-G

### Cabinet explorer 192

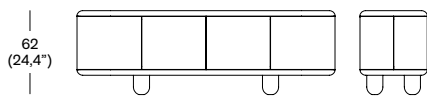

192 S

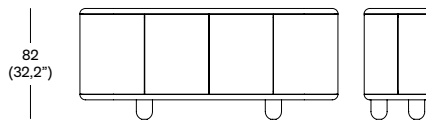

192 M

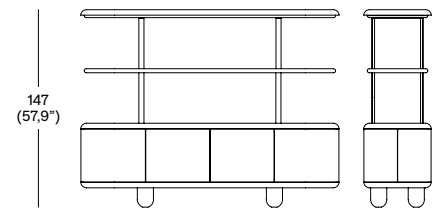

192 XL

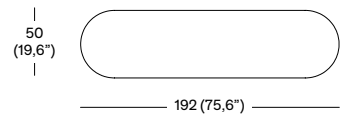
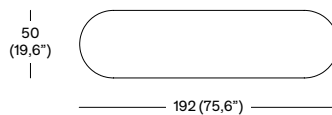
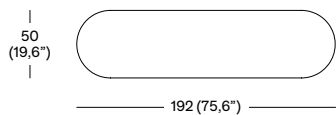

### Cabinet explorer 240

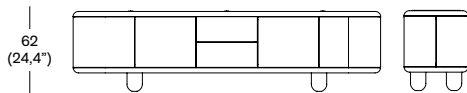

240 S

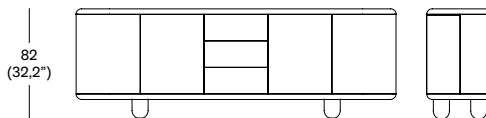

240 M

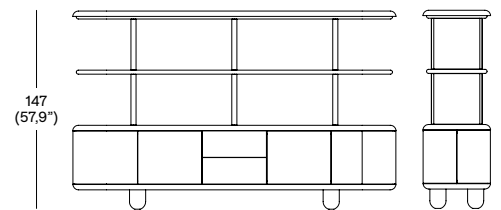

240 XL

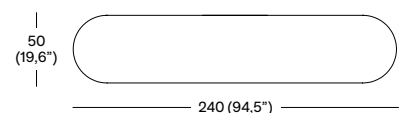
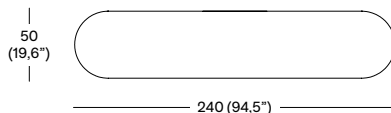
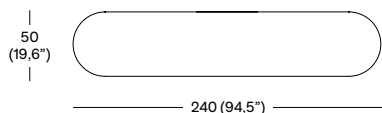

Introducing the latest Explorer table, with the same clean lines and bold hues, now in a new, lower model.

BY JAIME HAYON



# Explorer low table

For his own home, for many years, Hayon has designed pieces of furniture with simple, organic forms—in anticipation of children running around their edges, also just because they are elegant and beautiful. The latest table in the Explorer series uses the same clean curves and playful colours as its predecessors, now in a lower version, a perfect addition to any living space.



## EXPLORER LOW TABLE

BY JAIME HAYON

### FINISHES

Gloss lacquered external finish. Legs made from solid alder wood, gloss lacquer finish.

### SIZE

LOW 234  
234 x 50 x 23 cm  
92,1 x 19,7 x 9,1 inch

### LOW 184





184 x 50 x 23 cm  
72,4 x 19,7 x 9,1 inch



Jaime Hayon



### COLORS

- |   |   |
|---|---|
|  White RAL 9016       |  Blue RAL 5024           |
|  Blue RAL 5000        |  Creme NCS 1005-Y20R     |
|  Black RAL 9005       |  Salmon RAL D2 040 50 30 |
|  Yellow RAL 1012      |  Red RAL 3016            |
|  Green RAL 6019       |  Grey NCS S 0502-G       |
|  Green NCS 5540-G2OY |   |

### Explorer low table 234

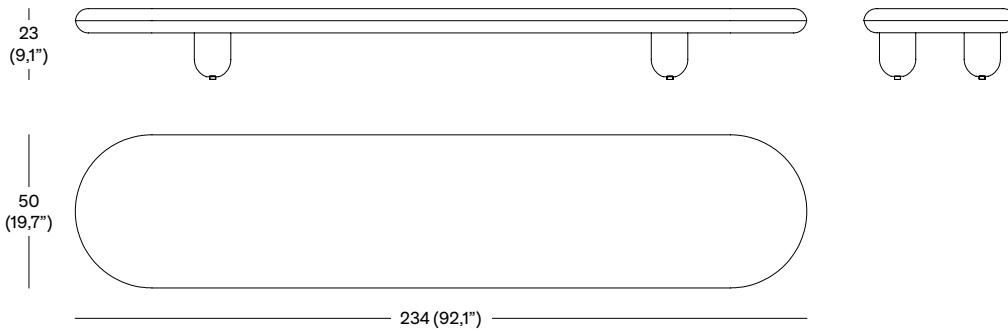

### Explorer low table 184

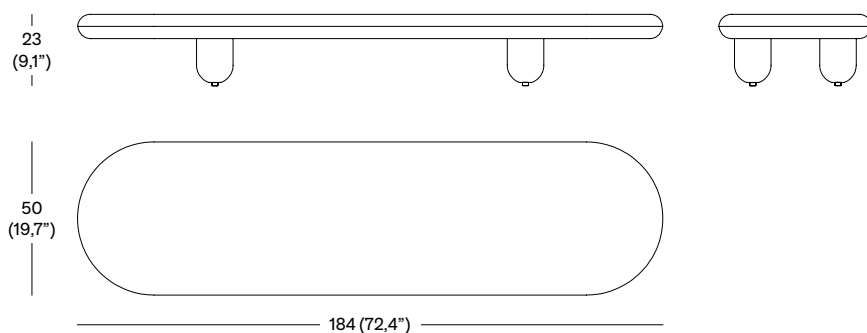

Our classic Gaulino chair is now accompanied  
by an entire collection of equally refined,  
well-defined furniture.

BY OSCAR TUSQUETS



# Gaulino family



Distinctive elements of the Gaulino chair run through this set of tables, combining clean, industrial processes with elegant, artisanal materials.

# Carlina table



Oscar Tusquets describes himself as an architect by training, a designer by adaptation, a painter by vocation, and a writer through the desire to make friends. Graduating from Barcelona's Escuela Técnica Superior de Arquitectura in 1965, Tusquets became a member of Studi Per. Together, they founded BD in 1972, and he set about designing furniture and objects, soon recognised by the Spanish National Design Award. The Gaulino Family was born in 1987, the first member of which was a chair, with a commission from an industry specialising in the production of baby cribs. This was Tusquets' first chair in wood, and is a comfortable, beautiful solution that respects the nobility of the material. On completing production, he named the chair after the two men who inspired it: Antoni Gaudí and Carlo Mollino. The Gaulino come to be an icon of Spanish design, now accompanied by a family of tables in a number of sizes and finishes.







# GAULINO FAMILY: CARLINA TABLES

BY OSCAR TUSQUETS

## FINISHES

Solid ash timber structure, stained black.  
1 cm thick tempered smoked glass top.

## SIZE

Carlina Dining (220)  
220 x 97 x 74 cm  
87 x 38,2 x 29,1 inch

Carlina Side Table (40)  
Ø40 x 50 cm  
15,6 x 19,7 inch

Carlina Dining (180)  
180 x 97 x 74 cm  
70,9 x 38,2 x 29,1 inch

Carlina Low (120)  
130 x 72 x 42 cm  
51,2 x 28,3 x 16,5 inch

Carlina Dining (120)  
Ø120 x 74 cm  
Ø47,2 x 29,1 inch



Oscar Tusquets

## COLORS

 Ash stained black



### Carlina Dining

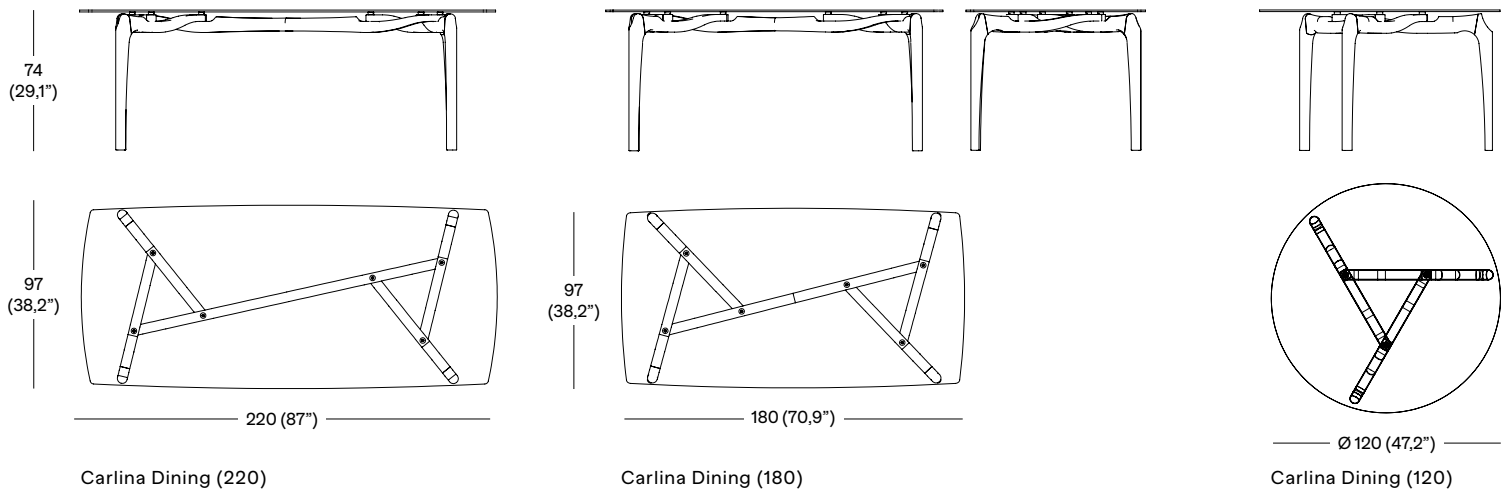

### Carlina Low

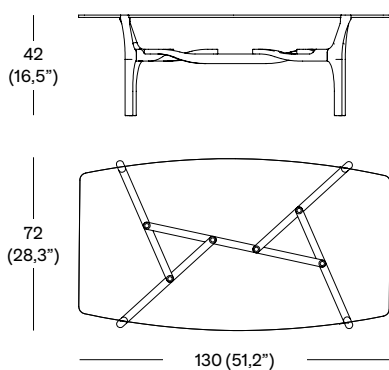

### Carlina Side table

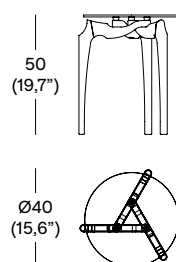



The original Gaulino chair is stripped down to its sculptural elements in this new, versatile stool.

# Gaulino stool

Following the success of the original Gaulino, Tusquets has long considered a model of the chair that is not tied to any particular setting, but free to move around the home with total ease. This stool is the latest iteration of the chair, of which multiple others exist: the Gaulino easy chair, a lower, wider version; and the Gaulinetta, an armless design ideal for tucking under the dining table. Each model has been through various prototypes and variations in order to meet a particular need, but this stool might be our most versatile Gaulino yet.



## GAULINO FAMILY: STOOL

BY OSCAR TUSQUETS

### FINISHES

Frame in natural varnished solid ash, ash stained black or coral red (RAL 3016).

Seat upholstered in natural hide, black hide or toasted hide.

### SIZE

50 x 46 cm  
(19,7" x 18,1" inch)



Oscar Tusquets

### COLORS



Ash stained black.  
Seat upholstered in black hide.



Natural varnished solid ash.  
Seat upholstered in natural hide.



Coral red open pore lacquered ash (RAL 3016).  
Seat upholstered in toasted hide.

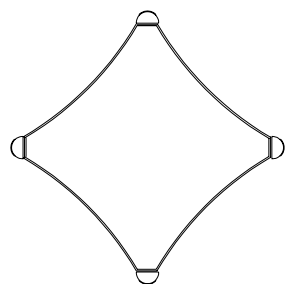
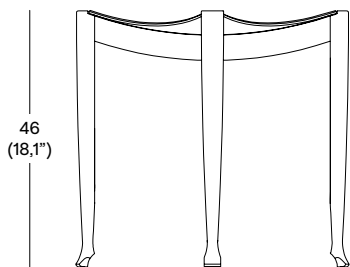

50 (19,7")

Classical principles of architecture inform this simple unit of shelves, bringing together horizontal and vertical elements in perfect harmony.

BY OSCAR TUSQUETS



Peristylo shelf



Columnata took its name from its underlying inspiration and a frequent reference in Tusquets' work, the column. Within this vertical structure, the horizontal shelves can be arranged in various formations—symmetrical and asymmetrical, wall-hung or free-standing. The final units are functional and refined, ideal for book-lovers and anyone who enjoys such compositional harmony.



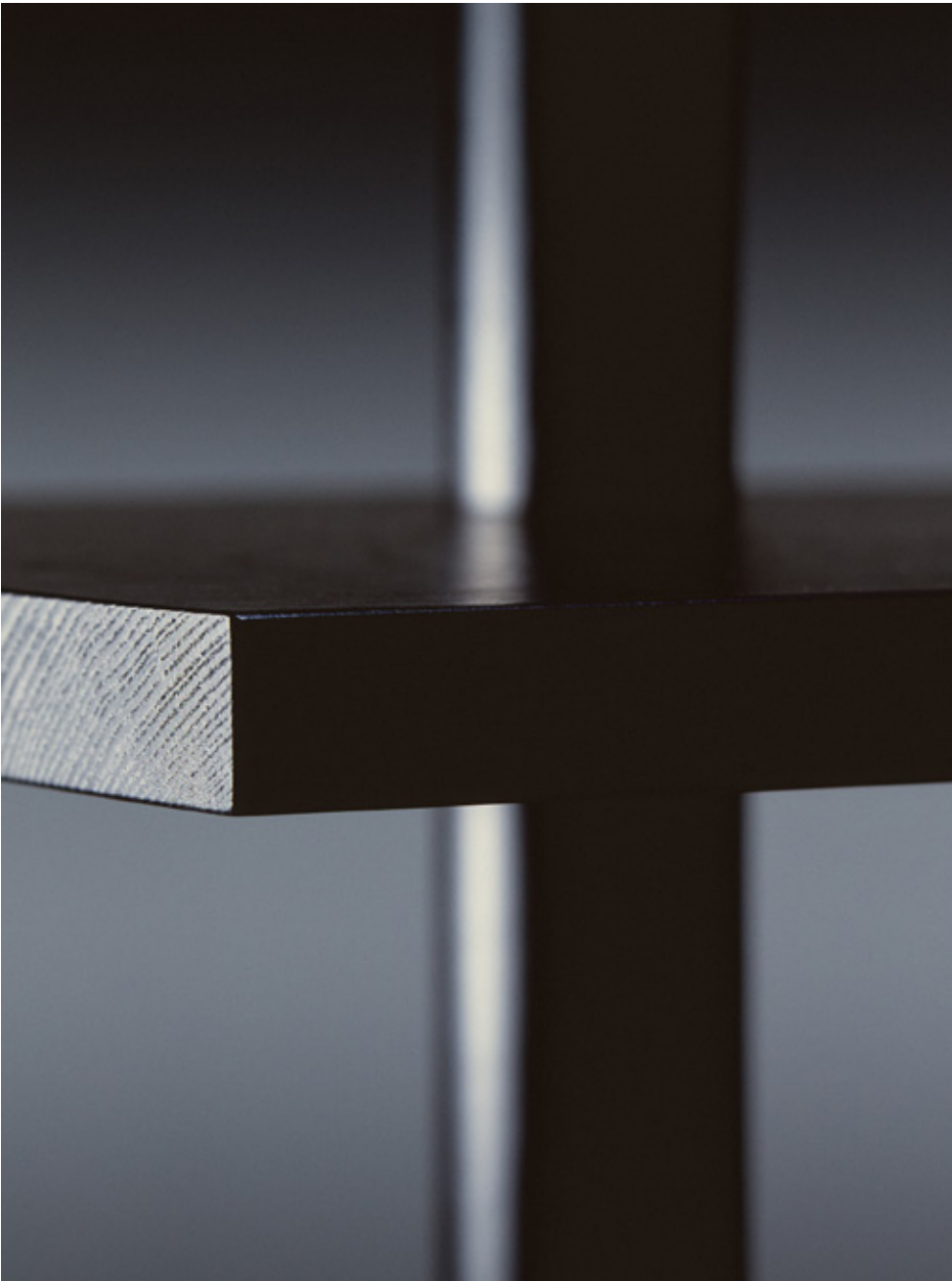

# PERISTYLO SHELF

BY OSCAR TUSQUETS

## FINISHES

Shelving and base in solid ash wood and turned vertical supports in stained black wood.

## SIZE

With baseboard  
92 x 40 x 218 cm  
36,2 x 15,7 x 85,8 inch

Without baseboard  
92 x 40 x 211 cm  
36,2 x 15,7 x 83 inch



Oscar Tusquets

## COLORS

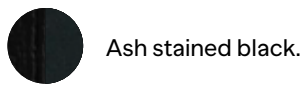

With baseboard

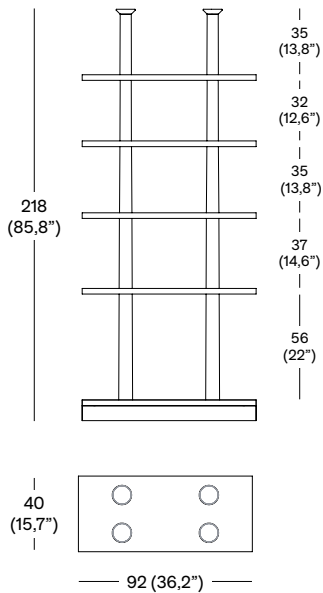

Without baseboard

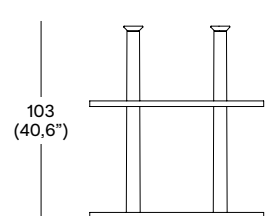
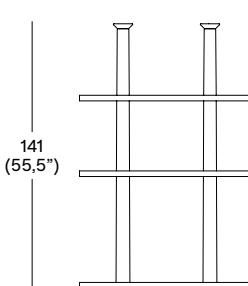
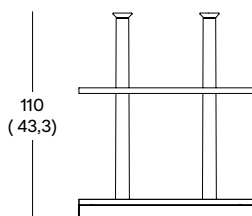
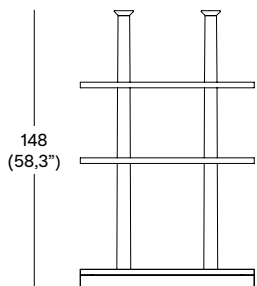
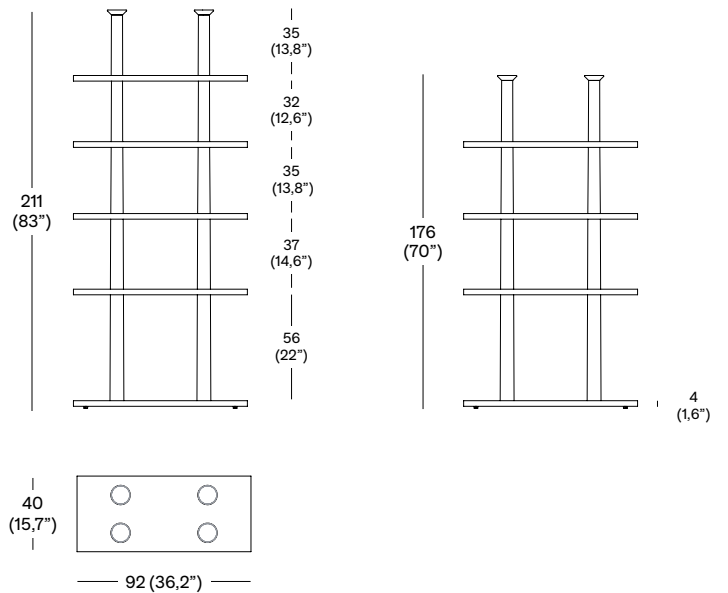

In a Surrealist play of semiotics, melted candle wax forms the candelabra itself, inspired by two of the movement's greatest figureheads.

BY OSCAR TUSQUETS



**Alberto candleholder**

In this design, Tusquets was inspired by one of Dalí's approaches: a softened vision of a rigid object. Candle wax was melted, solidified, and cast in bronze—originally left with its natural finish but later glazed in an off-white shade, such that when the candle burns and drips, the wax blends with the candelabra itself. Despite the influence of Dalí, the result looked somewhat like a sculpture by Alberto Giacometti, and Tusquets renamed the object accordingly.



# ALBERTO CANDLEHOLDER

BY OSCAR TUSQUETS

## FINISHES

Cast iron painted in matte white.  
Available in two heights.

## SIZE

High candleholder  
12 x 8 x 28 cm  
4,7 x 3,1 x 11 inch

Low candleholder  
10 x 6 x 20 cm  
3,9 x 2,4 x 7,9 inch



Oscar Tusquets

## COLORS



Cast brass painted in matt white.

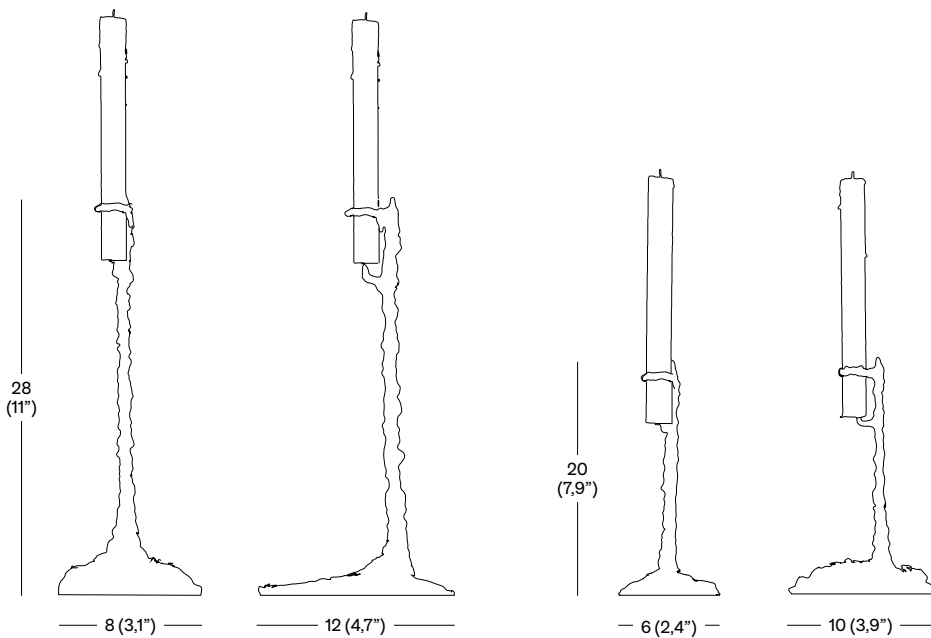

Over a century ago this sculptural bottle was designed in glass. Now, a new, weightier version is reimagined in ceramic.

BY JOSEP MARIA JUJOL



Casa de Familia bottle

Josep Maria Jujol (1879–1949) is one of the greatest yet least known figures in Catalan architecture. He embraced a number of artistic disciplines with the same impressive imagination; he was an architect, a painter, sculptor, and graphic artist, among other things, and was Gaudí's closest and keenest collaborator. After working with the maestro, Jujol experimented with many styles to establish his own creative universe, far removed from the conventions of the time. The Casa de Familia bottle, designed in 1912 for the orphanage of the same name, is a simple and humble piece that demonstrates his artistic ability. Only one photograph of the original model still exists, cleverly taken in front of two mirrors to show the work in full, now faithfully reproduced by BD and made to last for centuries to come.







## CASA DE FAMILIA BOTTLE

BY JOSEP MARIA JUJOL

### FINISHES

Aa new and improved more durable version in ceramic. Its tactile relief and tapered silhouette are more evident.

### SIZE

14 x 28 cm  
5,5 x 11 inch  
Capacity 1,2 L

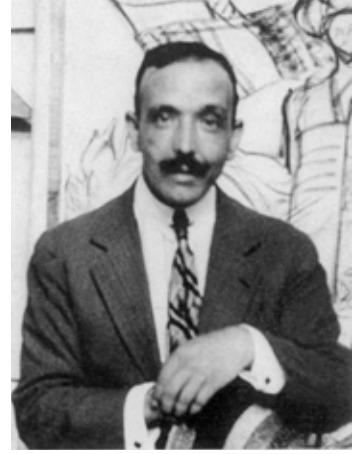

Josep Maria Jujol

### COLORS



Cast brass painted in matt white.

+

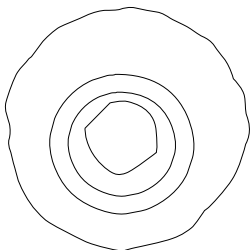
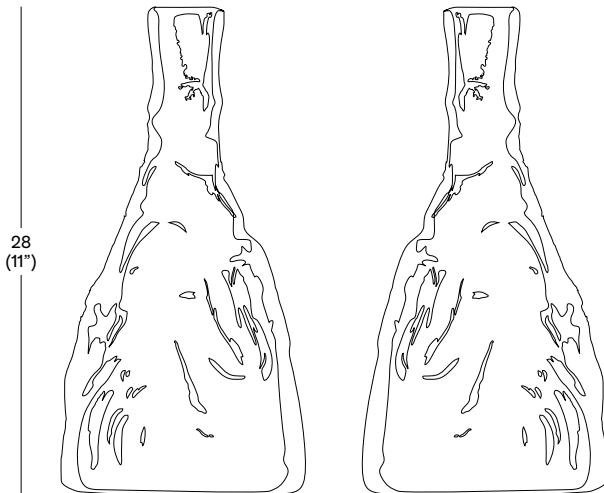

14 (5,5")

Age-old coffee-making traditions from the Emirates are given new life in this collection of stackable pots and cups.

BY ALFREDO HÄBERLI



# Doobide

50th ANNIVERSARY EDITION

Alfredo Häberli is an award-winning designer hailing from Argentina. His family was Swiss and their background was in the restaurant business—a fact which would later inform a number of Häberli's commissions. In 1977 they moved back to Switzerland, where he graduated as an industrial designer from the Höhere Schule für Gestaltung, Zürich. He soon founded his own studio, and success followed quickly. Häberli originally designed the Doobide on the occasion of The World Expo of Dubai in 2021 for BD. He was inspired by the Arab world's coffee-drinking rituals—as a ceremony, as a symbol of generosity, and representing an important aspect of cordial hospitality. The crockery was designed without handles, instead held just by the neck of the vessel, and was decorated in playful colours. For BD's 50th anniversary, Häberli has created a limited edition of 50 numbered sets, decorated with varying hand-drawn motifs.





## DOOBIDE

### FINISHES

A Limited edition of 50 numbered crockery sets, each one composed of a teapot and 6 teacups. The pieces are made out of dyed porcelain and painted by hand in platinum.

### SIZE

Teapot  
16 x h. 18 cm  
6,3 x 7,1 inch

Teacups  
5,6 x h. 6,5 cm  
2,6 x 2,2 inch

BY ALFREDO HÄBERLI



Alfredo Häberli

### COLOR

-  Green
-  Beige
-  Flesh
-  Grey
-  Blue

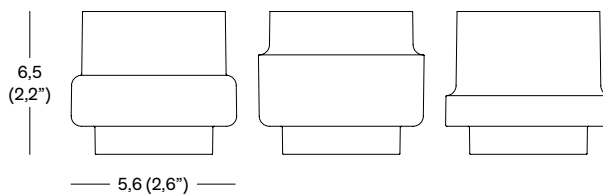
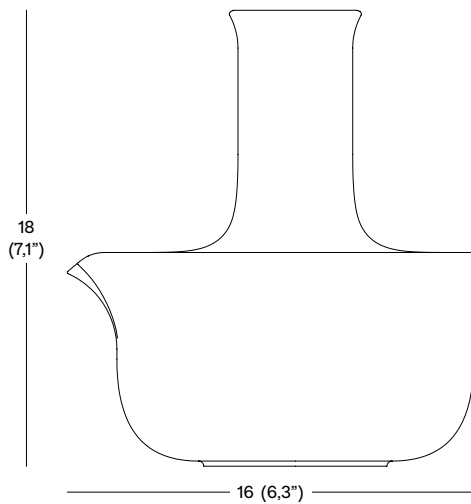

For further information

BD Barcelona Design

Ramon Turró 126,

08005 Barcelona (Spain)

+34 934 586 909

[bd@bdbarcelona.com](mailto:bd@bdbarcelona.com)

[bdbarcelona.com](http://bdbarcelona.com)

