

THE LIFE SIZE
COLLECTION



CANDELABRO

MARIVÍ CALVO
SUSPENSION

TECHNICAL DATA
SEE PG. **566**



CLBO 15 LED-20 JMM shop, Valencia, Spain.

CANDELABRO

SUSPENSION

Ref. CLBO 15 LED

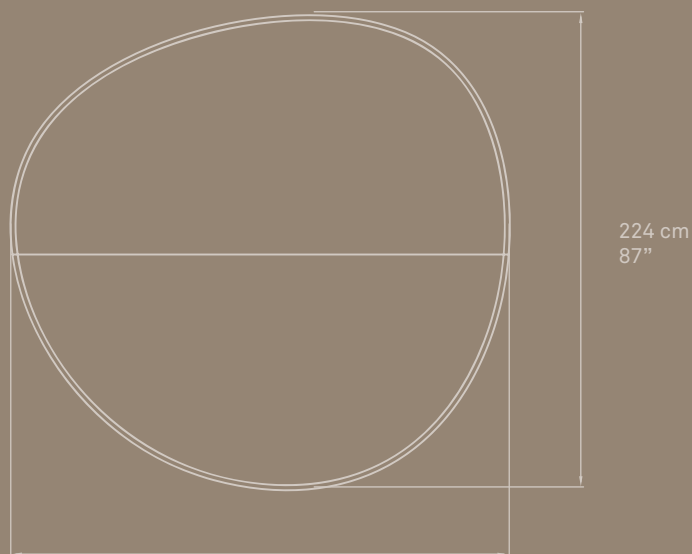
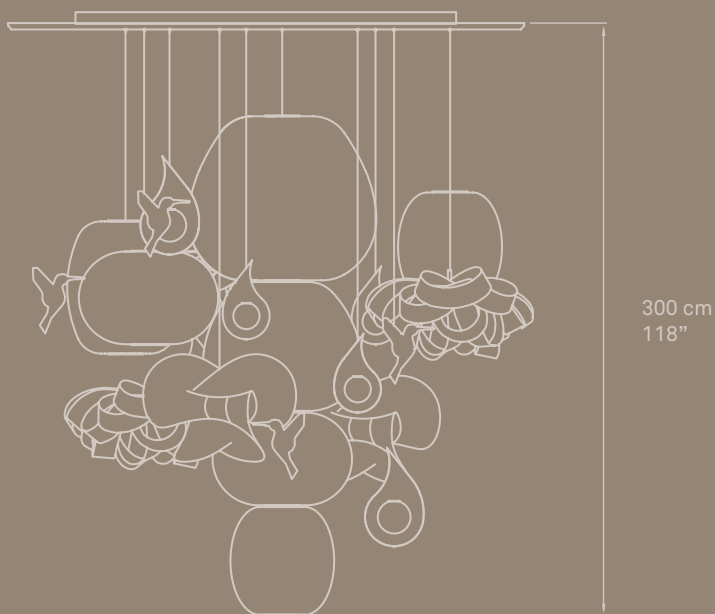

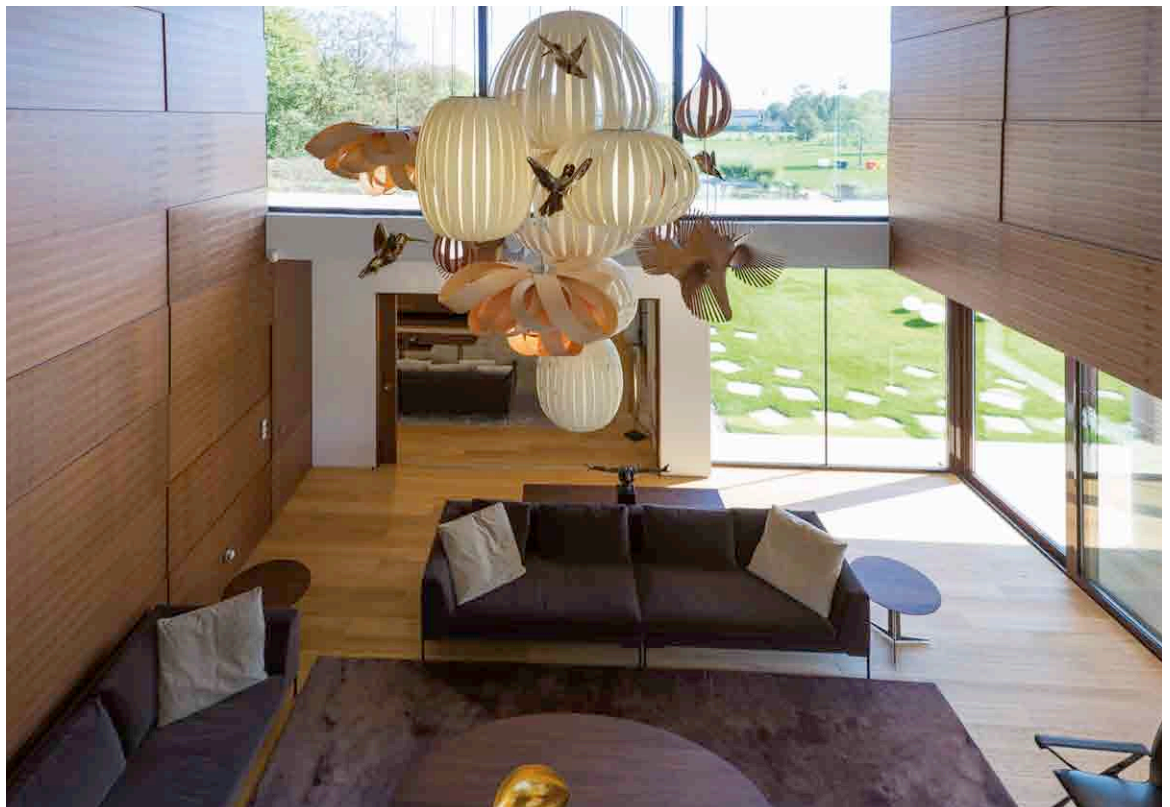
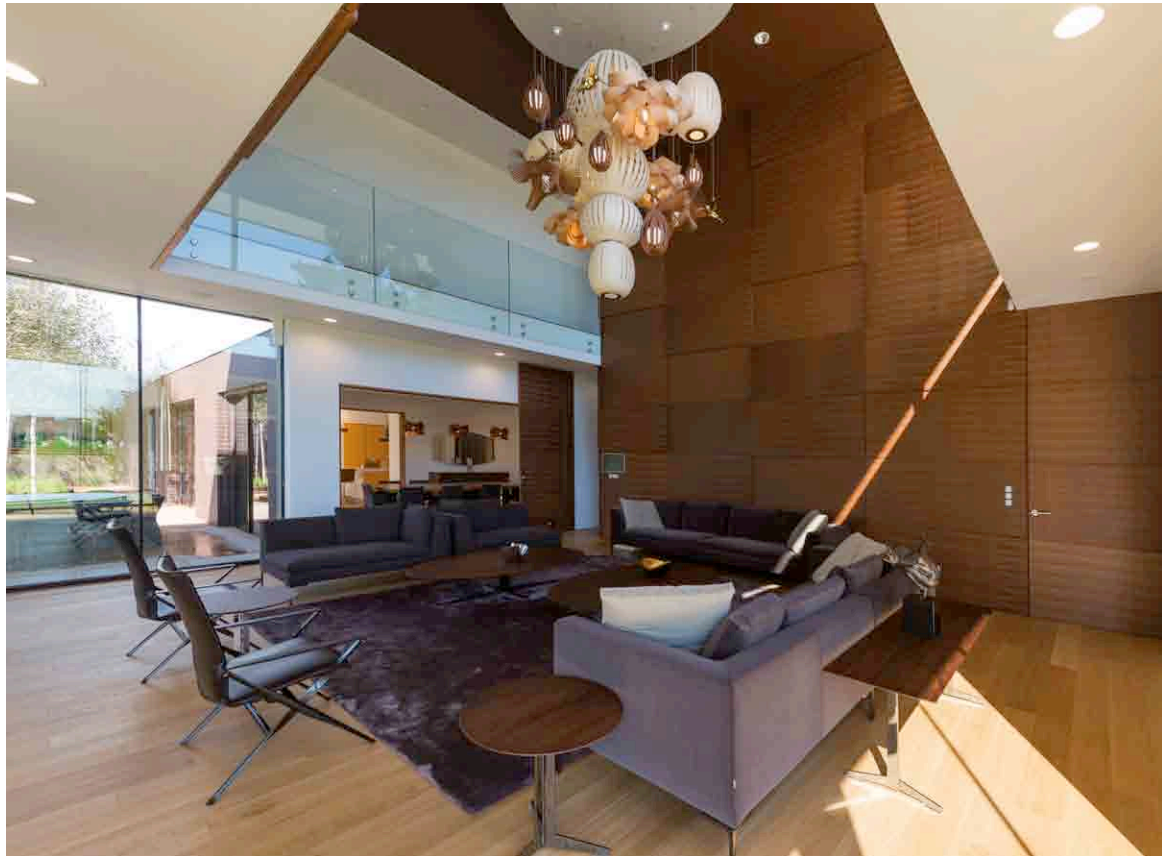

CLB015 LED-20/22

Project:
Villa π

Location:
Osijek, Croatia

Architects:
Oliver Grigic



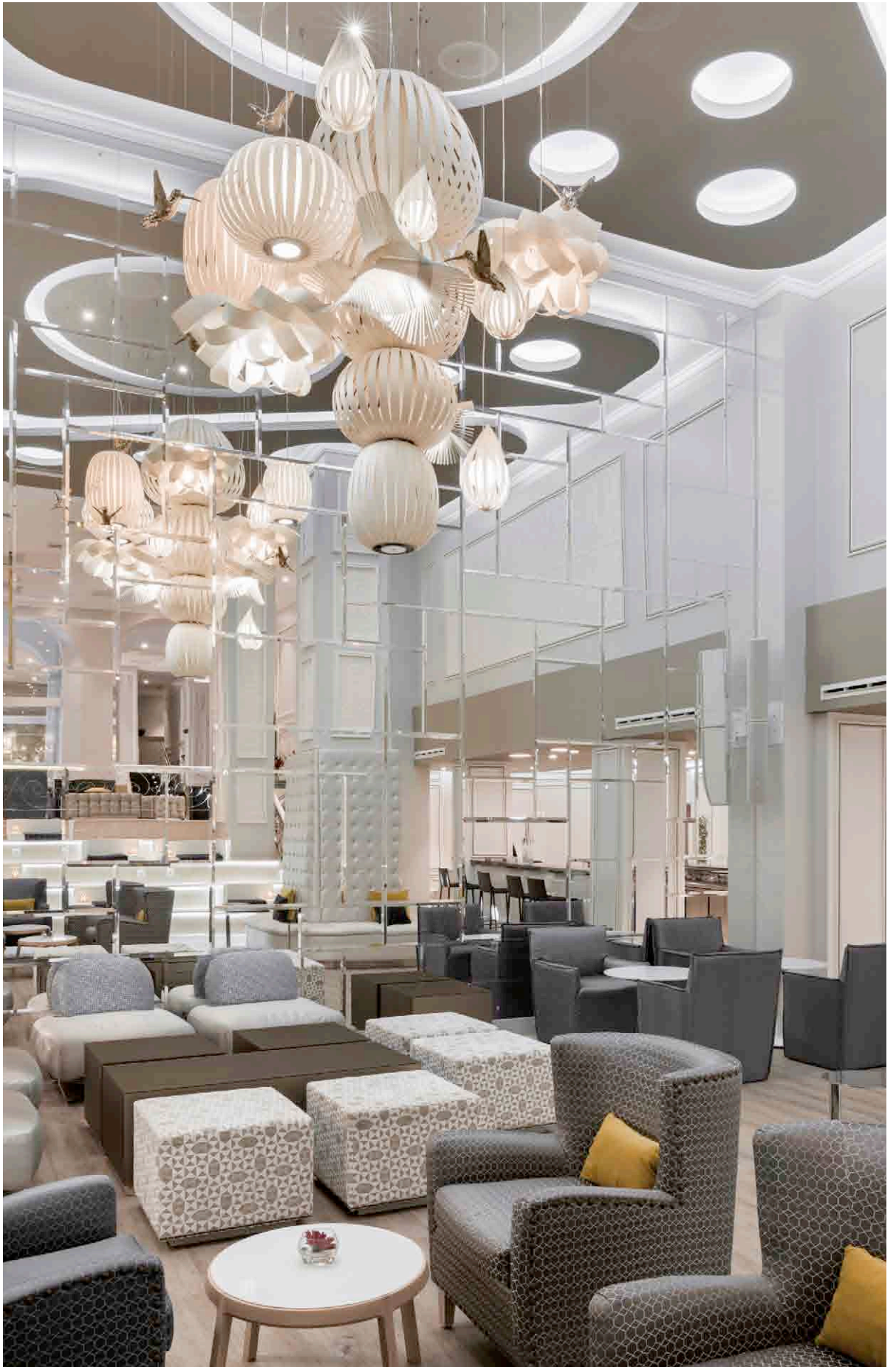

CLBO 15 LED-20

Project:
NH Abascal Hotel

Location:
Madrid

Architects:
Proffetional





ELEPHANT
ISIDRO FERRER
FLOOR

TECHNICAL DATA
SEE PG. **566**



ELEPHANT FLOOR

Ref. ELE LS LED

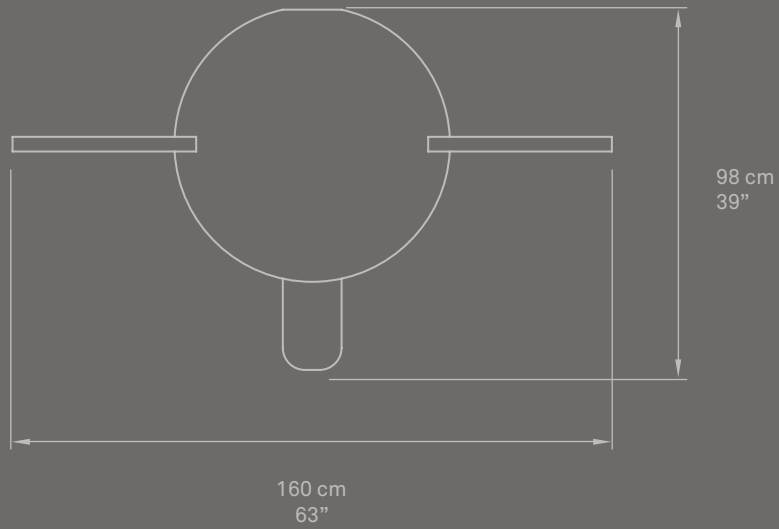
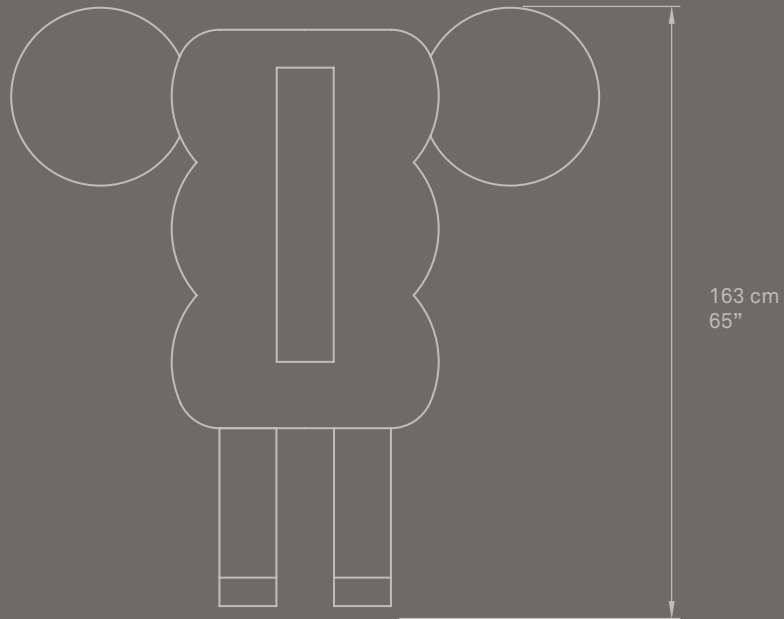



ELELS LED Palau de Casavells. Art, Antiques, Design, Architecture. Girona, Spain.





ELE LS LED





ELE LS LED



ELELS LED

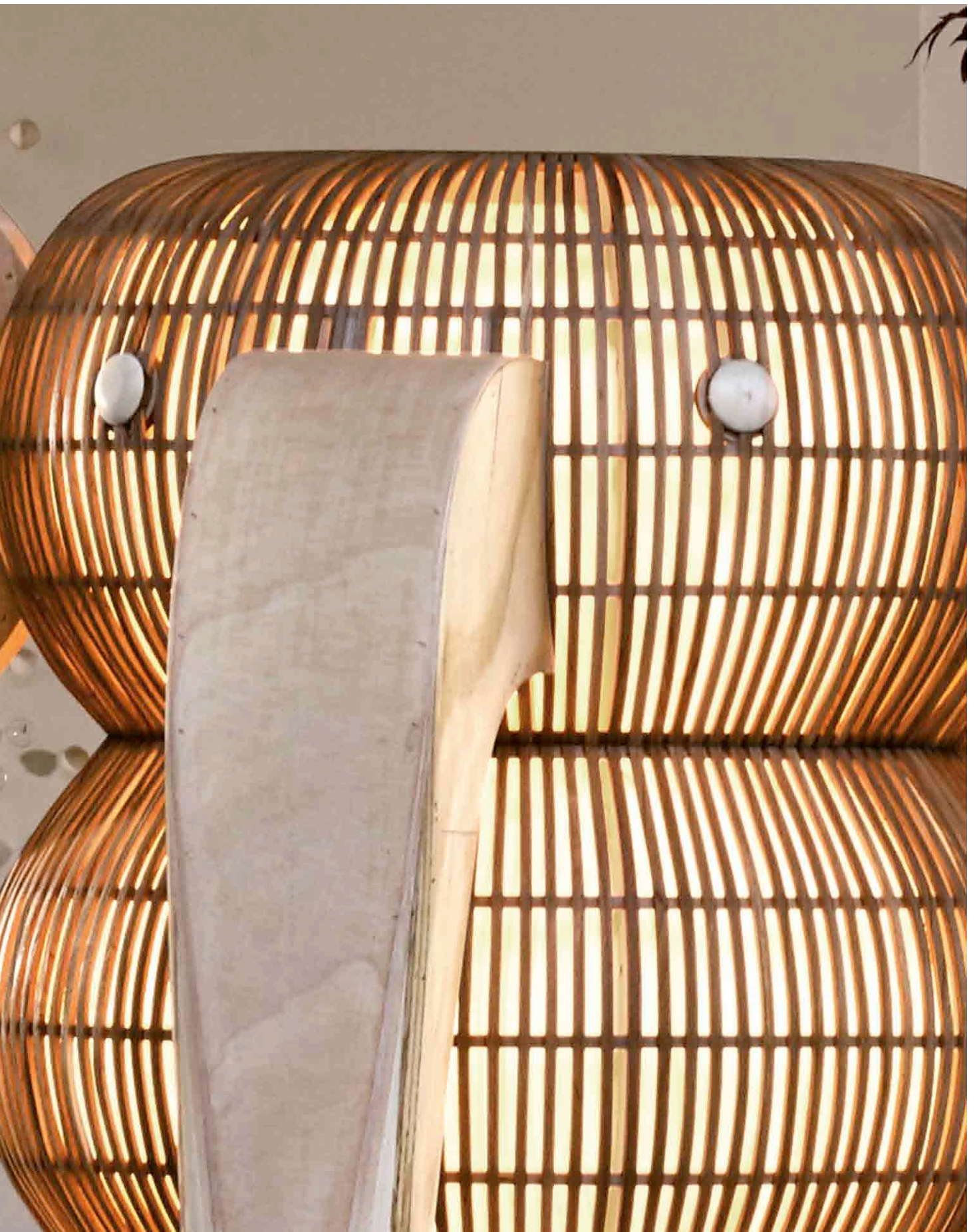



FISH

ISIDRO FERRER
FLOOR

TECHNICAL DATA
SEE PG. **567**



FISH FLOOR

Ref. FSH LS LED

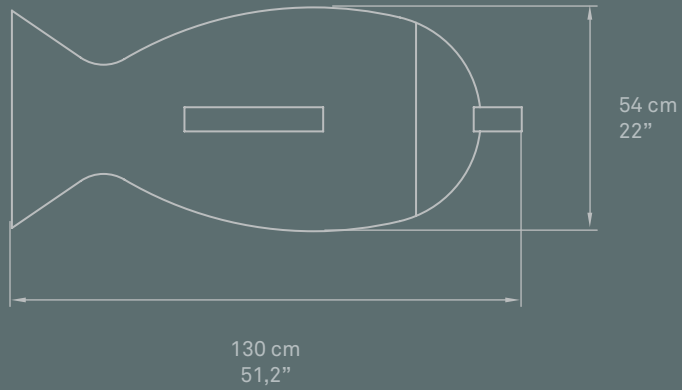
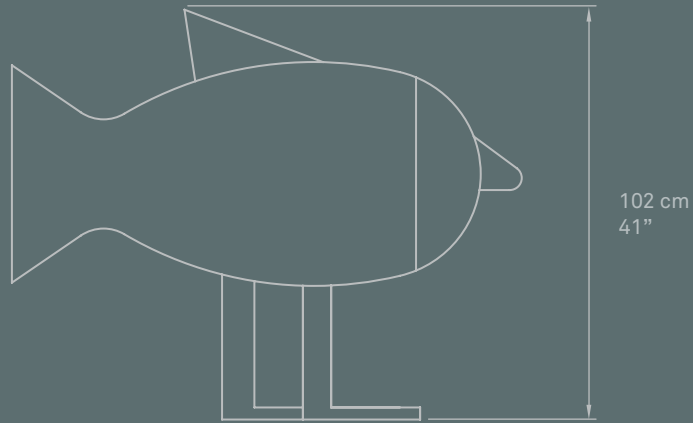



FSH LS LED Palau de Casavells. Art, Antiques, Design, Architecture. Girona, Spain.





FSH LS LED



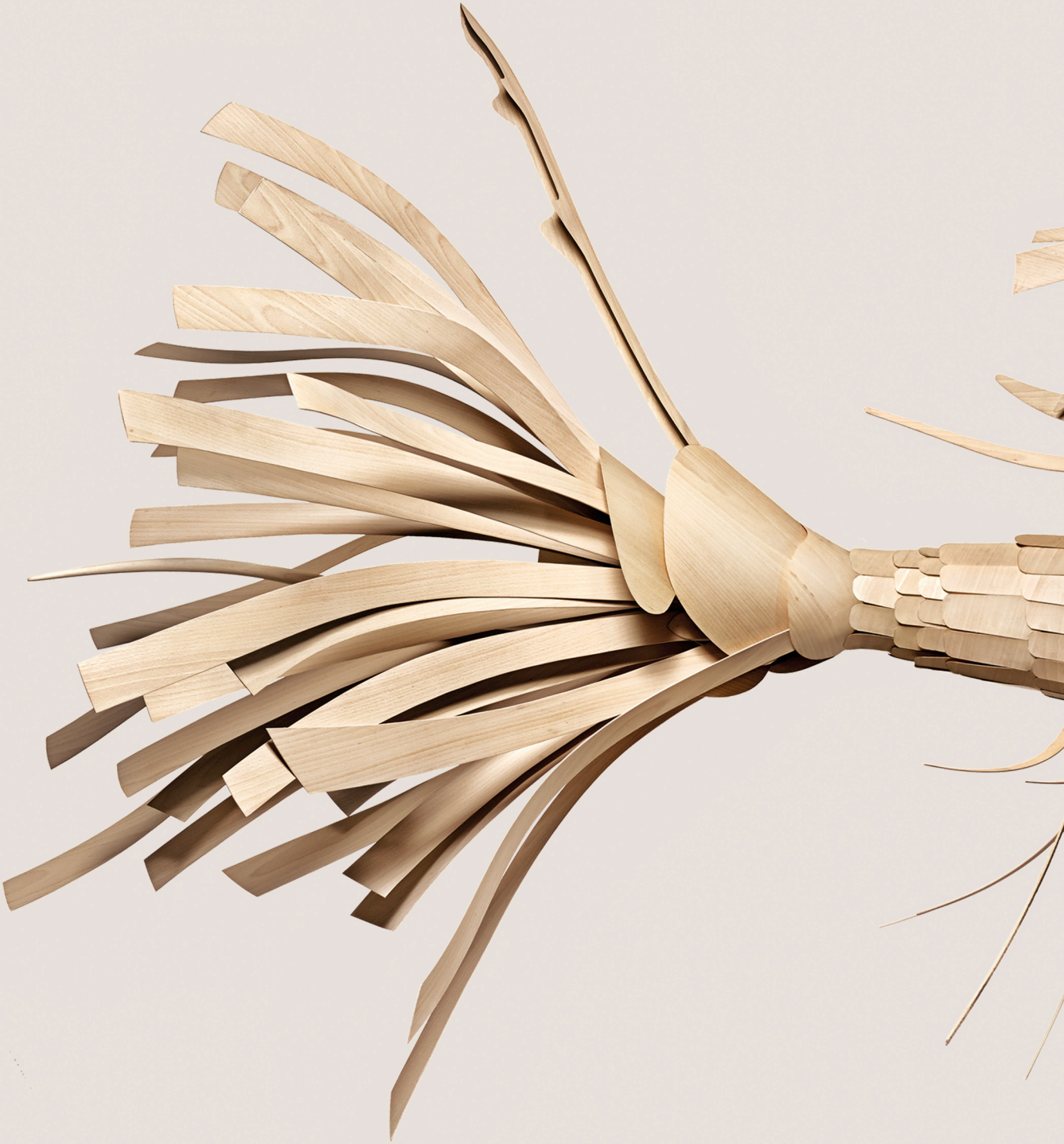

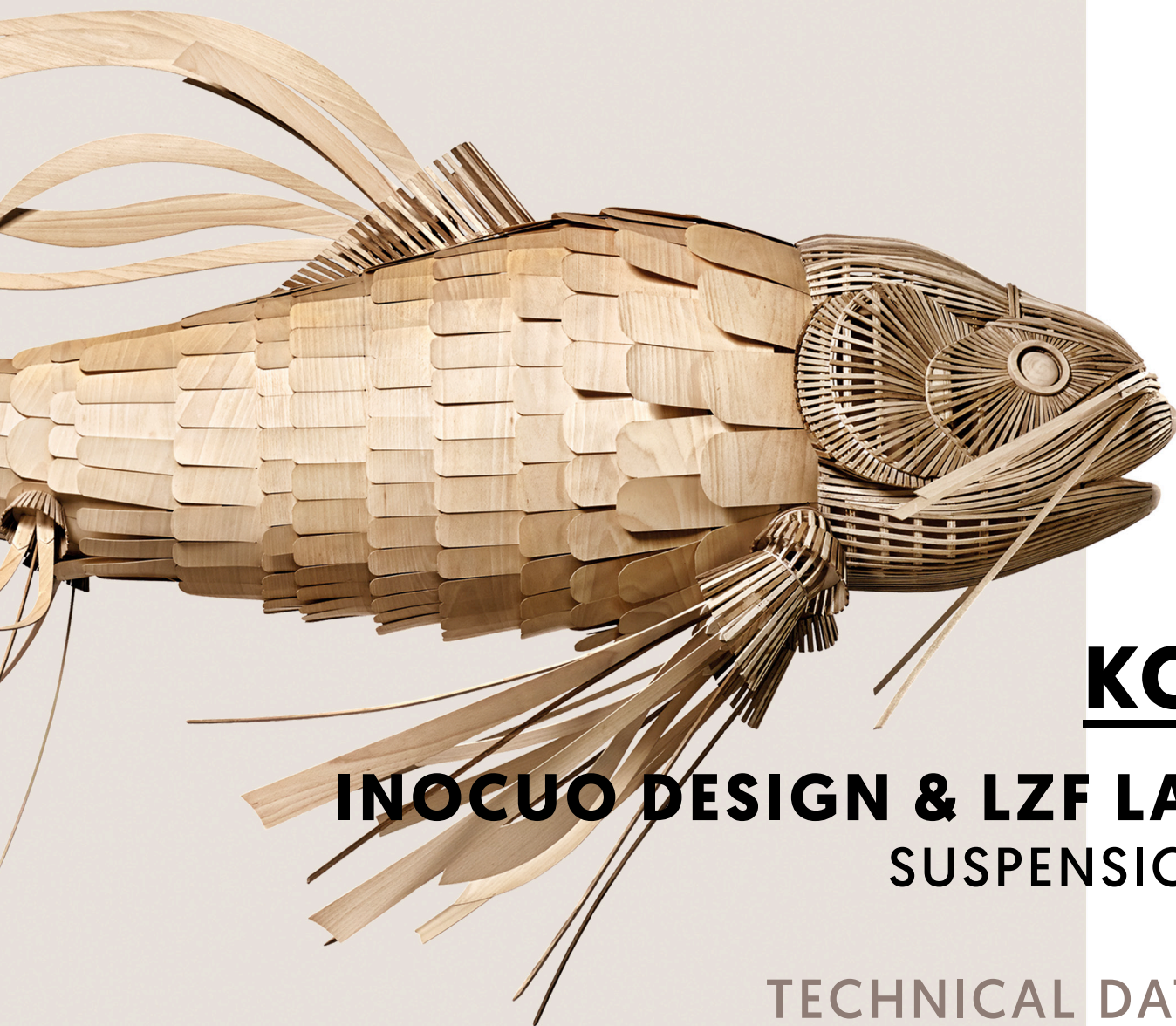

KOI

INOCUO DESIGN & LZF LAB
SUSPENSION

TECHNICAL DATA
SEE PG. **567**



KOI SUSPENSION

Ref. KOI LS LED

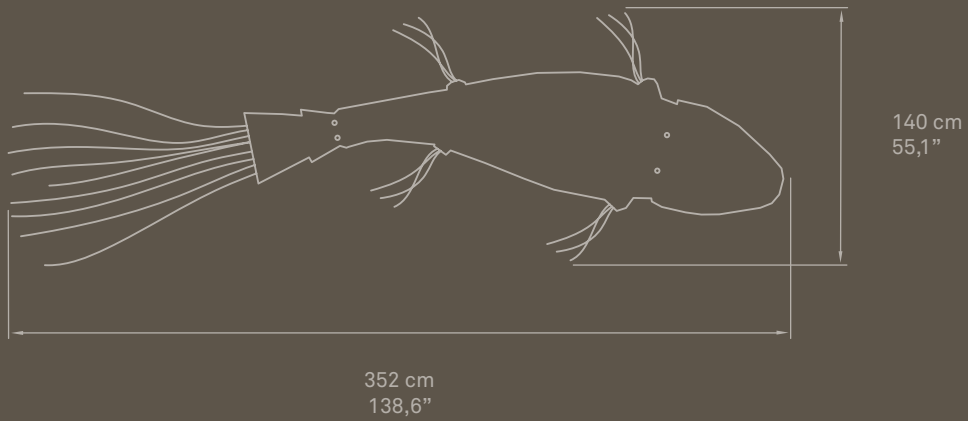
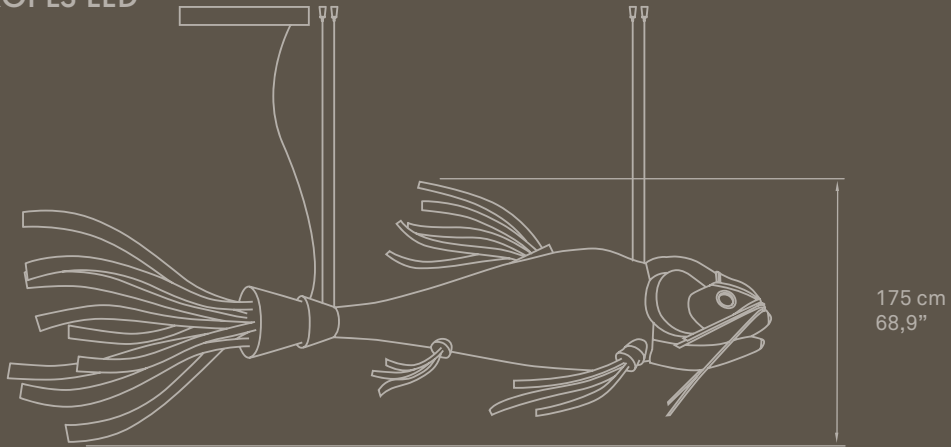



KOILS LED-20



KOI LS LED-20



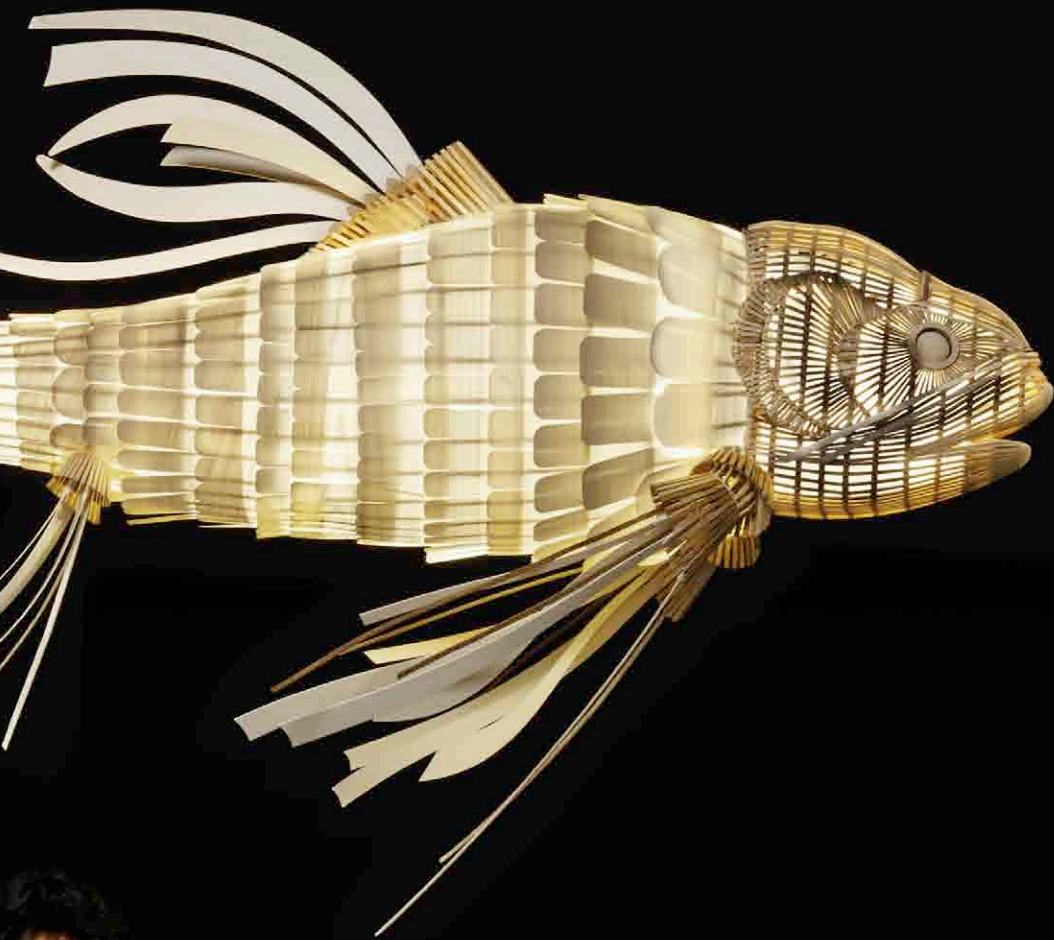









Photographic reproductions of our veneers can only be taken as a guideline to the actual colour of the veneers. Please use real colour swatches for tone matching as the wood's colour changes dramatically depending on the light source and the colour temperature of the bulbs. LZF will not accept any returns based on selections made using photographic reproductions.

Recommendations:

Avoid direct sunlight or strong indirect sunlight on the fixture. Exposure to the sun can change the colour of the wood over time. Please read all our instructions and recommendations on the use and care of our fixtures.

WOOD SHADE FINISHES

Timberlite[®]

The dramatic effect of light passing through the wood veneer is the essence and hallmark of LZF. This important feature would not be possible without the application of our patented process in treating the raw natural veneer: the Timberlite[®] system.

This system, the result of LZF's research & development work, allows us to work with an extremely flexible, yet very resistant veneer, which can take on many shapes without breaking. In addition to all our veneers being FSC certified, thanks to the treatment, the wood used to fabricate our lamps maintains its natural qualities, adopting different nuances and hues over time.



The mark of
responsible forestry

NATURAL TIMBER VENEER

SWITCHED ON



21 Cherry



22 Beech

COLOURED NATURAL TIMBER VENEER



20 Ivory white



28 Blue



24 Yellow



29 Grey



25 Orange



30 Turquoise



26 Red



31 Chocolate

Please only use these reproductions as a guide. Use LZF wood swatches to see the spectacular real effect of the illuminated veneers.



32 Pink

NATURAL TIMBER VENEER

SWITCHED OFF



21 Cherry



22 Beech

COLOURED NATURAL TIMBER VENEER



20 Ivory white



28 Blue



24 Yellow



29 Grey



25 Orange



30 Turquoise



26 Red



31 Chocolate

Please only use these reproductions as a guide. Use LZP wood swatches to see the spectacular real effect of the illuminated veneers.



32 Pink