



A		18
B		18
C		04
D		18
E		06
F		24
G		12
H		04
I		60
J		36
K		04

L		02
M		02
N		04
O		06 Peças
P		04
Q		04
R		06
S		01
T		07
U		08

Utilizar a régua abaixo para medir os componentes.



Ref. 14550

Nº Peça	Nome da Peça	Qtde
1	Tampo	01
2	Lateral Esquerda	01
3	Lateral Direita	01
4	Fundo	01
5	Traseiro Estreito	02
6	Traseiro Largo	01
7	Pé Montado	02
8	Frente de Gaveta	03
9	Lateral de Gaveta	06
10	Fundo de Gaveta	03
11	Traseiro de Gaveta	03
12	Travessa de Gaveta	03
13	Divisória	01
14	Prateleira	01
15	Porta	01
16	Travessa Lateral Pé	02

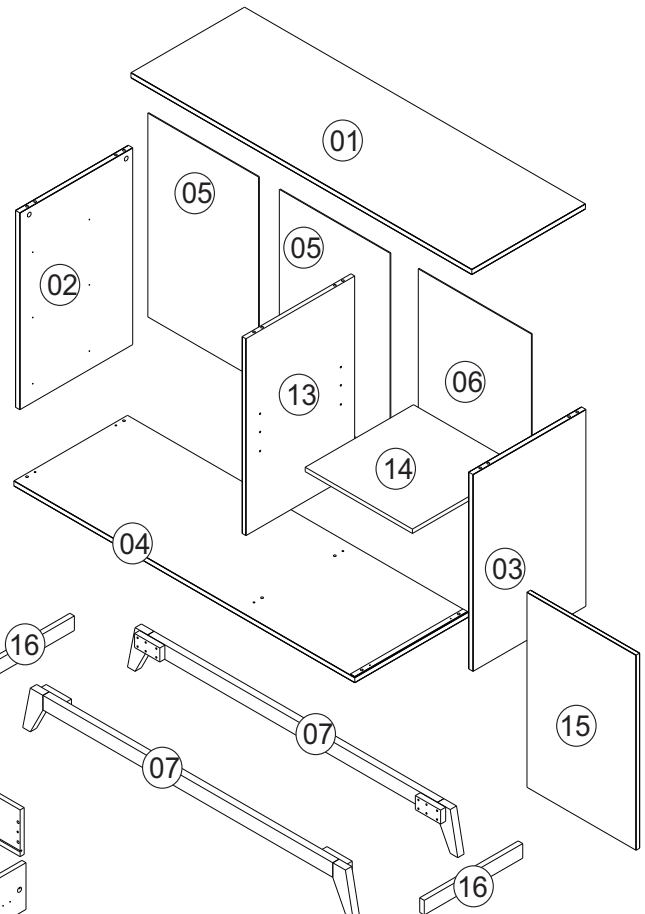

Ferramentas não fornecidas, mas necessárias para a



Martelo



Chave Phillips



Chave Fenda



Furadeira Broca Ø 5mm

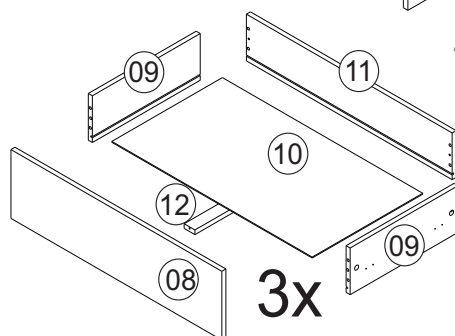

01

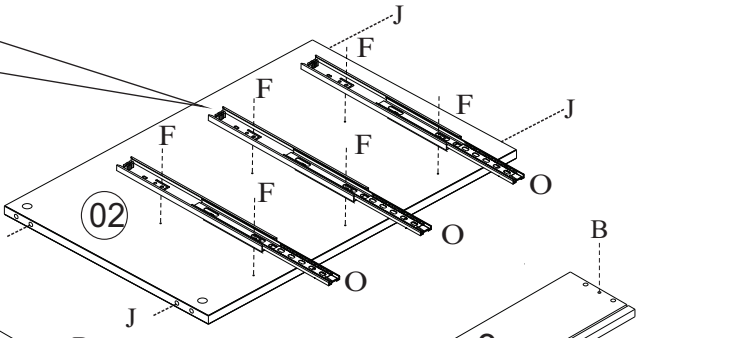
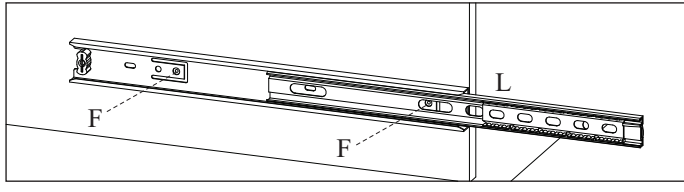
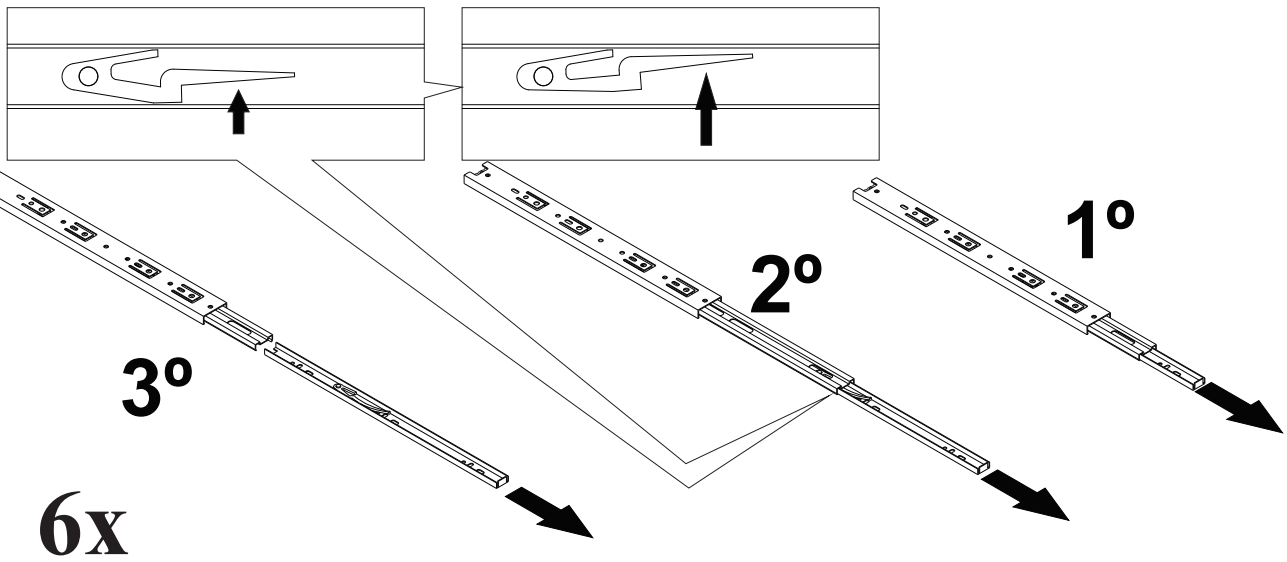

02

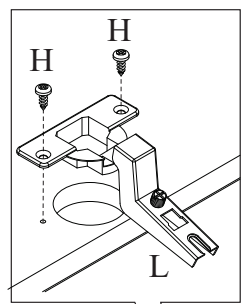
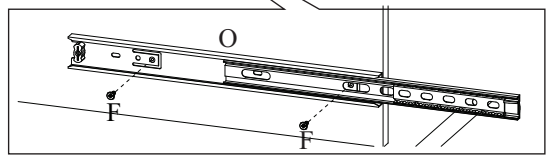
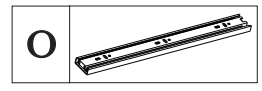
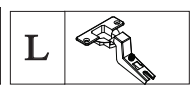
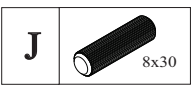
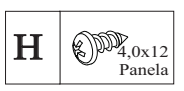
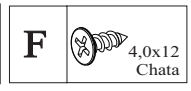
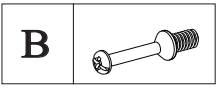
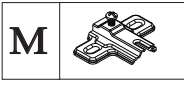
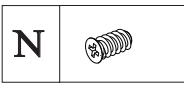
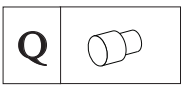
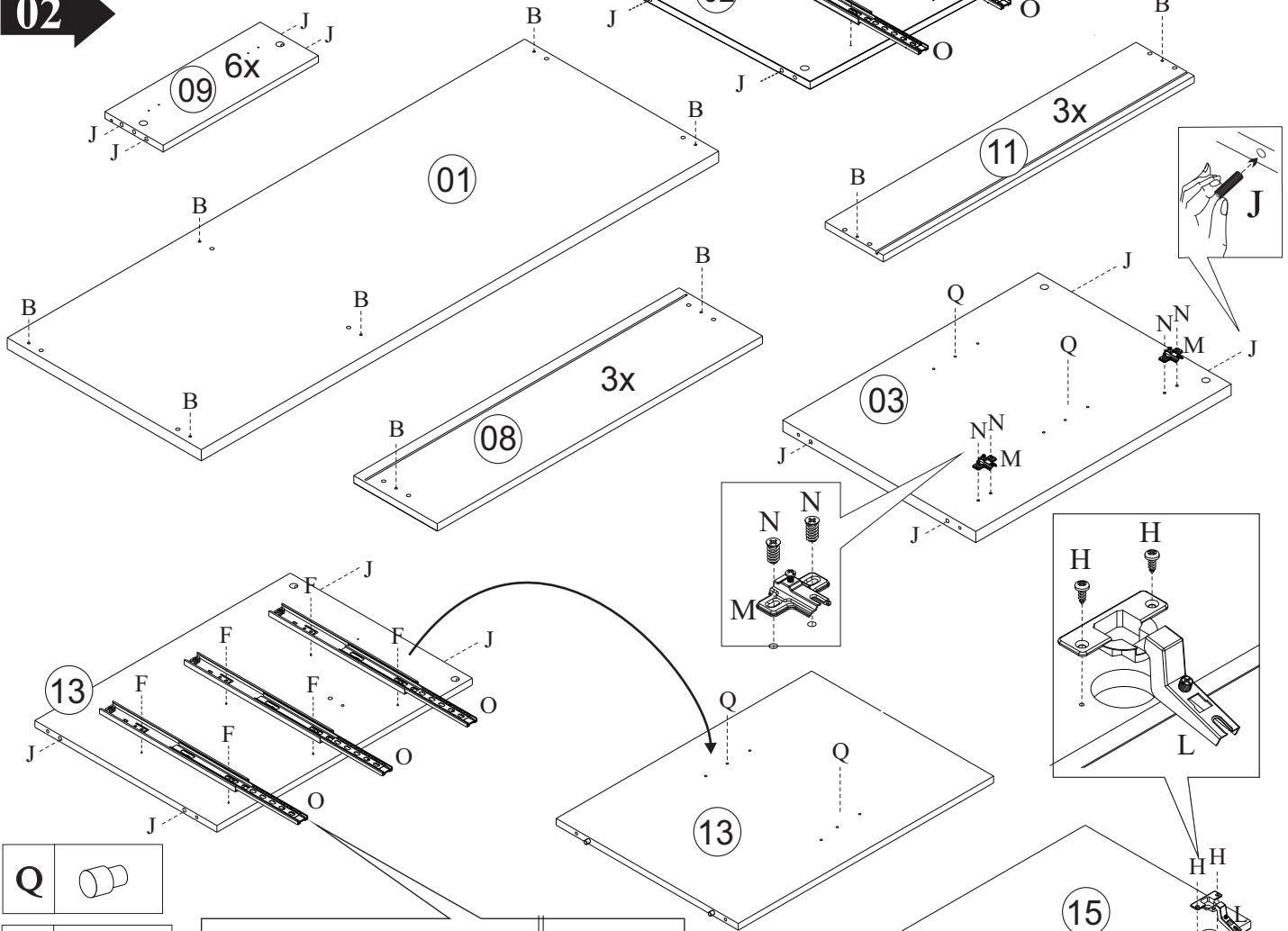

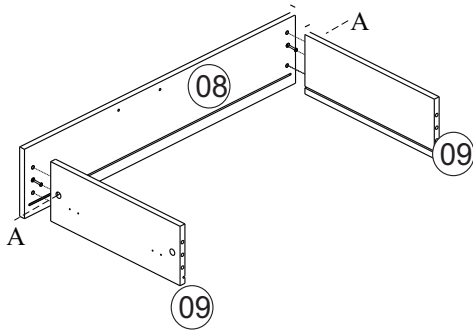
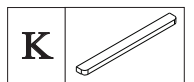
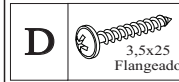
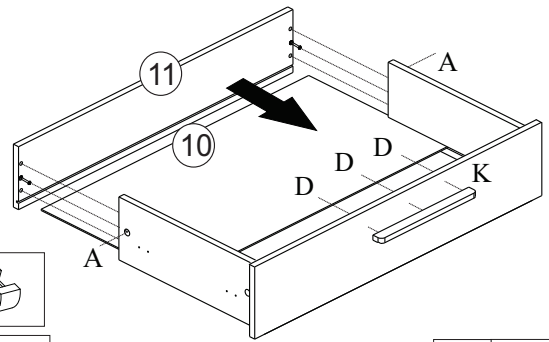
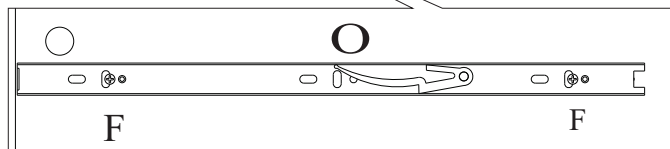
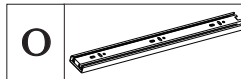
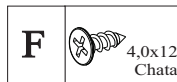
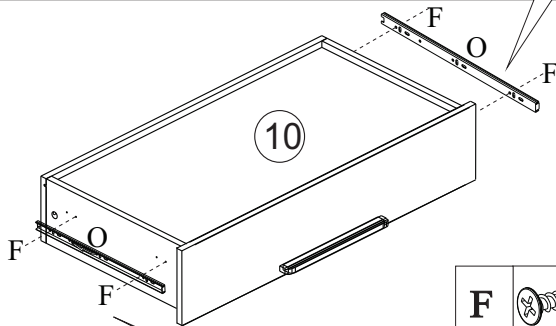
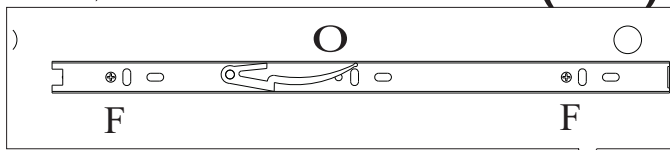
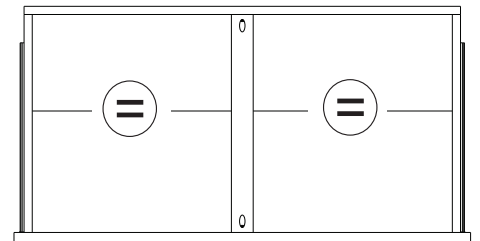
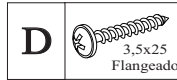
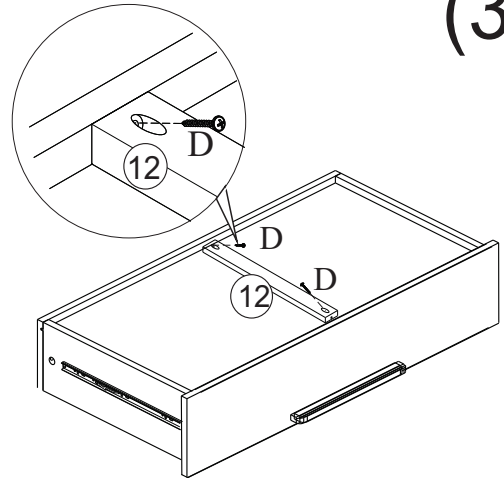
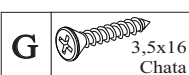
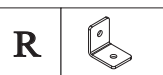
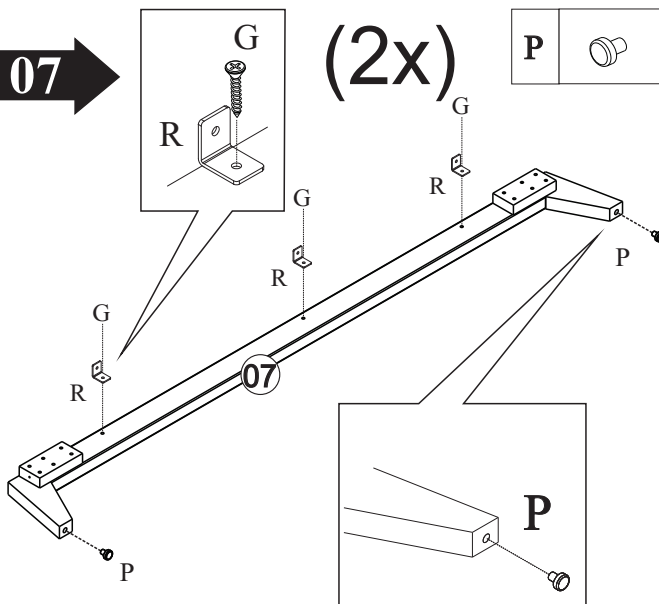
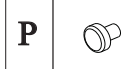
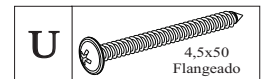
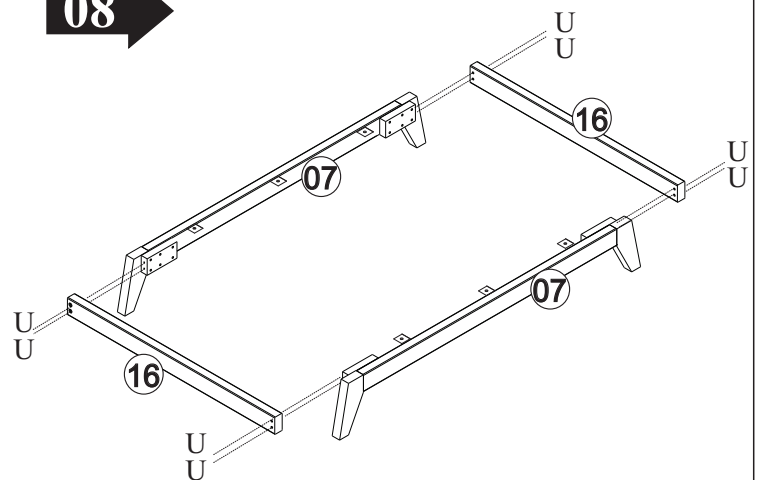
03**(3x)****04****Fazer furos para puxador utilizando broca ø5****(3x)****05****(3x)****06****(3x)****07****(2x)****08**

09

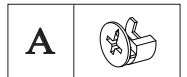
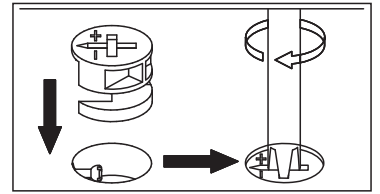
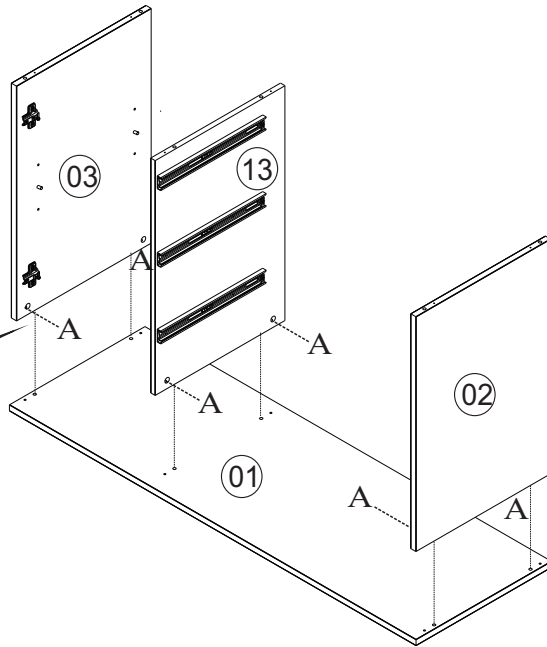
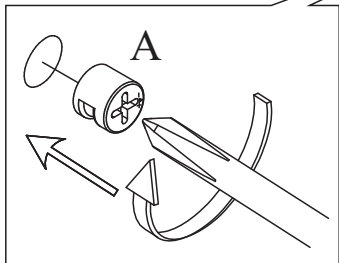

10

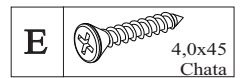
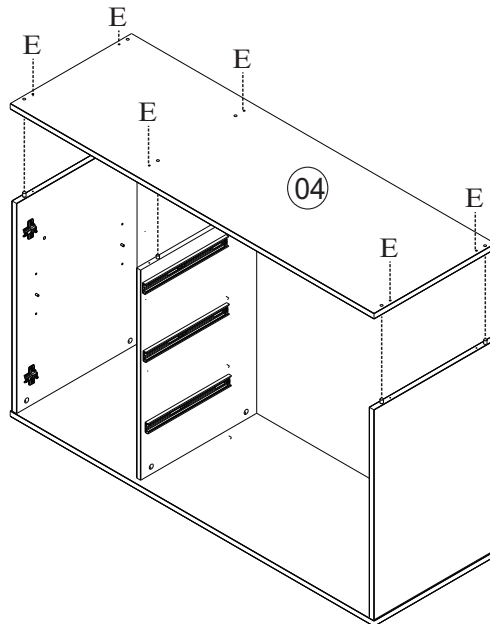

11

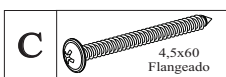
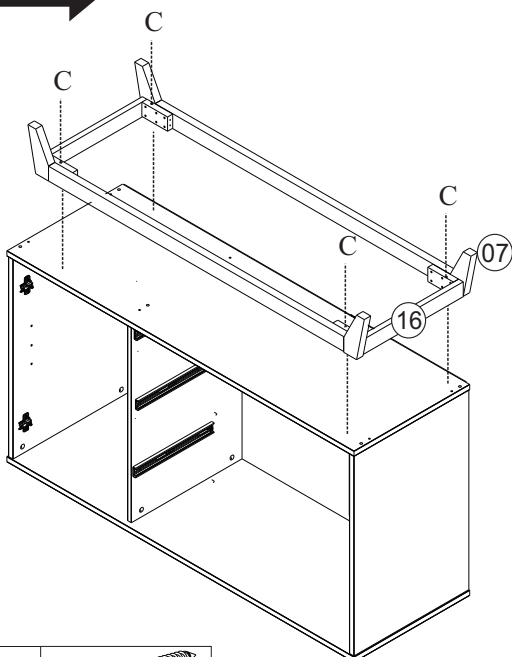

12

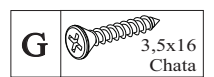
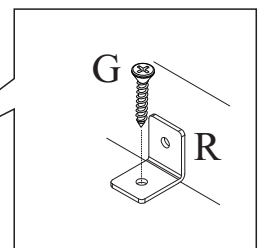
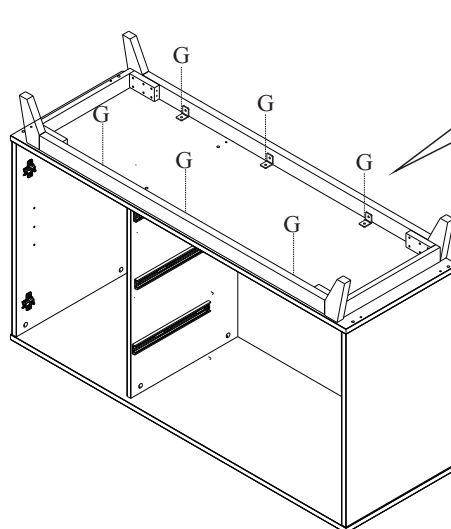

13

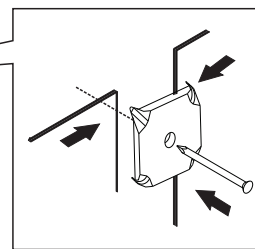
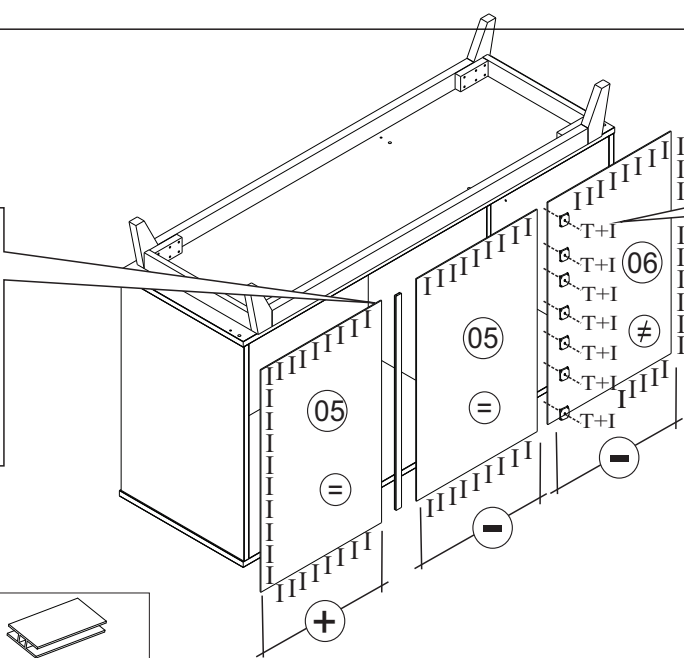
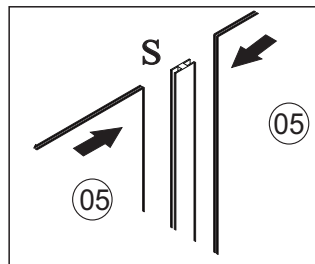

180°

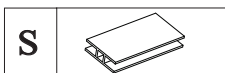
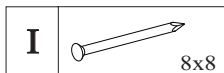
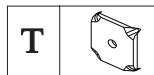
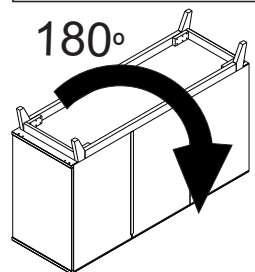

14

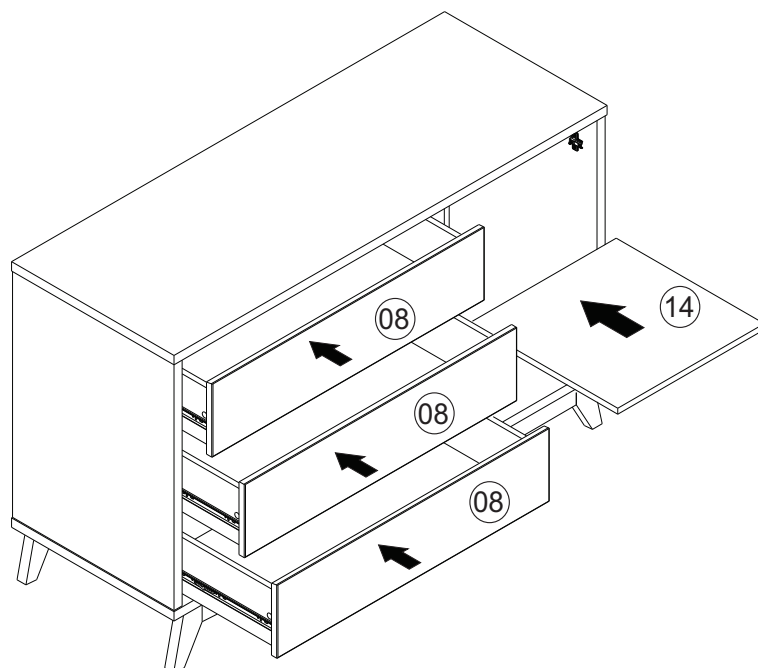

15

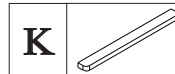
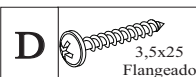
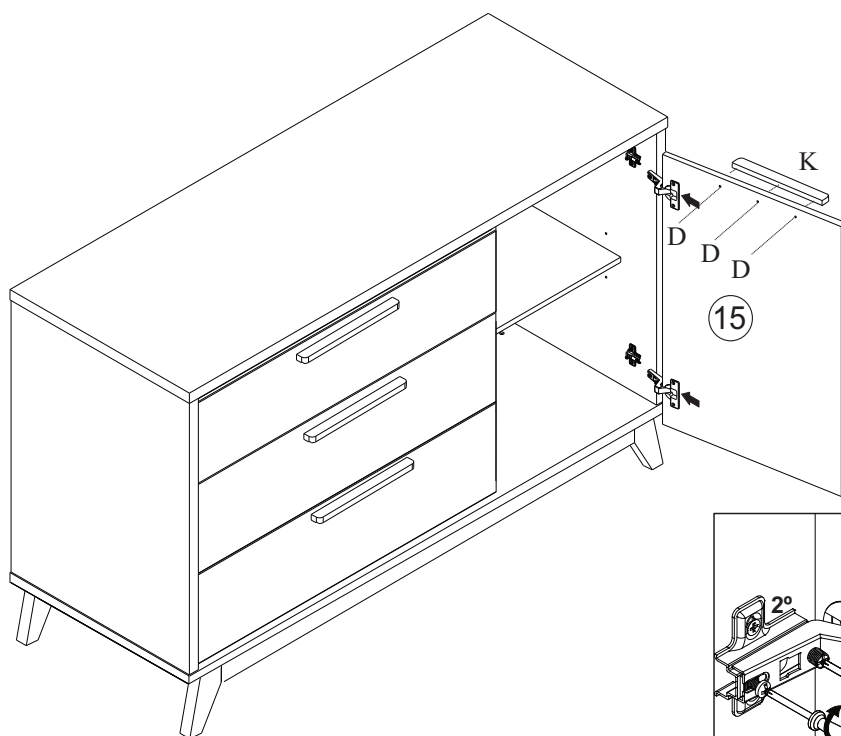

1°

2°

