

Ref. 14400

| | | |
|---|-------------------------------------|-----|
| A | | 30 |
| B | | 30 |
| C | 4,5x60 Flangeado | 04 |
| D | 3,5x25 Flangeado | 16 |
| E | 4,0x45 Chata | 06 |
| F | 4,0x12 Chata | 16 |
| G | 3,5x16 Chata | 12 |
| H | 4,0x12 Panela | 24 |
| I | 8x8 | 100 |
| J | 8x30 | 44 |
| K | Puxador 280mm | 02 |
| L | ø35 Dobradiça Super Curva | 07 |

| | | |
|---|-------------------------------|-------------|
| M | Calço Super Curva | 07 |
| N | 6,0x12 | 20 |
| O | 350mm | 04 Peças |
| P | | 04 |
| Q | | 12 |
| R | | 06 |
| S | 1883mm | 01 |
| T | | 15 |
| U | | 02 |
| V | 854mm | 01 |
| W | 4,5x50 Flangeado | 08 |
| X | ø35 Dobradiça Curva | 03 |
| Y | Calço Curva | 03 |
| Z | Puxador 152mm | 03 |

Utilizar a régua abaixo para medir os componentes.

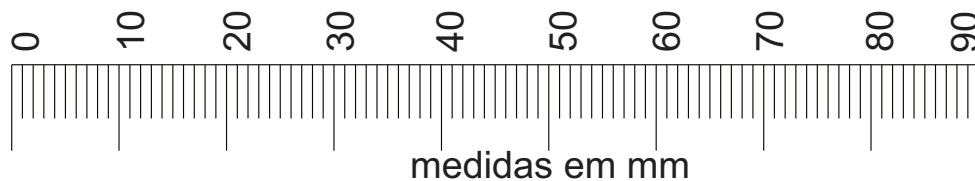

| Nº Peça | Nome da Peça | Qtde |
|---------|-----------------------|------|
| 1 | Tampo | 01 |
| 2 | Lateral Esquerda | 01 |
| 3 | Divisória | 01 |
| 4 | Lateral Direita | 01 |
| 5 | Fundo | 01 |
| 6 | Prateleira Fixa Maior | 03 |
| 7 | Prateleira Fixa Menor | 01 |
| 8 | Prateleira Móvel | 03 |
| 9 | Travessa Lateral Pé | 02 |
| 10 | Pé Montado | 02 |
| 11 | Frente de Gaveta | 02 |
| 12 | Lateral de Gaveta | 04 |
| 13 | Furndo de Gaveta | 02 |
| 14 | Traseiro de Gaveta | 02 |
| 15 | Travessa de Gaveta | 02 |
| 16 | Porta Pequena | 02 |
| 17 | Porta Grande | 01 |
| 18 | Traseiro Estreito | 02 |
| 19 | Traseiro Largo | 01 |

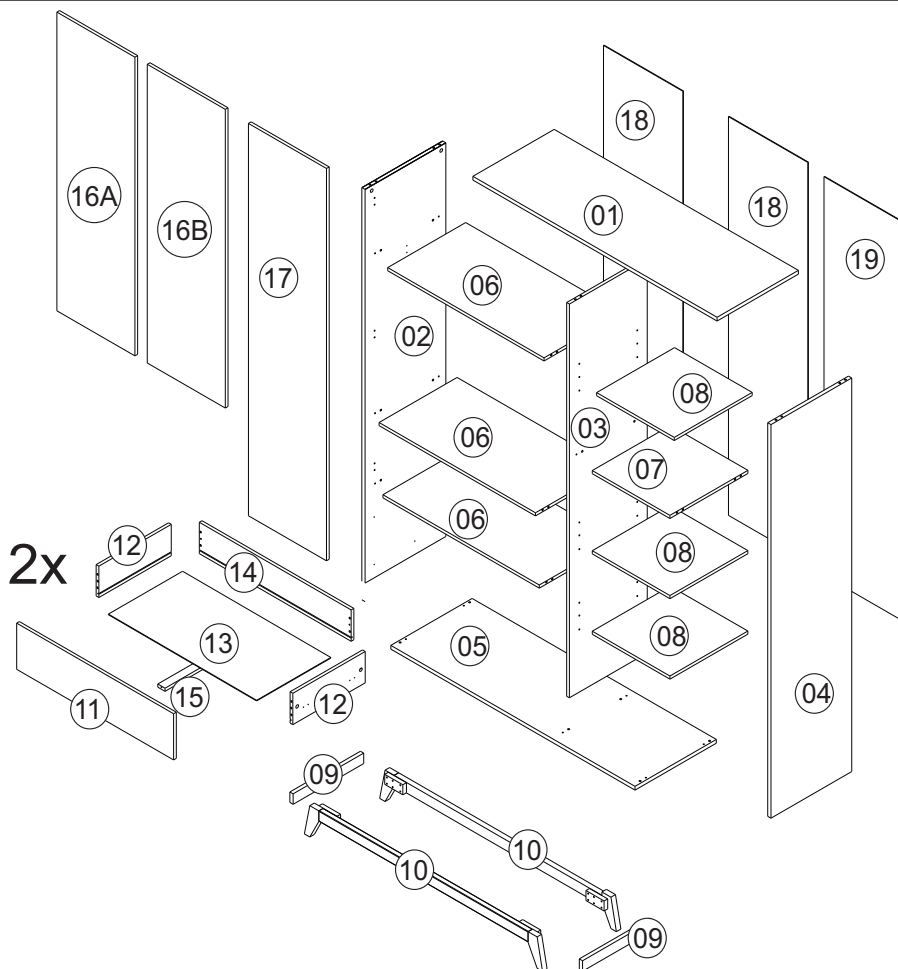

| | | |
|--|-------------|-----------------------|
| Ferramentas não fornecidas, mas necessárias para a montagem do produto | | |
| | Martelo | Chave Phillips |
| | | |
| | Chave Fenda | Furadeira Broca Ø 5mm |

01

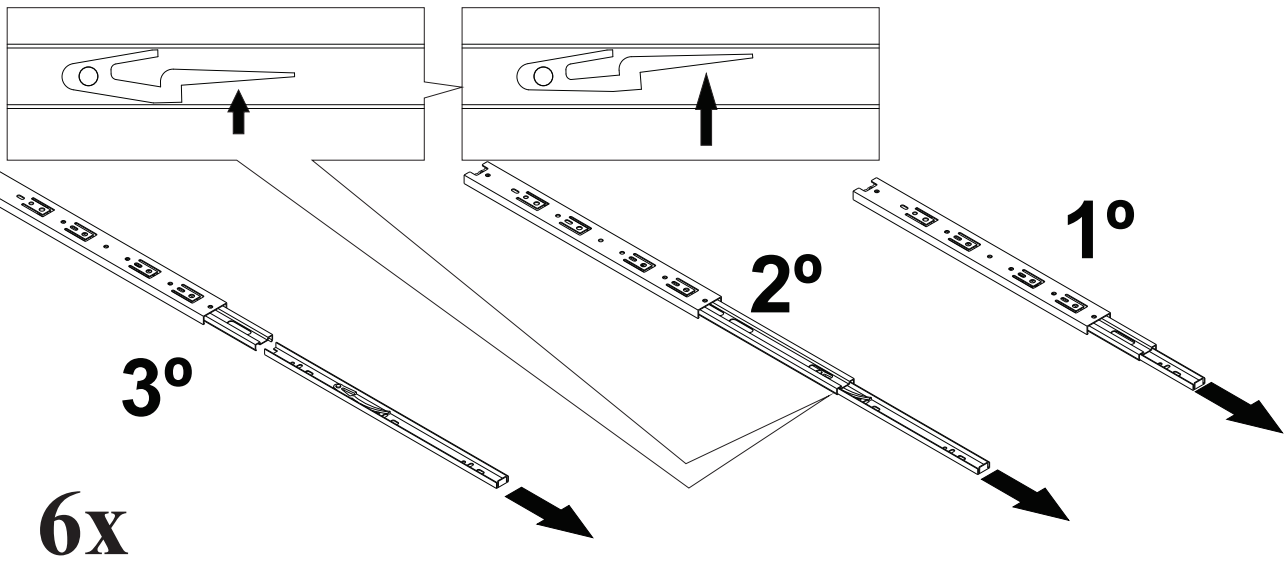

| | | | |
|----------|--|----------|--|
| M | | Y | |
|----------|--|----------|--|

| | |
|----------|--|
| N | |
|----------|--|

02

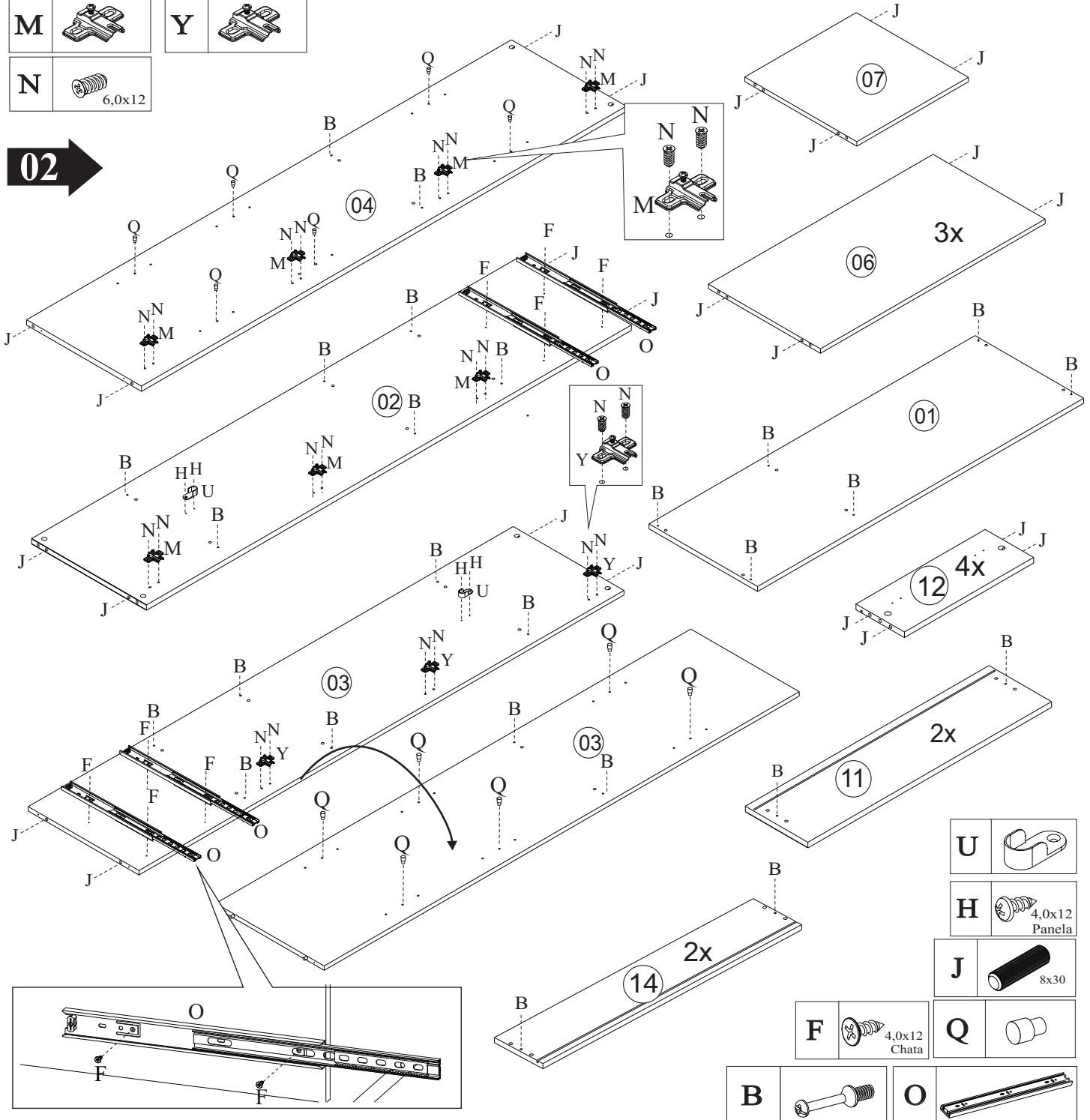

| | |
|----------|--|
| U | |
|----------|--|

| | |
|----------|--|
| H | |
|----------|--|

| | |
|----------|--|
| J | |
|----------|--|

| | |
|----------|--|
| F | |
|----------|--|

| | |
|----------|--|
| Q | |
|----------|--|

| | |
|----------|--|
| B | |
|----------|--|

| | |
|----------|--|
| O | |
|----------|--|

03

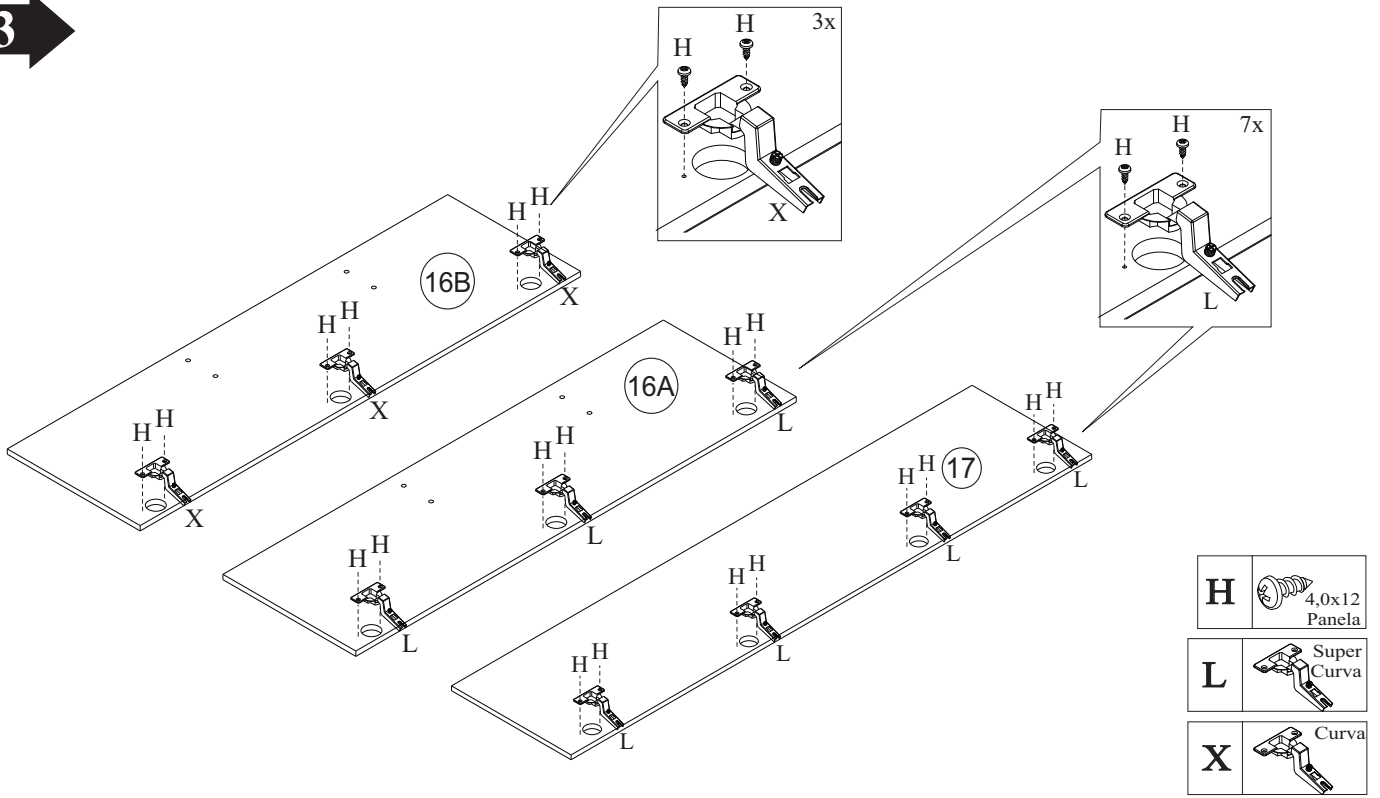

04

(2x)

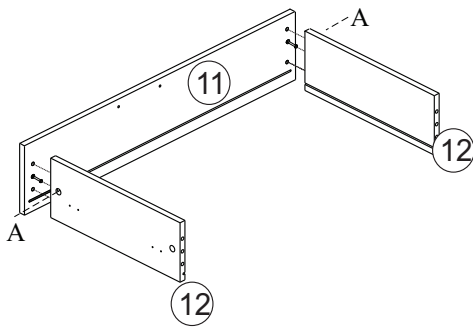

05

Fazer furos para puxador utilizando broca ø5

(2x)

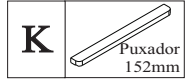
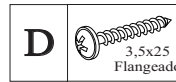
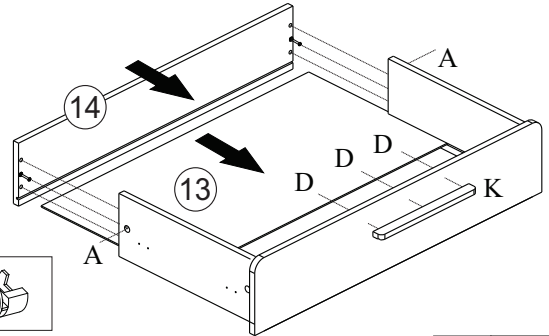

06

(2x)

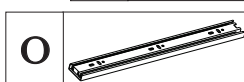
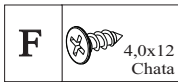
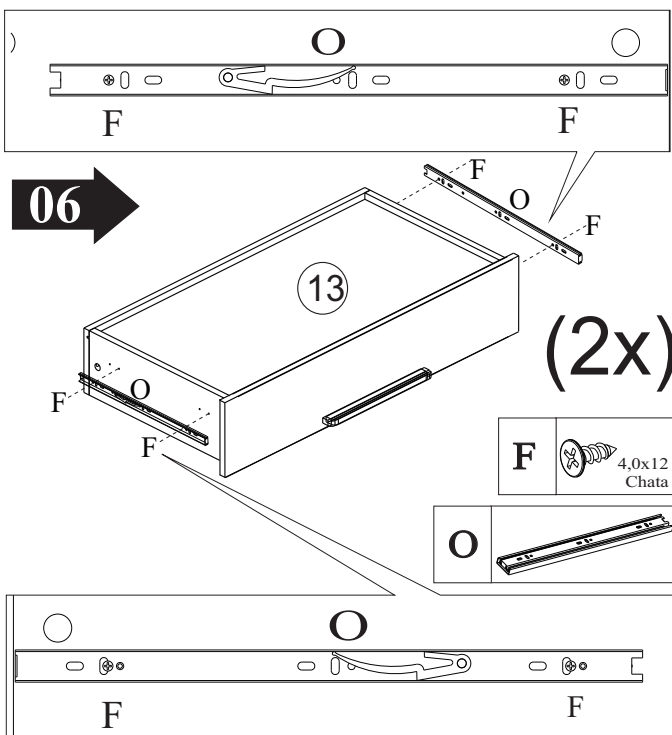

07

(2x)

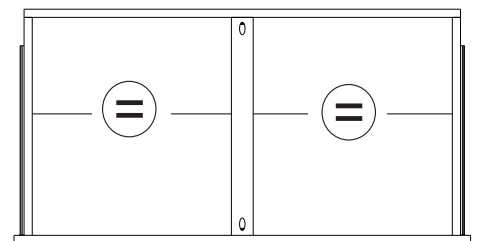
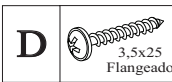
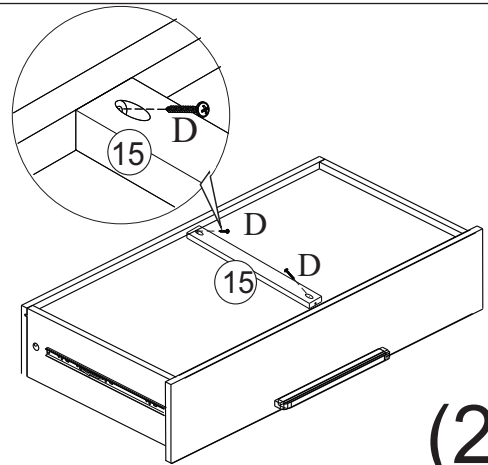

08

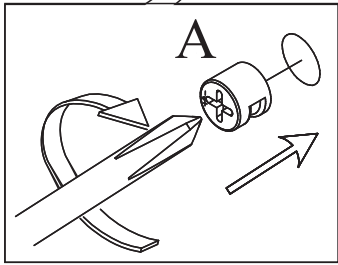
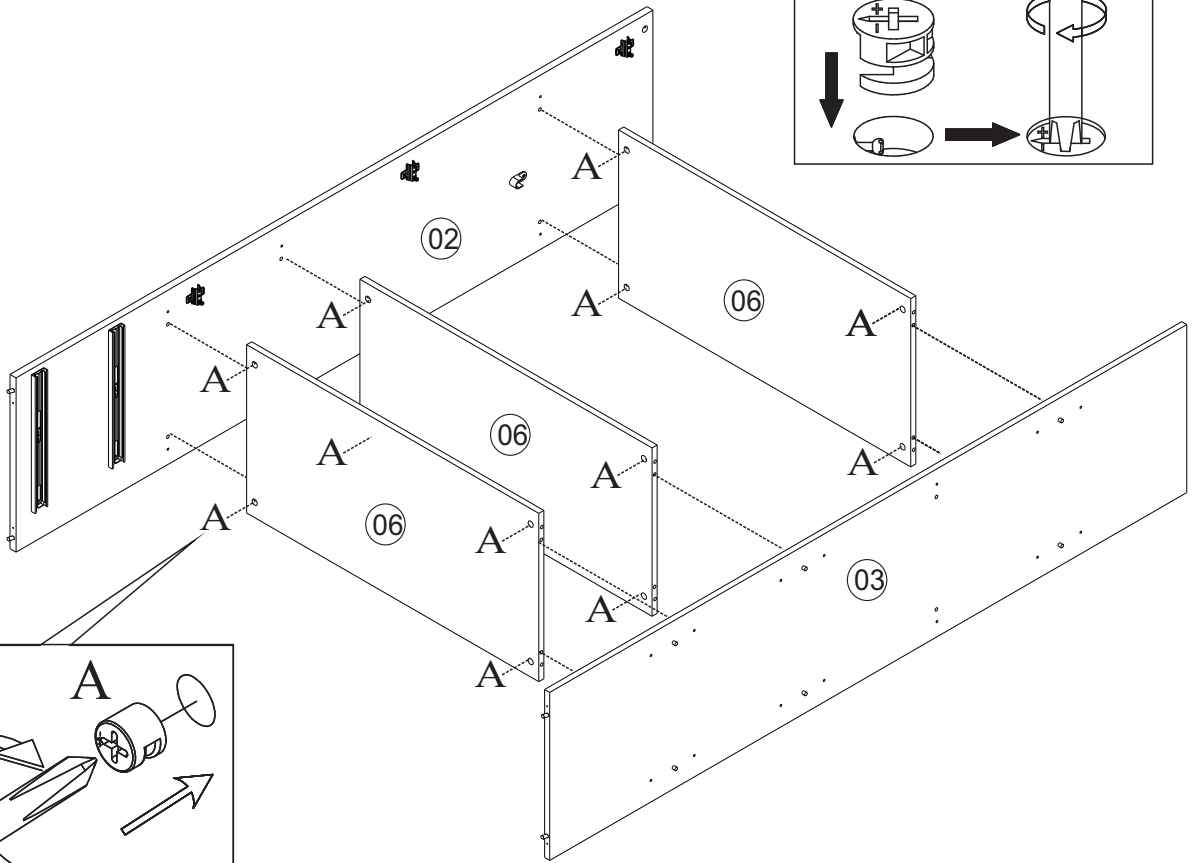
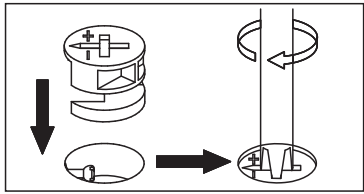

09

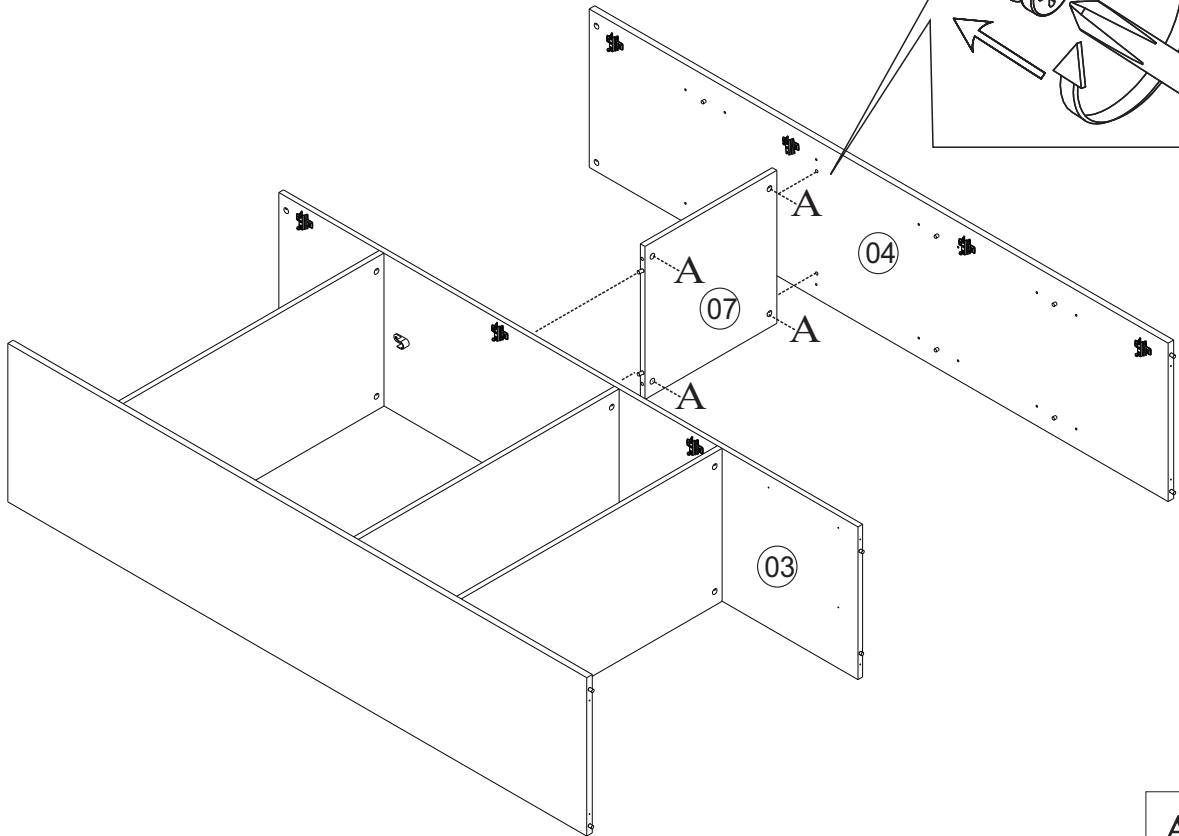
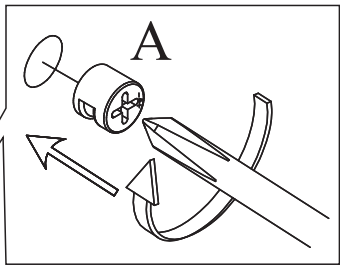

10

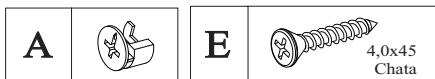
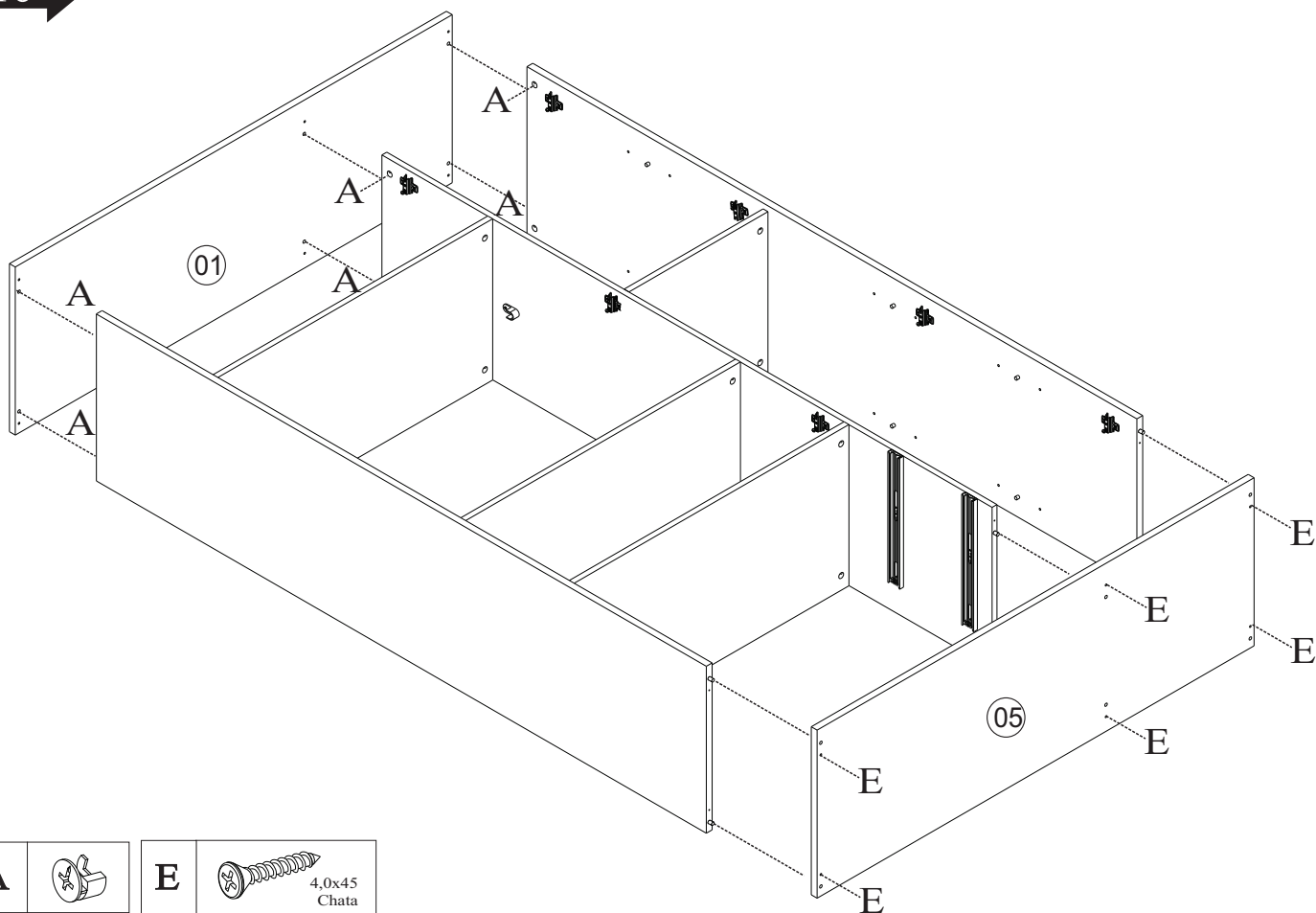

11

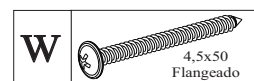
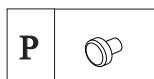
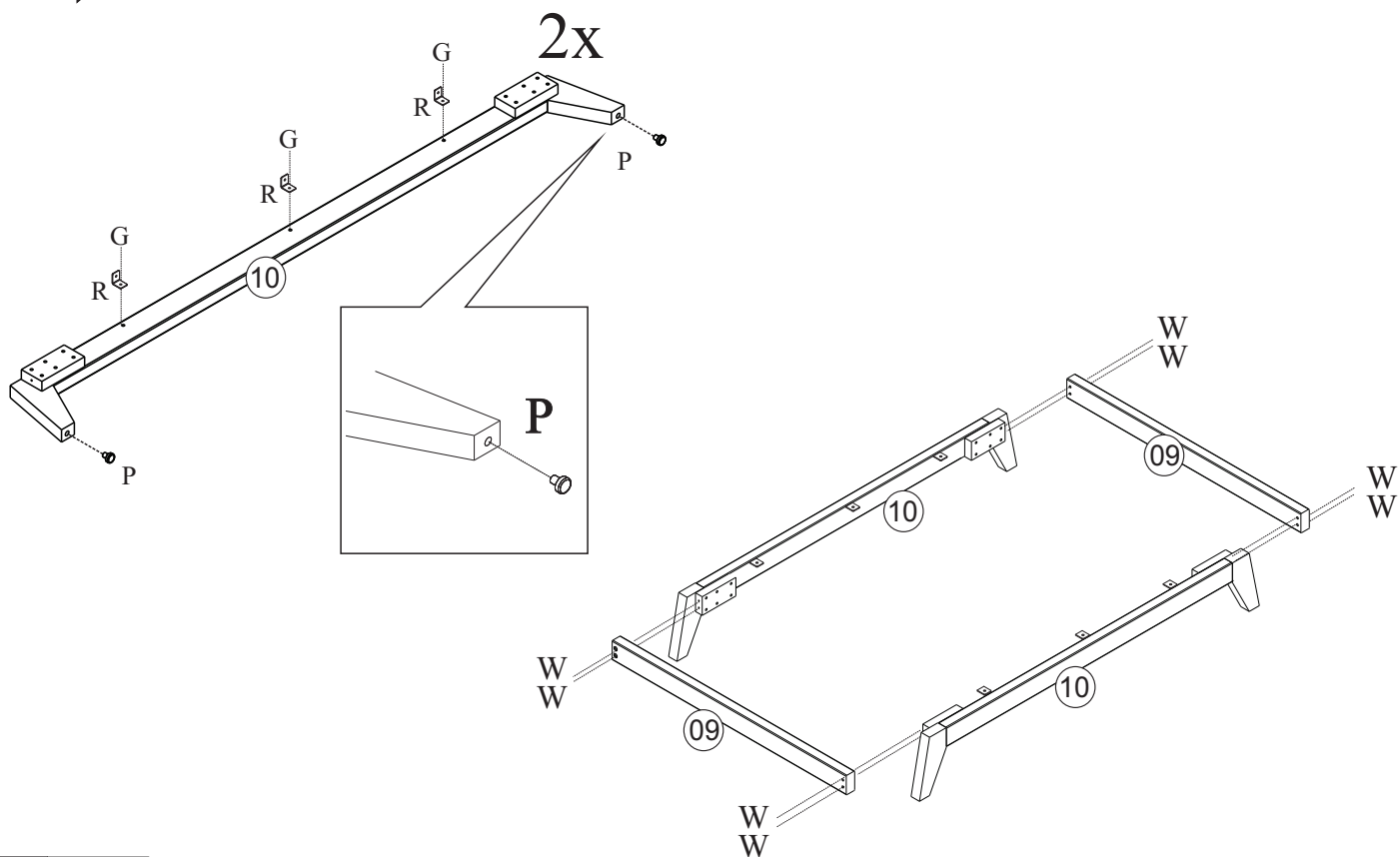

12

- C 4,5x60 Flangeado
- G 3,5x16 Chata

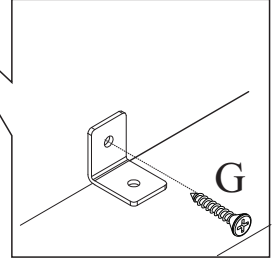
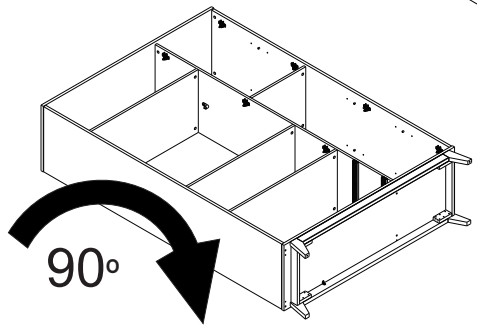
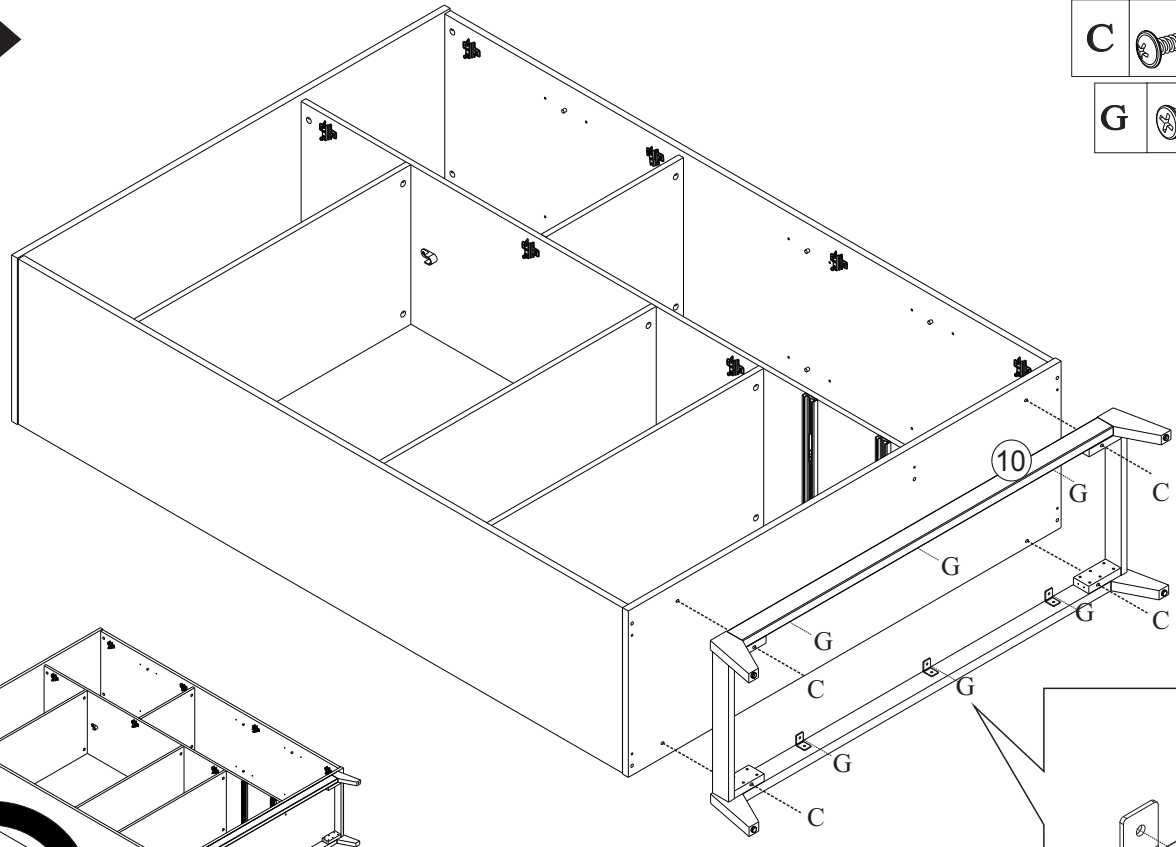

12

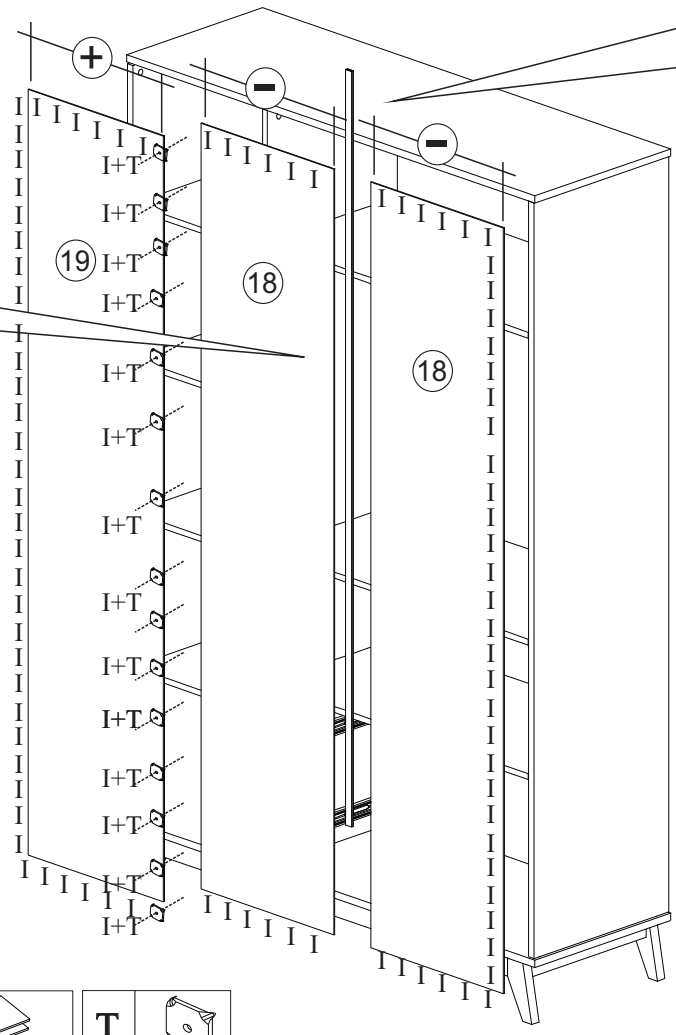
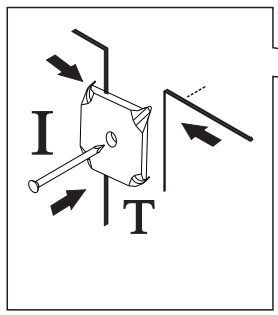
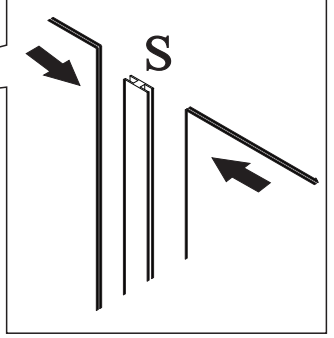

- I 8x8
- S
- T

14

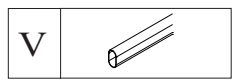
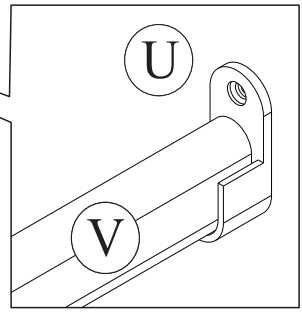
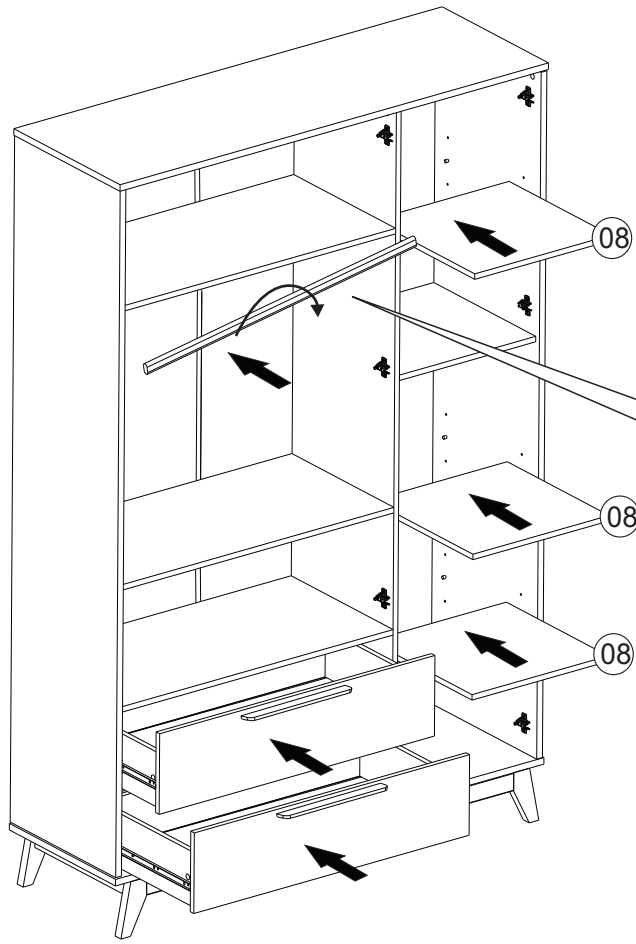

15

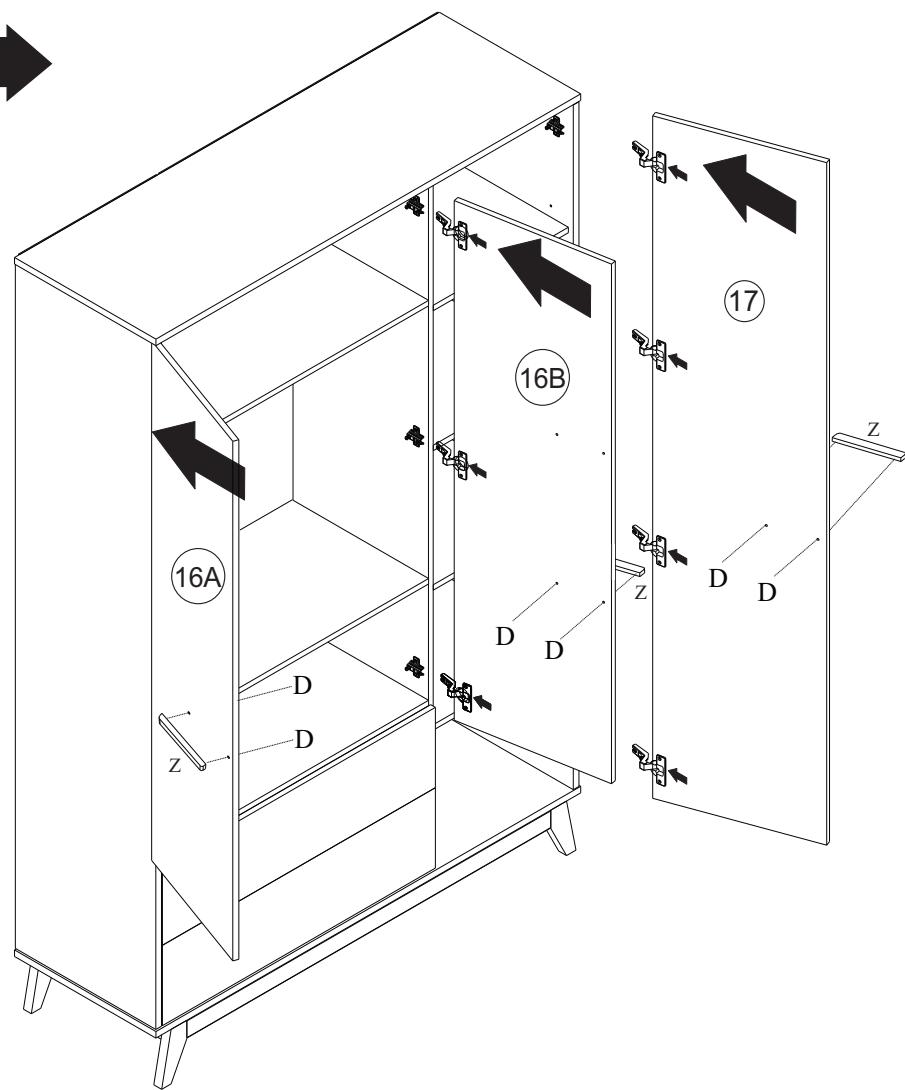

1°

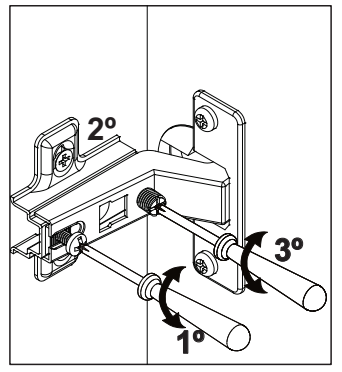

2°

