

RPS WATER PUMPS INSTALLATION MANUAL



RPS
WATER PUMPS

RPS | Rural Power Systems
40250 County Road 27
Woodland, CA 95776



rpswaterpumps.com



help@RPSwaterpumps.com





CALL or TEXT 855-560-5670

OUR PLEDGE TO YOU

Dear Customers,

In an effort to shape the way our company does business, our mission statement includes a series of pledges to you, our customers.

-  **We pledge to give you the power!** Controlling your own ability to pump water out of the ground, whether in the field or at home, allows you to be more resilient. You just bring the DIY spirit! Our engineers will be on the other end to offer specialized knowledge and answer questions, so you can install our RPS Water Pumps confidently and gain total control over your water supply.

-  **We pledge to be a company our grandfathers would have trusted.** The all-too-common practice of outsourcing customer support after the sale is one we wholeheartedly oppose. We are an American, family-run company and our USA engineers, who will support you before and after the sale, are the best in the industry. We gain most of our business from word-of-mouth as a result of treating customers with respect and standing by our products.

-  **No Pressure. Ever.** Our sales team is not on commission—we think this is important. Their role is to match you with the right pump for your well. If we don't have a pump that will suit your needs, we'll help you find a solution elsewhere. Our job is to help get you water, not sell you something that isn't a good fit.

-  **We pledge to bring you reliable water!** All manufactured products have occasional issues and we can't claim to be perfect. Well water varies in pH, iron level, and sand content. With that said, we are extremely proud of our 100% track record in getting our customers water. That's right, every single one of our customers is now successfully pumping water with an RPS system. This starts with making sure we supply you with the right pump for your land, and if issues do arise, we will immediately provide technical support and replacement parts so you can get up and pumping again as quickly as possible.

Sincerely,
The RPS Family

Copyright © 2023.2 Rural Power Systems Inc. All rights reserved.

The contents of this manual may not be reproduced, distributed, sold, or used in any manner whatsoever without the express written permission of Rural Power Systems Inc.



TABLE OF CONTENTS

System Components.....	6
Things You Will Need.....	6,7
Pre-install Planning.....	9
Fuse/Breaker Overview.....	11
110V Submersible Instructions.....	12
Starter Box Overview.....	14
Splicing Wires.....	15
Pump Assembly.....	17
Grounding.....	18
Starter Box Wiring.....	19
Pressure Switch Wiring.....	20
220V Outlet Wiring.....	21
Piping.....	22
Plumbing.....	25
Pitless Adapter.....	27
Diagrams.....	28
Bucket Test.....	30
Final Checklist.....	31
Using a Generator.....	32
Troubleshooting.....	33



RPS
WATER PUMPS

DIY INSTALLATION WARNING; ASSUMPTION OF RISK

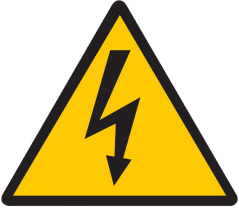

RPS Water Pumps (“RPS Products”) come with an easy to install Do-It-Yourself (“DIY”) kit intended for the consumer to install themselves or with the help of others. **THE RISK OF INJURY AND ELECTRIC SHOCK EXISTS AND COULD RESULT IN SERIOUS BODILY INJURY OR DEATH.** You are the best judge of your own capacity and qualifications to determine whether you can install the RPS Products or if you require assistance. Only qualified persons should install the products. Turn off power before installing. By purchasing an RPS Product, you acknowledge the potential risks and agree to assume all such risks of injury, including death.

In some cases, you may decide to hire a professional to complete some or all of the installation. Whether self-installed or professionally installed, RPS Water Pumps is unable to guarantee or offer any compensation for troubleshooting, replacing parts, pulling pumps or anything else involved in the troubleshooting/ replacement process, regardless of the reason for the warranty claim.

But never fear, RPS Water Pumps has tens of thousands of customers across the USA who have successfully installed and, in those rare cases, troubleshoot their system with the help of our dedicated RPS Water Pumps support engineers!

Please exercise caution when installing your well pump and follow the step-by-step instructions in this manual for your safety. Whenever you’re working with electrical wiring or connections, make sure:

- power switch and/or breaker is set to OFF,, other power sources are disconnected
- to remove exposed jewelry or other metallic items
- to ground the system for safety and to prevent damage to equipment

LIMITATION OF LIABILITY

TO THE MAXIMUM EXTENT PERMITTED BY APPLICABLE LAW, IN NO EVENT SHALL RPS Water PUMPS BE LIABLE FOR ANY CONSEQUENTIAL, INDIRECT, INCIDENTAL, SPECIAL, EXEMPLARY, PUNITIVE, OR ENHANCED DAMAGES, LOST PROFITS OR REVENUES OR DIMINUTION IN VALUE, ARISING OUT OF, OR RELATING TO, AND/OR IN CONNECTION WITH ANY BREACH OF THIS AGREEMENT, REGARDLESS OF (A) WHETHER SUCH DAMAGES WERE FORESEEABLE, (B) WHETHER OR NOT RPS Water PUMPS WAS ADVISED OF THE POSSIBILITY OF SUCH DAMAGES, (C) THE LEGAL OR EQUITABLE THEORY (CONTRACT, TORT OR OTHERWISE) UPON WHICH THE CLAIM IS BASED, AND (D) THE FAILURE OF ANY AGREED OR OTHER REMEDY OF ITS ESSENTIAL PURPOSE. IN NO EVENT SHALL RPS Water PUMPS’ AGGREGATE LIABILITY ARISING OUT OF OR RELATED TO THIS AGREEMENT OF THE RPS PRODUCTS, EXCEED THE TOTAL OF THE AMOUNTS PAID TO RPS Water PUMPS FOR THE PRODUCTS PURCHASED BY CUSTOMER.



WARNING

- **Ground the system before turning on.** Improper grounding may cause shock, burns, damage to property or death
- Abide by local electrical and building codes or ordinances when installing. Follow the **National Electrical Code (NEC) and Canadian Electrical Code as required.**
- Do not use motor in swimming areas without proper grounding
- **Disconnect power to the pump system before installing or performing service**
- Do not over pressurized pump system components like the pressure tank or piping. Overpressurizing may result in a serious risk of injury
- Ensure that the **electrical supply voltage matches the equipment specifications**
- Only use this pump with clear water free of excess sediments, fine gravel, and precipitates from TDS levels exceeding 2000ppm may affect operation
- Ensure **waterproof wire splices**
- Install a disconnect switch where required by code
- Ensure that there is **adequate flow of water to cool the motor** if the pump is placed below the casing perforations.
- If powering the pump with a generator you should use a manual or automatic transfer switch. Failure to do so may result in injury.

Quickstart Overview of Install

Step 1: Screw Pump end and motor end together, see Page 18.

Step 2: Splice submersible pump wire extension cable onto 6 ft pigtail. Make sure you splice enough wire onto the pigtail to run from your pump to the location of your starter box. See Page 16.

Step 3 : Attach safety rope to pump eyelet see Page 24 and Page 25.

Step 4: If using poly pipe, roll out your poly pipe and allow it to relax/warm up, see Page 23 and 24. Attach plumbing off of pump, see Page 26. Then connect plumbing from pump to water pipe. See Page 28.

Step 5: Assemble well seal and associated plumbing for the top of your well. See Page 28. If using poly pipe, you'll now attach the well seal assembly to the top of your poly pipe. If using a pitless adapter assembly see Page 29. Thread wire and safety rope through the smaller, secondary hole in the well seal.

OPTION BUCKET TEST STEP + PRE-LOWER CHECKLIST SEE PAGES 31 and 32

Step 6: Lower pump into well, careful to not hit the pump against the sides of the well casing. Once pump assembly is in place in the well, move onto wiring the control box with the submersible pump wire. See Page 19 and 20.

Step 7: Now wire in pressure switch (if you're using a pressure tank or pressure system) see Page 21, and then wire from pressure switch to breaker box.

Quick Look Install Tips

- For any system capable of producing more than 75 PSI of pressure, we recommend installing a pressure relief valve.
- Check that the pressure rating of your pipe is higher than the upper limit pump shut off pressure.
- Ensure that all the plumbing connections are tight and wrapped with Teflon tape.
- Place the pressure switch within 4 feet of the pressure tank.
- Wiring and grounding should be in compliance with national and local electrical code.
- If using a pressure switch, adjust the pressure tank setting 2 PSI below what the system cut in pressure setting on the pressure switch is, ex 18 PSI on a 20/40 system.

Kit Components

Depending on the type of product you purchased from RPS Water Pumps, you may have received just a pump-end, just a motor-end, or a starter kit that includes a pump + motor + starter box. Alternatively, you may have purchased the pump+motor+starter box with a One and Done kit for easy DIY install..

Basic Kit Components

- Pump End
- Motor End
- Starter Box
- Splice Kit

One-and-Done Kit Components

- Pump Wire: Submersible Jacketed Copper Wire, 3 strand + Ground
- Poly Pipe
- Safety Rope
- Well Seal
- Electrical tape
- Teflon tape

If you chose the Well Seal Option...

- Well seal assembly (4", 5", 6", 8") with well seal, 1.25" stainless threaded nipple, 1.25" stainless threaded tee with hex plug, 1.25"-->1" stainless coupler, 1" stainless hose barb and stainless hose clamps for the barb.

If you chose the Pitless Adapter option...

- Well Cap (4", 5", 6" or 8"), 1" stainless steel hose barb and 1" Pitless Adapter Assembly

Things You Will Need: Tools and Parts

- Teflon Tape
- Electrical Tape
- Pressure Switch (if using pressure tank or pressure system)
- Wire Strippers
- Voltmeter
- Flat and Phillips Screwdriver
- Lighter or heatgun for heatshrinks, heating poly pipe for tighter hose clamps



THINGS YOU WILL NEED Continued...

Recommended Equipment

If you didn't purchase the One-and-Done easy install kit, you'll need to supply your own parts including....

- Pipe: You can choose what kind of pipe works for your install, usually customers choose between poly pipe, PVC, or steel galvanized pipe. Here's a chart on general guidelines for how to choose pipe based on your project specs...

	160PSI Poly Pipe	200PSI Poly Pipe	250PSI Poly Pipe	PVC Schedule 80	PVC Schedule 120	Steel Galvanized
Up to 300 feet	X*	X*	X*	X	X	X
350 feet		X*	X*	X	X	X
400 feet		X*	X*	X	X	X
450 feet			X*	X	X	X
500 feet				X	X	X
550 feet				X	X	X
600 feet				X	X	X
650 feet				X	X	X
700 feet					X	X
750 feet					X	X
800 feet						X
850 feet						X
900 feet						X
950 feet						X
1,000 feet						X

*Preferred for low cost and ease of use

THINGS YOU WILL NEED Continued...

- Pump Wire/Cable: Only use wire that is rated as “UL Listed as Deep Well Submersible Pump Cable”. Depending on the depth of your well and the HP of your pump, you’ll be using 12, 10 or 8 gauge 3 Conductor+Ground heavy duty flat jacketed submersible pump cable. The deeper the well, the higher gauge you’ll have to use to account for voltage drop across distances.

HP of 220V Pump	Wire Gauge, Single Phase 3+G, 60HZ, 75°C Cable (feet)						
	14	12	10	8	6	4	3
1/2	400	650	1020	1610	2510	3880	4350
3/4	300	480	760	1200	1870	2890	3300
1	250	400	630	990	1540	2380	2830
1.5	190	310	480	770	1200	1870	2470
2	150	250	390	620	970	1910	2250
3	120	190	300	470	750	1190	1660
5	0	100	200	320	500	800	1015

Submersible Pump Wire

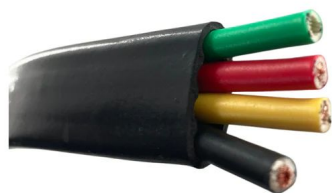

NM-B Wire

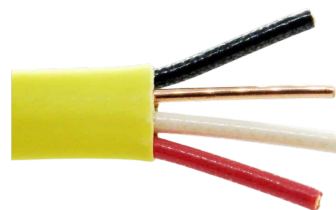

- NM-B Wire: to connect the pump starter box with your breaker box. See page 10 for wire gauge recommendations.
- Large water bucket or tank for testing the pump operation once all wired up, but BEFORE you send the pump down well. See page 26.



Step 1: Start with a Clean Well

Before installing a new pump, make sure that your well is fully developed, free of debris, obstructions, well drilling material and sand. RPS Water Pumps are Stainless Steel pumps are very resistant to abrasion, but there has been the occasional pump that was worn down over time by leftover well drilling materials- i.e heavy sand and silt. Submersible pumps are designed to work best in cold, clear water that does not exceed 102 degrees F. Test your well production rate. This number may also be written on the well log from the original drilling report. Ensure that the pump you have purchased does not exceed the refresh rate of your well.

Step 2: Pre-Install Planning

Plan on placing your pump at least 20 feet off the bottom of the well. This is the standard industry recommendation placement, 20 feet prevents the pump coming in contact with settled debris and sand that settles at the bottom. If your well is slow flow and/or you have a really short water column, you could place it closer to the bottom, just be aware that the pump operation may kick up some sediment. In some areas of the USA, sediment and sand really isn't a problem, so base this advice on your areas unique water table characteristics! As long as the pump is located within the limits of the 600 foot maximum submersion limit (how far underneath the static water level the pump can go), you're all good! There's no real

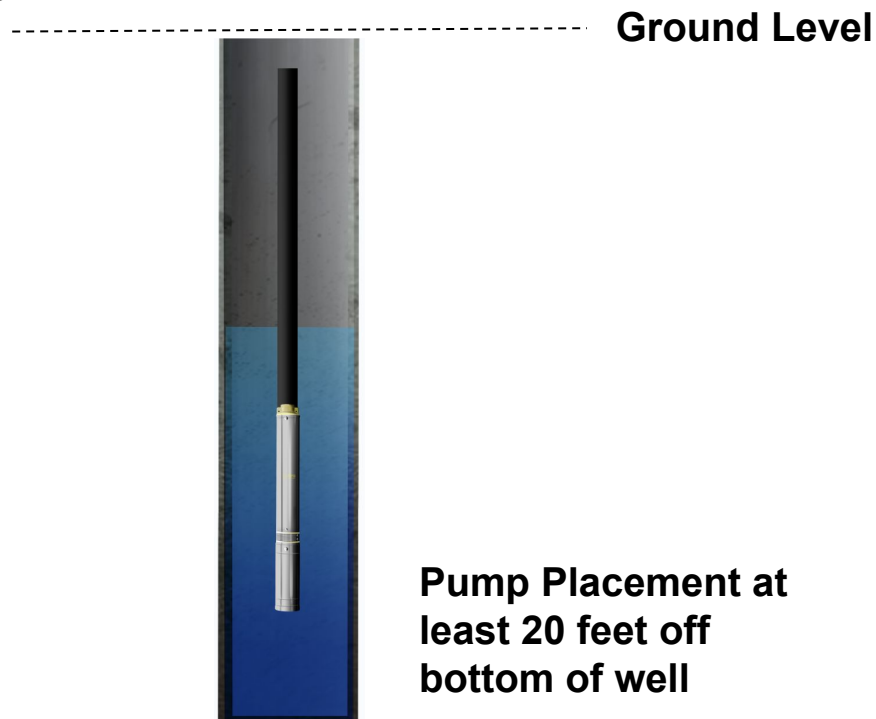

Pre-Install Planning Continued...

Before installing, check that the wire gauge is suitable for the Horsepower of your pump and length of wire from pump to starter box. If the wire is of insufficient gauge, you may experience poor performance from voltage drop or overheating wires.

Purchase pump wire that is rated for underwater use, usually labeled as “heavy duty submersible flat jacketed pump cable”, “UL Listed per UL 83 Type THW as Deep Well Submersible Pump Cable” “black PVC jacketing”. Select 3 conductor wire with a ground, for a total of 4 insulated wires. Use copper conductors when making connections between the pump and starter box as well as between the starter box and fuse/breaker box.

Measure and calculate distance of wire from the pump to the starter box. Add together # of feet down to pump in well + feet from well to starter box to get your total drop wire length required.

Motor Horsepower (single phase 220v)	Copper Wire Size for Pump to Starter Box Connection				
	12	10	8	6	4
1/2	625	1000	1600	2500	4800
3/4	450	750	1150	1850	3850
1	400	600	950	1500	2950
1.5	300	450	750	1200	1850
2	250	350	600	950	1500
3	150	300	450	750	1150
5	100	150	250	450	700



Pre-Install Planning Continued: Check Breaker / Fuse Box

Check that your breaker voltage rating for the pump connection is 220V, and has space with a two pole breaker.

Check that the fuse or breaker is also rated for sufficient amps for powering the water pump. If you're replacing a pump with another pump of the same HP, the breaker rating should be fine. If you are replacing with a greater HP, you may need a breaker with a higher rating. The breaker panel should have a wiring assignment on the inside of the front door, use this to identify which circuit is your submersible pump and de-energize the circuit before installing. You should see that the breaker takes up two adjacent spaces, identifying it as a 220V system, a single breaker would mean that the breaker is only a 110V.

If wiring from the starter box to breaker is pre-existing, skip to next step. Measure the distance from starter box to fuse/breaker box. UF-B direct burial or THHN/THWN wire pulled through conduit are suitable methods of wiring the starter box to the breaker. You must comply with local electrical and building ordinances when installing wire to the breaker.

HP	Volts	Circuit Breaker Amps	Standard Fuse Amps	NM-B Wire Gauge Necessary
½ HP	110V	15	15	14ga
½ HP	220V	15	15	14ga
¾ HP		20	20	12ga
1 HP		25	25	10ga
1 ½ HP		30	30	10ga
2 HP		30	30	10ga
3 HP		45	40	8ga
5 HP		70	60	4ga

Wiring rating for up to 100 feet of wire, if using more than 100 feet, use next largest gauge of wire. Safe maximum of amp drawn on breaker is 80% rated value of breaker.

110V Submersible Pump Instructions

110V Submersible Pumps do not use starter boxes. You'll be splicing your roll of pump wire onto the 6 foot pigtail off of the pump. Once above ground and out of the well, you'll be wiring into one of the following options.

- A) Submersible pump wire → pressure switch → breaker (See instructions on page 22)
- B) Submersible pump wire → wire directly to breaker
- C) Wire to a 110V plug that would connect to a 110V wall outlet. Instructions are on the next page.

The 6 foot pigtail off of the pump has three wires total, two blacks(one hot and one common) and a green(ground). Depending on where you purchase wire from, your extension pump cable may have wire colors of black/red/green or black/white/green or black/grey/green. As long as you match green to green, and one black to another black the third wires color pairing does not matter.

For putting the pump together and plumbing instructions follow the instructions on pages 15 to 25.



Installing a 110V Submersible Pump with a GFCI Outlet

Step 1: **Safety First** Before you begin, ensure that you turn off the power supply to the 110V outlet at your circuit breaker. This step is crucial to prevent electrical accidents during the installation.

Step 2: **Prepare the Pump Cable** Strip the ends of the pump wire.

Step 3: **Install a GFCI Outlet** in your desired location. GFCI outlets protect against electrical shock and are highly recommended for outdoor installations.

Step 4: Consult your local electrical code for restrictions on which option is best for your area.

Option #1 (recommended) Hardwire a. Attach the green or bare ground wire from the pump cable to the green screw on the GFCI outlet or to the ground terminal on the standard outlet. b. Connect the neutral wire(white, grey or red) from the pump cable to the silver or white terminal on the outlet. c. Connect the black hot wire from the pump cable to the brass or black terminal on the outlet.

Option #2 Plug Style Splice the pump wire from the submersible pump onto the pigtail from the 110V three prong NEMA power cord 15A rated plug (see right), matching up green to green, black to black. You can then plug the pump into a properly rated outlet. CAUTION this option can pose a tripping hazard.

Step 5: **Secure the Outlet** Secure the outlet in an appropriate electrical box, if not already installed. Use screws to fasten it securely to the wall or a post. Ensure that the wiring is neatly tucked inside the box.

Step 6: **Test the Connection** Before placing the submersible pump in water, turn the power back on at the circuit breaker. Test the outlet by plugging in a small device to ensure it's working correctly.

Step 7: **Submersible Pump Installation** Lower the submersible pump into the well. Follow instructions starting on page 23.



Step 3: Mounting the Starter Box

Protect the starter box from rain, snow and extreme temperatures, we recommend mounting it under some shade. Drill a screw into the mounting surface and hang the starter box on the slotted hole. Secure the box by opening the front cover and driving the second screw from the inside at the bottom. Knockouts are provided for routing conduit connections directly into the starter box.



Step 4: Wiring the Pump

Your RPS Water Pump will have a pigtail of wire that is to be connected with a splice kit to the rest of your pump wire. A splice kit is included in every pump kit purchase, once applied correctly the spliced wire will be conductive, watertight, and secure. However, do not use the wires to support the pump's weight as you position the pump or lower it down the well, as it may separate one or more of these connections. Once the wire and pipe are connected, and taped together as a bundle this is less of a concern as weight is distributed. See next page for visual guide to splicing wires. See page 20 for more tips.



SPLICE DEMONSTRATION

STEP 1

You will need a spool of heavy duty submersible flat jacket pump wire. Remove about 6 inches of the outer black jacketing to expose the colored wiring inside, be sure not to cut through the inner wiring jackets.

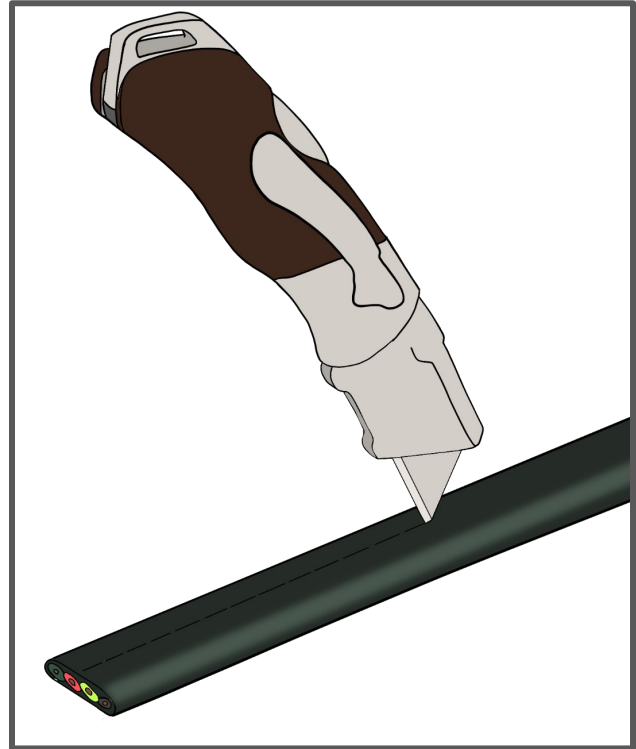
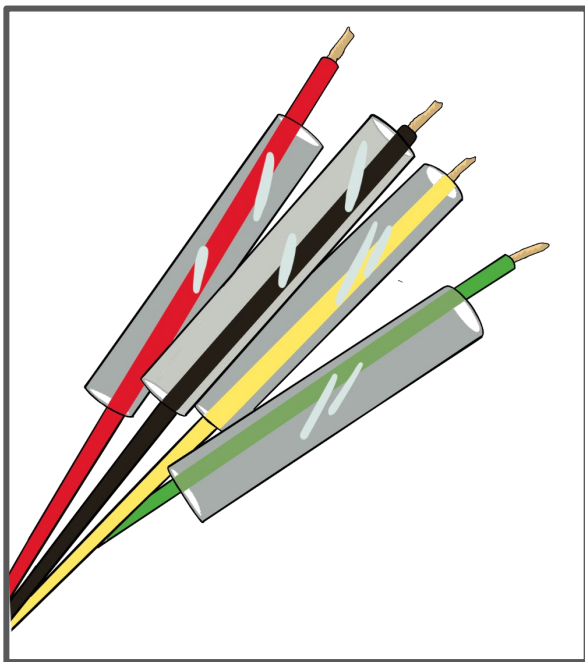

STEP 2

Strip both sets of wires ¼ inch length and place your heat shrink tubing over each strand of the wires coming from the pump motor.

STEP 3

Crimp the wires together, matching them by like colors if possible. Then using a butane torch/lighter or heat gun shrink the tubing over the crimp, creating a watertight seal. If using a lighter, move the flame quickly to spread the heat and prevent burning of the shrink tubing.

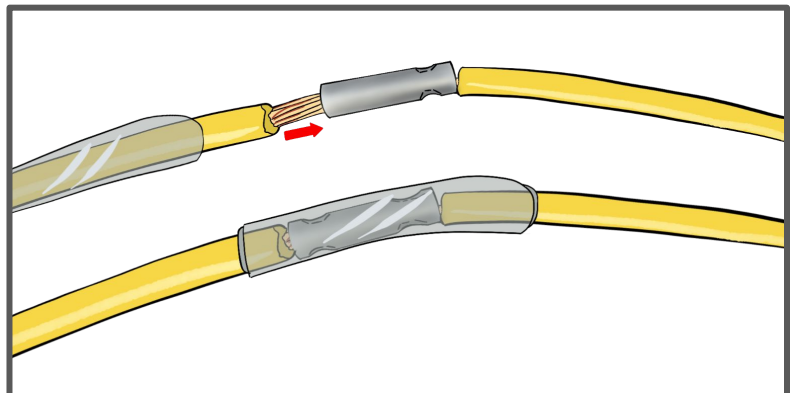

PRO TIP: When you seal the heat shrink tubing you want to see a small amount of adhesive squeezed out from the ends of the tubing

STEP 5: PUMP ASSEMBLY

STEP 1

Remove the 4 nuts on the top of your pump motor.
You will need a 1/2" wrench for this step.

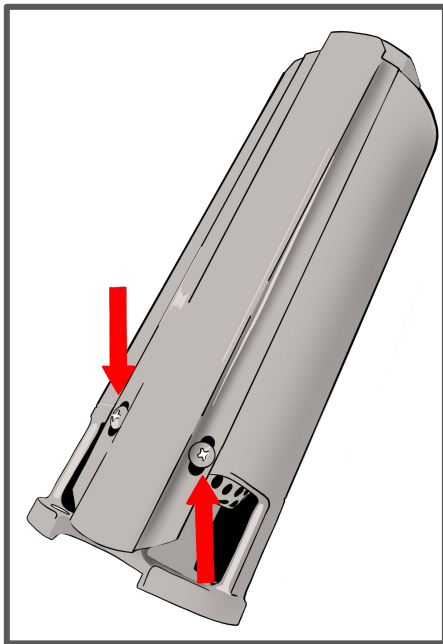
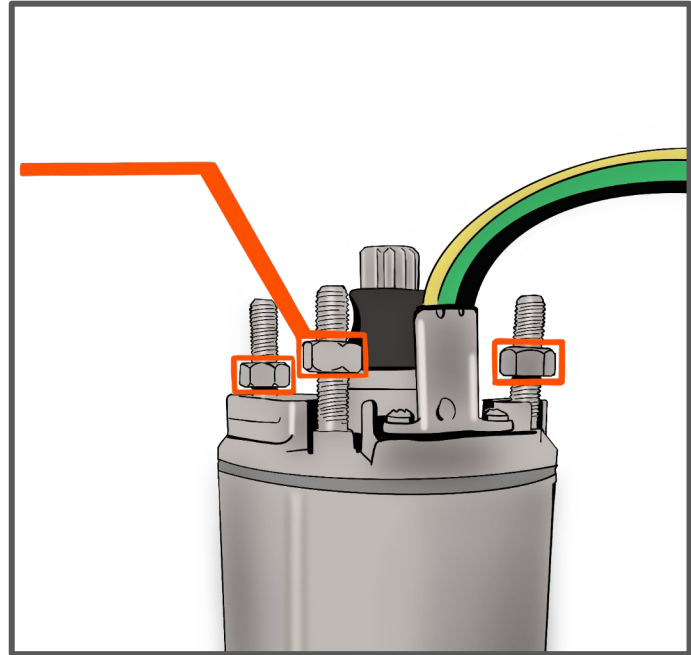

STEP 2

Remove the two screws on the wire protector located on the pump end.
You will need a medium sized philips head screwdriver for this step.

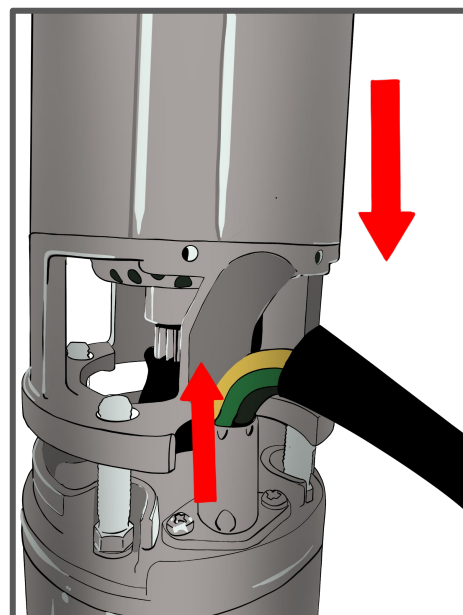

STEP 3

Place the pump end onto the motor allowing the bolts to pass through each of the holes leaving the side with extra space for the motor wires. If the pump does not slide on completely rotate the shaft on the pump end a little to get the splines to align with the motor's. Then secure the nuts with washers you previously removed. The exact torque value is 10 lb-ft (14 Nm)



PUMP ASSEMBLY CONT.

STEP 4

Run the wires from the pump motor up along the side of the pump end where the wire cover will go.

PRO TIP: To make the installation of the wire cover easier make sure the wires lay flush along the pump end.



STEP 5

Install the wire cover by fastening the two screws previously removed.

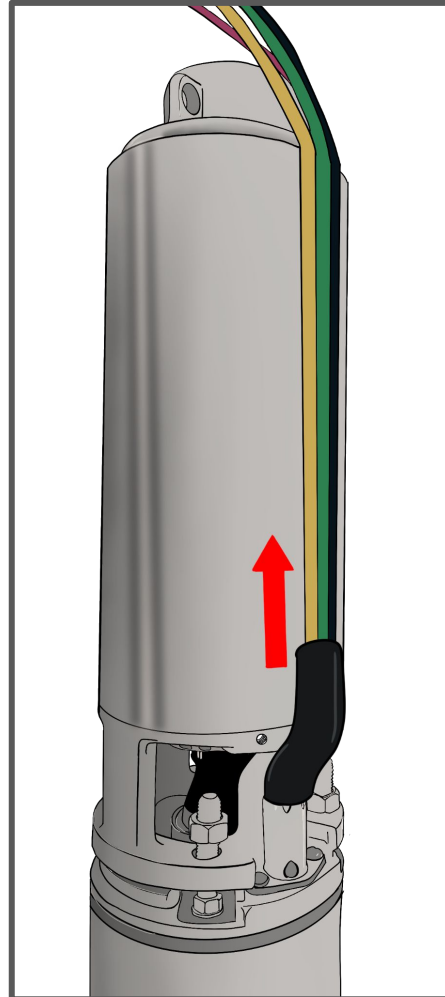
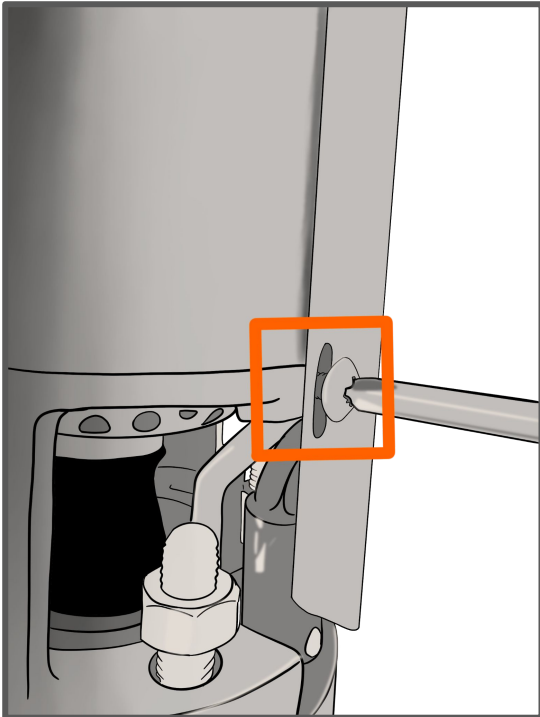

PRO TIP: The top of your wire cover is outfitted with a lip that fits securely over the sheath of your pump end. Secure this lip before fastening the screws to ensure proper fit.

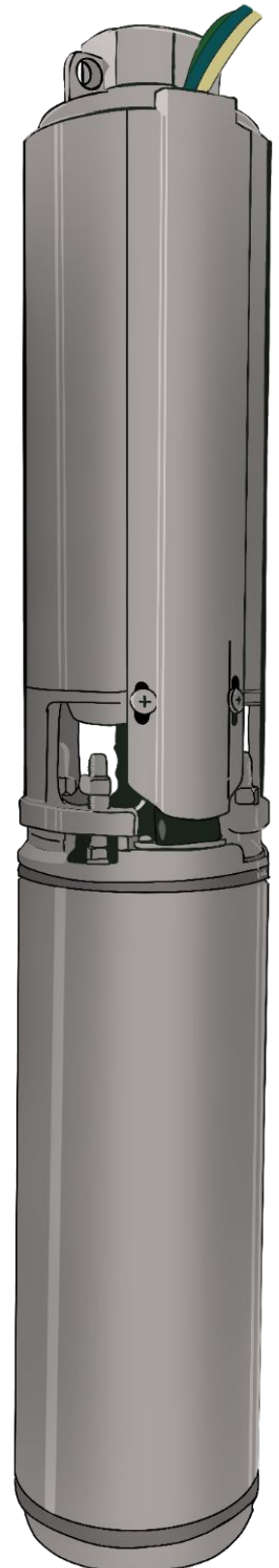
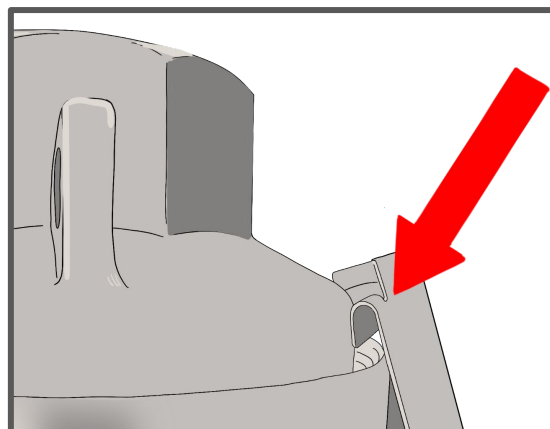

Step 6: Grounding

WARNING - TURN OFF THE POWER AT THE BREAKER BOX BEFORE BEGINNING ANY WIRING. Depressurize any lines in an existing system. Test the AC voltage at L1 and L2 in your existing starter box with a multimeter to verify the circuit has been de-energized if replacing existing work. Your pump wire will have four wires. The green is the designated ground. Separate out the ground from your line input, also known as the two hot wires connecting to L1 and L2 and out to the breaker box. Strip the insulation if present and use a fork or ring terminal to secure the ends of the ground wire (stripped wire end, insert into the plastic wrapping and clamp wire and fork terminal together). Repeat for other ground wire.

Diagram of grounding wiring connection:

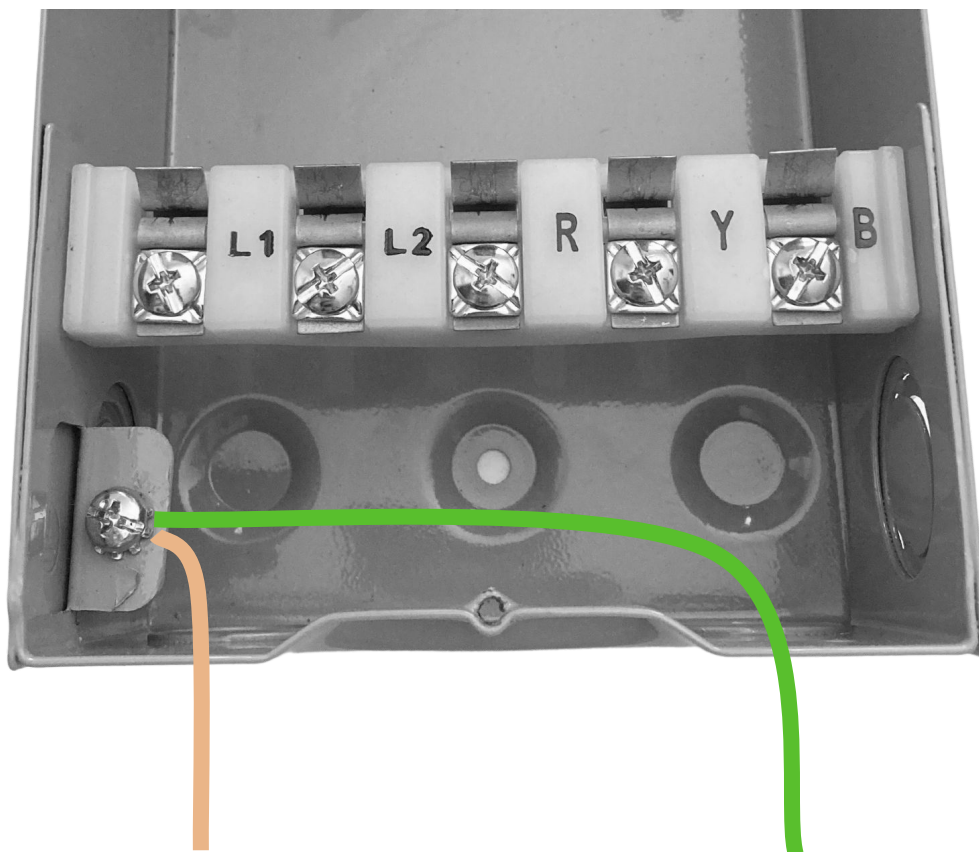

Bare Copper, Green,
or Green/ Yellow Conductor

Green Ground
from Pump Cable



Fork terminal



Step 7: Wire Starter Box

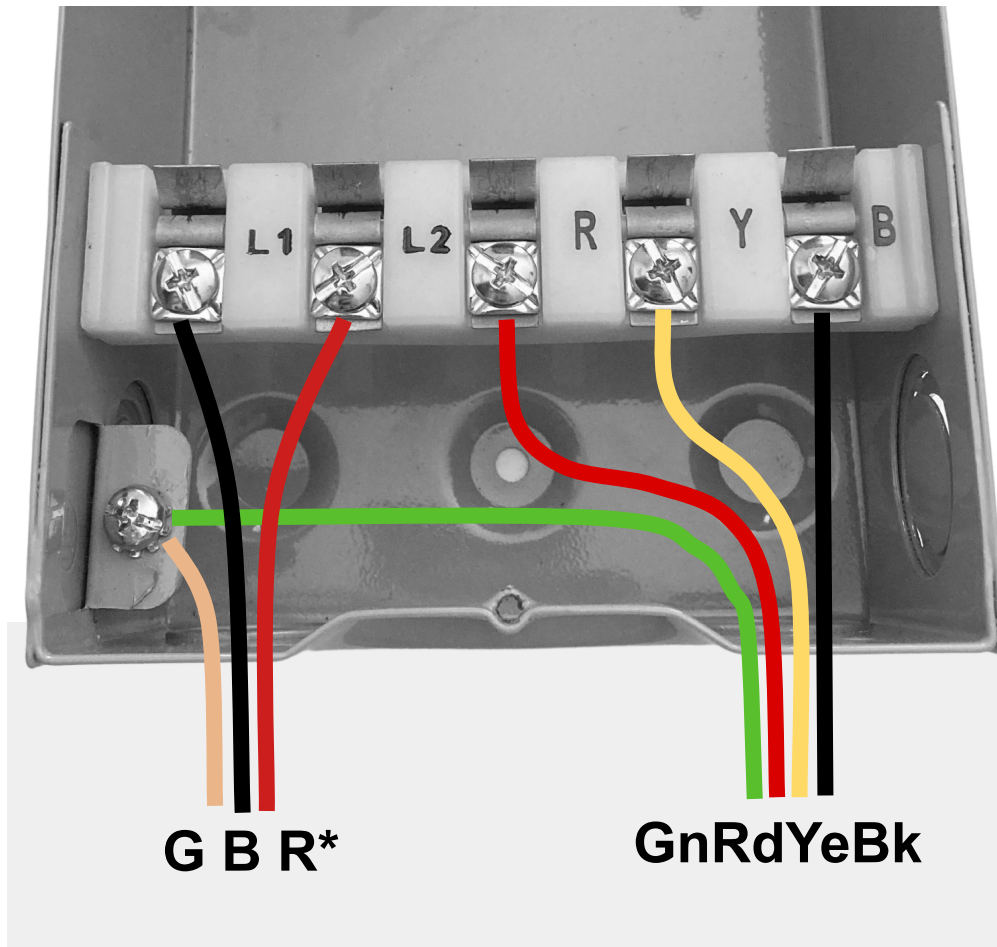

Line Input
(To Breaker /
Pressure Switch)

Pump Wire
(To Pump)

Connect the remaining the pump wires to their color indicated terminal label; R-Red,Y-Yellow, B-Black. Fork terminals are not necessary for these wires.

The remaining two strands from your line input cable should be wired to the L1 and L2 terminals. Polarity of wires does not matter here, only the 220V AC potential between Line 1 and Line 2.

*In 220V applications the second hot, depending on the wire type's appropriate environment, may be black, blue, red, or white.

Step 8: Wiring Pressure Switch + Wiring Fuse Box

WARNING - TURN OFF THE POWER AT THE BREAKER BOX BEFORE BEGINNING ANY WIRING. L1 and L2 conductors originating from the *starter box* will connect to the T1 and T2 terminal screws on the pressure switch, located on the inner left and inner right sides. Wires are interchangeable.

Incoming power from the *breaker box* will be connected to the outer terminals L1 and L2, wires are interchangeable.

Connect to your appropriately sized fuse in the breaker box.

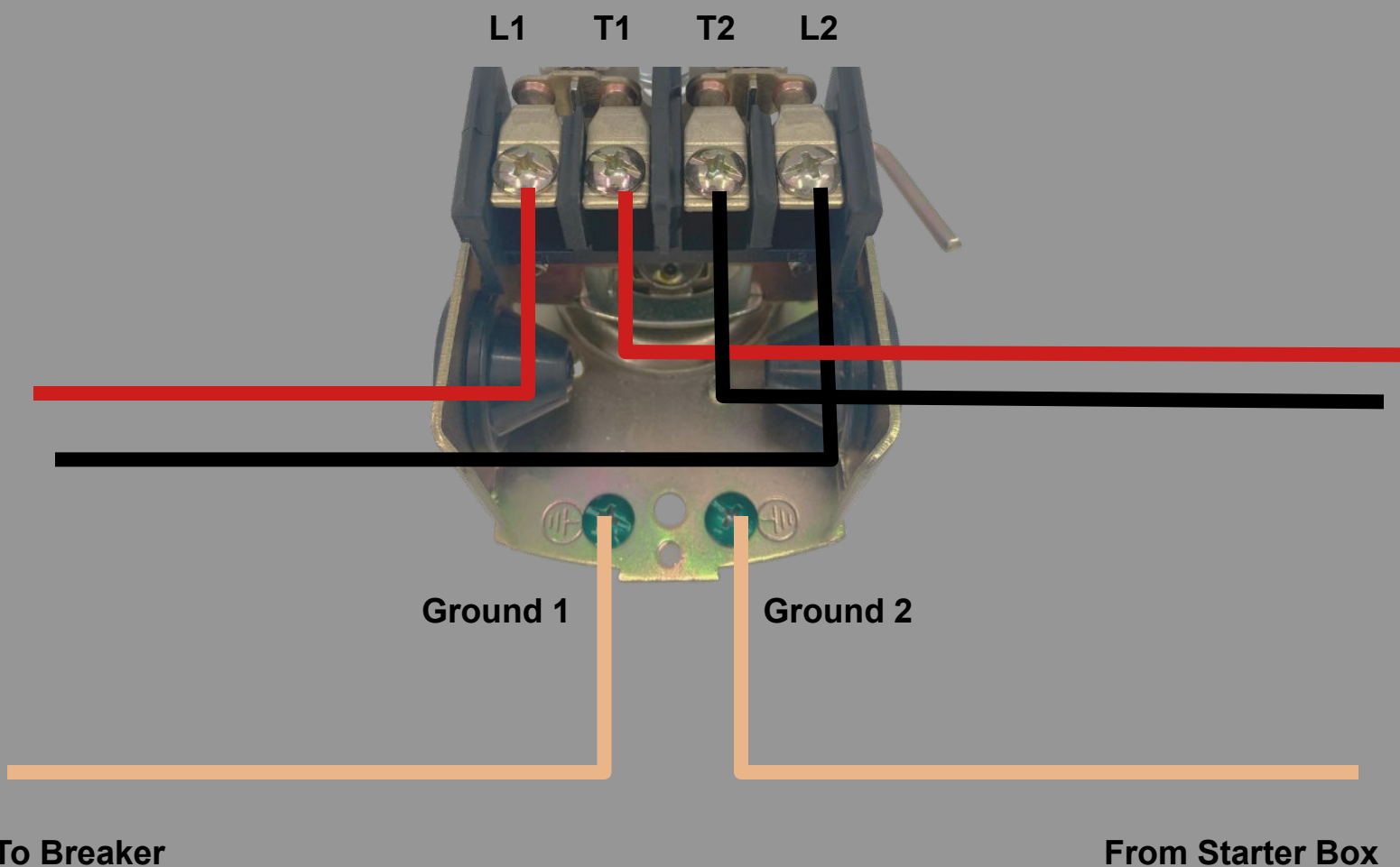

Installing a 220V Submersible Pump with a GFCI Outlet

Step 1: **Safety First** Before you begin, ensure that you turn off the power supply to the 220V outlet at your circuit breaker. This step is crucial to prevent electrical accidents during the installation.

Step 2: **Prepare the Pump Cable** Strip the ends of the pump wire.

Step 3: **Install a GFCI Outlet** in your desired location. Install the use the appropriate NEMA receptacle based the rating of your breaker (If your pump requires a 30 Amp breaker, use an outlet rated for 30 Amps as well, see page –). GFCI outlets protect against electrical shock and are highly recommended for outdoor installations. There are a WIDE variety of outlets that could be used for a 220V application, and the shape/orientation of the outlet changes based on the required circuit breaker rating. An L14-30(rated for 30 Amps) is most popular.

Step 4: Consult your local electrical code for restrictions on which option is best for your area.

Option #1 (recommended) Hardwire

- Attach the green or bare ground wire from the pump cable to the green screw on the GFCI outlet or to the ground terminal on the standard outlet (Ignored for L14)
- Connect the neutral wire(white, grey or red) from the pump cable to the silver or white terminal on the outlet.
- Connect the black hot wire from the pump cable to the brass or black terminal on the outlet.

Option #2 Plug Style Splice the pump wire from the submersible pump onto the pigtail from the 220V NEMA power cord (rated for your pump), matching up green to green, black to black. You can then plug the pump into a properly rated outlet. **CAUTION** this option can pose a tripping hazard.

Step 5: Secure the outlet in an appropriate electrical box, Before placing the submersible pump in water, turn the power back on at the circuit breaker. Lower the submersible pump into the well. Follow instructions on starting on page 23.



NEMA 6-20
20 Amp /
240V



NEMA 15-50
50 Amp /
240V



L14-30
30 Amp/ 240V



NEMA 6-15
30 Amp /
240V

Step 9: Piping

Pump plumbing (drop pipe)

Length

Most commonly, water well pumps are placed 20–30' below the water level. You may be able to set the pump even shallower if you know your well is a good producer and your water level won't decrease at your intended pumping rate. If your well has a very slow recharge rate, we recommend setting the pump as far as you can below the static water level (RPS Water Pumps submersible pumps can be placed a maximum of 600 feet below the water level).

Attempting to submerge the pump any deeper can damage your pump and void your warranty.

Diameter

Generally, 1 ¼ to 2" diameter is the most suitable size for drop pipe and accommodates the water volume of our systems, check without specialist if unsure what size pipe to use, or do a frictional loss calculation for your distance and GPM rate, that will decide the best pipe diameter.

Pressure rating

We recommend using poly pipe rated to 160 psi, for wells up to 300' (see diagram on page 7). Poly pipe is rigid-walled to prevent kinking as you work with it, but is not overly cumbersome. Poly pipe rated higher than 160 psi is acceptable as well up to 300', but keep in mind that it will be heavier and will require more heat to become malleable when connecting barbs and hose clamps (see below).

For installations past 300ft down to 450ft, 250PSI poly pipe can be used.

For installations 500ft+ it will be necessary to switch to SCH120 PVC or galvanized steel pipe.

Mixing Metal Plumbing Parts

We generally recommend using plumbing parts of like metals. For example, stainless steel with stainless steel, instead of connecting stainless steel to brass, which can cause corrosion over time and weaken connection points

A note about poly pipe

Historically, well pumps were installed using rigid pipe— first galvanized steel, which was heavy and difficult to work with, and then rigid PVC, which, while lighter and partially flexible, still needed to be screwed together in 20' lengths. The drawback of rigid pipe is that most of the time, a well owner needs a well pump professional or someone with a boom truck to pull their pump, leaving them beholden to a contractor to maintain, install, or replace their pump. Poly pipe, by contrast, can be installed easily by hand with one or two people depending on the depth of well; it's also lighter, doesn't corrode in water, and is suitable for drinking water. At RPS, we recommend poly pipe when possible because it ultimately gives you, the landowner, more control over your well.

PLUMBING & SAFETY LINE

At this point in the process it is important to prep a few items for later steps. If you take these extra steps in preparation you will thank yourself later.

Attach a safety rope through either of the two holes (or both) in the top of your pump. Polypropylene rope is best since it will not decay however you can use a chain or stainless-steel cable if desired.

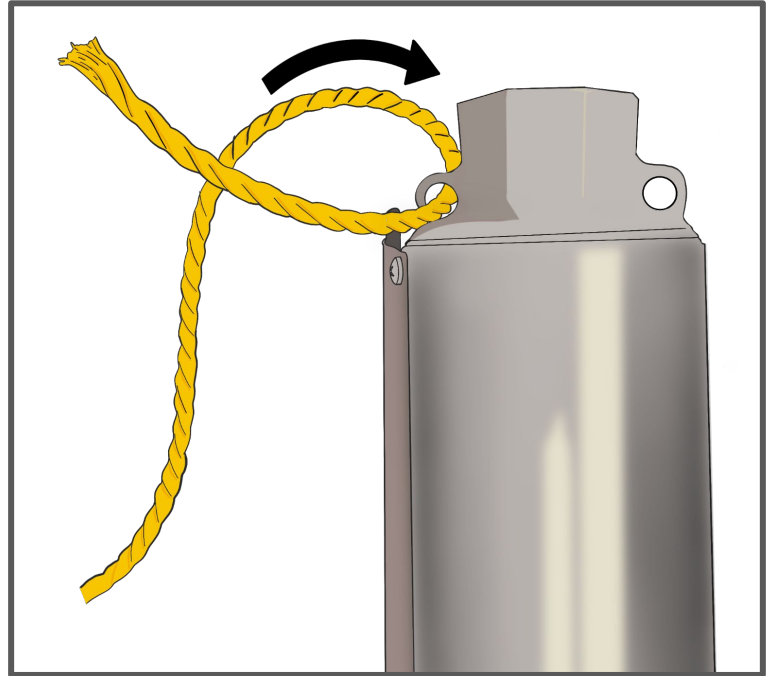

What you choose to use for the piping for your pump is completely up to you. We recommend poly pipe. If you are using poly pipe you are going to want to unspool the piping now and let it warm up. This step is especially important if the piping, or the surrounding weather is cold. Laying out the pipe now will make it so you don't have to fight against the pipes natural curvature while lowering down the pump.

After the pipe is laid out, run your heavy duty submersible flat jacket pump wire and your safety rope along the length of the pipe. Once this is done adhere the three lengths together using electrical tape and wrapping two to three times about every ten feet.

PRO TIP: Leave a little extra slack in the wiring and safety pop as polypipe can stretch up to 1% in the well. That's equal to 1 foot for every 100 feet of poly pipe.

90RPS, 150RPS, 230RPS and 300RPS Specific Instructions

There are three differences in the way these pumps are designed versus others

- 1) 3" outlet for high flow
- 2) 5.74" pump diameter, requiring at least a 6" well
- 3) And placement of safety rope

The 3" outlet matches with larger pipe, like Schedule 80 PVC, Schedule 120 PVC or galvanized steel pipe. The pipe can be directly threaded into the 3" FNPT outlet of the pump. RPS recommends using pipe dope to create a watertight and sturdy connection.



Safety Rope: Pipe that is 3" and above in size is very stable and doesn't experience fault issues, that's why our engineers say that safety rope is optional for these installs. If you still want a safety rope backup, then tie off the safety rope to the metal notch at the bottom of the pump end (see above). Tie off the safety rope at the top of the well as normal.



WELL PUMP PLUMBING WITH POLY PIPE

If your installation requires a check-valve, (for example installs that also have pressure systems, pressure tanks, irrigation etc) you will need to install all three of these plumbing pieces: a threaded nipple, a check-valve, and a hose barb, in that order.

Your RPS submersible pump already has an internal check-valve installed, but it is recommended to install a dedicated check valve when used in a pressure system and other installations where you want to ensure no leakage. You'll be attaching the threaded nipple FIRST to the outlet of your pump, then check valve, then hose barb.

For other open discharge applications you can install the hose barb directly to the outlet of your pump.

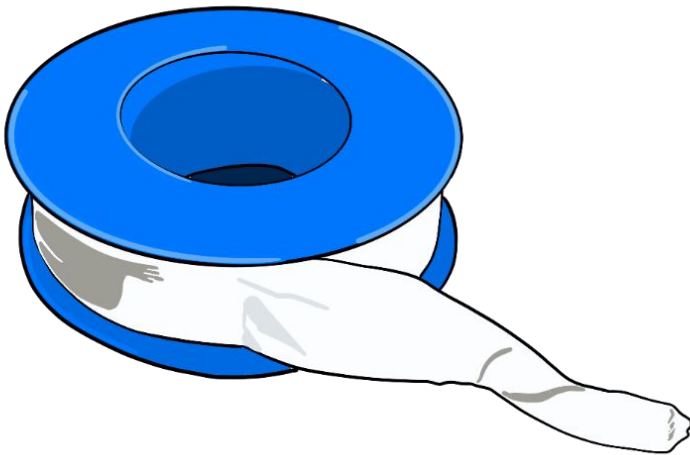

When installing any of the following plumbing pieces to your pump be sure to use 3+ wraps of teflon tape around the threads. Stainless steel can be more difficult to seal, so extra tape or pipe dope can help. Doing this will ensure that your fittings are secure and provide peace of mind.

PRO TIP: When wrapping teflon tape on any threads, wrap the tape going clockwise to avoid the tape being unraveled when threading on additional plumbing.

Connecting the pump to the drop pipe

Using a hose barb and Teflon tape, screw the male thread of the hose barb coupling into the female NPT pipe thread outlet of the pump. Thread the hose clamps over the pipe and out of the way, then insert the end of your poly pipe over the hose barb end of the coupling. In cold weather to make the tightest connections possible, apply even heat from a heat gun to warm up the poly pipe; this increases malleability and allows the pipe to fit snugly over the barb. While the poly pipe is warm, tighten the hose clamps over the poly pipe and barb.

Pro tip: use a socket set on the hose clamps instead of a screwdriver for a tighter fit.

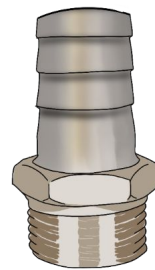

Hose
Barb

Optional

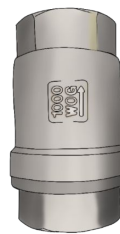

Check-valve

Make sure to install your check-valve with the arrow pointing with the flow of water (away from the pump.)



Threaded
Nipple

After you install your hose barb you will need to attach your piping, but first you will need to figure out what your outlet will look like. We recommend using a well seal assembly. A well seal is a metal assembly with three holes on the top. Under the face there is a rubber seal that will seal your well. Be sure to choose the right diameter well seal depending on the well casing size. This is measured from the inner diameter of your casing.

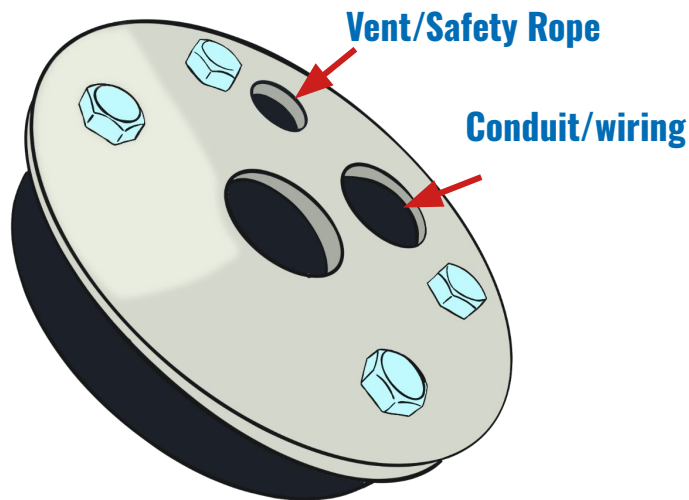

When you have your well seal you will want to put the assembly together. Start by putting the hose barb into the poly pipe and secure with three hose clamps alternating positions as pictured below.

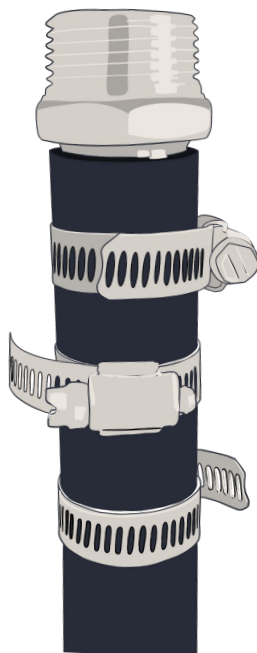

PRO TIP: it will be very difficult to push your piping down over your hose barb, this is by design. To make the process easier, especially in cold weather, use a heat gun or torch to heat the poly pipe slightly. The further down the hose barb you can get your pipe the better; however, it is not required to cover the entirety of the hose barb.

** In freezing climates it may be necessary to use a pitless adapter. In this case, the threaded barb will thread into the pitless adapter and be dropped into place deep in the well with your T Puller.

EXAMPLE OF WELL HEAD PLUMBING WITH POLY PIPE AND WELL SEAL

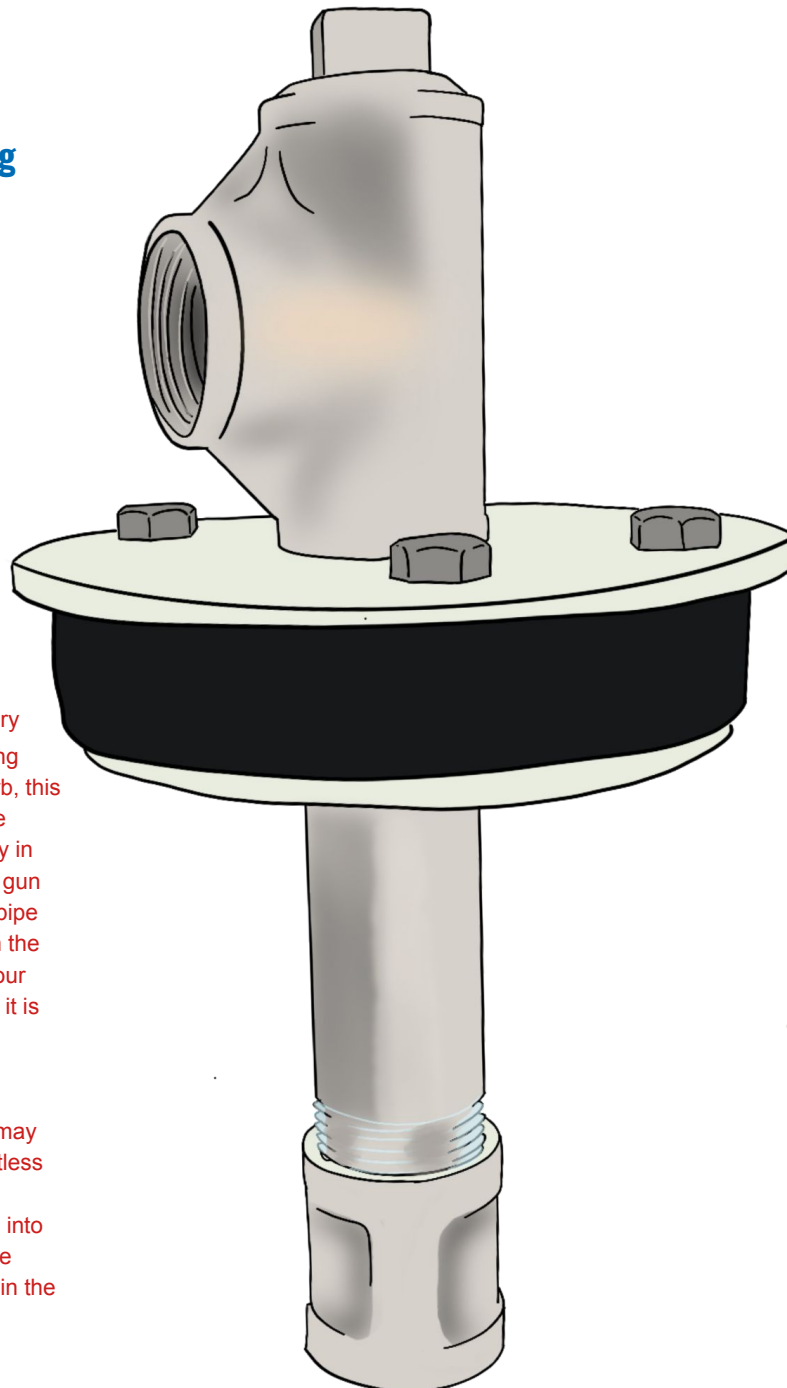

Step 9A: Pitless Adapter Option

For freeze prone areas, use a pitless adapter and well cap (instead of well seal). Drill a hole in the side of the well casing, locate the hole below your areas frost line.

Tools required:

Hole Saw Bit
Plumbers Tape and or Pipe Sealant
Extra Pipe Poly/PVC/ Steel Pipe
Cap for Extra pipe

Drill the hole in the side of your casing.

Place a piece of scrap PVC through the outlet of the pitless adapter. This will prevent the unit from falling apart and potentially losing a part down the well. Unscrew the nut, washer and seal that will go on the outside of the well. You'll be left with a nipple of pipe. Attach your extra pipe onto the top threaded outlet of Side A. Some people like to thread on a handle bar at the top of the pipe for install which they remove later, capping the pipe. Lower the Pitless adapter down into the well and sight it with the hole you drilled. Push the pitless adapter through the hole, and reattach the seal, washer and nut, using some pipe sealant on the threads for the nut. Remove the scrap PVC. Seal off the top of your well pipe. Install your well cap.

A pitless adapter easily slides a-part, pull and apply some lift on the pipe near the top of the well and you're left with two pieces, A and B. This is how you'll be able to pull the pump from your well without having to remove the entire pitless adapter assembly.

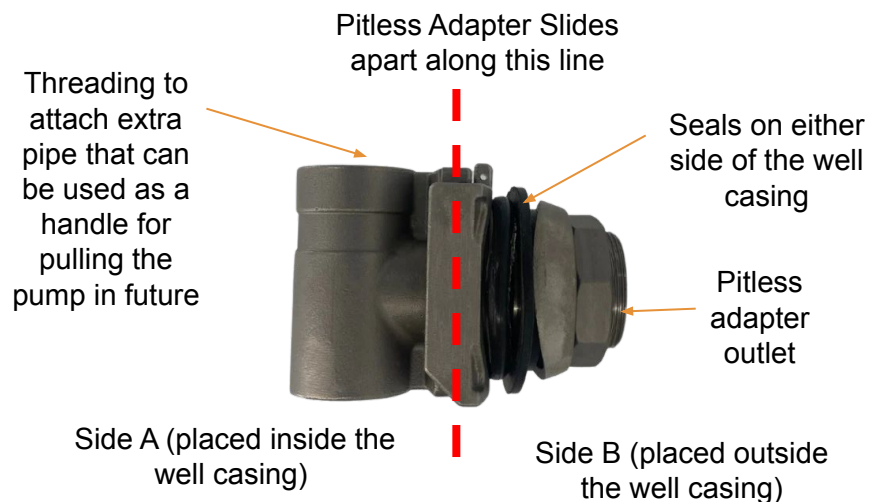
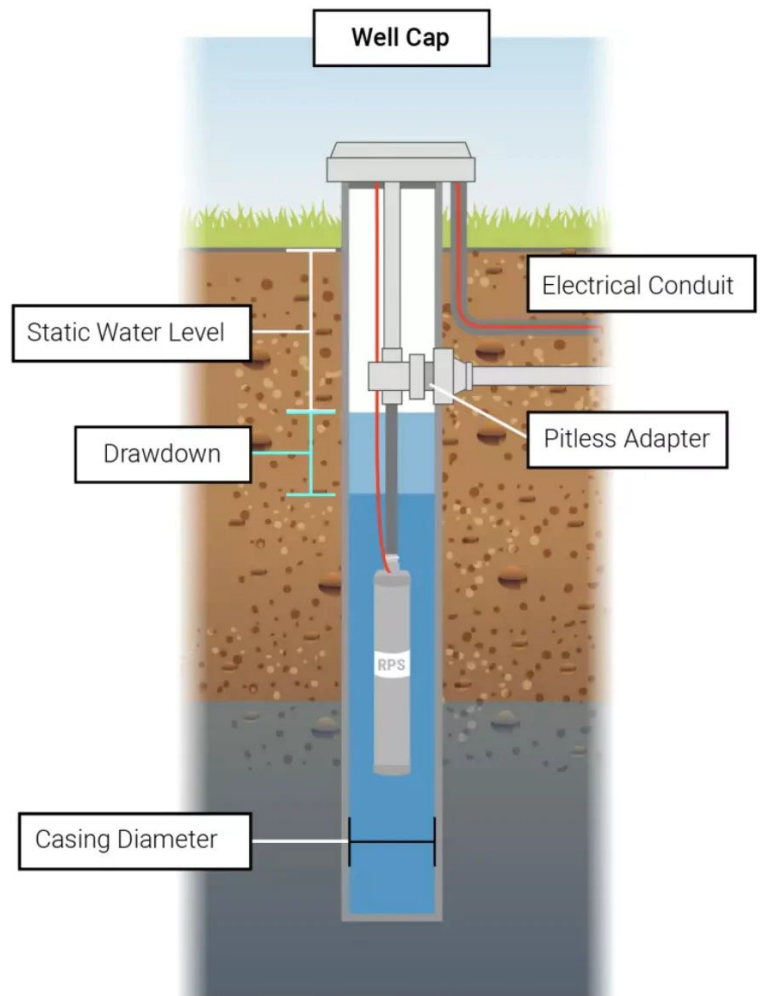

Diagram 2: Installing Via Well Seal + Pressure Tank

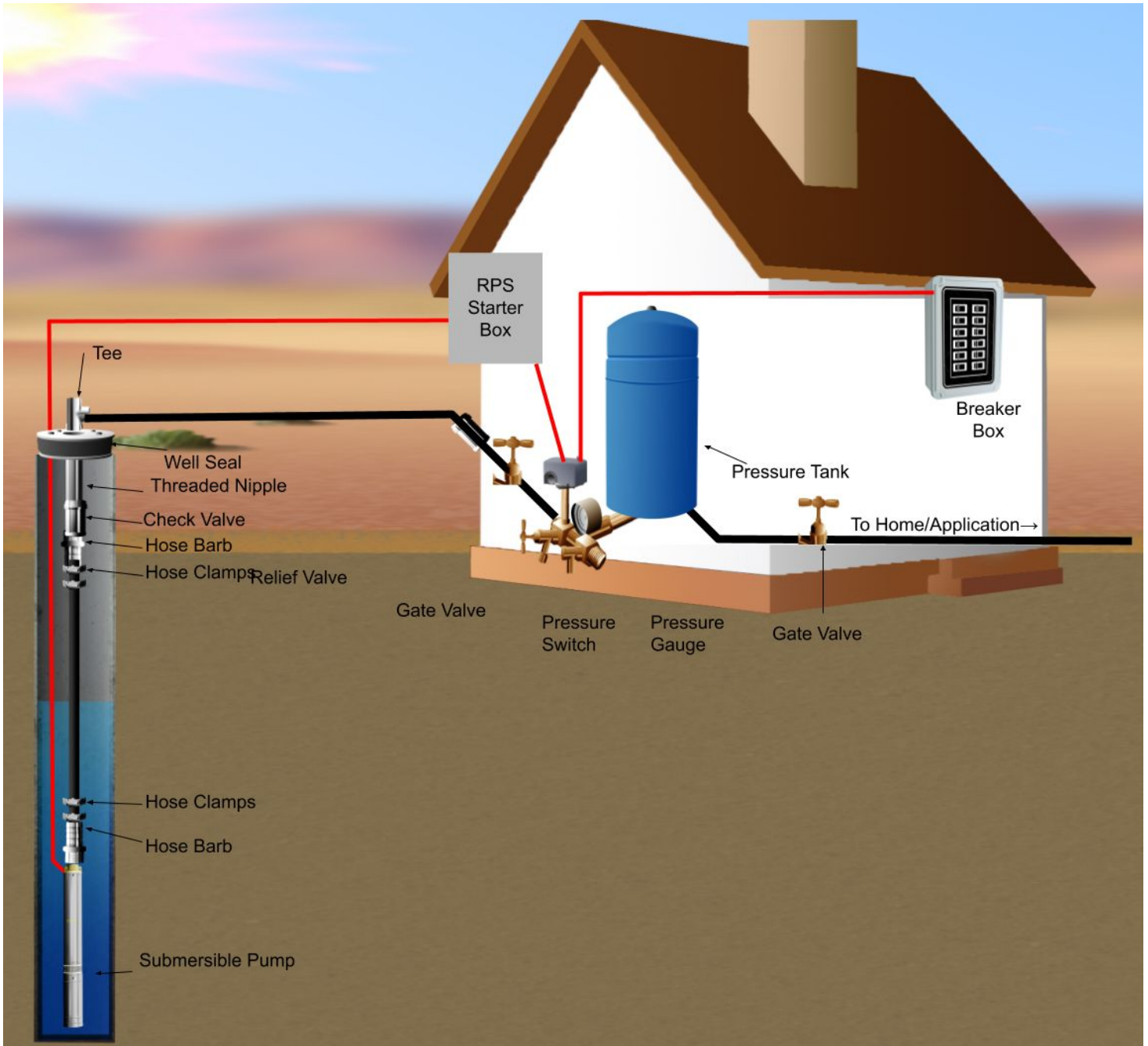
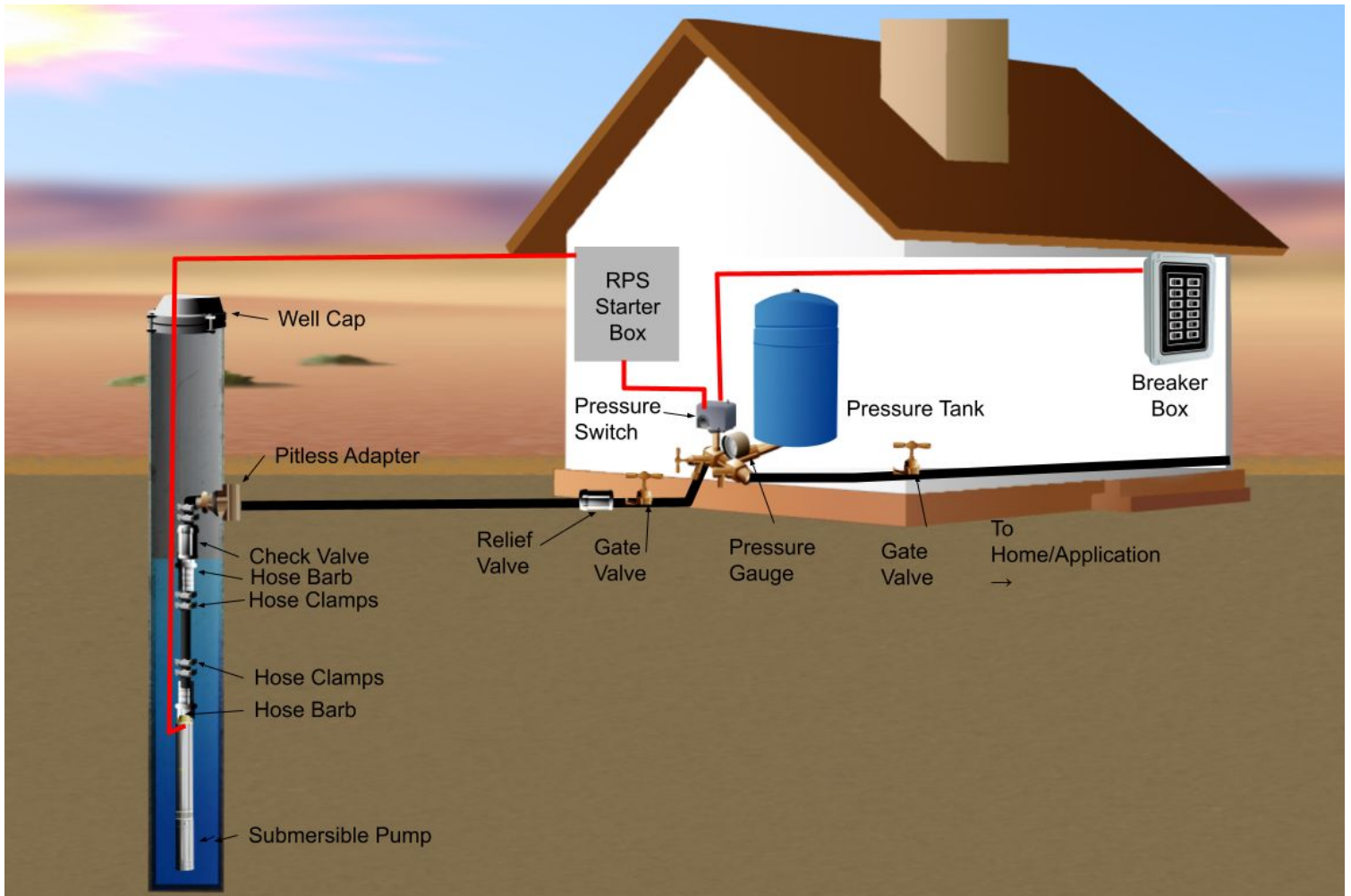

Diagram 1: Installing with a Pitless Adapter + Pressure Tank



Step 10: Above Ground Bucket Test

Using a bucket of water, or some container of water large enough to submerge the entire intake are of the pump, turn the pump on and check for proper operation before installing downwell.

STEP 1

Fill a large receptacle (water tank, garbage can, or tote will work) with fresh clean water.

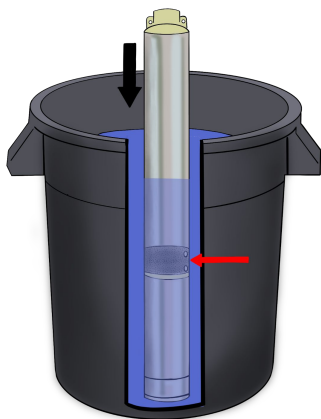

STEP 2

Place your pump into the receptacle. **Ensure that the water level is ABOVE the center of your pump where the inlet is located.**

STEP 3

After ensuring your pump is connected to the controller and submerged in the water, provide power to your controller. The system will automatically start when you connect your controller to your AC power source.



Step 11: Final Installation

CHECKLIST: Are you ready to lower your pump?

Remember, **DO NOT** turn on the pump unless it's completely under water!

- You've read the manual and all the KEY STEPS in each section.
- Pipe connected to pump with barb and hose clamps (or double check PVC/ steel connections)
- Length of drop pipe appropriate for setting pump. Don't rest the pump on the bottom of the well to avoid stirring up silt and sand.
- Safety rope attached directly to pump.
- Pipe, wires, and rope electrical taped together every 10–20'. Be sure to leave a few inches of slack in both wires to allow for the poly pipe to stretch a little on install.
- Pump wire connected to R, Y, B and ground terminals.
- Tested successfully in a bucket! **We highly recommend this step with deep wells, rigid plumbing, and when the R,Y,B wires may have gotten mixed up during splicing or final connections!**

We estimate that hand lowering a submersible pump is doable for wells up to 300-400 feet. Past that, the parts become too heavy and cumbersome to lower by hand. Some customers use a small rig off the back of their truck, or for deep wells, hire a local well pump installer with a heavy duty truck rig.

When you begin to lower the pump, **DO NOT** rest the pump wire on the side of the well casing, and ensure that as you lower the pipe wire isn't scraping against the well casing entry. If the pump wire is scraped or damaged, water will leak into the wires - damaging the wires and interrupting operation.

Once lowered turn on!

Using a Generator with an AC Pump

HP Rating, 3 Wire Single Phase	Minimum Generator Rating kW
½ HP	2 kW
¾ HP	3 kW
1 HP	4 kW
1 ½ HP	5 kW
2 HP	7.5 kW
3 HP	10 kW
5 HP	15 kW

How to Wire in a Generator for Operation

Refer to the diagram on page 18 of the pressure switch wiring. Remove the L1 and L2 wires that connect with your breaker box.

If connecting a generator, the most common 220V receptacle is a NEMA L14-30R which is a twist lock 4 prong receptacle. This receptacle receives the corresponding L14-30P plug. There is no neutral line needed, so this wire can be cut off or capped if present, leaving Ground, Line 1, and Line 2 for the connection.

The ground prong can be uniquely identified by its 90° bend and is usually green. The neutral is located on the opposite side of the ground and is often identified by a bright silver terminal screw. Line 1 and Line 2 are adjacent to the ground prong and typically have brass terminal screws on the plug.



Troubleshooting

The Problem you're experiencing...	Probable Cause...	Recommended Action...
Pump won't start (and electrical fuses do not blow)	Insufficient voltage at starter box	Check voltage at starter box. Check connections and rewire if necessary from fuse box to starter box.
	Insufficient voltage at fuse box	Issue with power supplier for fuse box. Or check generator
	Installed at inappropriate depth	Check the depth to which you installed the pump, may be set too deep for pump ability range
	Pump wire or splice bad	Its possible the splice was not sealed correctly and water seeped into the wire connections. Or the connections themselves were not made properly/are loose
	Starter box wired incorrectly	Check wiring diagrams and re-wire
	No Voltage at pressure switch	Check connections and re-wire from starter box
Pump starts but fuses blow/overload trips when motor turns on	Wrong size fuse (usually due to insufficient rating for HP)	Turn off power and Install correct fuse or time delay fuse
	Small Wire gauge	Check wire gauge and install correct wire size

The Problem you're experiencing...	Probable Cause...	Recommended Action...
<p>Pump starts but fuses blow/overload trips when motor turns on</p>	<p>Pump or motor locked up / stuck</p>	<p>Pull pump if necessary, attempt to remove debris if that's the issue. Alternatively, replace the locked up pump. Clean well of sand before reinstalling.</p>
	<p>Broken wire</p>	<p>Check starter box and connections for faulty wire, replace.</p>
	<p>Pump cables incorrectly wired</p>	<p>Check starter box connections for correct connections, rewire for color coding.</p>
	<p>Low voltage or high voltage</p>	<p>Check with voltmeter if the line voltage into the breaker from the power company is within 10% of rated variation</p>
	<p>Starting capacitor bad</p>	<p>Check starter box for blown capacitor, replace.</p>



The Problem you're experiencing...	Probable Cause...	Recommended Action...
Pump not producing enough flow GPM	Check valve faulty, installed backwards or clogged	Inspect check valve and reinstall or replace
	Low water level OR pump not fully submerged	<p>The pump is either too close to the surface of the water and needs to be installed deeper (pump inlet should be at least a few feet below water level), or pump may be outpacing well GPM recovery rate Install at least 5 feet off the bottom of the well.</p> <p>Check drawdown of well. Throttle back discharge valve to decrease water flow from pump, check drawdown again to confirm pump production is not outpacing well production.</p>
	Clogged intake screen	Pull pump and clean screen
	Low voltage	While pump is turned on and running, check voltage at starter box. Check wire size connecting fuse box to start box, and pump wire gauge running to pump. Install larger wire gauge to accommodate voltage, possible need for raise in supply voltage.
	Leaks in pipe or fittings	Check above ground fittings first for tightness. Pull pump and check installed fittings and piping. Repair and leaks.
	Shaft turning wrong direction (3 Phase motors only)	Reverse any two electrical wires at the starter box.

The Problem you're experiencing...	Probable Cause...	Recommended Action...
<p>Pump not producing enough flow GPM</p>	<p>Impellers clogged by foreign matter</p>	<p>This test applies for clogged intake screen and leak in fittings as well, install a pressure gauge near the discharge port, turn on the pump and then slowly close the discharge port. Take a look at the pressure at shutoff and write down the PSI. Don't let the pump run long at shutoff, this could damage the equipment.</p> <p>Next, convert the PSI number you wrote down to feet of head using this equation...</p> <p>PSI x 2.31 feet = “ “ feet of head</p> <p>Then, add that number with the number of feet down to the pump in the well.</p> <p>That number should add up to a point on the pump curve for your pump model. Your pump model has a shut off head, the point close to the upper left hand of the pump curve. If the calculated number you received is below that shutoff number, then the pump itself is probably ok and not the issue. If not, then pull the pump to inspect.</p>
	<p>Worn out impellers / excessive pump wear</p>	<p>This might happen for older pumps or pumps in water with high dissolved solids or sand. Ensure that impellers are clear of obstructions, replace pump if</p>



The Problem you're experiencing...	Probable Cause...	Recommended Action...
Fuses blow / overload protectors trip during normal operation	Low or high voltage	Check with voltmeter if the line voltage into the breaker from the power company is within 10% of rated variation
	Starter box overheating	Mount starter box in a shady area
	Wrong control box, control box not rated for HP	Check model numbers match with each other, replace if necessary
	Wrong wire size	Wire size too small for application, reinstall proper wire size
	Cable splices or pump wire ground shorted	Consult electrician
Pump starting frequently	Leaks!	Check all plumbing and tank connections, should be airtight, add teflon tape.
	Issue with pressure switch	Defective switch, or just re-adjust the pressure switch settings
	Pressure tank leaky	Check for leak in bladder of pressure tank, make sure set to 2 PSI less than the cut in pressure. Replace bladder if necessary.
	Drop pipe leak	Plug leak in drop pipe, or replace pipe at leak and above
	Pressure switch too far from tank	Move pressure switch within 5 feet of pressure tank

TERMS & CONDITIONS

These Terms and Conditions (“Terms”) are entered into by and between you and Rural Power Systems Inc. dba RPS Water Pumps, and apply to any products purchased from RPS Water Pumps (“RPS Products”) and related services provided through our website (“Services”). BY PURCHASING OR USING RPS PRODUCTS and/or SERVICES YOU ACCEPT AND AGREE TO BE BOUND BY THESE TERMS, AND OUR PRIVACY POLICY. If you do not want to agree to these Terms or the Privacy Policy, you must not purchase any RPS Products or Services

CHANGES TO THE TERMS

We may revise and update these Terms from time to time in our sole discretion. All changes are effective immediately when we post them on our Website (www.rpswaterpumps.com), and apply to all purchases of RPS Products and all access to and use of the Services thereafter.

Your purchase of RPS Products and continued use of the Services following the posting of revised Terms means that you accept and agree to the changes. You are expected to check this page from time to time so you are aware of any changes, as they are binding on you.

PRODUCT INFORMATION

All RPS Product descriptions, prices, and availability are subject to change without notice. We also reserve the right to limit the quantities of any Products or Services that we offer, and to refuse service to anyone for any reason at any time.

DIY INSTALLATION WARNING; ASSUMPTION OF RISK

RPS Water Pumps (“RPS Products”) come with an easy to install Do-It-Yourself (“DIY”) kit intended for the consumer to install themselves or with the help of others. **THE RISK OF INJURY AND ELECTRIC SHOCK EXISTS AND COULD RESULT IN SERIOUS BODILY INJURY OR DEATH. You are the best judge of your own capacity and qualifications to determine whether you can install the RPS Products or if you require assistance. Only qualified persons should install the products. Turn off power before installing. By purchasing an RPS Product, you acknowledge the potential risks and agree to assume all such risks of injury, including death.** In some cases, you may decide to hire a professional to complete some or all of the installation. Whether self-installed or professionally installed, RPS Water Pumps is unable to guarantee or offer any compensation for troubleshooting, replacing parts, pulling pumps or anything else involved in the troubleshooting/replacement process, regardless of the reason for the warranty claim. But never fear, RPS Water Pumps has tens of thousands of customers across the USA who have successfully installed and, in those rare cases, troubleshoot their system with the help of our dedicated RPS Water Pumps support engineers!



ORDERING AND PAYMENT

When you place an order on our Website, you agree to pay for the RPS Products and any applicable shipping and handling fees. We accept payment by credit card, debit card, and PayPal, and all payments are processed securely through a third-party payment processor.

Your order confirmation email is not a guarantee that we have the product in stock or that we will be able to ship the product to you. We reserve the right to cancel any order at any time and for any reason.

The information for all orders placed on our Website is encrypted using industry standard SSL technology. We do not store your credit card information on our servers.

PROCESSING, SHIPPING AND DELIVERY

We make every attempt to ship the same day the order is received. Sometimes, this is not possible, and the items will ship the following day or days.

We also utilize flat rate USPS boxes to try to keep shipping costs down on a case-by-case basis. We charge flat rate shipping based on the products weight and size. If you have a preferred third-party shipping service, please provide this preference with your billing details during the checkout process.

Due to popularity, some of our items require a bit of extra time to ship. This will be noted on the product page along with an estimated shipping lead time. Please contact us if you have any concerns, and we will try our best to accommodate your specific needs and communicate throughout.

We will ship your order to the shipping address provided by you during the checkout process. Shipping times and delivery dates are estimates only and are not guaranteed. You are responsible for any customs duties, taxes, or fees that may be charged by your area or country. We are not responsible for any delays or damages caused by the shipping carrier.

Title and risk of loss of the RPS Products will pass to the customer upon delivery of possession of the RPS Products by RPS Water Pumps to the carrier, subject to stoppage of RPS Products in transit.

RETURNS AND REFUNDS

Customer shall inspect the RPS Product within 30 days of receipt and will be deemed to have accepted the RPS Product unless you notify RPS Water Pumps of your intent to return the product. You may return the RPS Products purchased, for any reason, for a full refund up to thirty (30) days after the date of purchase. The RPS Products must be **unused**, in new condition, and you must pay the return shipping or return to product to RPS Water Pumps in person. For your convenience, we are happy to email printable shipping labels and deduct the cost (often a discounted rate vs. retail store rate) from your refund amount.

After 30 days and up to sixty (60) days after purchase, a full refund is not available, but transferrable store credit is available for returned products. Unfortunately, we do not accept returns past 60 days and are unable to offer refunds, however, your product warranty is transferable in event the system is sold during the Warranty Period.

As a condition of this return policy, you agree to give us the opportunity to troubleshoot the issue(s) with the RPS Product to work out any issues prior to return.

We have created an extensive help section of the user manual (www.rpswaterpumps.com/help) and we have an incredible team that can help work out any issues over the phone, text or email at [\(530\) 240-3825](tel:5302403825) and service@ruralpowersystems.com

PRODUCT WARRANTY

2-Year System Warranty:

Rural Power Systems Inc. (RPS Water Pumps) warrants to the owner for a period of twenty-four (24) months from the date of purchase (“Warranty Period”) such RPS Products will be free from material defects in material and workmanship. During the Warranty Period, RPS Water Pumps will repair or replace any defective part(s) at no cost to the owner.

During the Warranty Period, in the event of a malfunction, the purchaser must return the defective product to receive a replacement. The warranty is limited to the repair or replacement of the defective product purchased from RPS Water Pumps. **YOUR USE OF THE SERVICES AND RPS PRODUCTS IS AT YOUR OWN RISK. RPS WATER PUMPS DISCLAIMS ALL WARRANTIES UNLESS EXPRESSLY PROVIDED IN THESE TERMS, INCLUDING BUT NOT LIMITED TO ANY WARRANTIES OF MERCHANTABILITY, NON-INFRINGEMENT, AND FITNESS FOR A PARTICULAR PURPOSE.** The above remedies shall be the sole and exclusive remedies and RPS Water Pumps’ sole liability for any breach of the limited warranty set forth above.

This warranty does not apply when the RPS Product has not been installed according to the instructions or damage has occurred through abuse, carelessness, negligence, improper installation, connecting to an improper voltage (most commonly, connecting too many panels in series for your controller) or degraded wells. Your warranty is linked to your product’s serial number, which is on record at RPS Water Pumps. RPS Water Pumps will quote all replacements not covered by warranty or outside the warranty period.

For a complete list of other available warranties and guarantees visit:

www.rpswaterpumps.com/terms/

Instant Replacement Program

We understand that time is money, which is why we offer an instant replacement program. If warranty return of a part is required, we will ship the replacement part immediately while the defective part is in transit to be returned. We require a credit card number to ensure the defective part is returned and to prevent fraud. We place a temporary hold on your card, but if the defective part is returned, there will be no charges to your credit card.

Non-Warranty Replacement

There are occasions when replacement parts will be required past the 2-year warranty period. In these cases, please feel free to contact us for information on individual parts or units. We will work with you to get your system back up and running. In addition to replacement parts, we have like-new parts and systems for sale at discount prices. Contact us for more information.



Water Assurance Guarantee:

We offer a money back guarantee that our pump systems will provide you water when sized by one of our engineers to your well, desired setup and final total dynamic pumping head. We do require static water levels, drawdown and pressure requirements are accurately estimated during the sizing process, that installation follows the instructions of the RPS User Manual, and that you give RPS engineers a chance to troubleshoot any issues.

LIMITATION OF LIABILITY

TO THE MAXIMUM EXTENT PERMITTED BY APPLICABLE LAW, IN NO EVENT SHALL RPS Water PUMPS BE LIABLE FOR ANY CONSEQUENTIAL, INDIRECT, INCIDENTAL, SPECIAL, EXEMPLARY, PUNITIVE, OR ENHANCED DAMAGES, LOST PROFITS OR REVENUES OR DIMINUTION IN VALUE, ARISING OUT OF, OR RELATING TO, AND/OR IN CONNECTION WITH ANY BREACH OF THIS AGREEMENT, REGARDLESS OF (A) WHETHER SUCH DAMAGES WERE FORESEEABLE, (B) WHETHER OR NOT RPS WATER PUMPS WAS ADVISED OF THE POSSIBILITY OF SUCH DAMAGES, (C) THE LEGAL OR EQUITABLE THEORY (CONTRACT, TORT OR OTHERWISE) UPON WHICH THE CLAIM IS BASED, AND (D) THE FAILURE OF ANY AGREED OR OTHER REMEDY OF ITS ESSENTIAL PURPOSE.

IN NO EVENT SHALL RPS WATER PUMPS' AGGREGATE LIABILITY ARISING OUT OF OR RELATED TO THIS AGREEMENT OF THE RPS PRODUCTS, EXCEED THE TOTAL OF THE AMOUNTS PAID TO RPS WATER PUMPS FOR THE PRODUCTS PURCHASED BY CUSTOMER.

INDEMNIFICATION

Customer shall indemnify, defend and hold harmless RPS Water Pumps and its officers, directors, employees, agents, affiliates, successors and permitted assigns (collectively, "Indemnified Party") against any and all losses, damages, liabilities, deficiencies, claims, actions, judgments, settlements, interest, awards, penalties, fines, costs, or expenses of whatever kind, including reasonable attorneys' fees, fees and the costs of enforcing any right to indemnification under this Agreement, incurred by Indemnified Party relating to any claim of a third party arising out of or occurring in connection with the RPS Products purchased from RPS Water Pumps or Customer's negligence, willful misconduct or breach of this Agreement. Customer shall not enter into any settlement without RPS Water Pumps' or Indemnified Party's prior written consent.

INTELLECTUAL PROPERTY

All intellectual property rights of RPS materials and content on the Website, including but not limited to text, designs, images, graphics, logos, and software, is the property of RPS Water Pumps or its licensors and is protected by US intellectual property laws. You may not use any of our intellectual property without our prior written permission.

WEBSITE TERMS

Website Content. The information presented on or through the Website is made available solely for general information purposes. We do not warrant the accuracy, completeness or usefulness of this information. Any reliance you place on such information is strictly at your own risk.

WITHOUT LIMITING THE FOREGOING, RPS Water PUMPS DOES NOT REPRESENT OR WARRANT THAT THE SERVICES OR CONTENT WILL BE ACCURATE, RELIABLE, ERROR-FREE OR UNINTERRUPTED, THAT DEFECTS WILL BE CORRECTED, THAT OUR WEBSITE OR THE SERVER THAT MAKES IT AVAILABLE ARE FREE OF VIRUSES OR OTHER HARMFUL COMPONENTS OR THAT THE SERVICES OR ITS CONTENT WILL OTHERWISE MEET YOUR NEEDS OR EXPECTATIONS.

We may update the content available through the Services from time to time, but its content is not necessarily complete or up-to-date. Any of the material available through the Services may be out of date at any given time, and we are under no obligation to update such material. From time to time, RPS Water Pumps may issue an update to the Services, which may add, modify, and/or remove features; these updates may be pushed out automatically with little or no notice.

Users Outside the United States. The owner of the Website is based in the state of California in the United States. We make no claims that the Services or any of its content is accessible or appropriate outside of the United States. Access to the Website may not be legal by certain persons or in certain countries. If you access the Website from outside the United States, you do so on your own initiative and are responsible for compliance with local laws.

Privacy Policy. All information we collect through the Services is subject to our *Privacy Policy* RPSwaterpumps.com/terms/. By visiting the Website and using the Services, you consent to all actions taken by us with respect to your information in compliance with the Privacy Policy.

Copyright Infringement. We take claims of copyright infringement seriously. We will respond to notices of alleged copyright infringement that comply with applicable law. If you believe any materials accessible on or from the Services (including the Website) infringe your copyright, you may request removal of those materials (or access to them) from the Services by submitting written notification to us at copyright@ruralpowersystems.com.

Feedback. To the extent that you give us feedback, comments or suggestions concerning the Services (collectively, "**Feedback**"), you acknowledge and agree that all Feedback is RPS Water Pumps' sole and exclusive property, and you hereby unconditionally and irrevocably assign and transfer to RPS Water Pumps, your entire right, title and interest in and to any intellectual property rights that you may now or hereafter have in or relating to the Services. To the extent that the foregoing assignment is ineffective for whatever reason, you agree to grant and hereby grant to RPS Water Pumps a non-exclusive, perpetual, irrevocable, royalty-free, worldwide license (with the right to grant and authorize sublicenses) to make, have made, use, import, offer for sale, sell, reproduce, distribute, modify, adapt, prepare derivative works of, display, perform, and otherwise exploit such Feedback without restriction. At our request and expense, you will execute documents and take such further acts as we may reasonably request to assist us in acquiring, perfecting and maintaining our intellectual property rights in, and other legal protections for, the Feedback.



NOTES

NOTES

NOTES



RPS
WATER PUMPS

RPS | Rural Power Systems
40250 County Road 27
Woodland, CA 95776