

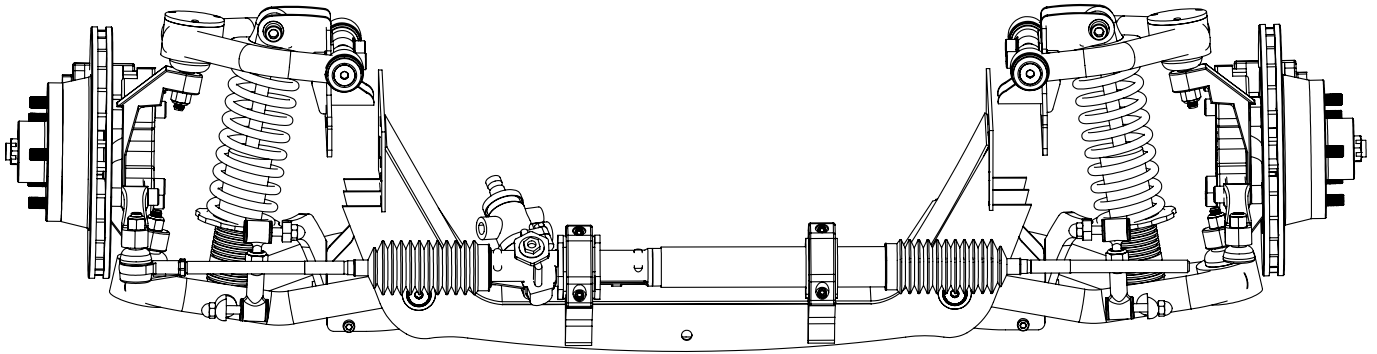

MAGNUM IFS
ENGINEERED BY DESIGN



Specifications:

USS-IFS-144GT / USS-IFS-144GS (1948 - 52 Ford F1 retrofit units)

Crossmember: 4mm mild steel TIG welded construction

Top control arms: 31.8mm/3.0mm wall CDS CNC bent

Lower control arms: 38.1mm/3.0mm wall CDS CNC bent

Hub to hub width: 1450mm

Suspension travel: 140mm total travel at wheel

Total weight: 89.25kg

Steering rack ratio: 42.1:1 (mm/turn)

Turns lock to lock: 3.25

Caster: Adjustable 0 to -5 degrees

Camber: Shim plate adjustable

(0.5-1.0 degree negative at ride height recommended)

Anti-dive: 4 degrees built-in

Brake rotor diameter (standard): 287mm

Brake calipers: BAER S4

Coilovers / Shockwaves: QA-1 Alumamatic / Ridetech

Lateral Control: 25mm anti-roll bar with LFX oil filled nylon bushes