

# SENATOR™ SILENT 345



**5000**  
PSI

**16**  
L/PM

**KOHLER KD1903**  
**42HP**  
**DIESEL**  
**ENGINE TYPE**  
KOHLER Diesel

**DIRECT**  
**1500RPM**  
**DRIVE**

**COLD**  
**WATER**  
**OUTPUT**



## HERO INNOVATIONS



**PEXO™**  
Enclosed Design



**JWPP™**  
Jetwave Italian Premium Pump



**INTELIUMS™**  
LCD Control System



**OLCE™**  
Oversized Liquid Cooled Engine



**ULDO™**  
Ultra Low Decibel Output

LEARN MORE



Senator Silent Video

## APPLICATIONS



Tradesmen



Factories & Manufacturing



Mine Sites



Offshore Oil & Gas



## STANDOUT FEATURES



JW® Enhanced Italian triplex plunger pump running at 1500RPM delivers more performance and longer life.



Oversized Liquid Cooled Kohler™ KD1903 42HP diesel engine that optimises all speeds and loads.



InteliumS™ LCD Unit management system displays live data read outs, warnings and auto shutdown to protect the units critical components.



Sound proof cabinet ensures ultra low noise emissions approx 70dB allowing after hours cleaning in built up areas



Enclosed steel cabinet protection keeps all critical working components safe from weather and operator error.



Battery isolator & emergency stop.

## STANDARD EQUIPMENT



Industrial spray gun & single lance.



15m Double Wire Braid Hose with M22 Couplings.

## DIMENSIONS (MM)

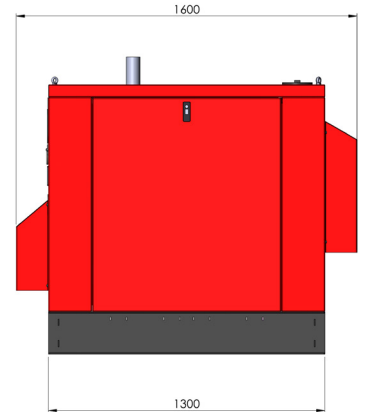
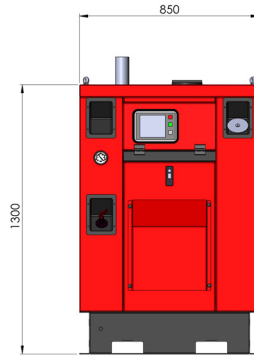

## TECHNICAL DATA 0:00

## SENATOR™ SILENT 345

Product Code	CW5000-16DI
Pressure / Flow Rate	5000 PSI (345 BAR) / 16 L/PM
Max Water Inlet Temp	60°C
Class (ASNZS: 4223)	Class A (5,520 Bar/Litres)
Usage Frequency	Industrial: 6 - 8 Hours Daily
Nozzle Size	O55
Frame Structure	CNC Modular skid galvanised steel chassis plus satin powder coat finish w/removable side covers

## MOTOR FEATURES

Engine / Power	Kohler™ KDI1903 Electric Push Button Start (liquid cooled) 42HP / 1861cc
Fuel Type / Capacity / Protection	Diesel / 80L / IntelliUMS™ Auto Shutdown Protection

## HYDRAULIC FEATURES

Pump / Head / Pistons	JW® Italian Triplex Plunger / Brass (Nickle Plated) / Ceramic
Motor Pump Coupling / Pump RPM	Direct Soft Coupling / 1500RPM
Unloader Valve	Independent
Safety Valve	Yes

## DIMENSIONS & WEIGHT

Machine Dimensions / Weight	Skid: 1600mm(L) x 850mm(W) x 1300mm(H) / 530KG
-----------------------------	--

## WARRANTY(S)

Unit / Pump Warranty*	2 Years
Engine Warranty*	<b>KOHLER</b> .Diesel 3 Years

## OPTIONAL ACCESSORIES

## OPTIONAL UPGRADES

A-Frame Hose Reel 100m	JWA120	4 x LED Work Lights + LED Beacon	JWA427
Additional High Pressure Hose	52001	Mine Specification Kit	On Application
JW12 Foaming Lance w/1L Tank	JWA221-LS12	Remote Stop/Start	00030-B
JW Bypass Pro Foam	PROFOAM		
Turbo Head w/Lance (350BAR)	JWA159		
21" Hammerhead - Stainless Steel	JWA-FSC21-5		
30" Hammerhead - Stainless Steel	JWA-FSC30		

The manufacturer reserves the right to modify design features and technical facts without notice, due to our principals of continuous improvement.

\*Coverage against defects in material and workmanship (refer to Jetwave's and component partners T&Cs).

V2.2 08/21