

# EXECUTIVE™ G2 345



**5075**  
PSI

**23**  
L/PM

**HONDA GX690**  
PETROL  
ENGINE TYPE  
POWERED by HONDA.

**GEARBOX**  
1450RPM  
DRIVE

**HOT**  
WATER  
OUTPUT

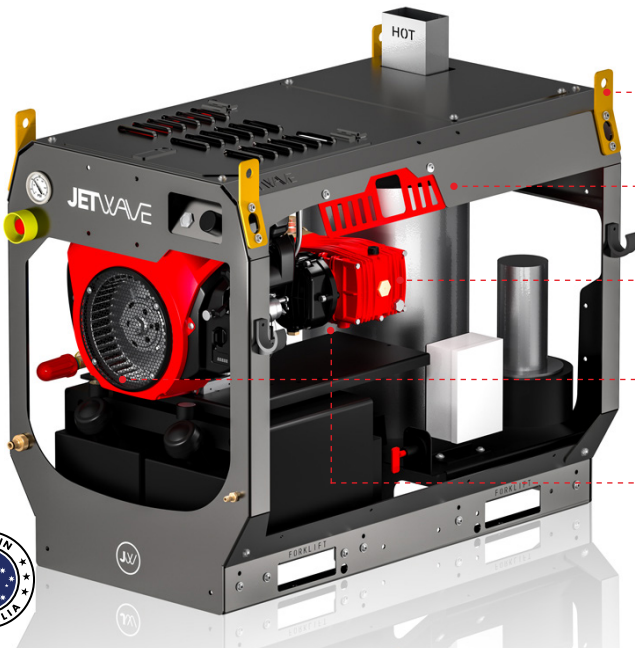

## HERO INNOVATIONS

- ETL™**  
Engineered Top Lifting Lugs
- PEXO™**  
Stainless Steel Exoskeleton
- JWPP™**  
Jetwave Italian Premium Pump
- CC™**  
Centralised Control
- AVPS™**  
Anti Vibration Protection System

## APPLICATIONS

- Tradesmen
- Commercial Cleaners
- Shipping & Logistics
- Hire & Rental

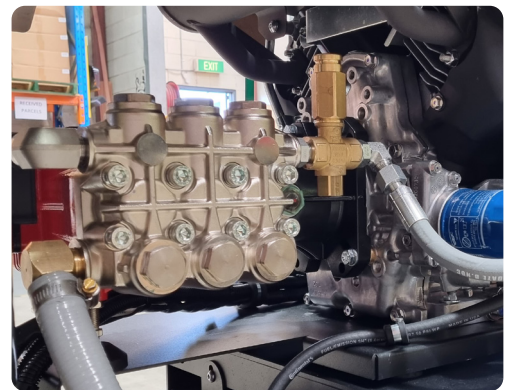

## STANDOUT FEATURES

- JW® Enhanced Italian triplex plunger pump running at 1450RPM delivers more performance and longer life.
- Electric start Industrial V-Twin Honda™ GX690 Series Engine with digital engine hour meter.
- Jetwave Safety System™ (JSS) thermal and safety valve to prevent overheating in excessive bypass and over pressurisation.
- Vertical burner with GeniSys™ 12v Advanced Burner Control with smart sensors and protective features.
- Battery isolator.
- Emergency stop.

## STANDARD EQUIPMENT



Industrial spray gun & single lance.



15m Double Wire Braid Hose with M22 Couplings.

## DIMENSIONS (MM)

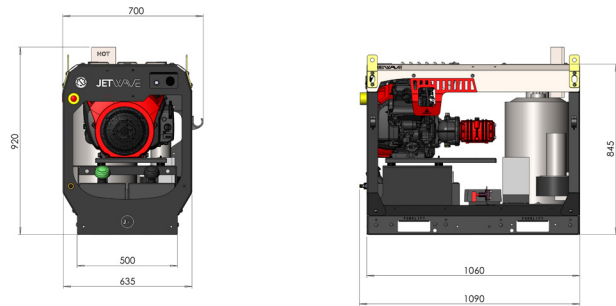

## TECHNICAL DATA

## EXECUTIVE™ G2 275 & 300

Product Code	HW5000-23PG2
Pressure / Flow Rate	5075 PSI (350 BAR) / 23 L/PM
Max Water Inlet / Outlet Temp	60°C / 90°C
Class (ASNZS: 4223)	A (8,050 Bar/Litres)
Usage Frequency	Professional - 4 Hours Daily
Nozzle Size	04
Frame Structure	CNC Modular skid galvanised steel chassis plus satin powder coat finish and <b>stainless steel cover</b>

## MOTOR FEATURES

Engine / Power	Honda™ GX690 Electric Key Start (air cooled) 23 HP / 690 CC
Fuel Type / Capacity / Protection	Unleaded / 17L / Low Oil Shutdown

## HYDRAULIC FEATURES

Pump / Head / Pistons	JW® Italian Triplex Plunger / Brass (Nickle Plated) / Ceramic
Motor Pump Coupling / Pump RPM	Gearbox Drive / 1450RPM
Unloader Valve	Independent (Zero) - Adjustable
Safety Valve	Yes
Detergent Injector	No



## THERMAL FEATURES

Burner Model	Vertical 12v High Flow Series
Fuel Supply / Capacity / Consumption	Diesel / 17L / 5.74 L/PH
Coil / Housing Material	Mild steel 3mm wall seamless (400BAR rated) / Stainless Steel

## DIMENSIONS & WEIGHT

Machine Dimensions / Weight	Skid: 1090mm(L) x 700mm(W) x 920mm(H) / 295KG
-----------------------------	---

## WARRANTY(S)

Unit / Pump Warranty*	 2 Years
Engine Warranty*	 3 Years

## OPTIONAL ACCESSORIES

## OPTIONAL UPGRADES

30m Hose Reel (Hose Reel Bracket Required)	1060CMPL	Honda iGX700 Engine Upgrade	ADD:FI
60m Hose Reel (Hose Reel Bracket Required)	1067CMPL	4 Wheel Trolley Kit	JWA407A
Hose Reel Bracket	9003OHMP-G2-R1	On-board Water Bypass Cooling Tank	90008-12ROTCMPL
Additional High Pressure Hose	52001	Low Level Water Cut Out	JWA220
JW Bypass Pro Foam	PROFOAM	Hose Reel Roller Guide HGS™	1067-GUIDEASSY (1067 Only)
Turbo Head w/Lance (350BAR)	JWA159		
21" Hammerhead - ABS Plastic	JWA-FSC21		
21" Hammerhead - Stainless Steel	JWA-FSC21-5		

The manufacturer reserves the right to modify design features and technical facts without notice, due to our principals of continuous improvement.

\*Coverage against defects in material and workmanship (refer to Jetwave's and component partners T&Cs).

V2.2 08/21