

ITEM	PART NUMBER	TITLE	QTY
1	003-3004	SPRING KEEPER	1
2	110-3030	11 NOTCH DISC ASSEMBLY	1
3	110-3031	15 NOTCH DISC ASSEMBLY	1
4	110-3051	CLAY OPENER	1
5	124-4320	COULTER WASHER	1
6	130-4025	U-Bolt 5/8"	2
7	132-3001	SPRING COULTER	1
8	134-0090	NUT HEX 5/8 UNC ZINC	4
9	134-1025	NUT NYLOCK 3/4" UNC ZINC	1
10	135-0070	WASHER SPRING 5/8"	4
11	135-0080	FLAT WASHER 5/8	4
12	140-0004	PIN CLEVIS 1" 115mm CAT2 TOP	1
13	140-0039	LYNCH PIN 11mm 32mm	3
14	140-4039	PIN CLEVIS 1" 76mm CAT2	1
15	300-3000	SWIVEL HEAD	1
*16	300-4010	SWIVEL COULTER MOUNT	1
17	300-4024	SPRING CONROD	1
18	302-3003	PASTURE DISC SEEDTUBE	1
19	302-3004	PASTURE ARM	1

*FOR OPTIONAL OFFSET MOUNT USE THE FOLLOWING:

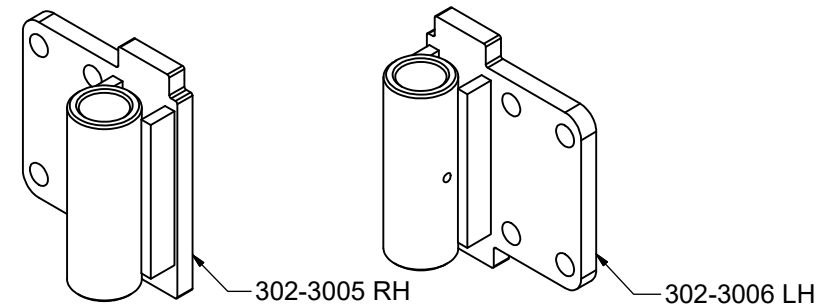

AGROWPLOW

COPYRIGHT RESERVED
THIS DRAWING IS THE PROPERTY OF AGROWPLOW PTY LTD AND IS SUBJECT TO RETURN UPON DEMAND. IT IS SUBMITTED FOR USE ONLY IN CONNECTION WITH PROPOSALS OR CONTRACTS OF THIS ORGANISATION UPON THE EXPRESS CONDITION THAT IT IS NOT TO BE USED DIRECTLY OR INDIRECTLY IN ANY WAY DETRIMENTAL TO THE INTERESTS OF AGROWPLOW PTY LTD.

TITLE:
400 PASTURE DISC ASSY

PART NUMBER:
405-1000

SHEET 1 OF 2 PAGE

DISC ASSEMBLY
 PART NUMBER 11NOTCH - 110-3030
 15 NOTCH - 110-3031

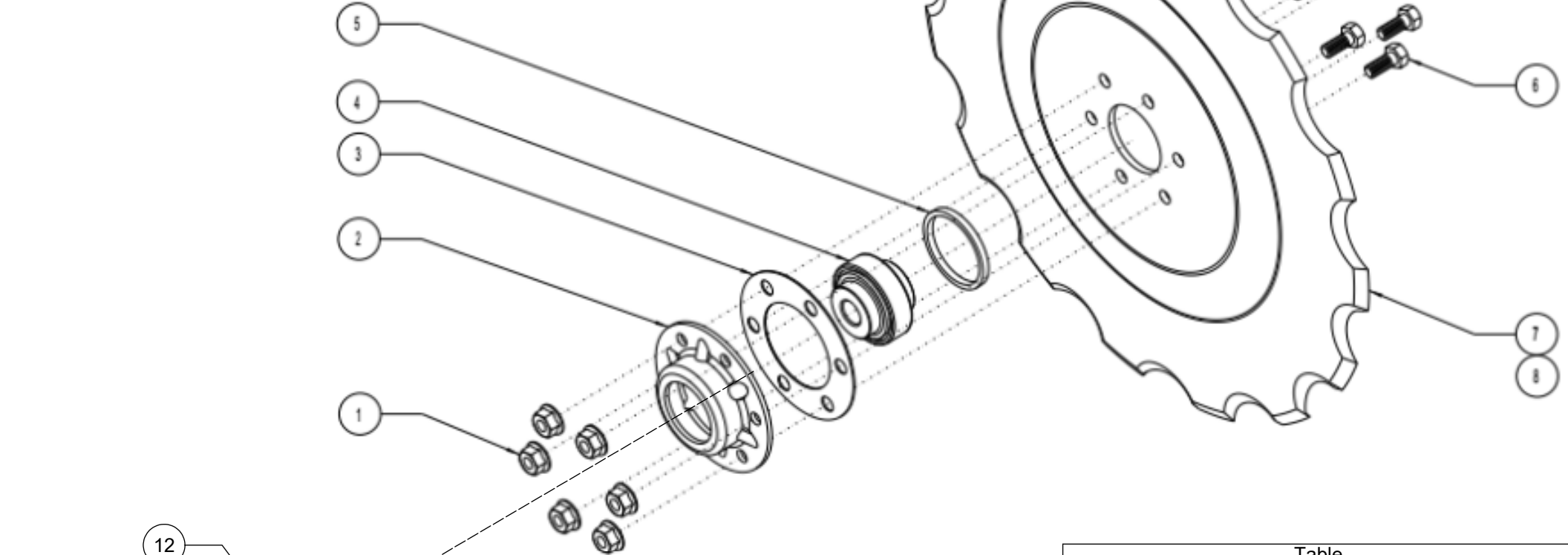

BEARING COVER TO
 GO ON AFTER DISC
 IS ASSEMBLED
 (ITEM 9, 110-4003)

Table

ITEM	PART No.	DESCRIPTION	QTY.
1	134-1015	NYLOC NUT 5/16"	6
2	110-4112	BEARING HOUSING	1
3	110-4002	GASKET (OBSOLETE)	1
4	138-3025	BEARING	1
5	110-4004	RETAINING RING	1
6	133-1021	BOLT 5/16" x 3/4"	6
7	110-4011	DISC 11 NOTCH	1
8	110-4015	DISC 15 NOTCH	1
9	110-4003	PLATED COVER AP-299041	1
10	110-4005	LH BOLT	1
11	113-2060	RH BOLT	1
12	135-1036	5/8 FLAT WASHER	1

AGROWFLOW

COPYRIGHT RESERVED
 THIS DRAWING IS THE PROPERTY OF AGROWFLOW PTY LTD AND IS SUBJECT TO RETURN UPON DEMAND. IT IS SUBMITTED FOR USE ONLY IN CONNECTION WITH PROPOSALS OR CONTRACTS OF THIS ORGANISATION UPON THE EXPRESS CONDITION THAT IT IS NOT TO BE USED DIRECTLY OR INDIRECTLY IN ANY WAY DETRIMENTAL TO THE INTERESTS OF AGROWFLOW PTY LTD.

TITLE:
**400 PASTURE DISC
 ASSY**

PART NUMBER:
405-1000

SHEET 2 OF 2

PAGE