



FREESKY
go anywhere

USER MANUAL

20" ROCKY ELECTRIC BIKE





YANSHAN Technology Co., LTD

Contact us if you experience issues relating to riding
Maintenance and safety, or errors/faults with your FREESKY e-bike

 freeskycycle.com

 support@freeskycycle.com

 611 Reyes Dr. City of Industry Walnut CA 91789

 (909)892-8680 (available from 5 P.M. to 8 P.M.PST)

 Freesky-ebike

 @FREESKYEBike

 Freesky club:FREESKYEBike/groups



Rocky

Mountain e-Bike



Words to Users

Thank you for choosing Freesky! In order to make it easier for you to experience the product and be safe at riding, detailed instruction is provided, from which you can find the product's instruction, usage and other information. Before using this product, please read the manual carefully so that you can correctly use it.

Contents

User Precautions	01
Package List	02
Product Overview	03
Assembly	04
Start-Up Procedure	15
Display and Setting	18
Troubleshooting	27
Specifications	28
FAQS	29
Limited Warranty	30



Product Safety Notice



Don't Ride Until You Read This:



Always wear a helmet when riding your electric bike.



Keep the two keys properly. If the unique keys are lost, you will not be able to turn on the bike or replace the battery. If necessary, you should get more spare keys. (We don't have a backup key)



Make sure your electric bike has a full battery before taking it out to ride.



Always respect pedestrians.



Do not ride under wet conditions. The electric bike may slide from under your feet causing injury. Wet conditions may damage the electronics and void the warranty.



Always be aware of local road laws, and follow them.



Package List

Carefully check package contents, if anything is missing or damaged, please contact Freesky customer service for support: support@freeskycycle.com

Unpack the bike. Open the bike box and remove the small box inside. With the help of another person capable of safely lifting a heavy object, remove the bike from the bike box. Carefully remove the packaging material protecting the bike frame and components. Please recycle packaging materials especially card board and foam whenever possible. Open the small box and carefully set out all contents.

 <p>1x Electric Bike</p>	 <p>1x Charger</p>	 <p>2x Pedals</p>
 <p>2x Wrench 3x Allen Key Wrench</p>	 <p>2x Keys</p>	 <p>1x User Manual</p>
 <p>1x Saddle</p>	 <p>1x Skewer</p>	 <p>1x Fender</p>



Product Overview





Handlebar Assembly

1



1.Remove the 4 screw.

2



2.Install the handlebar.

3



3.Fix and tighten the handlebar in place.

4



4. Make sure the shifter is on the right and the throttle on the left.



Front Wheel Assembly

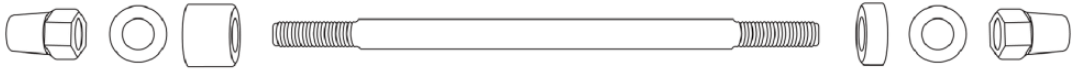

Figure 1

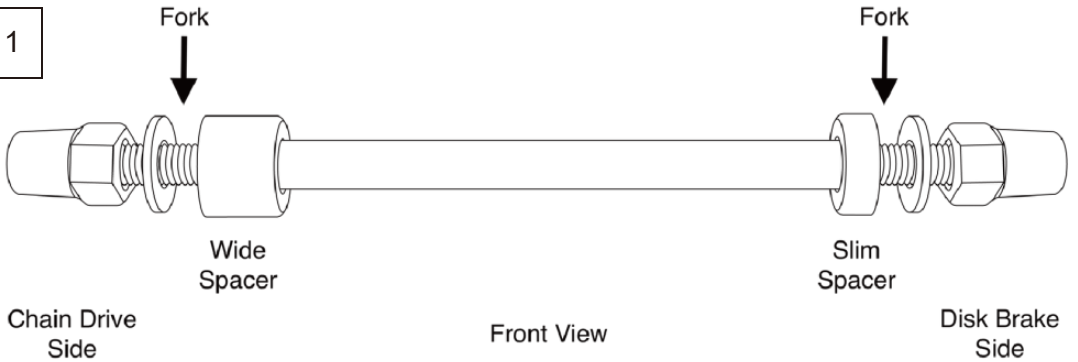
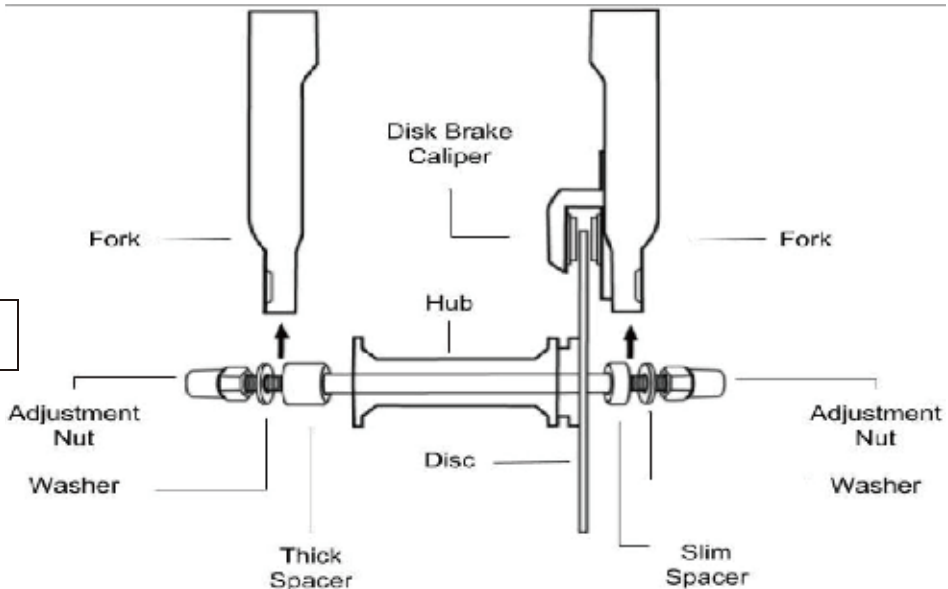

Figure 2



1. Insert the axle into the wheel hub as shown. Add the Slim Spacer on the **LEFT** side (Brake Disk) and the Wide Spacer on the **RIGHT** side.
2. Insert the front wheel with the spacers in between the front fork on the bike. Be sure to align the disk between the brake caliper as shown in Figure 2.
3. Now on the outside add the washer and nut on each side and hand turn until snug.
4. Using your wrench, tighten each side alternatively until snug (you might need to secure the opposite nut slightly so the whole axle doesn't turn)
5. Now tighten each nut putting your weight into the wrench. Your front wheel is now installed.
6. The Adjustment Nut needs to be very tight, be sure to retighten after your first couple rides.



Front Light and Fender Assembly

1



1.Remove the headlight mounting hardware from the fork arch.

2



2.Pass the bolt through the headlight mount, fender mounting point and the fork arch mounting point, then tighten the nut.

3



3.Connect the headlight cable.

4



4.Remove the screws on both sides of the front fork arms and then tighten the iron bar.



Saddle Assembly

For better pedaling, safety and overall riding comfort, positioning the seat at the right height is important. The rider's leg length is used to determine the seat's position. When you pedal, your hips should remain level and your legs should be almost fully extended at the bottom of the pedal stroke, but not over-extended. To determine the right seat height, sit on the e-Bike with one pedal at its lowest point and place the ball of your foot on the pedal. Your leg should be almost fully extended(not locked out) with a slight bend at the knee.

1

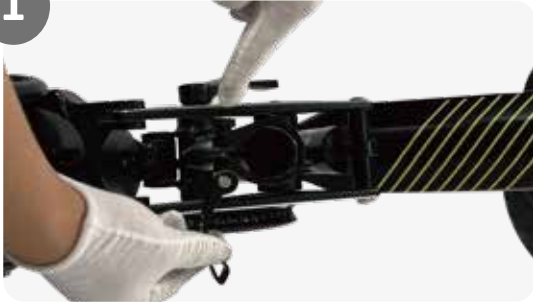

1. Open the quick release lever by swinging the lever open and outward fully.

2



2. Insert the seat post into the seat tube.

3



3. Tighten the securing nut.

4



4. Close the quick release lever using your palm or finger.



Seatpost Adjustment

(1) NOTICE: Ensure the seat post and seat are properly adjusted before riding. DO NOT raise the seat post beyond the minimum insertion marking etched into the seat tube (as shown on the right). If the seat post projects from the frame beyond these markings, the seat post or frame may break, which could cause a rider to lose control and fall. Ensure the minimum insertion markings on the seat post inside the seat tube of the frame.



(2) Before using the bike, always check to ensure all latches, levers, and quick releases are properly secured and undamaged. Check that they are correctly secured before every ride and after every time the bike is left unsupervised, even for a short time. Otherwise, the handlebar stem and/or seat post may come loose and can result in loss of control, damage to the bike, property, serious injury, and/or death.





Front Fork Adjustment

The suspension fork can move up and down up to 80mm to cushion bumps in the riding surface, which can make riding on a rough road or trail smoother and more comfortable.

Depending on a rider's preference, the suspension fork can be locked out as a rigid fork, which will typically yield higher efficiency while pedaling.

The lockout lever(1), located on top of the right side of the suspension fork, can be turned counterclockwise until it stops to completely lockout the suspension fork's travel. To unlock the lockout lever, turn the knob clockwise until it stops. When the lockout lever is unlocked, resistance can be adjusted by turning.

The preload adjustment knob(2), located on the top of the left side of the suspension fork. To soften the ride, subtract resistance by turning the preload adjustment knob counterclockwise, in the direction of the small "-" on the knob. To make the suspension suffer when going over bumps, add resistance by turning the preload adjustment knob clockwise, in the direction of the small "+" on the knob.





Pedals Assembly

1. **Warning:** Incorrect installation will cause damage. Please read the instructions and watch our videos if needed.
2. Identify the Left and Right markings on the pedals. They can only be installed in their respective side.
 - a. L is for the Left Pedal and it goes on the Left Crank Arm.
 - b. R is for the Right pedal and it goes on the Right Crank Arm (Chain Side)

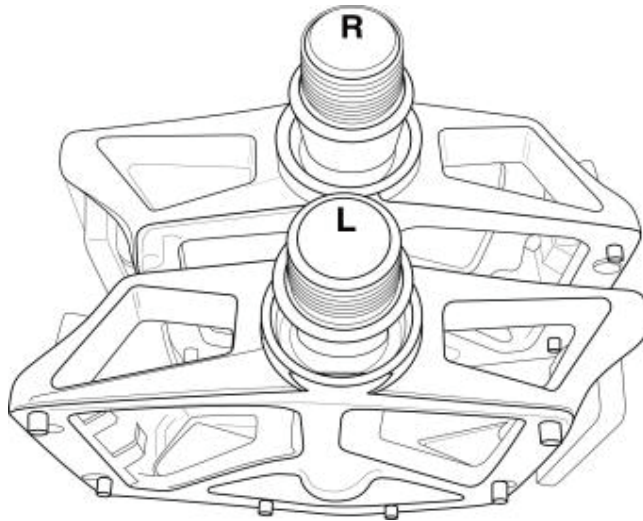

3. Sitting on your bike the pedals go on the Left and Right side respectively.
4. Keep the pedal Horizontal while hand screwing to get the thread started. Then Use your 15mm wrench to tighten them.
5. Both pedals tighten towards the front of the bike. The left pedal is reverse threaded to allow this.
6. The pedals need to be very tight, be sure to retighten after your first couple rides.

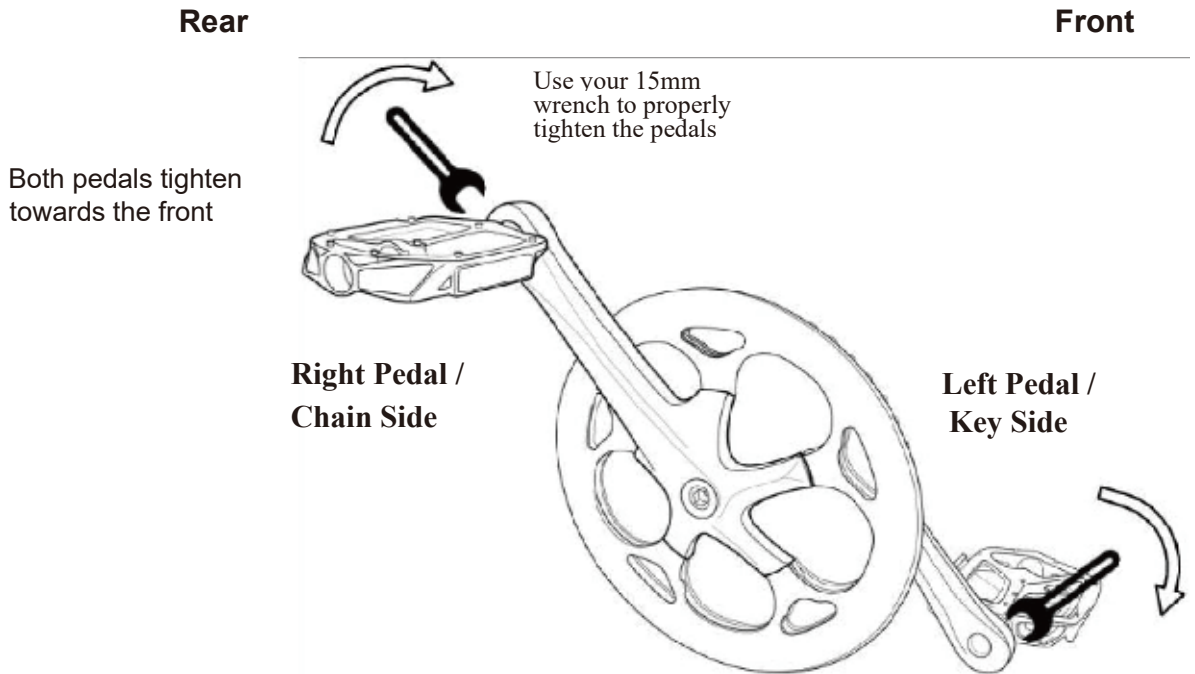



Remove the battery

For your convenience, the battery can be removed.

1



1. Insert the key and turn counter-clockwise.

2



2. Press the release button and hold the battery.

3



3. Remove the battery.

4



4. Press the power button to see the remaining battery power.



Charge Your E-Bike

Before using the electric bike, you must fully charge the battery.

1



1.Remove the rubber cover on the charging port and charge the battery directly.

2



2.Charge the battery off the bike.

3



3.Plug the charger into a power outlet, charging should be initiated and will be indicated by the LED charge status lights on the charger. When the light turns red, it means the battery was now charging. Please make sure to connect the battery first and then connect the wall outlet.

4





4.Once the battery is fully charged, the charging indicator light will turn green. Unplug the charger from the wall outlet first and then remove the charger output end from the battery charging port.



Start-Up Procedure

After the bike has been properly assembled according to the assembly video, please check all components are secured correctly, and read this ensure manual carefully, turn on the bike and select a pedal assist level. A certified and reputable mechanic to checked the assembly will be a good choice. Following are the steps:

1. Test the battery lock security. Ensure the key in lock position by turning the key clockwise.
2. Ensure proper handlebar and seat adjustment. A proper seat position will offer you safer and comfortable riding experience. Before riding, adjust the seat height until the rider can put one or both feet flat on the ground without too much difficulty to operate the bike. Ensure the handlebar faceplate bolts and seatpost quick release are fully and properly secured.
3. Turn the bike on. Hold down the center power (M or i) button in the control panel for approximately 3 seconds until power is delivered to the LCD Display.
4. Turn on the headlight and taillight if needed or desired. Once the LCD Display is on, press  button.
5. Select the desired level of pedal assistance (PAS) from level 1 to level 5 using the  and  on the display remote. Level 1 corresponds to the lowest level of pedal assistance, and level 5 corresponds to the highest level of pedal assistance. Level 0 indicates pedal assistance is inactive. Start in PAS level 0 or 1 and adjust from there.
6. Start your ride. With the proper safety gear and rider knowledge, you may now operate your bike on a flat surface, in a low gear (1 or 2). Most riders should be able to begin pedaling the bike with pedal assist level 1 or 2. You may also use the throttle to accelerate and maintain your desired speed.
7. Throttle. Please press the throttle gently with your figure. If the rider press and hold the throttle to the end position in a quick way, the bike will go with the maximum speed in seconds. Do not use the throttle unless you are on the bike.



Do not use the throttle while dismounted. Avoid accidental application of the throttle while dismounted. Anytime you are moving the bike while dismounted, ensure the bike is powered off to prevent accidental application of the throttle.



Display Details

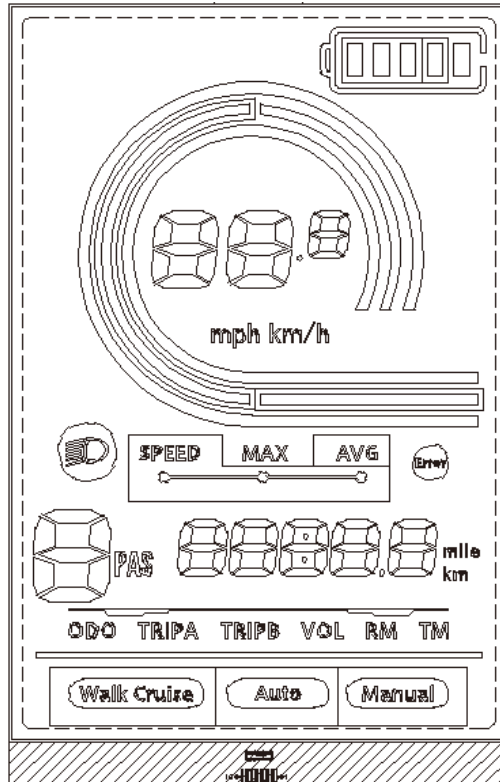

1. Light



2. Battery Level



3.Multi-Functions Display

TRIP: Single Mileage

ODO: Total Mileage

TIME: Single Running Time

VOL: Current Voltage

CUR: Operating Current

DST: Unspecified

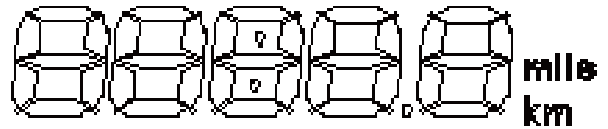

4.Vehicle Power Gear

Gear 0-9 adjustable ;

Normally 3 / 5 / 9-gear mode available.



5.Speed Display

MAX: Maximum Speed

AVG: Average Speed

MPH or KM/H: Measuring Unit

The panel will calculate the actual travelling speed based on the wheel diameter and signal data (number of magnet steel is needed for Hall motors).

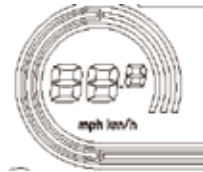

6.Vehicle Status

Real-Time Cruise



Controller Failure



Powered Ride



Motor Failure



Low Battery



Handlebar Failure



Display Settings

Long press + & - after the bike is powered on, it will enter the parameter setting interface.

Short press **M** button, shifting from P01 to P17.

Short press + or - to change the parameters.

Long press + & - to save the change.

Each parameter could affect the bike's performance separately, please try to keep the original settings. Or please consult us if you need information.

P01: Backlight Brightness (1: darkest; 3: brightest)

P02: Mileage Unit (0: KM; 1: MILE)

P03: Voltage Class (24v , 36v , 48v)

P04: Sleep Interval

(0: never, other value means display sleep interval) Unit: minute

P05: Power Assist Grades

3 Gear Mode: 3 speed for PAS

5 Gear Mode: 5 speed for PAS

9 Gear Mode: 9 speed for PAS

The more grades, the acceleration will be more linear.

P06: Wheel Diameter Unit: inch Range: 4.9-30.4

P07: Magnet Steel Number (for Speed Test) Range: 0-255

P08: Speed Limit

Range: 0-100km/h, parameter 100 indicates no speed limit.

1. Non-communications status (panel-controlled)

When the current speed exceeds the speed limit, the PWM output will be shut down; when the current speed falls to lower than the speed limit, the PWM output will be activated and the driving speed will be set as the current speed ± 1 km/h (only applies to assist power speed, not applicable to the handlebar speed).

2. Communications status (controller-controlled)

The driving speed will be kept constant as the limited value.

Error Value: ± 1 km/h (applicable to both the assist power/handlebar speed)

Note: The above-mentioned values are measured by metric unit (kilometers).

When the measuring unit is switched to imperial unit (mile), the speed value displayed on the panel will be automatically switched to corresponding imperial unit, however the speed limit value in the imperial unit interface won't change accordingly.

P09: Direct Start / Kick-to-Start Setting 0: Direct Start 1: Kick-to-Start

P10: Drive Mode Setting

0: Power Assist – The specific gear of the assist drive decides the assist power value. In this status the handlebar does not work.

1: Electric Drive – The vehicle is driven by the handlebar. In this status the power gear does not work.

2: Power Assist + Electric Drive – Electric drive does not work in zero-start status.

P11: Power Assist Sensitivity Range: 1-24

P12: Power Assist Intensity Range: 0-5

P13: Power Magnet Steel Number : 5 / 8 / 12pcs

P14: Current Limit Value: Range: 1-20A

P15: Low voltage limit: (change automatically according to P03)

P16: Cruise control: not applicable.

P17: ODO Zero-Out

Long press + for 5 seconds and ODO value will be erased.

Daily Care and Maintenance

Cleaning and Storage

If you see stains on the bike body, wipe them off with a damp cloth. If the stains won't scrub off, put on some toothpaste, and brush them with a tooth brush, then wipe them off with a damp cloth.

Notes: do not clean the bike with alcohol, gasoline, kerosene or other corrosive and volatile chemical solvents to prevent dire damage. Do not wash the bike with a high-pressure water spray. During cleaning, make sure that the bike is turned off, the charging cable is unplugged, and the rubber flap is closed as water leakage may result in electric shock or other major problems. When the bike is not in use, keep it indoors where it is dry and cool. Do not put it outdoors for along time. Excessive sunlight, overheating and over cooling accelerate the battery pack's life span.

Battery Maintenance

1. Use original battery packs, use of other models or brands may bring about safety issues;
2. Do not touch the contact. Do not dismantle or puncture the casing. Keep the contacts away from metal objects to prevent short circuit which may result in battery damage or even injuries and deaths;
3. Use original power adapter to avoid potential damage or fire;
4. Mishandling of used batteries may do tremendous harm to the environment. To protect natural environment, please follow local regulations to properly dispose used batteries.
5. After every use, fully charge the battery to prolong its life span.

Storage and Disposal

1. Please try to store the bike in a cool and dry place between 50 °F – 77 °F (10 °C – 25 °C). In extremely humid environments the interior of the bike may suffer condensation or even water accumulation, which may damage the battery rapidly. Devices are not intended for use at elevations greater than 2000m above sea level prolonged exposure to UV rays, rain and the elements may damage the enclosure materials, store indoors when not in use.
2. In daily use, try to avoid recharging the bike after completely exhausting the battery. If the battery is low, charge it as soon as possible.
3. Please charge the bike every other month to preserve the battery.

Recommended Service Intervals

Regular inspection and maintenance are key to ensure bikes from Freesky function as intended, and to reduce wear and tear on their systems. Recommended service intervals are meant to be used as guidelines. Real world wear and tear, and the need for service, will vary with condition of use. We generally recommend inspections, service, and necessary replacements be performed at the time or mileage interval that comes first in the following table.

Interval	Inspect	Service	Replace
Weekly, 100-200 miles (160-321 km)	<ul style="list-style-type: none"> - Check drivetrain for proper alignment and function (including the chain, freewheel, chainring, and derailleur). - Check wheel trueness and for quiet wheel operation (without spoke noise). - Check condition of frame for any damage. 	<ul style="list-style-type: none"> - Clean frame by wiping frame down with damp cloth. - Use barrel adjuster(s) to tension derailleur/brake cables if needed. 	<ul style="list-style-type: none"> - Replace any components confirmed by Freesky, Product Support or a certified reputable bike mechanic to be damaged beyond repair or broken.
Monthly, 250-750 miles (402-1207 km)	<ul style="list-style-type: none"> - Check bike is shifting properly, proper derailleur cable tension. - Check chain stretch. - Check spoke tension. - Check accessory mounting (rack mounting bolts, and alignment). 	<ul style="list-style-type: none"> - Clean and lubricate drivetrain. - Check crankset and pedal torque. - Clean brake and shift cables. - True and tension wheels if any loose spokes are discovered. - Balance the battery. 	<ul style="list-style-type: none"> - Replace brake and shift cables if necessary. - Replace brake pads if necessary.
Every 6 Months, 750-1250miles (1207-2011 km)	<ul style="list-style-type: none"> - Inspect drivetrain (chain, chainring, freewheel, and derailleur). - Inspect all cables and housings. 	<ul style="list-style-type: none"> - Standard tune-up by certified, reputable bike mechanic is recommended. - Grease bottom bracket. 	<ul style="list-style-type: none"> - Replace brake pads. - Replace tires if necessary. - Replace cables and housings if necessary.

Pre-Ride Safety Checklist

Notice: Before every ride, and after every 25-45 miles(40-72 km), we advise you following the pre-ride safety checklist.

Safety Check	
1.Brakes	Ensure front and rear brakes work properly. Check brake pads for wear and ensure they are not overworn. Ensure brake pads are correctly positioned in relation to the rims. Ensure brake levers are lubricated and tightly secured to the handlebar. Test that the brake levers are firm and that the brake is functioning properly.
2.Wheels and Tires	Ensure tires are inflated within the recommended limits posted on the tire sidewalls and hold air. Ensure tires have good tread, have no bulges or excessive wear, and are free from any other damage. Ensure rims run true and have no obvious wobbles, dents, or kinks. Ensure all wheel spokes are tight and not broken. Check axle nuts and front wheel quick release to ensure they are tight. Ensure the locking lever on the quick release skewer is correctly tensioned, fully closed, and secured.
3.Steering	Ensure the handlebar and stem are correctly adjusted, tightened, and allow proper steering. Perform a handlebar twist test to ensure the stem clamp bolt security. Ensure the handlebar is set correctly in relation to the fork and the direction of travel
4.Chain	Ensure the chain is clean, oiled, and runs smoothly. Extra care is required in wet, salty/otherwise corrosive, or dusty conditions.
5.Bearings	Ensure all bearings are lubricated, run freely, and display no excess movement, grinding, or rattling. Check headset, wheel bearings, pedal bearings, and bottom bracket bearings.
6.Cranks and Pedals	Ensure pedals are securely tightened to the cranks. Ensure the cranks are securely tightened and are not bent.
7.Derailleur and Mechanical Cables	Check that the derailleur is adjusted and functioning properly. Ensure shifter and brake levers are attached to the handlebar securely. Ensure all shifter and brake cables are properly lubricated.

Safety Check	
8.Frame, Fork, and Seat	<p>Check that the frame and fork are not bent or broken.</p> <p>If either frame or fork are bent or broken, they should be replaced.</p> <p>Check that the seat is adjusted properly, and seatpost quick release lever is securely tightened.</p>
9.Motor Drive Assembly and Throttle	<p>Ensure hub motor is spinning smoothly and motor bearings are in good working order.</p> <p>Ensure all power cables running to hub motor are secured and undamaged.</p> <p>Make sure the hub motor axle bolts are secured and the torque arm, torque arm bolt, and torque washers are in place.</p>
10.Battery	<p>Ensure battery is charged before use.</p> <p>Ensure there is no damage to battery.</p> <p>Lock battery to frame and ensure that it is secured.</p> <p>Charge and store bike and battery in a dry location, between 50 °F – 77 °F (10 °C – 25 °C).</p> <p>Let bike dry completely before using again.</p>
11.Electrical Cables	<p>Look over connectors to make sure they are fully seated and free from debris or moisture.</p> <p>Check cables and cable housing for obvious signs of damage.</p> <p>Ensure front light is functioning, adjusted properly, and unobstructed.</p>
12.Accessories	<p>Ensure all reflectors are properly fitted and not obscured.</p> <p>Ensure all other fittings on bike are properly secured and functioning.</p> <p>Inspect helmet and other safety gear for signs of damage.</p> <p>Ensure rider is wearing a helmet and other required riding safety gear.</p> <p>Ensure mounting hardware is properly secured if fitted with a front rack, rear rack, basket, etc.</p> <p>Ensure the taillight and taillight power wire are properly secured if fitted with rear rack.</p> <p>Ensure the fender mounting hardware is properly secured if fitted with fenders.</p> <p>Ensure there are no cracks or holes in fenders.</p> <p>If installed, ensure the optional rear wheel lock is secured in the unlocked position and the key is removed before every ride.</p>



Your cables, spokes, and chain will stretch after an initial break-in period of 50-100 mi (80-160 km), and bolted connections can loosen. Always have a certified, reputable bike mechanic perform a tune-up on your bike after your initial break-in period of 50-100 mi (80-160 km) (depending on riding conditions such as total weight, riding characteristics, and terrain). Regular inspections and tune-ups are particularly important for ensuring that your bike remains safe and fun to ride.

Tire Inflation and Replacement

The Rocky employs 20"×4" rubber tires with inner tubes. The tires are designed for durability and safety for regular cycling activities and need to be checked before each use for proper inflation and condition. Proper inflation, care, and timely replacement will help ensure that your bike's operational characteristics will be maintained, and unsafe conditions avoided.

Freesky recommends 24-30 PSI for the stock tires on the Freesky. Always stay within the manufacturer's recommended air pressure range as listed on the tire sidewall.



It is critically important to check the tire situation and make sure no tire burges or tire pop off. Inflate the air into the tube slowly and carefully, check whether the tire and tube are in place on the rim, squeeze the tire properly to make the tire always in the center of the wheel. Inflate the air pressure around 5 psi and check the tire's evenness with the rim and then another 5 psi until the pressure comes to 85% of the rated maximum pressure on the tire side wall.

Do not underinflate or overinflate your tires. Low pressure may result in loss of control, and overinflated tires may burst. Failure to always maintain the air pressure rating indicated on pneumatic tires may result in tire and/or wheel failure.



Inflate your tires from a regulated air source with an available pressure gauge. Inflating your tires from an unregulated air source could overinflate them, resulting in a burst tire.

Even tires equipped with built-in, flat-preventative tire liners, like those that come with bikes from Freesky, can and do get flats from punctures, pinches, impact, and other causes. When tire wear becomes evident or a flat tire is discovered, tires and/or tubes must be replaced before operating the bike or injury to operators and/or damage to your bike from Freesky could occur.



When changing a tire or tube, ensure that all air pressure has been removed from the inner tube prior to removing the tire from the rim. Failure to remove all air pressure from the inner tube could result in serious injury.



Using aftermarket tires or inner tubes, not provided by Freesky may void your warranty, create an unsafe riding condition, or damage to your bike. If required by law, ensure replacement aftermarket tires have sufficient reflective sidewall striping.

For more information on tire or tube replacement procedures, or questions about tire inflation, visit freeskycycle.com/pages/help-center or contact Freesky Product Support.

Email: support@freeskycycle.com

Troubleshooting

	Symptoms	Possible Causes	Most Common Solutions
1	The bike does not work	<ol style="list-style-type: none"> 1. Insufficient battery power 2. Faulty connections 3. Battery not fully seated in tray 4. Improper turn on sequence 5. Brakes are applied 6. Blown discharge fuse 	<ol style="list-style-type: none"> 1. Charge the battery 2. Clean and repair connectors 3. Install battery correctly 4. Turn on bike with proper sequence 5. Disengage brakes 6. Replace discharge fuse
2	Irregular acceleration and/or reduced top speed	<ol style="list-style-type: none"> 1. Insufficient battery power 2. Loose or damaged throttle 3. Misaligned or damaged magnet ring 	<ol style="list-style-type: none"> 1. Charge or replace battery 2. Replace throttle 3. Align or replace magnet ring
3	The motor does not respond when the bike is powered on	<ol style="list-style-type: none"> 1. Loose wiring 2. Loose or damaged throttle 3. Loose or damaged motor plug wire 4. Damaged motor 	<ol style="list-style-type: none"> 1. Repair and or reconnect 2. Tighten or replace 3. Secure or replace 4. Repair or replace
4	Reduced range	<ol style="list-style-type: none"> 1. Low tire pressure 2. Low or faulty battery 3. Driving with too many hills, headwind, braking, and/or excessive load 4. Battery discharged for long period of time without regular charges, aged, damaged, or unbalanced 5. Brakes rubbing 	<ol style="list-style-type: none"> 1. Adjust tire pressure 2. Check connections or charge battery 3. Assist with pedals or adjust route 4. Balance the battery; contact Tech Support if range decline persists 5. Adjust the brakes
5	The battery will not charge	<ol style="list-style-type: none"> 1. Charger not well connected 2. Charger damaged 3. Battery damaged 4. Wiring damaged 5. Blown charge fuse 	<ol style="list-style-type: none"> 1. Adjust the connections 2. Replace 3. Replace 4. Repair or replace 5. Replace charge fuse
6	Wheel or motor makes strange noises	<ol style="list-style-type: none"> 1. Loose or damaged wheel spokes or rim 2. Loose or damaged motor wiring 	<ol style="list-style-type: none"> 1. Tighten, repair, or replace 2. Reconnect or replace motor.

Specifications

ITEM	SPECIFICATIONS
Model	Rocky
Product Dimensions	175×63×122(cm)
Package Dimensions	146×30×76(cm)
Max Load	300 lbs(135kg)
Package Weight	88 lbs(40kg)
E Bike Weight	75 lbs(34kg)
Max Speed	32 mph(50km/h)
Battery/Charger	Input 100-240V 50/60HZ AC Plug; Output 54.6V 2A
Pedal-Assist Mode	40-60 miles
Pure Electric Mode	22-30 miles
Max Angle of Climb	30 degrees
Charging Time	4-8 hours
Tire Pressure	24-30 PSI
Recommended Rider Heights	5'1"-6'4"
Charging Port	Output Voltage 54.6V 2A
Frame Material	Artificial Mechanics 6061 Aluminum Alloy Frame
IP Level	Ip65

FAQS

Q: What if the e-bike arrived missing accessory or broken part?

A: Please take a photo and send them to Freesky Support Team by email: support@freeskycycle.com and our support team will reply you soon and send correct accessory or part replacement.

Q: Will my bike arrive assembled?

A: Your bike will arrive mostly assembled. We'll also provide the tools and a comprehensive assembly video for the rest part.

Q: What can I do if something goes wrong with my e-bike during the warranty?

A: We believe that communication is the best way to solve the problem. Please contact us in time. To help you solve the problem as quickly as possible, please describe the problem in detail and provide photos/videos with your order ID.

Limited Warranty

30 DAYS SATISFACTION GUARANTEED RETURN POLICY

If you are unsatisfied with your purchase, Freesky's return policy allows you to return the product purchased on the Authorization channel within 30 days counting from the date of receipt of shipment, and request will be satisfied through the Authorization channel.

Note: Express shipping cost is non-refundable.

To be eligible for a return, your item must be in the same condition that you received it, unworn, unused, and the bike must have less than ten (10) miles on the odometer, be free of any wear and tear, dirt, dust, fragrance, or any other signs of use and must include all items that were inside the box (charger, keys, hardware, etc.).

Over 30 days: Return is not acceptable. If you come across any issues about the bike, we will help you diagnose the issue and offer the best solution.

We will deduct the shipping fee or restocking \$150/pc when we are making a refund for non-defective products-nolonger needed Products.

For the return request, Freesky is not responsible for lost packages due to the carrier, or products received that can not be verified. Received products that have damage determined to have been caused by the end-user maybe subject to denial of the return request.

TO QUALIFY FOR A REFUND , ALL THE FOLLOWING CONDITIONS MUST BE MET:

- 1.A Return Merchandise Authorization(RMA) must be requested from Freesky within 30 days from the date of receipt of shipment. To request an RMA, contact Freesky Service Team at support@freeskycycle.com
- 2.The cost of return shipping will be paid by the customer.
- 3.For warranty service, please keep your receipt and/or invoice to validate proof of purchase.
- 4.Returned product must be in good physical condition(not physically broken or damaged).
- 5.All accessories originally included with your purchase must be included with your return.
- 6.If you return a product to Freesky,(a) without an RMA from Freesky,(b) without all parts included in the original package, Freesky retains the right to refuse delivery of such return.

LIMITED PRODUCT WARRANTY

Freesky warrants the original purchaser that your Freesky product shall be free from defects in materials and workmanship under normal use for a period aforementioned. Freesky does not warrant the operation of the product will be uninterrupted or error-free.

- Only the original owner of an e-bike purchased from Freesky online or physical storefront is covered by this Limited Warranty. The Warranty Period begins upon your receipt of the e-bike and shall end immediately upon the earlier of the end of the Warranty Period or any sale or transfer of the e-bike to another person, and under no circumstances shall the Limited Warranty apply to any subsequent owner or other transferee of the e-bike.

- The Limited Warranty is expressly limited to the replacement of a defective lithium ion battery (the “Battery”), frame, forks, stem, handlebar, headset, seat post, saddle, brakes, lights, bottom bracket, crank set, pedals, rims, wheel hub, freewheel, cassette, derailleur, shifter, motor, throttle, controller, wiring harness, LCD display, kickstand, reflectors and hardware (each a “Covered Component”).

- The Covered Components are warranted to be free of defects in materials and/or workmanship during the Warranty Period.

Limited Warranty Does Not Cover:

- Normal wear and tear of any Covered Component.
- Consumables or normal wear and tear parts (including without limitation tires, tubes, brake pads, cables and housing, grips, chain and spokes).
- Any damage or defects to Covered Components resulting from failure to follow instructions in the e-bike owner’s manual, acts of God, accident, misuse, neglect, abuse, commercial use, alterations, modification, improper assembly, installation of parts or accessories not originally intended or compatible with the e-bike as sold, operator error, water damage, extreme riding, stunt riding, or improper follow-up maintenance.
- For the avoidance of doubt, Freesky will not be liable and/or responsible for any damage, failure or loss caused by any unauthorized service or use of unauthorized parts.
- The Battery is not warranted from damage resulting from power surges, use of an improper charger, improper maintenance or other such misuse, normal wear or water damage.
- Any products sold by Freesky that is not an e-bike.

DETERMINING WHETHER DAMAGE OR DEFECT TO AN EBIKE OR COVERED COMPONENT IS PROTECTED BY THIS LIMITED WARRANTY SHALL BE IN THE SOLE DISCRETION OF RPB.



FREESKY
go anywhere