

LEXUS RC300 / RC350 RWD / AWD 15-18

GRIP CATBACK EXHAUST SYSTEM

INSTALLATION GUIDE



Congratulations on purchasing the ARK Performance premium exhaust system! Please read and understand these instructions before beginning work on the installation of your new ARK Performance exhaust system. If you do not fully understand any of the instructions, please give us a call at 909-947-1ARK (1275) or email us at support@ARKPerformanceusa.com



Before beginning installation, please verify that you have received all the pieces of your exhaust system. All ARK Performance exhaust systems will come with the exhaust system and hardware (gaskets/clamps and nuts and bolts). If you are missing any pieces, please contact ARK Performance.

We highly recommend that this exhaust system be installed by **someone qualified for this work or by a certified mechanic** with access to the appropriate hand or power tools. It is also recommended that a lift or hoist be used during the installation. By installing this ARK Performance exhaust system, you indicate that you have read this information guide and you agree with the terms and conditions stated.

It is your responsibility to **follow the instructions** provided for this ARK Performance exhaust system and exercise all necessary safety precautions. ARK Performance assumes no responsibility for damages occurring from improper installation, operation, maintenance, or from incompatibility with other manufacturer's products.

LEXUS RC300 / RC350 RWD / AWD 15-18

GRIP CATBACK EXHAUST SYSTEM

INSTALLATION GUIDE



Important Information:

Exclusion of Certain Liability:

1. The manufacturer, importer, and dealer of ARK Performance products hold no responsibility for any incidental damage such as personal injury or any other damages due to improper installation or operation of an ARK Performance exhaust system. When installing an ARK Performance exhaust system, make sure the exhaust system does not touch other parts of the vehicle that are sensitive to high temperature.
2. ARK Performance will not warranty any damages caused by improper installation, use, and maintenance of the ARK Performance exhaust system. The warranty is limited to defects that are recognized by our technical department, this excludes items subject to normal wear such as the flange gaskets. This warranty is void in the case of an accident, modification, improper use, or competition use.
3. Do not install any ARK Performance exhaust system on a vehicle model for which it was not intended for.
4. The exhaust system will be very hot during and immediately after operation of the vehicle, please be careful not to burn yourself on the exhaust system or parts which are in direct contact with it. Also please protect other people, especially children, from any injuries due to the hot exhaust system.
5. Technical specifications of ARK Performance exhaust systems and related products are subject to change without notice.
6. Before removing the original exhaust system from your vehicle, please compare the parts that you received with the list of materials provided in the installation instructions. If anything is missing, contact ARK Performance before beginning installation.
7. The instructions for installation should serve as a guideline only, actual installation of exhaust systems may vary.
8. The process of uninstalling the original exhaust system may vary depending on the existing exhaust system so please follow the original exhaust system manufacturer's instructions for removal.
9. If there are any issues with installation (fitment or missing parts), please contact us right away before continuing. If the exhaust system is modified in any way, there is no refund or warranty.

Noise and Emission Warning:

Because of the world-wide distribution of ARK Performance products, neither ARK Performance nor any of its subsidiaries make any representation that the exhaust system complies with the air and/or noise emissions laws, or labeling laws, of any jurisdiction. The purchasers are entirely responsible for informing themselves of the applicable laws where the products are to be used and to comply with those law.

California laws prohibit the use of any aftermarket exhaust part or system that modifies, removes or replaces original equipment catalysts unless the California Air Resources Board has issued an Executive Order regarding such part or system or unless the part or system is exempted by being used only on racing vehicles on closed courses. Neither ARK Performance nor any of their subsidiaries make any representation that any of their parts or systems has received such an Executive Order or that any of their parts or systems conform with the racing vehicles exemption. The purchasers are entirely responsible for informing themselves of applicable California laws and to comply with those laws. CA Residents: This product may expose you to chemicals including nickel (metallic) and chromium (hexavalent compounds) which are known to the State of California to cause cancer. Learn more at: <https://www.p65warnings.ca.gov/>

Various U.S. states and the U.S. federal government have individual laws regulating the use of aftermarket exhaust parts and systems, especially as those parts and systems modify, remove, or replace original equipment catalysts. Please consult the appropriate laws in your area before installing any aftermarket part or system on your vehicle to ensure compliance with all applicable laws. Neither ARK Performance nor any of their subsidiaries or the sellers of the parts or systems make any representation that any of their parts or systems comply with any such laws.

Trademarks The ARK Performance logo is a registered trademark of ARK Performance Inc. USA.

Copyright

No part of the ARK Performance exhaust system or its documentation may be reproduced or distributed in any form or by any means without the authorization and permission from ARK Performance Inc. USA.

© ARK Performance Inc. USA. All rights reserved.

LEXUS RC300 / RC350 RWD / AWD 15-18

GRIP CATBACK EXHAUST SYSTEM

INSTALLATION GUIDE

Included Parts:

- 1x Driver Side Muffler / Exhaust Tips
- 1x Passenger Side Muffler / Exhaust Tips
- 1x Driver Side Rear Mid Pipe
- 1x Passenger Side Rear Mid Pipe
- 1x X-Pipe
- 1x Driver Side Front Pipe
- 1x Passenger Side Front Pipe
- 6x 2.5" Gaskets
- 12x Nut/Bolt

Tools Needed:

- Socket Wrench/Wrench:
 - 10 mm
 - 12 mm
 - 14 mm
- Socket Wrench Extension
- O2 Sensor Remover
- Lubricant (WD-40)
- Hanger Remover
- Exhaust Stand
- One or two helpers
- Flat head screwdriver
- Clip Remover

Estimated Installation Time:

- 1 - 2 hours

 The following guide features images from the RC350 2017 RWD model and may show technicians using power tools. Hand tools will work perfectly fine. Your vehicle's appearance and installation may differ, however, the basic concept and installation will be very similar if not the same.

BEFORE YOU INSTALL:

- ***IMPORTANT*** If any items in the package are missing please contact ARK or your authorized dealer before installation.
- Before removing the original exhaust system, be sure to give sufficient time for the exhaust piping and surrounding parts to cool down. They can be extremely hot!
- We highly advise to have an experienced person or certified mechanic install the exhaust system.
- Raise vehicle only on certified jack stands or on a vehicle lift.
- Please properly dispose of any and all liquids and excess parts that may be produced as a result of removing the existing exhaust system.
- While installing the new system, do not fully tighten nuts and bolts. Begin by loosely fastening all nuts and bolts until everything is installed, then tighten them down to the proper torque specs as you align the exhaust system for best fitment.



LEXUS RC300 / RC350 RWD / AWD 15-18

GRIP CATBACK EXHAUST SYSTEM

INSTALLATION GUIDE

OEM/STOCK EXHAUST REMOVAL:

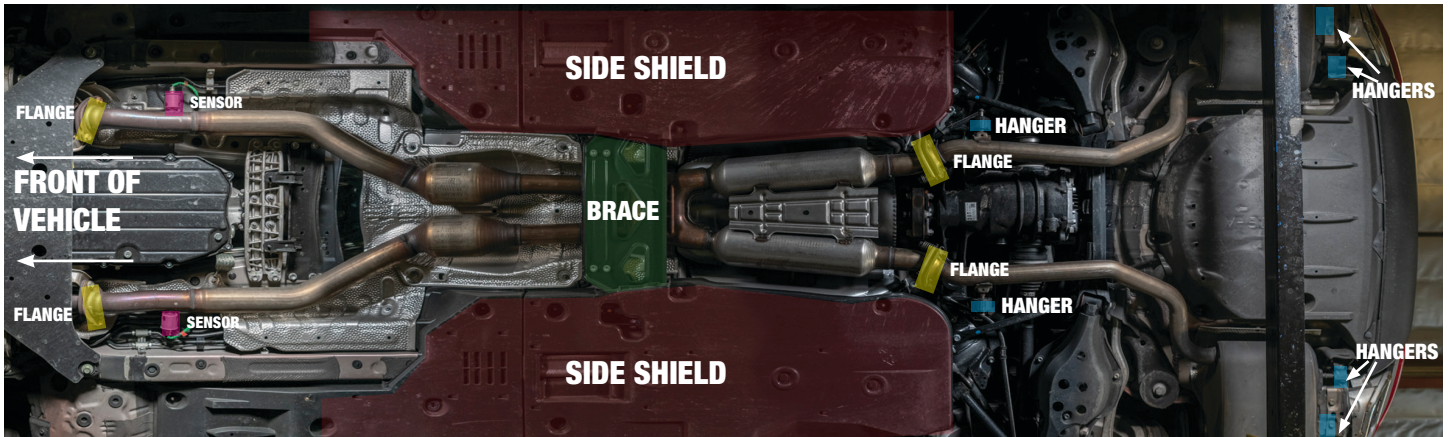

FIG. 1



FIG. 2

FIG. 3

1. Once your vehicle has been lifted, you will need to remove the center brace. Start by removing the clips (Fig. 2) and un-bolting (Fig. 3) the side shields. The side shields do not need to be removed. They need to be loose so that you can access the bolts holding up the brace .

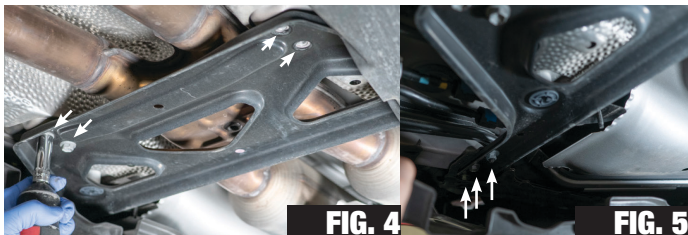

FIG. 4

FIG. 5

2. Unbolt all the bolts holding the brace (Fig. 4). There are several nuts that need to be unfastened that are covered by the side shields (Fig. 5).



FIG. 6

3. You will encounter these plastic pieces (Fig 6). Use a flat head screw driver to unscrew the from the shielding above it. Once these pieces are removed, carefully remove the brace.

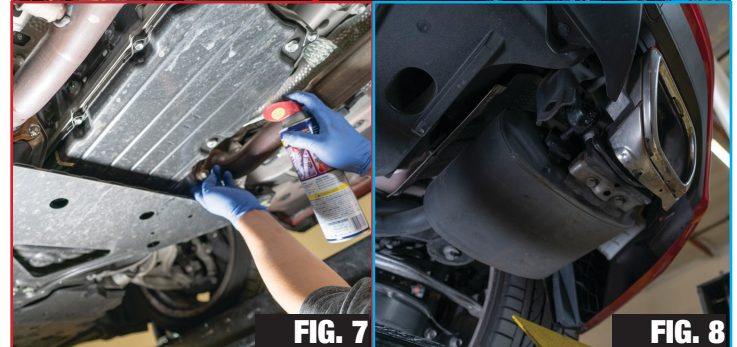
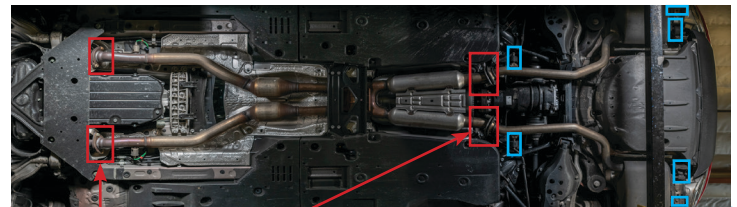

FIG. 7

FIG. 8

4. Using your choice of lubricant, lubricate all nuts/bolts on the four flanges (Fig 7) and the six rubber insulators/hangers (Fig 8).

LEXUS RC300 / RC350 RWD / AWD 15-18

GRIP CATBACK EXHAUST SYSTEM

INSTALLATION GUIDE

OEM/STOCK EXHAUST REMOVAL(CONT.):

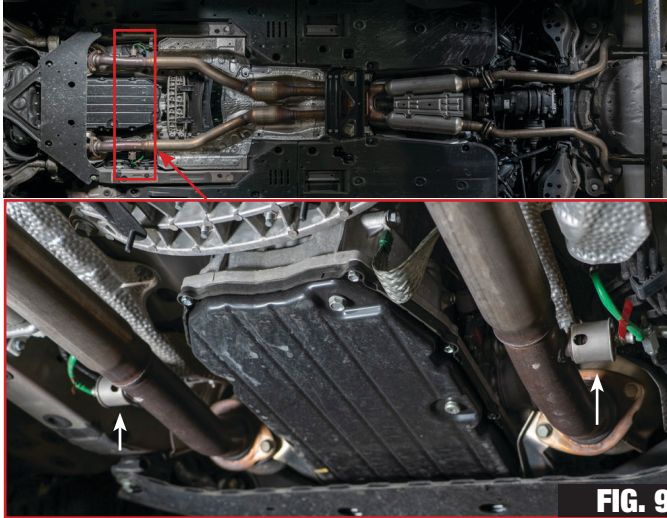

5. Remove the two sensors near the front flange of the vehicle using a sensor remover (Fig 9).

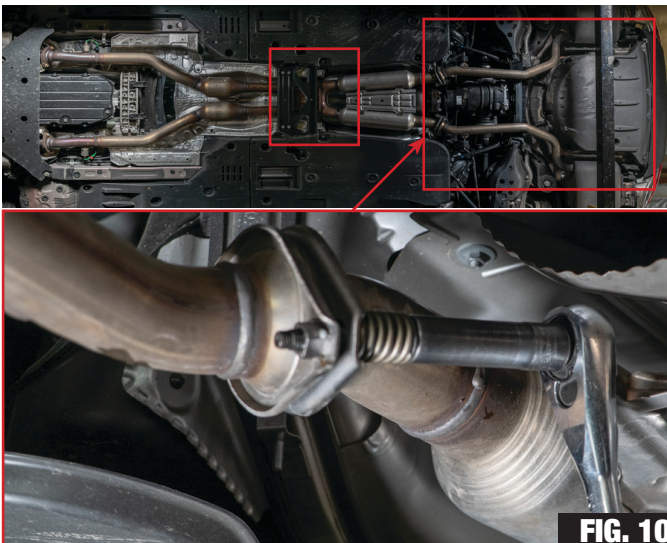

6. Use an exhaust stand to prop up the exhaust near where the the brace was located. Unbolt one of the flanges leading to the muffler (Fig 10). Carefully remove the exhaust hangers from the rubber insulators using a hanger remover. Leave the rubber insulators on the vehicle's hangers. Remove starting from the flange and working back towards the muffler.

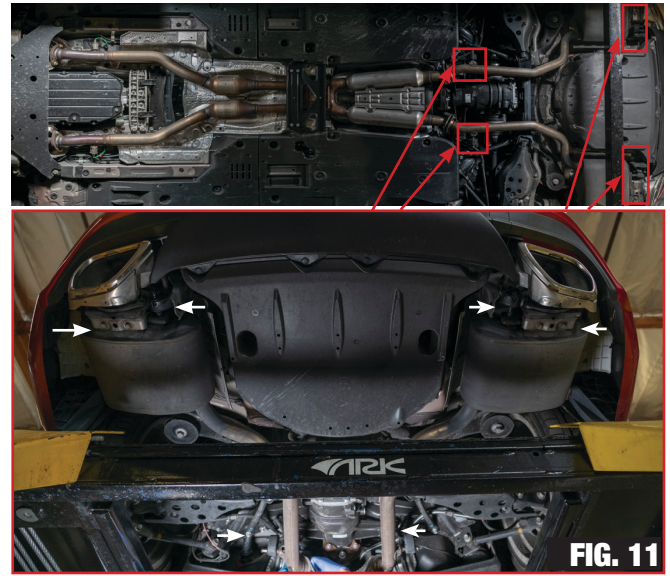

7. Remove the muffler portion of the exhaust one at a time. Starting near the flange, carefully remove the hangers from the rubber insulators using a hanger remover (Fig 11). Remove the rearmost two hangers from their rubber insulators. The muffler portion should come free.

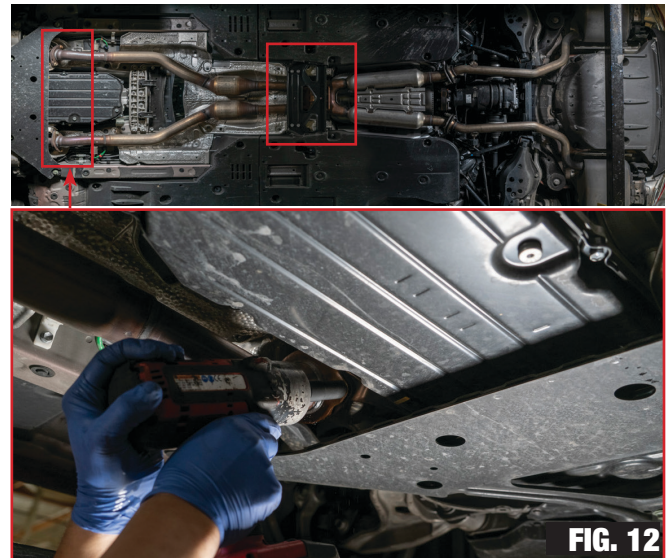

8. Have a helper or friend hold the section of the exhaust near the area where the brace used to be. Remove the exhaust stand, and unbolt the nuts from the front flanges (Fig 12). Carefully remove the remaining stock exhaust.

LEXUS RC300 / RC350 RWD / AWD 15-18

GRIP CATBACK EXHAUST SYSTEM

INSTALLATION GUIDE



ARK GRIP EXHAUST INSTALLATION:

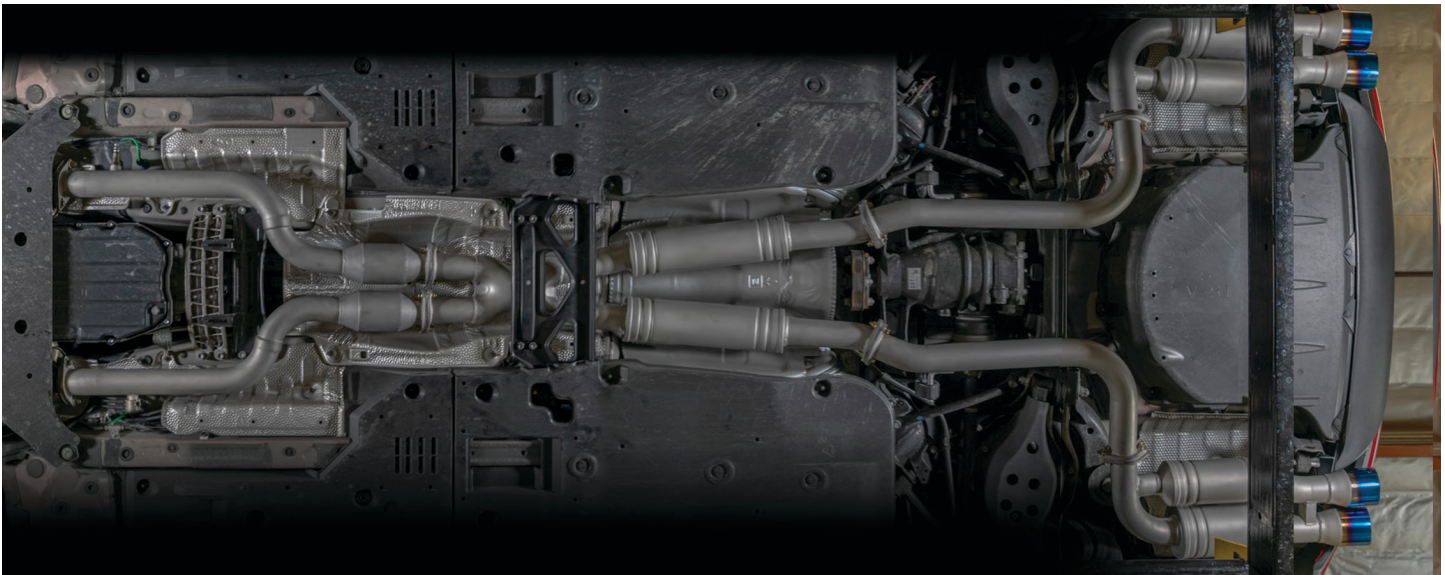
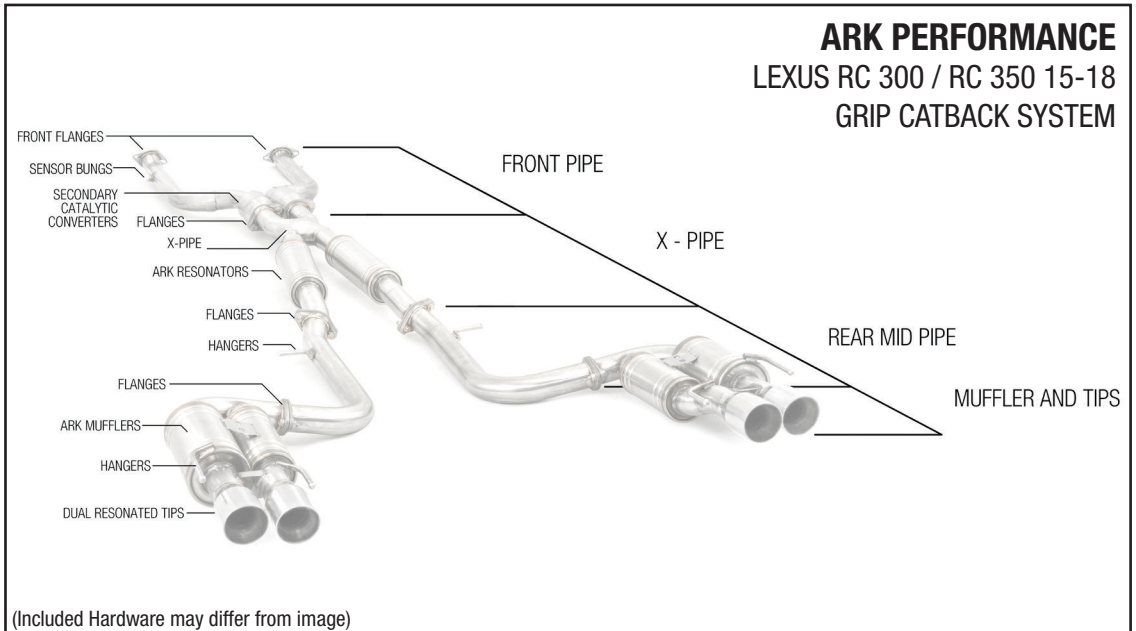

LEXUS RC300 / RC350 RWD / AWD 15-18

GRIP CATBACK EXHAUST SYSTEM

INSTALLATION GUIDE

ARK GRIP EXHAUST INSTALLATION

(CONT.):

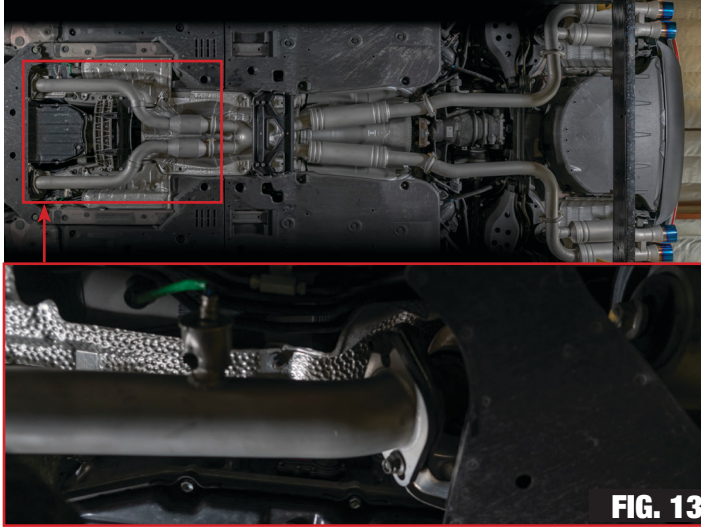

1. Bolt on the front flanges using the factory gaskets (Fig 13), and use the sensor remover to install the sensors into the bung holes. The flanges should hold the weight of the front pipes.

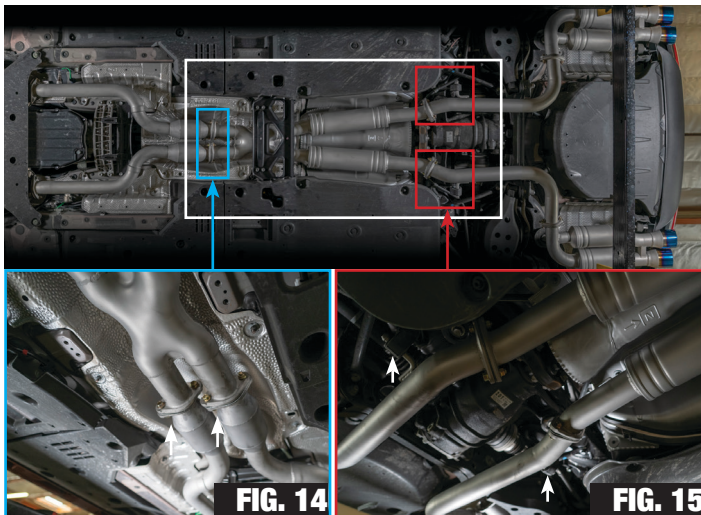

2. Before placing them under the vehicle, assemble the X-pipe with the two rear mid pipes by bolting the two pieces together first. Be sure to use the included gaskets and nuts/bolts. Once the X-pipe and two rear mid pipes are attached together, align them under the vehicle, and insert the hangers on the rear mid pipe section into the rubber insulators (Fig 15). Using the included gaskets, bolt the X-Pipe Flanges onto the two front pipes (Fig 14).

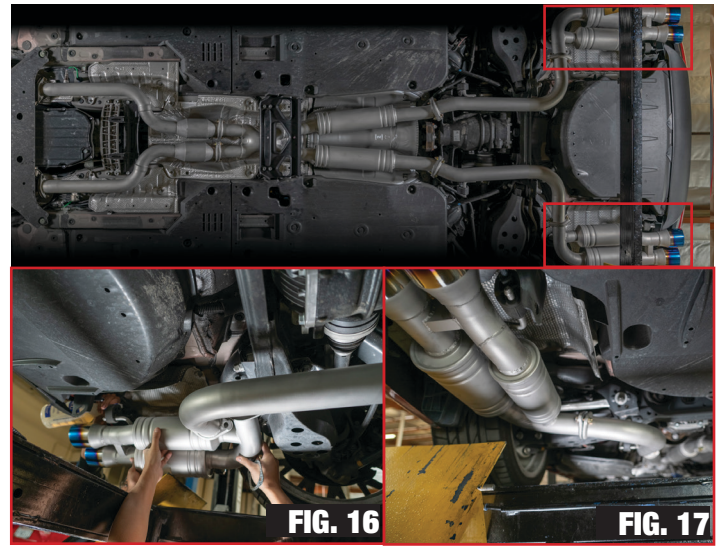

3. To install the rear mufflers, first insert each of the metal exhaust hangers into the appropriate rubber insulators (Fig 16). Line up the muffler flange to the rear mid pipe flange. Insert the gasket and install the nuts and bolts (Fig 17).

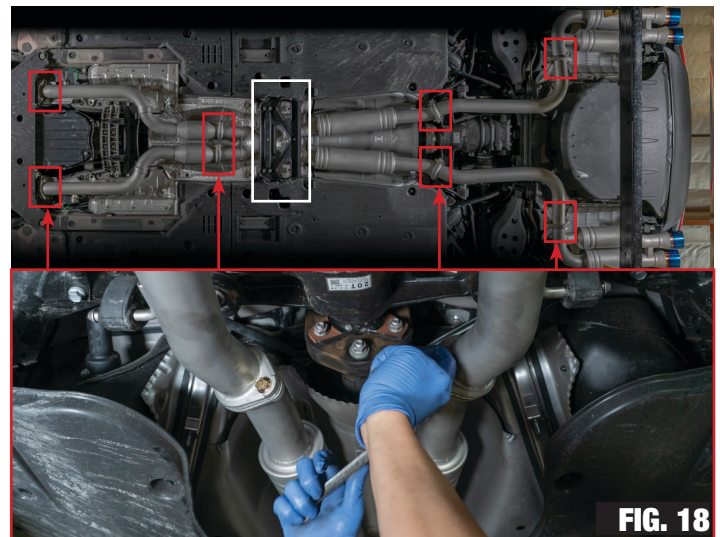

4. Align the tips in the rear of the system by carefully pushing the flanges of the system into place. Then, starting from the front of the vehicle move your way to the rear of the vehicle while tightening the nuts and bolts on the system (Fig 18). Be sure to keep an eye on the tip alignment. Once the exhaust has been fully installed, reinstall the center brace, and then bolt up the side shielding.

LEXUS RC300 / RC350 RWD / AWD 15-18

GRIP CATBACK EXHAUST SYSTEM

INSTALLATION GUIDE



First Operation of Vehicle with ARK Performance Exhaust:

- Before starting the vehicle, be sure that no part of the exhaust system is touching a heat sensitive area or an area that will cause a rattle and vibration.
- It is normal to have white smoke and a slight burning smell come from the exhaust system upon first start up and operation. These will eventually go away after 50 miles or more of driving.
- Be sure to check that there are no exhaust leaks, this can be done by revving the motor in neutral to 2,000-2,500 rpm and listening to the piping for any leaks.

Maintenance:

- Please **DO NOT USE any acidic chemicals or abrasive materials** when cleaning your ARK Performance exhaust system.



- We recommend that you **ONLY USE water and/or automotive soap** when cleaning the Burnt or Tecno tip finishes. **Other chemicals or polishing products MAY REMOVE any finishes.**

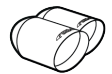

- It is recommended to check the nuts and bolts periodically to make sure they have not come loose, re-tighten them if necessary.

