

# ASSEMBLING GUIDE

Dining Table

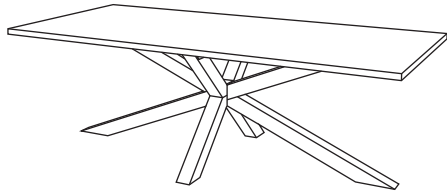

## Material used

Wood : Rustic  
Iron : Black

# DINING TABLE 220-300

XONO

assembling guide

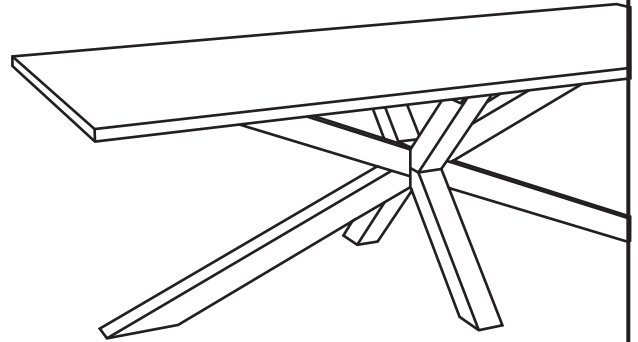

**Bodhi**<sup>®</sup>

dbodhi.com

## Box Content

- a. Top table 1 pc
- b. Legs 4 pcs
- c. Leg Connector 4 pcs
- d. Wooden pin 1 pc
- e. Bolts rings and nuts M8x100mm : 4 pcs
- f. Bolts rings and nuts M8x120mm : 4 pcs
- g. Screw 16 pcs
- h. Tool 2 pc
- i. Allen key 1 pc

PERSON NEEDED

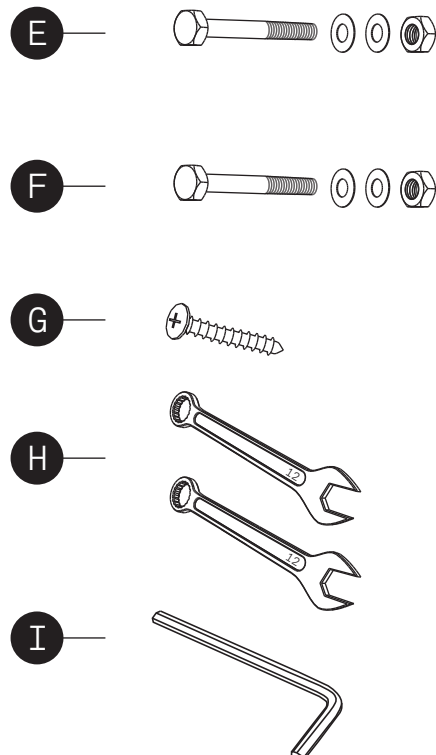
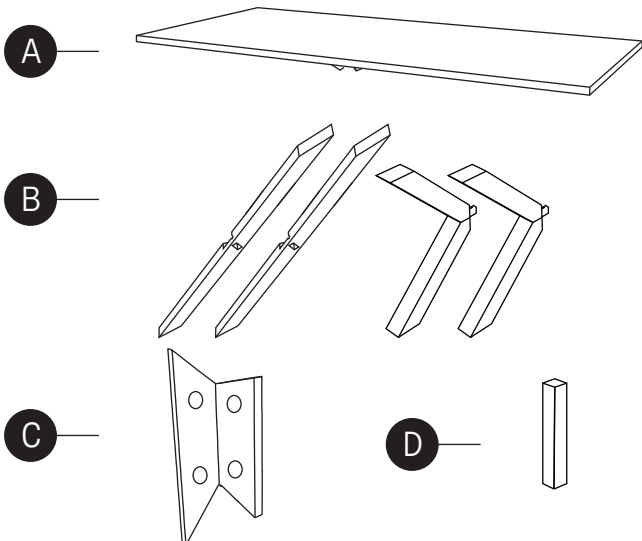

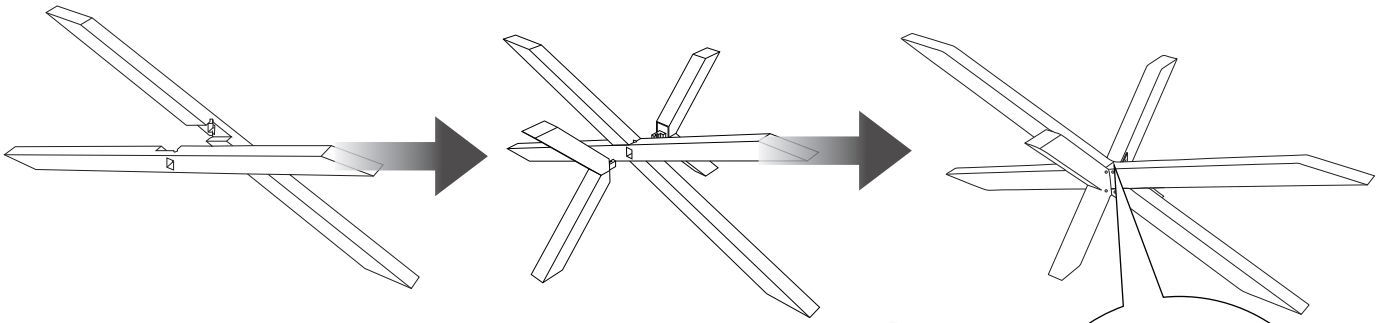

1. Place the table components as shown above and lock the leg as in detail (i)

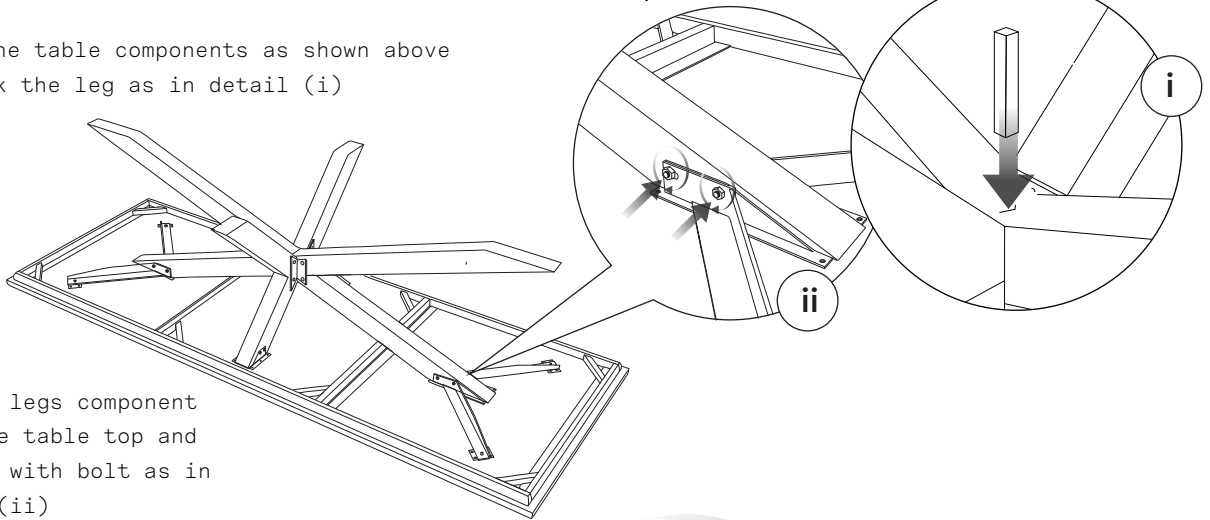

2. Put the legs component into the table top and tighten with bolt as in detail (ii)

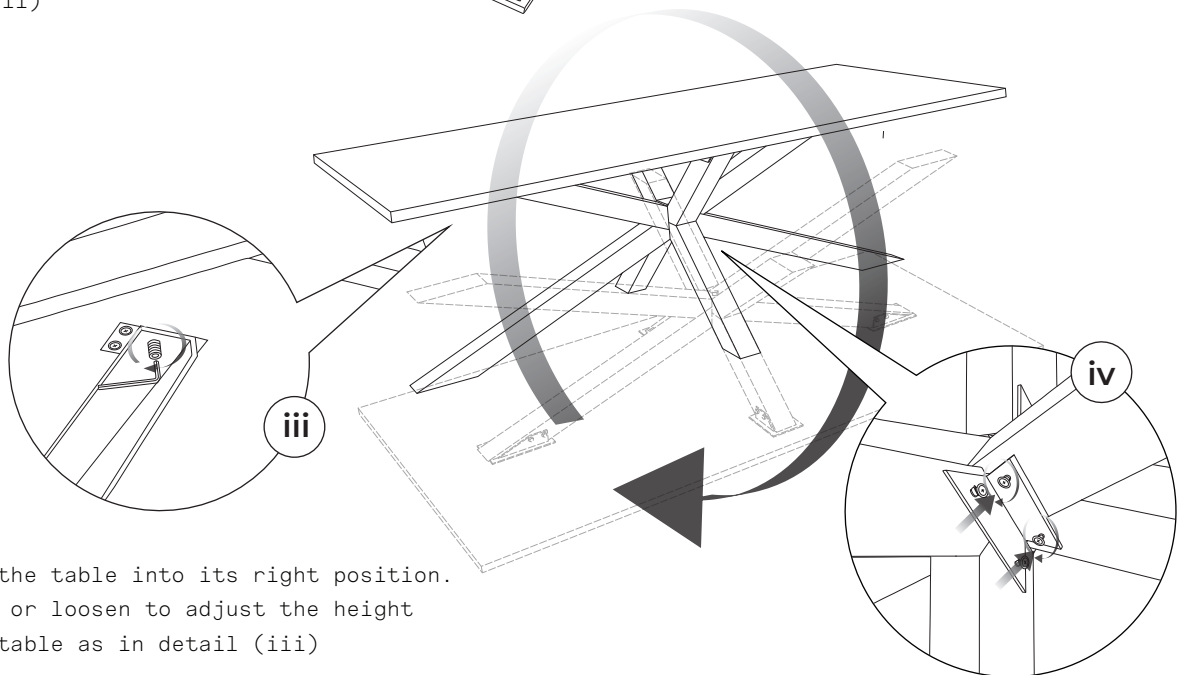

3. Rotate the table into its right position. Tighten or loosen to adjust the height of the table as in detail (iii)

4. After the table on its right position, instal the leg connector and tighten with screw as in detail (iv)

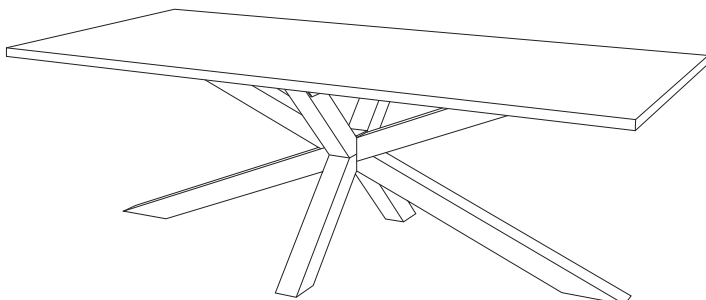

5. Your Dining table is ready.