

# Tip Toe

Assembly instructions

WENDELBO

## Please note

Please read these instructions carefully and keep them for future reference. Refer to the parts inventory and ensure you have all the parts before starting. During assembly, place all parts on a flat, soft and clean surface, such as a carpet or blanket, to prevent scratches and damage. We recommend that a minimum of two people help each other to assemble.

## Parts inventory

A Seat frame

B Square metal leg

C L-shape metal legs

D Horizontal metal bar

E Bolts

E Allen key



## Assembly

1.

Place part B (square metal Leg) to part A (seat frame), insert part E (metal bolts) by 2 pcs., use part F (allen key) to tighten. Do not tighten well all the metal bolts until everything is in place and make sure to align the metal legs.

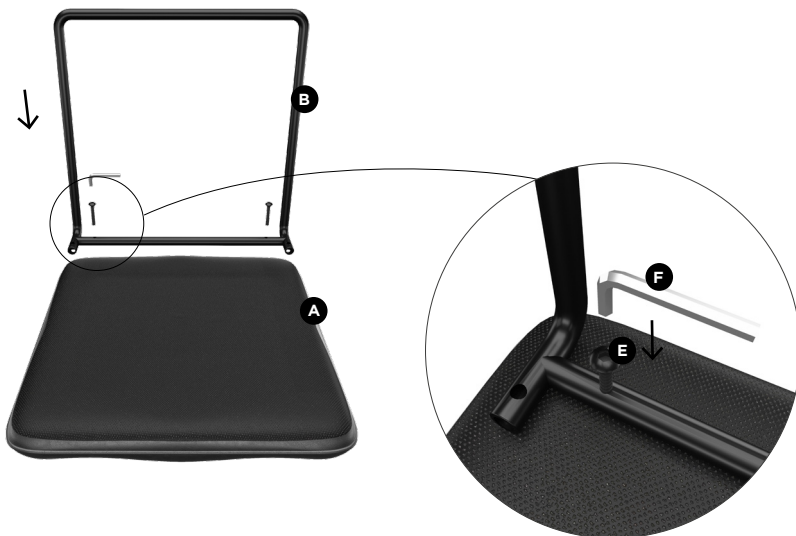

2.

Insert part C (L-shape metal Legs) to part A (seat frame) & part B (square metal leg) with part E (metal bolts) by 8 pcs., use part F (allen key) to tighten. Do not tighten well all the metal bolts until everything is in place and make sure to align the metal legs.

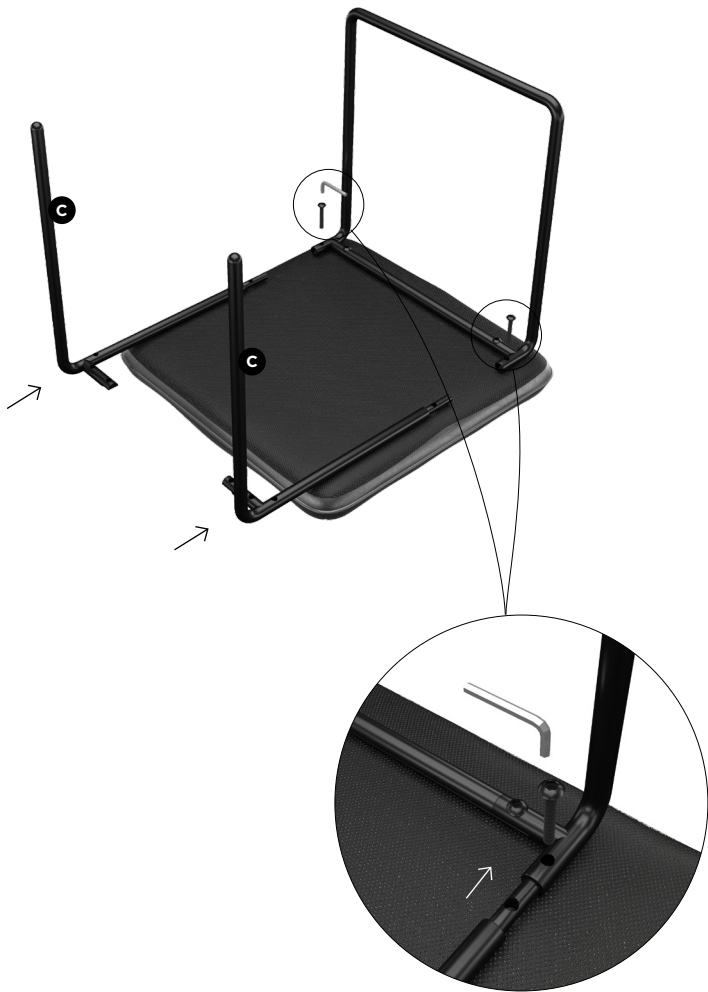

3.

Align part A (seat frame), part B & C & D (metal legs) properly and tighten all part E (metal bolts) by using part F (allen key).





WENDELBO

