











Slab Console

ASSEMBLY INSTRUCTIONS

LIST OF HARDWARE

1	 M6 x 30	08 pcs
2	 M6 x 35	06 pcs
3	 M6 x Ø18	08 pcs
4	 M6 x Ø30	08 pcs
5	 M6	02 pcs
6		02 pcs
7		01 pc
8		01 pc

 10 MIN  x2



A x 1pc



B x 1pc



C x 2pcs

Step 1

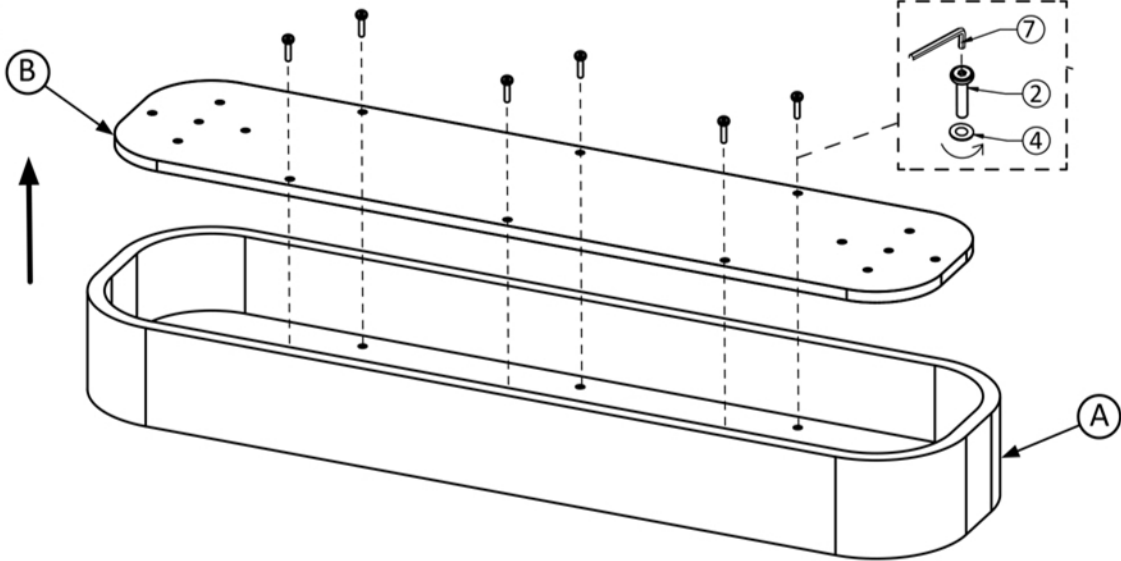

Step 2

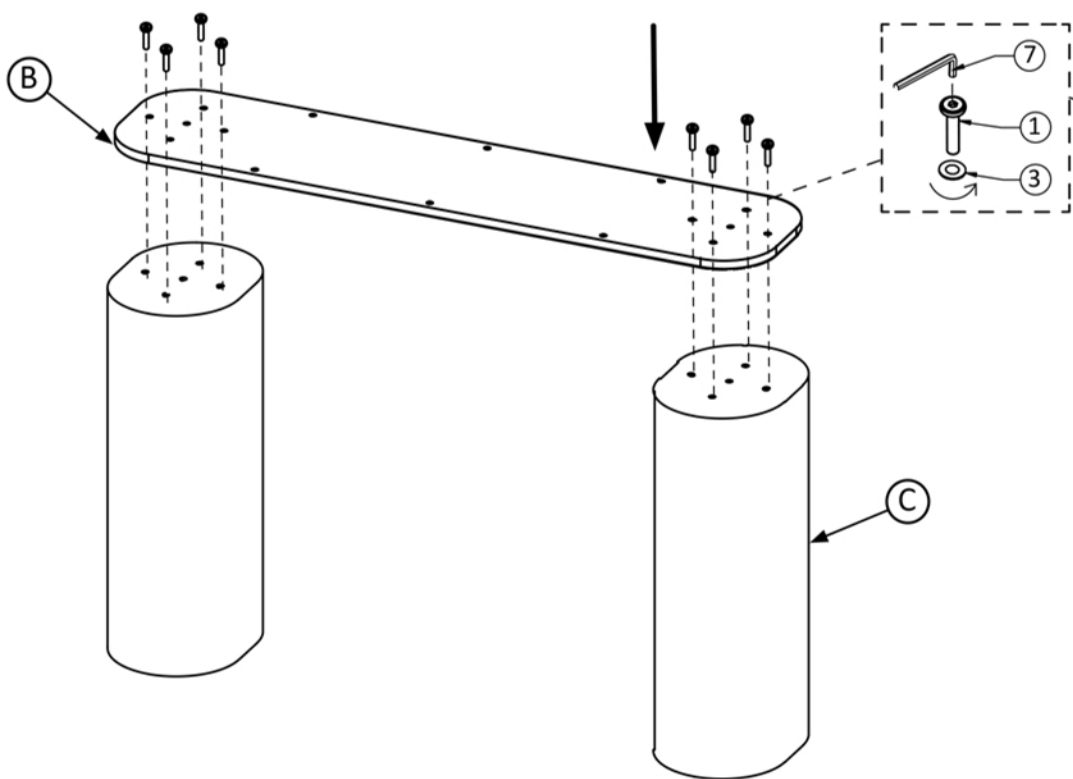

Slab Console

ASSEMBLY INSTRUCTIONS

Step 3

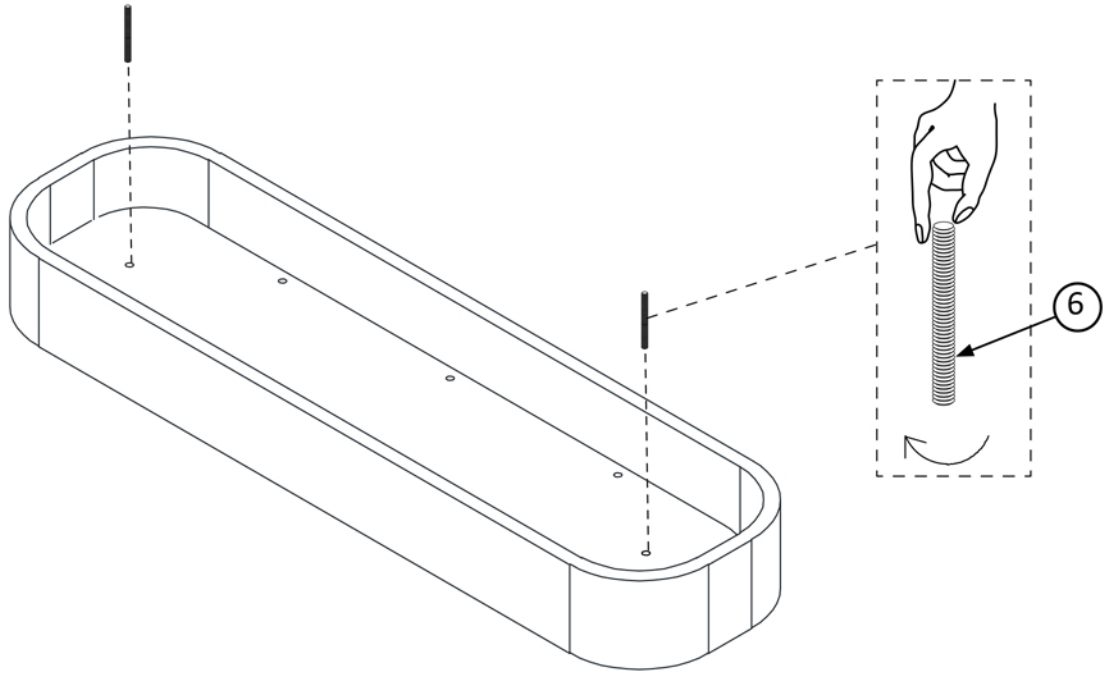

Step 4

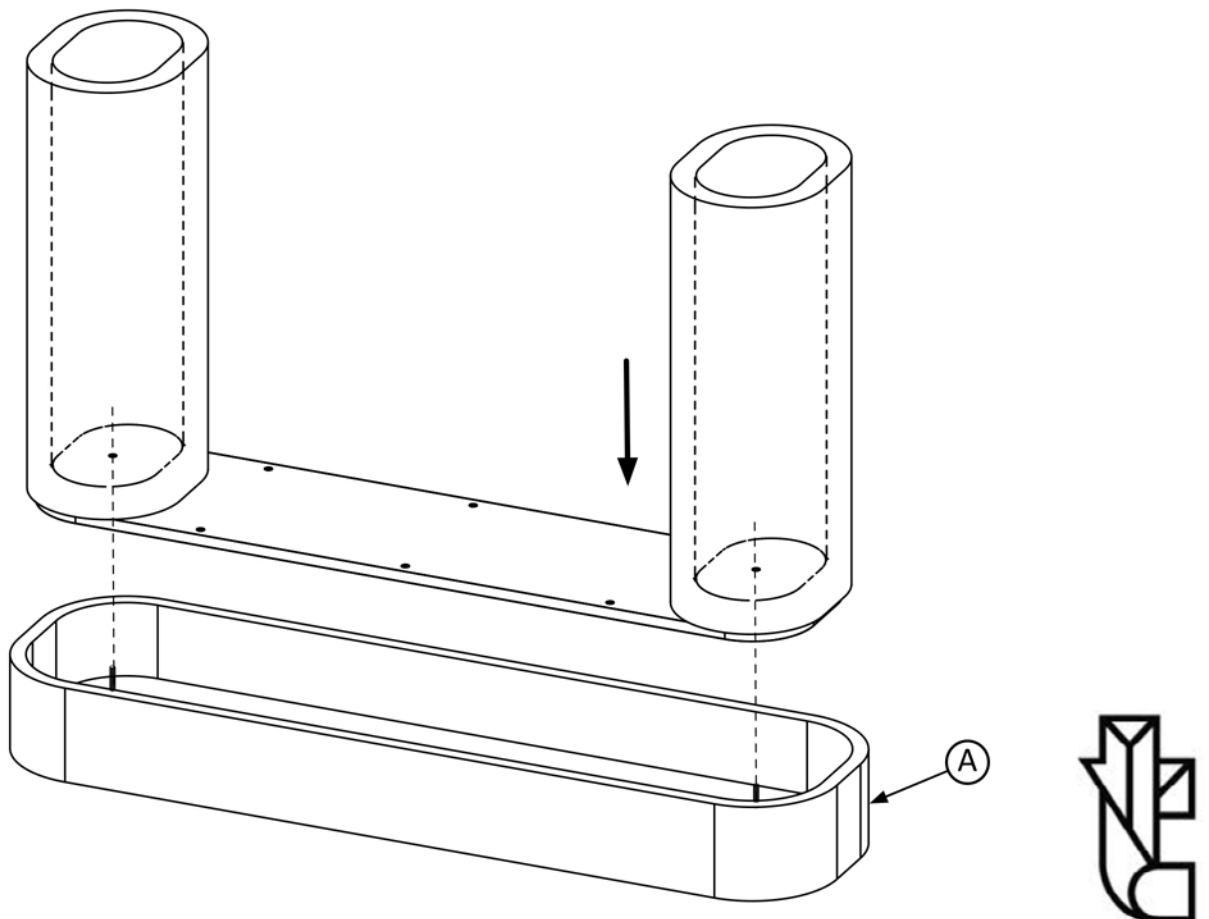

Slab Console

ASSEMBLY INSTRUCTIONS

Step 5

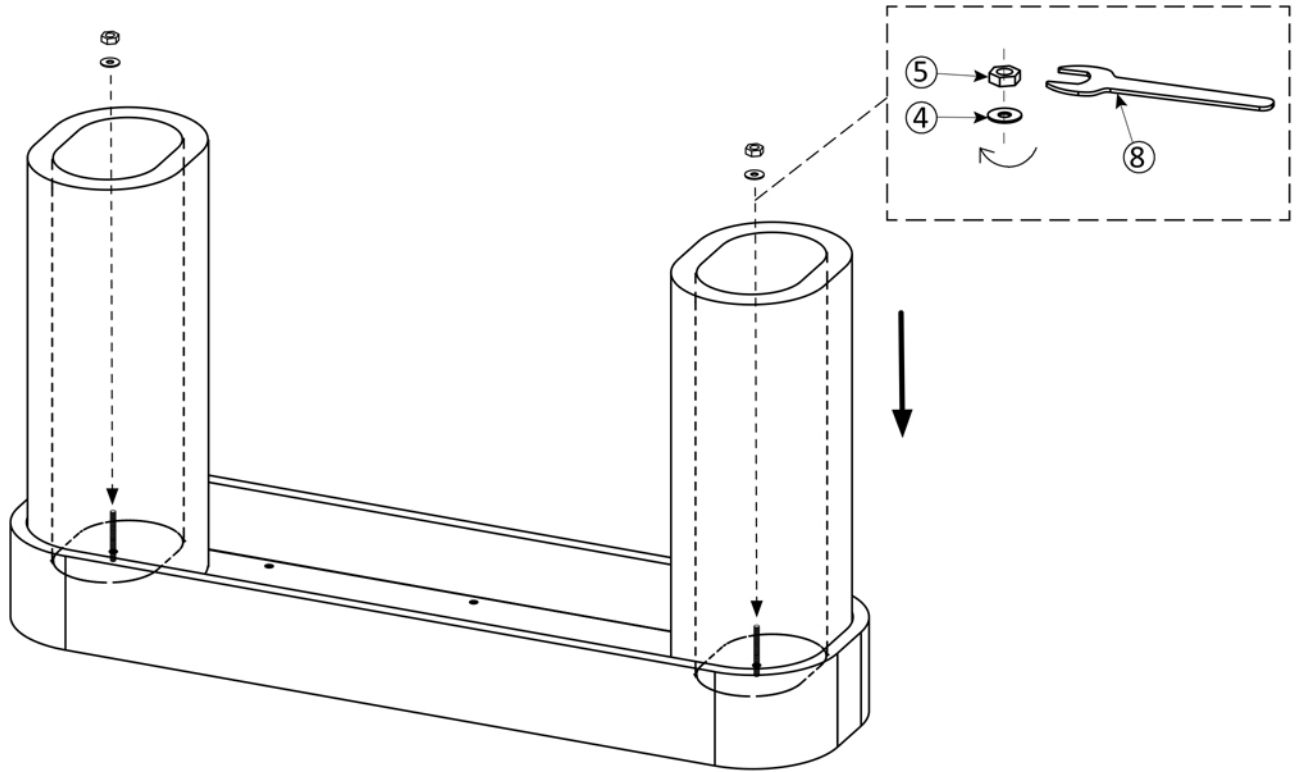

Step 6

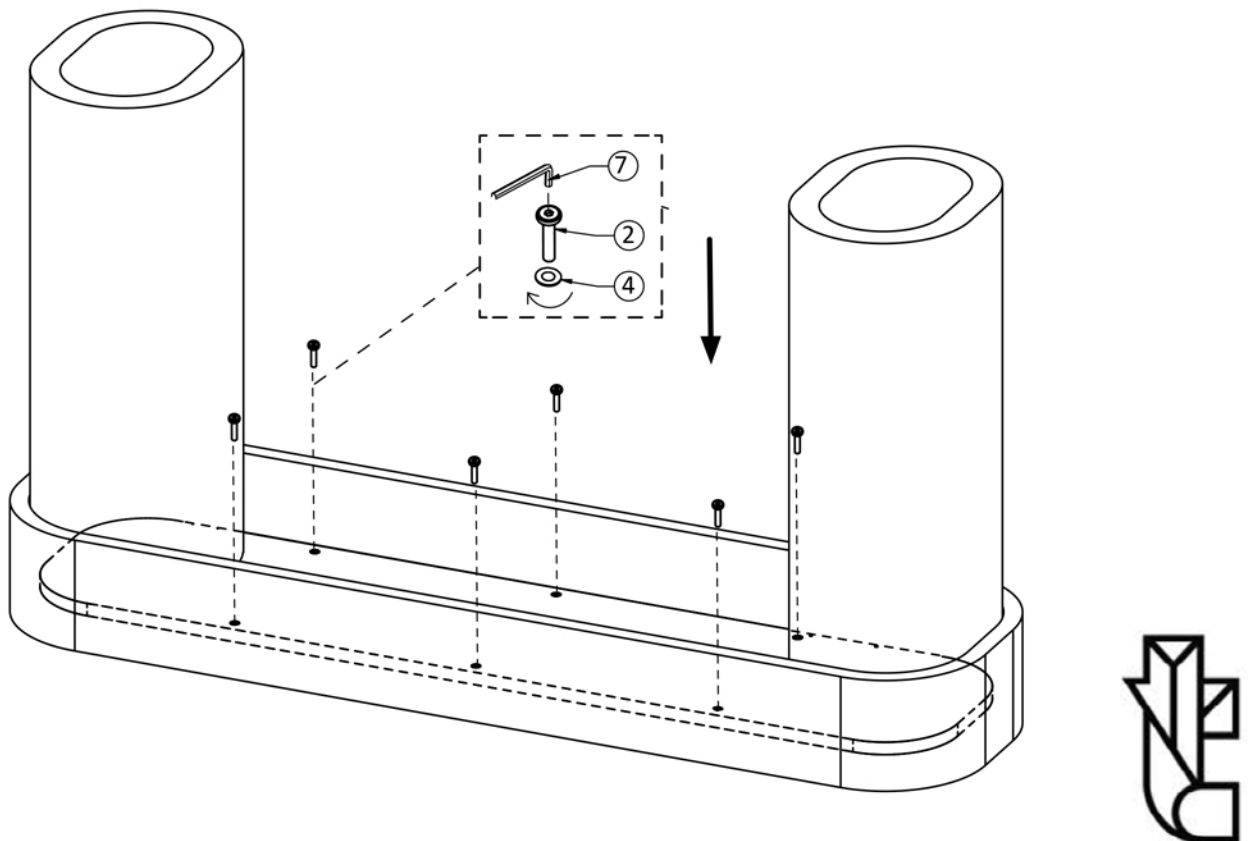

Slab Console

ASSEMBLY INSTRUCTIONS

Finished

