

ASSEMBLING GUIDE

Writing Desk

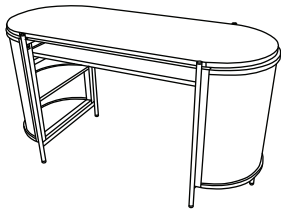

Material used

Wood : Finishing Not Polish
 Iron : Black Doff

Box Content

- a. Primary top 1 pc
- b. Secondary top 1 pc
- c. Side part 2 pcs
- d. Shelves 2 pcs
- e. Hex screw JCBC M6x30mm : 4 pcs
- f. Allen key 1 pc
- g. Ring and bolt M6x20mm : 6 pcs
- h. Ring and bolt M6x40mm : 6 pcs
- i. Tool 1 pc

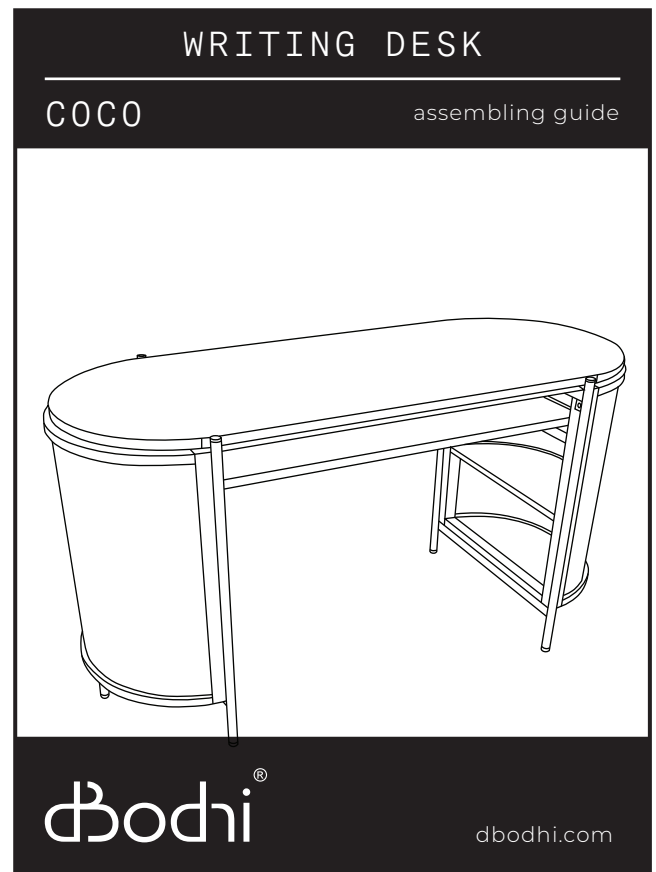
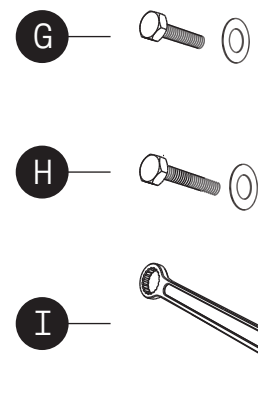
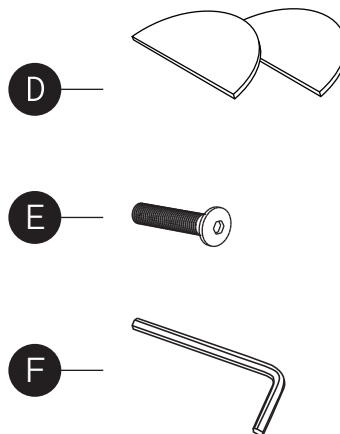
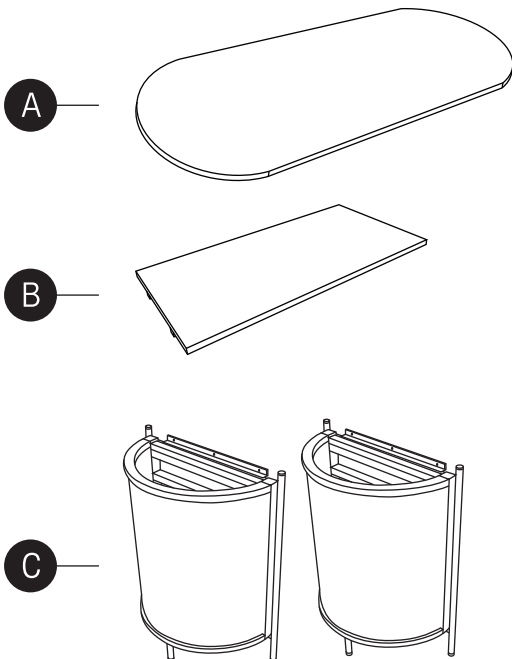

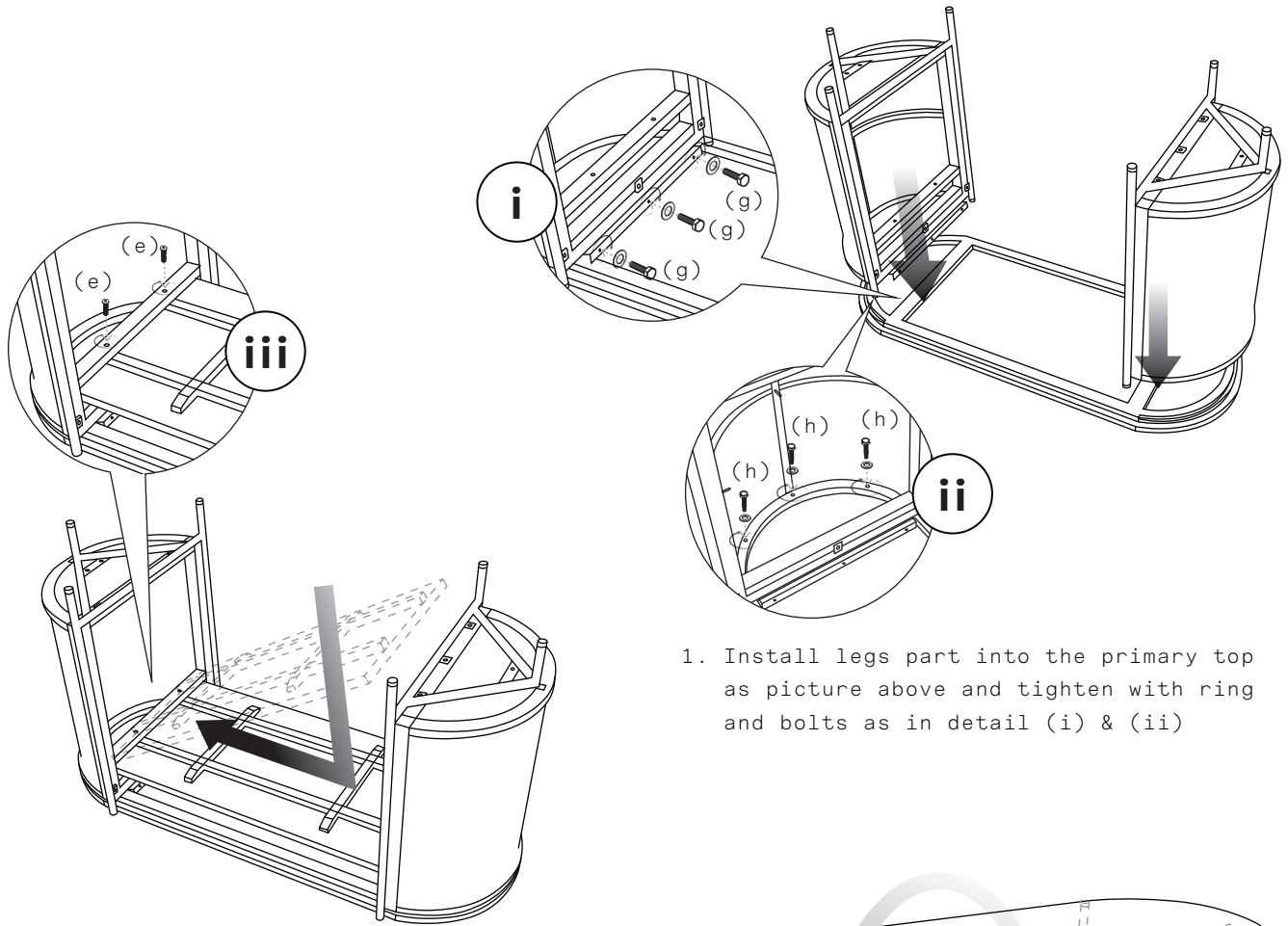

1. Install legs part into the primary top as picture above and tighten with ring and bolts as in detail (i) & (ii)

2. Install secondary top like picture above and tighten with hex screw as in detail (iii)

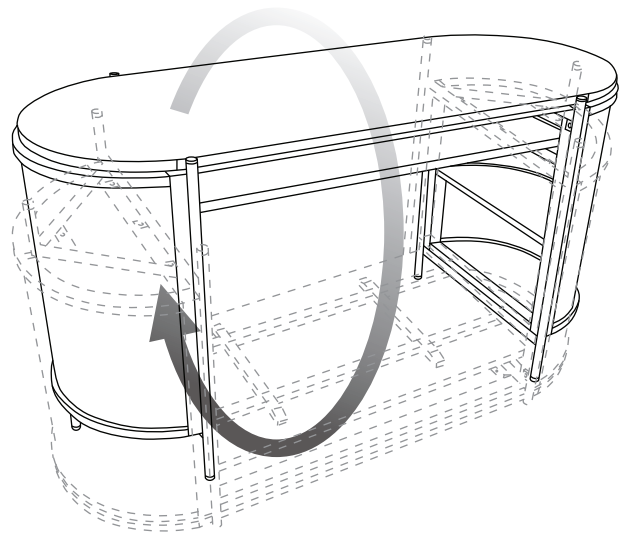

3. Rotate the table into its right position.

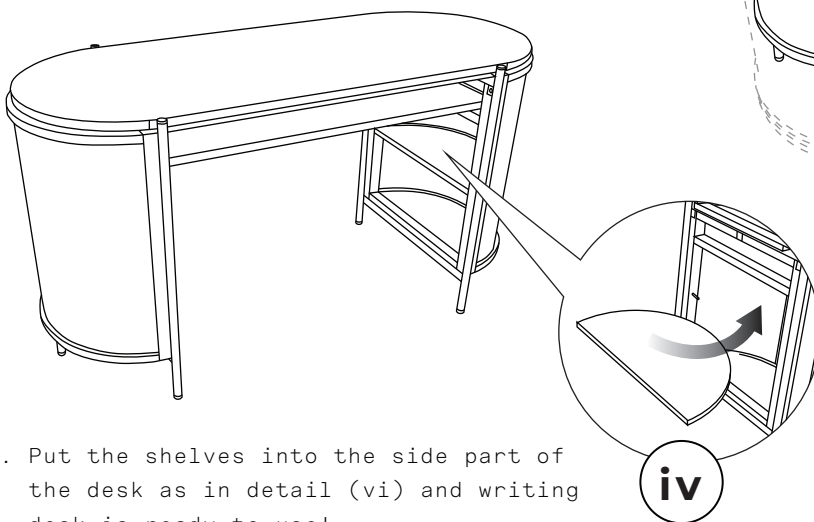

4. Put the shelves into the side part of the desk as in detail (vi) and writing desk is ready to use!