



WENDELBO

DESIGN BY 365 NORTH

SLICE  
MEDIUM, MEDIUM

ASSEMBLY INSTRUCTION



Please read these instructions carefully and keep for future reference. Refer to parts inventory for guidance and ensure you have all pieces before starting.

When assembling, place all parts on a soft, clean and flat surface such as a carpet to prevent scratches.

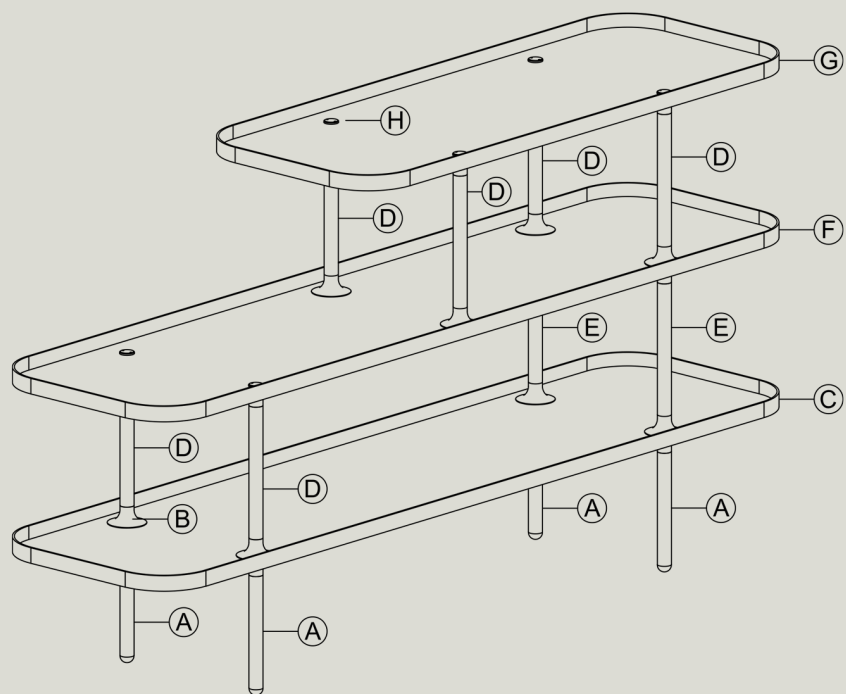

## PART INVENTORY

| ID | DESCRIPTION     |   | QTY | DIM     |
|----|-----------------|---|-----|---------|
| A  | LEG             |    | 4   | 268 MM  |
| B  | CURVED SOCKET   |    | 20  | -       |
| C  | ALUMINIUM SHELF |    | 1   | 1400 MM |
| D  | HEIGHT SUPPORT  |    | 6   | 205 MM  |
| E  | HEIGHT SUPPORT  |    | 2   | 287 MM  |
| F  | ALUMINUM SHELF  |    | 1   | 1400 MM |
| G  | ALUMINUM SHELF  |    | 1   | 950 MM  |
| H  | BRASS BOLT      |    | 8   | -       |
| I  | SPAN WRENCH     |  | 1   | -       |
| J  | WALL BRACKET    |  | 2   | -       |
| K  | SCREW           |  | 2   | -       |
| L  | WASHER          |  | 2   | -       |

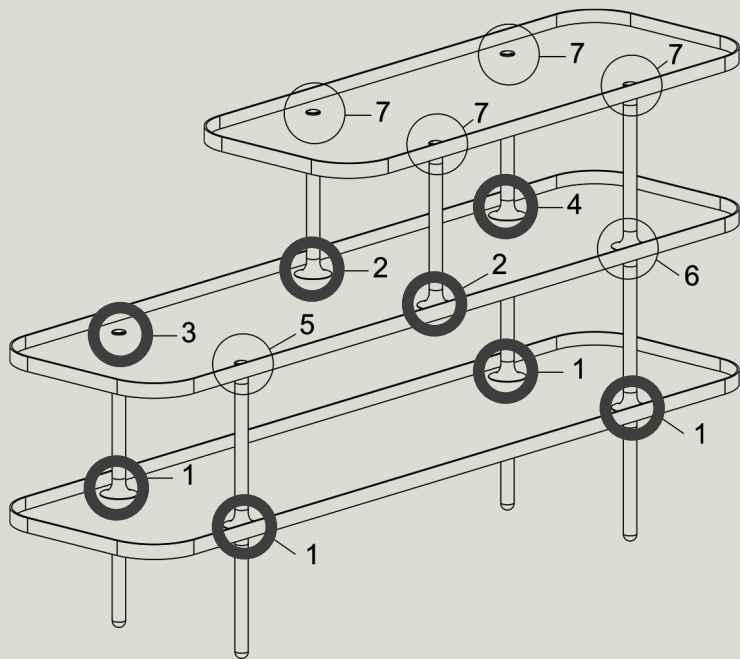

**1**

Put curved socket > aluminum shelf > curved socket into the leg.

Then turn height support around to tighten the joint.



**2**

Put brass bolt and curved socket to the hole of the aluminum shelf.

Turn height support around to tighten the joint.

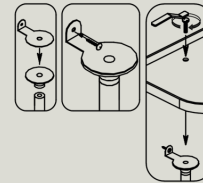

**3 (IF WALL-MOUNT)**

Put curved socket and bracket into the joint.

Attach screw to the wall by using a screwdriver.

Put aluminum shelf and brass bolt to the joint.  
Turn span wrench around to tighten the joint.

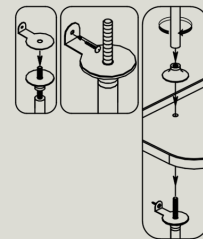

**4 (IF WALL-MOUNT)**

Put curved socket and bracket into the joint.

Attach screw to the wall by using a screwdriver.

Put aluminum shelf and curved socket to the joint.  
Turn height support around to tighten the joint.

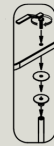
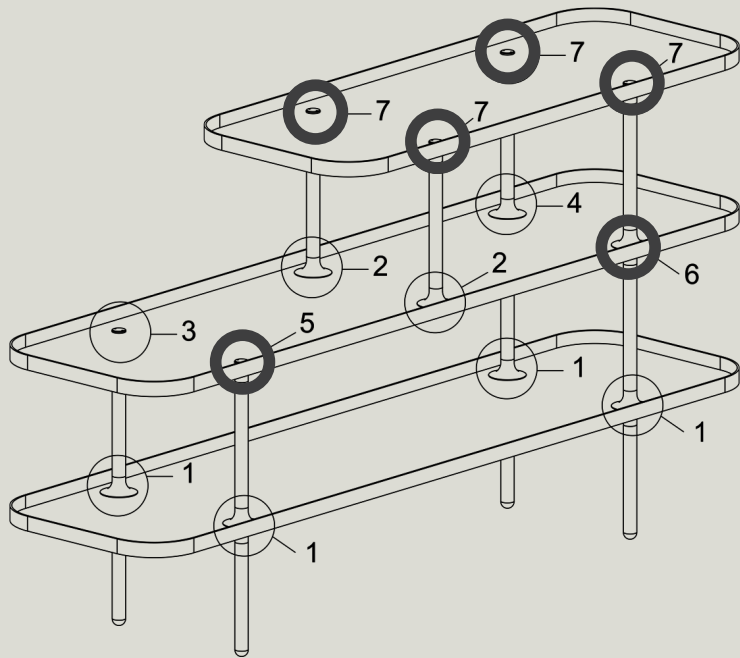

5

Put curved socket > washer > aluminum shelf > curved socket into the joint. Then turn span wrench around to tighten the joint.

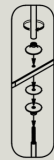

6

Put curved socket > washer > aluminum shelf > curved socket into the joint. Then turn height support around to tighten the joint.

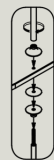

7

Use span wrench and brass bolt to attach aluminum shelf and curved socket to the joint.

**WWW.WENDELBO.DK**

WENDELBO INTERIORS A/S  
MOSEVEJ 20 A  
DK - 8240 RISSKOV  
DENMARK