

6

5

4

3

2

1

Brake Rotor Mtg Screws
6x M8 x 1.25 threads

Brake Rotor Mtg BCD
80.0 mm
3.150 in

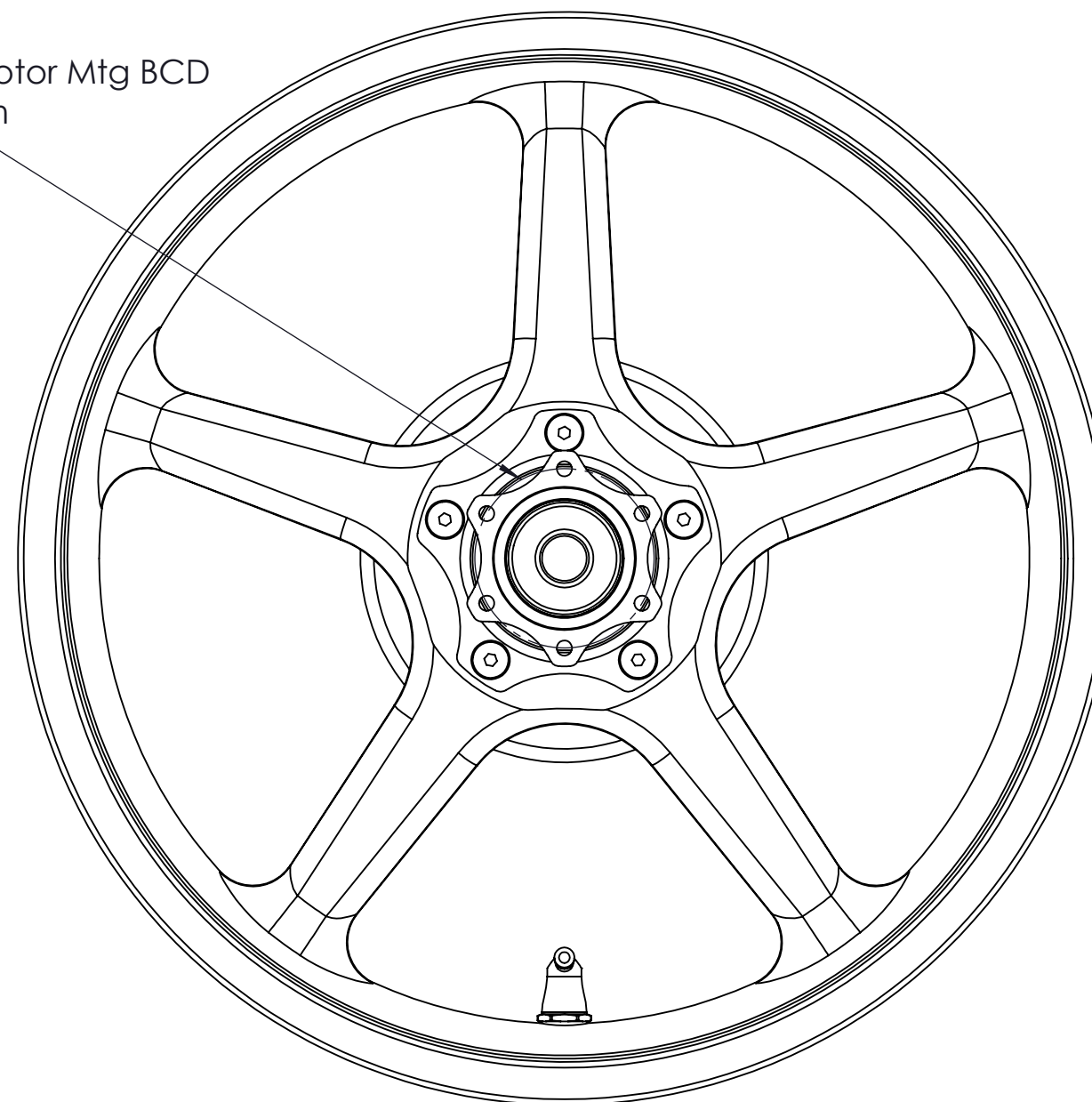

Specs - W50-5500 - Twin TEK Rear:

- SIZE : 18.0" x 5.5"
- BRAKE ROTOR BCD : 80.0 mm (3.150 in)
- WEIGHT : 11.70 lbs
- STATIC LOAD RATING : 902 lbs
- APPROVALS : DOT E and JWL for street and track use
- WARRANTY : 2 Years

Notes

1. PARTS TO BE FREE OF BURRS, NICKS, SCRATCHES, COLOR DEFECTS, OILS, AND SOLVENTS.
2. PARTS TO BE PACKAGED IN SUCH A WAY TO PREVENT DAMAGE.
3. ALL SHARP EDGES TO BE BROKEN TO .0075" RADIUS UNLESS OTHERWISE NOTED.

INCH		THIRD ANGLE PROJECTION	DRAWN BY DA	DRAWN DATE 2024.04.25	
			ENG Approval	APPROVED DATE	
TOLERANCES UNLESS OTHERWISE SPECIFIED 1 PLACE DECIMAL X.X ± 0.030 2 PLACE DECIMALS X.XX ± 0.010 3 PLACE DECIMALS X.XXX ± 0.005 ANGLES ± .5° ALL DIMENSIONS ARE INCHES UNLESS OTHERWISE SPECIFIED INTERPRETATIONS OF THIS DRAWING PER ASME Y19.94M			MFG Approval	APPROVED DATE	DRAWING NUMBER
			MATERIAL carbon fiber & aluminum		WEBSITE DWG & SPECS - W50-5500 - Indian Challenger, TwinTEK, Rear 5.5x18
NOTICE: TO PERSONS RECEIVING THIS DRAWING AND/OR INFORMATION, RINEHART RACING CLAIMS PROPRIETARY RIGHTS TO THE MATERIAL DISCLOSED HEREIN. THIS DRAWING AND/OR TECHNICAL INFORMATION IS ISSUED IN CONFIDENCE FOR ENGINEERING INFORMATION ONLY AND MAY NOT BE REPRODUCED OR USED TO MANUFACTURE ANYTHING SHOWN OR REFERED TO HEREIN WITHOUT DIRECT WRITTEN PERMISSION FROM RINEHART RACING TO THE USER. THIS DRAWING AND/OR TECHNICAL INFORMATION IS THE PROPERTY OF RINEHART RACING AND IS LOANED FOR MUTUAL ASSISTANCE, TO BE RETURNED WHEN ITS PURPOSE HAS BEEN SERVED.			FINISH		COMPONENT NAME
			DO NOT SCALE	SCALE 1:5	SIZE B

6

5

4

3

2

1