

6

5

4

3

2

1

Brake Rotor Mtg Screws
5x M8 x 1.25 threads

Brake Rotor Mtg BCD
203.5 mm
8.012 in

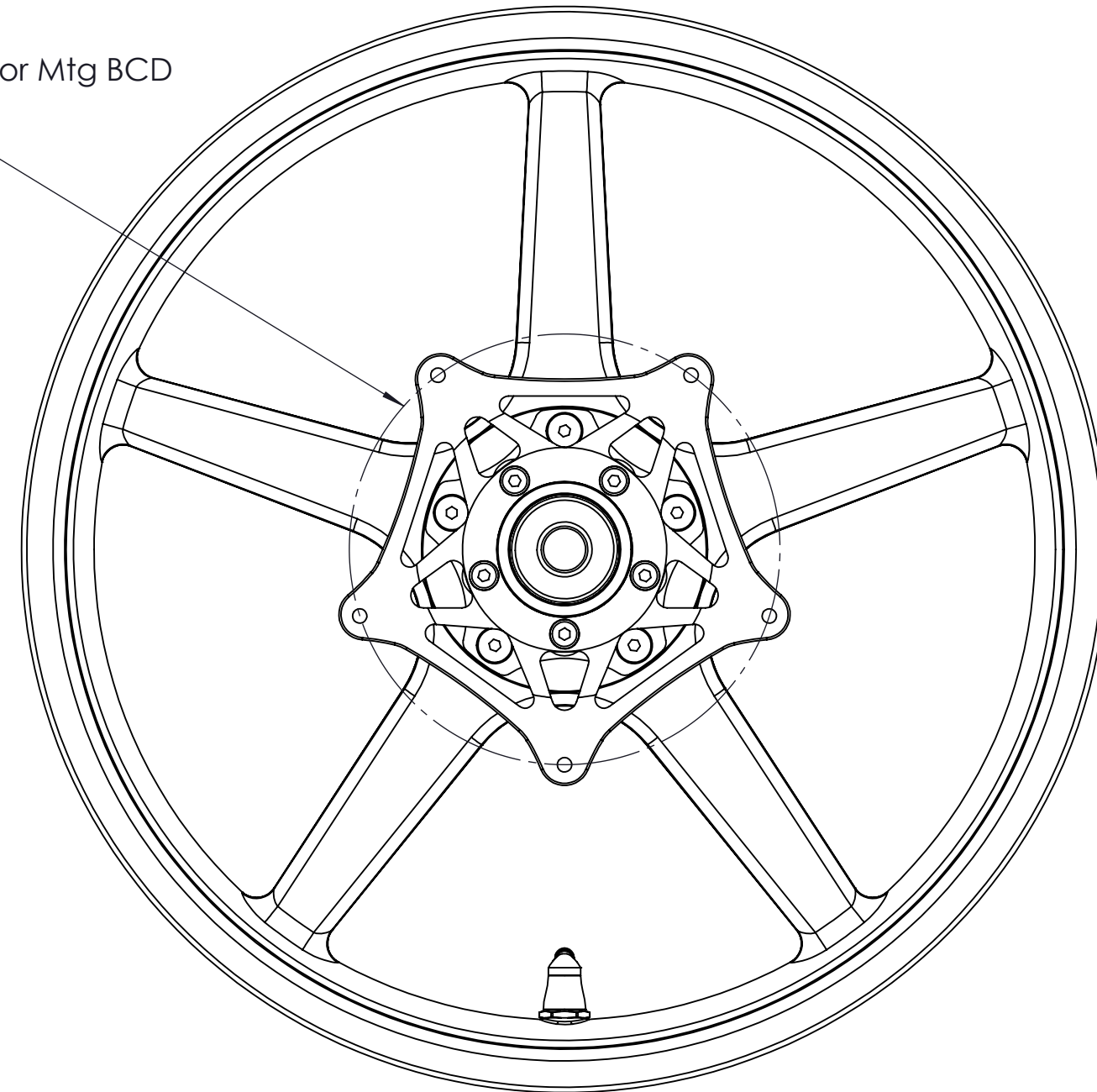

Specs - W50-3500 - Twin TEK Front:

- SIZE : 19.0" x 3.5"
- BRAKE ROTOR BCD : 203.5 mm (8.012 in)
- WEIGHT : 10.16 lbs
- STATIC LOAD RATING : 517 lbs
- APPROVALS : DOT E and JWL for street and track use
- WARRANTY : 2 Years

Notes

1. PARTS TO BE FREE OF BURRS, NICKS, SCRATCHES, COLOR DEFECTS, OILS, AND SOLVENTS.
2. PARTS TO BE PACKAGED IN SUCH A WAY TO PREVENT DAMAGE.
3. ALL SHARP EDGES TO BE BROKEN TO .0075" RADIUS UNLESS OTHERWISE NOTED.

INCH	THIRD ANGLE PROJECTION	DRAWN BY DA	DRAWN DATE 2024.04.25	RINEHART RACING
		ENG Approval	APPROVED DATE	
TOLERANCES UNLESS OTHERWISE SPECIFIED 1 PLACE DECIMAL X.X ± 0.030 2 PLACE DECIMALS X.XX ± 0.010 3 PLACE DECIMALS X.XXX ± 0.005 ANGLES ± .5° ALL DIMENSIONS ARE INCHES UNLESS OTHERWISE SPECIFIED INTERPRETATIONS OF THIS DRAWING PER ASME Y19.94M		MFG Approval	APPROVED DATE	DRAWING NUMBER
		MATERIAL carbon fiber & aluminum		WEBSITE DWG & SPECS - W50-3500 - Indian Challenger, TwinTEK, Front 3.5x19
NOTICE: TO PERSONS RECEIVING THIS DRAWING AND/OR INFORMATION, RINEHART RACING CLAIMS PROPRIETARY RIGHTS TO THE MATERIAL DISCLOSED HEREIN. THIS DRAWING AND/OR TECHNICAL INFORMATION IS ISSUED IN CONFIDENCE FOR ENGINEERING INFORMATION ONLY AND MAY NOT BE REPRODUCED OR USED TO MANUFACTURE ANYTHING SHOWN OR REFERED TO HEREIN WITHOUT DIRECT WRITTEN PERMISSION FROM RINEHART RACING TO THE USER. THIS DRAWING AND/OR TECHNICAL INFORMATION IS THE PROPERTY OF RINEHART RACING AND IS LOANED FOR MUTUAL ASSISTANCE, TO BE RETURNED WHEN ITS PURPOSE HAS BEEN SERVED.		FINISH		COMPONENT NAME
		DO NOT SCALE	SCALE 1:5	SIZE B
			SHEET 1 OF 2	REV

6

5

4

3

2

1

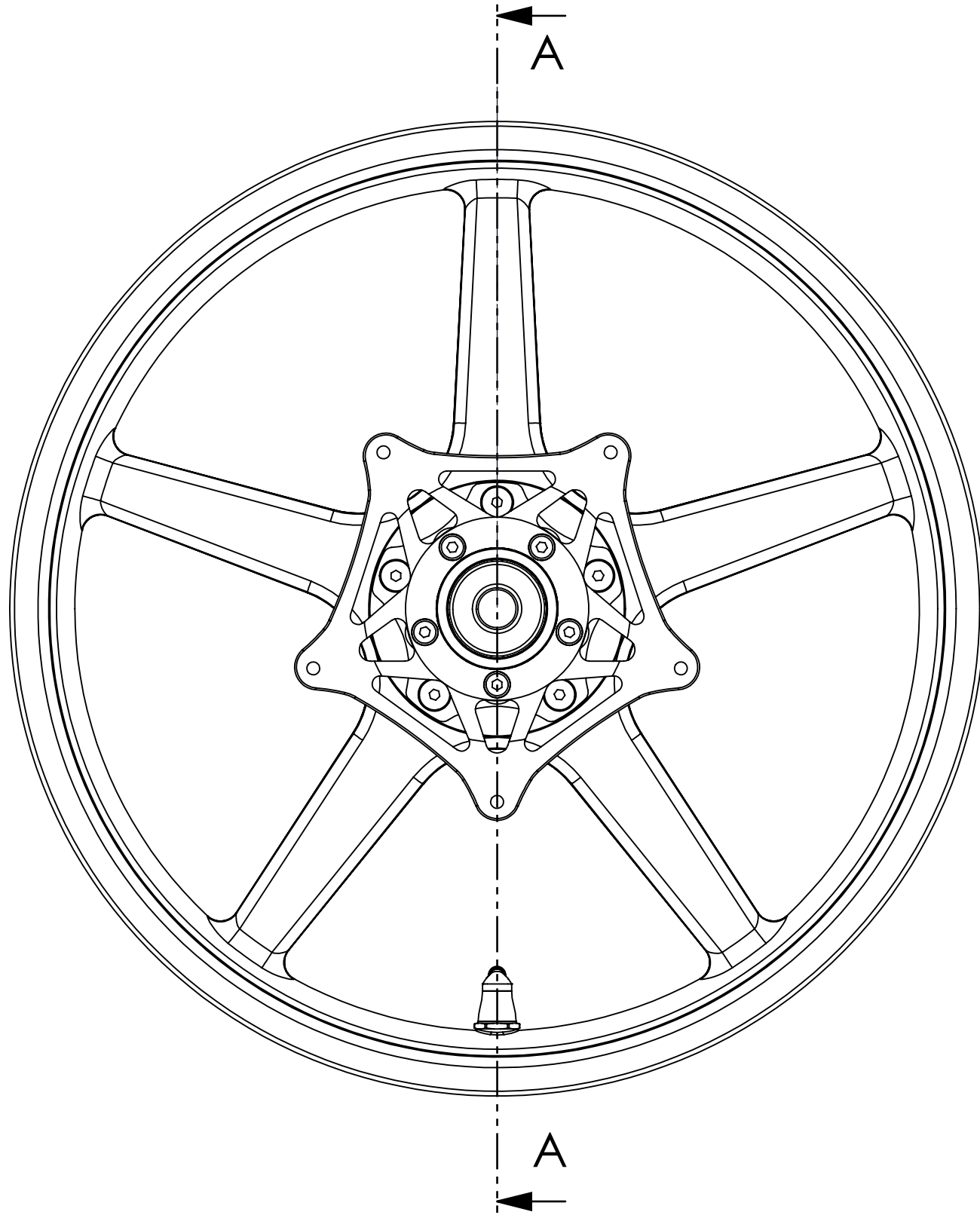

SECTION A-A

SCALE 1:3

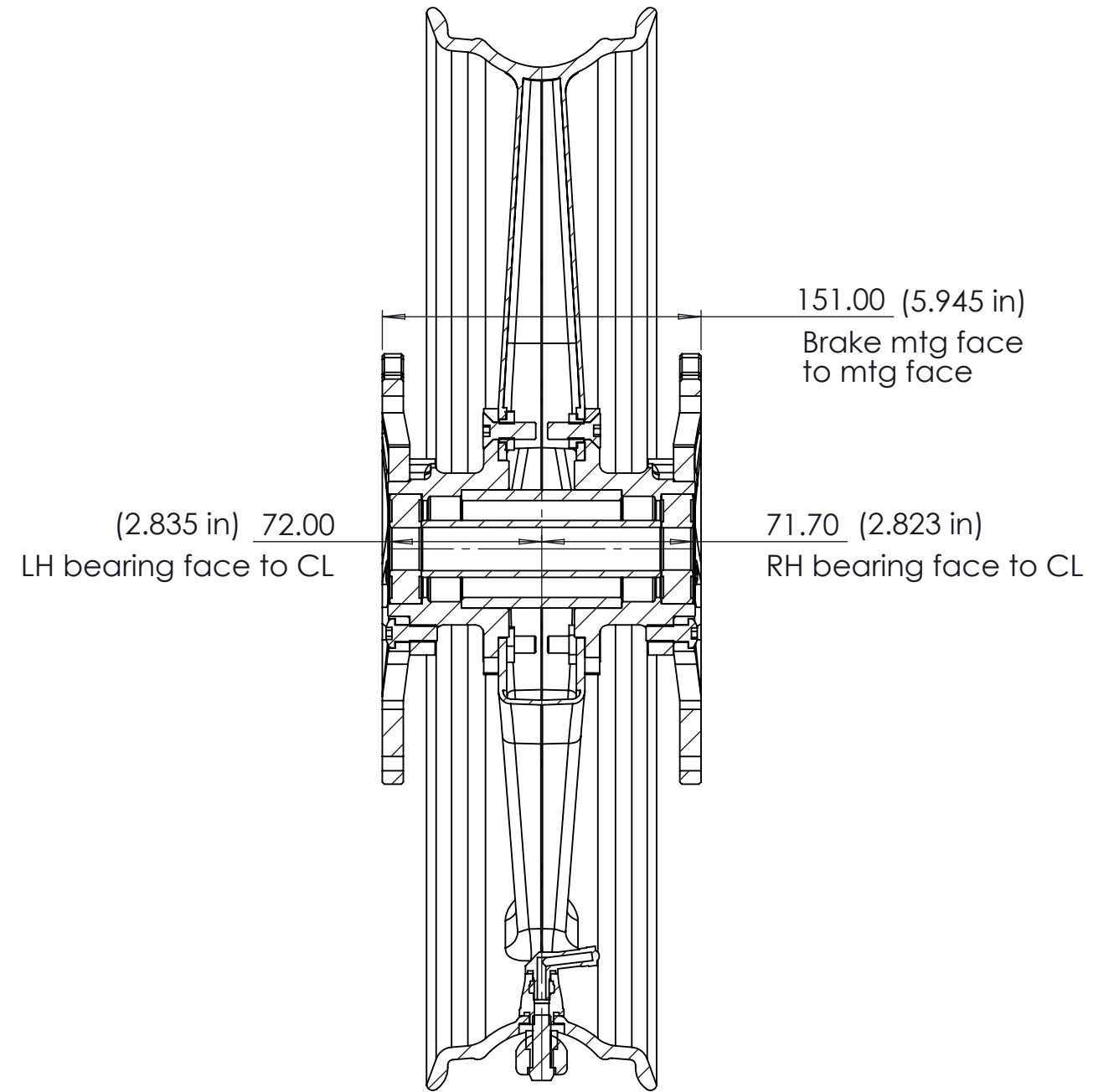

Notes

1. PARTS TO BE FREE OF BURRS, NICKS, SCRATCHES, COLOR DEFECTS, OILS, AND SOLVENTS.
2. PARTS TO BE PACKAGED IN SUCH A WAY TO PREVENT DAMAGE.
3. ALL SHARP EDGES TO BE BROKEN TO .0075" RADIUS UNLESS OTHERWISE NOTED.

INCH	THIRD ANGLE PROJECTION	DRAWN BY DA	DRAWN DATE 2024.04.25	
		ENG Approval	APPROVED DATE	
TOLERANCES UNLESS OTHERWISE SPECIFIED 1 PLACE DECIMAL X.X ± 0.030 2 PLACE DECIMALS X.XX ± 0.010 3 PLACE DECIMALS X.XXX ± 0.005 ANGLES .5± ALL DIMENSIONS ARE INCHES UNLESS OTHERWISE SPECIFIED INTERPRETATIONS OF THIS DRAWING PER ASME Y19.94M		MFG Approval	APPROVED DATE	DRAWING NUMBER WEBSITE DWG & SPECS - W50-3500 - Indian Challenger, TwintEK, Front 3.5x19
		MATERIAL carbon fiber & aluminum		COMPONENT NAME
NOTICE: TO PERSONS RECEIVING THIS DRAWING AND/OR INFORMATION, RINEHART RACING CLAIMS PROPRIETARY RIGHTS TO THE MATERIAL DISCLOSED HEREIN. THIS DRAWING AND/OR TECHNICAL INFORMATION IS ISSUED IN CONFIDENCE FOR ENGINEERING INFORMATION ONLY AND MAY NOT BE REPRODUCED OR USED TO MANUFACTURE ANYTHING SHOWN OR REFERED TO HEREIN WITHOUT DIRECT WRITTEN PERMISSION FROM RINEHART RACING TO THE USER. THIS DRAWING AND/OR TECHNICAL INFORMATION IS THE PROPERTY OF RINEHART RACING AND IS LOANED FOR MUTUAL ASSISTANCE, TO BE RETURNED WHEN ITS PURPOSE HAS BEEN SERVED.		FINISH		DRAWING RELEASE STATUS website
		DO NOT SCALE	SCALE 1:5	SIZE B