

6

5

4

3

2

1

Brake Rotor Mtg Screws  
5x M8 x 1.25 threads

Brake Rotor Mtg BCD  
170.0 mm  
6.693 in

Ø 170.00

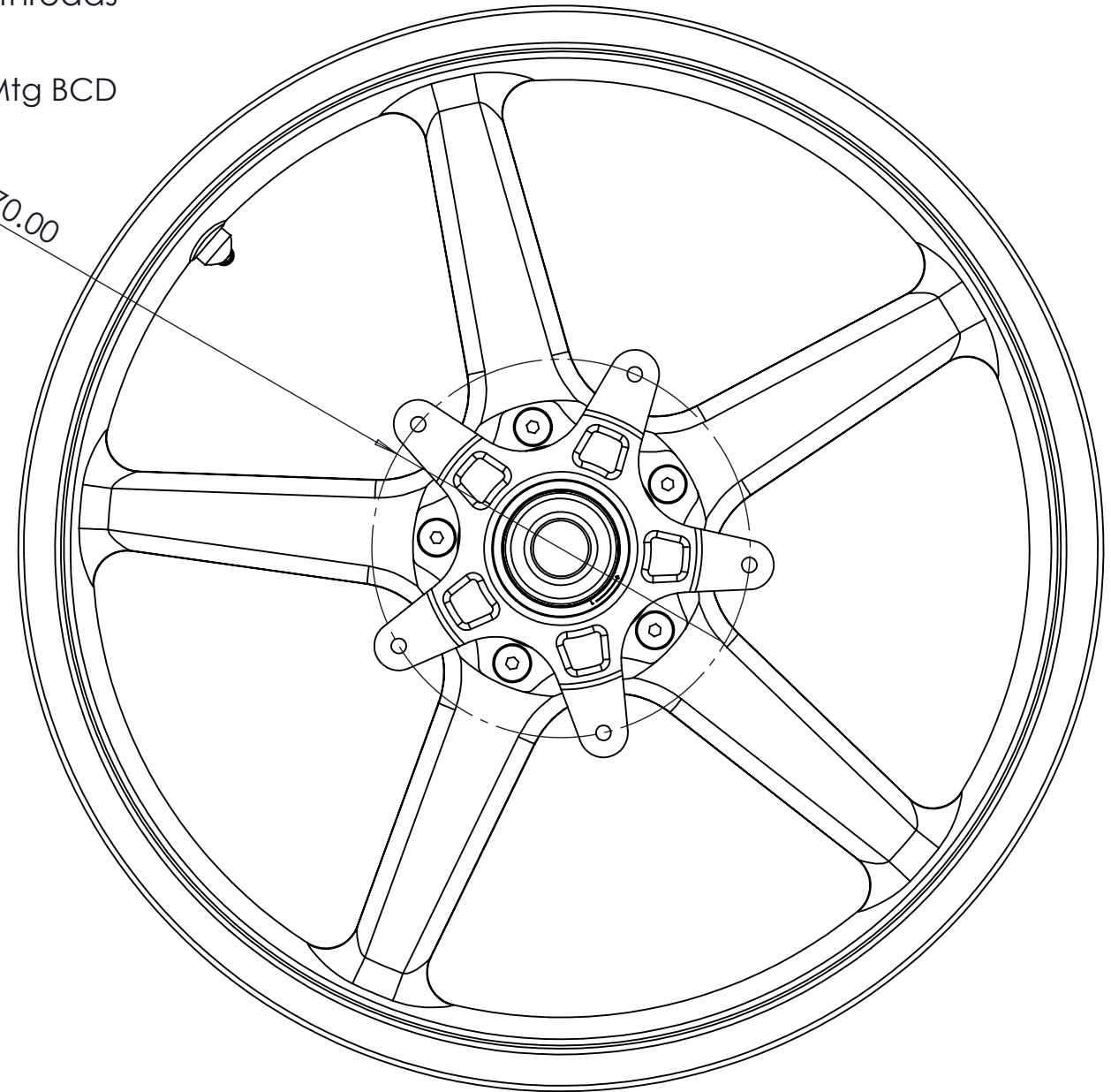

### Specs - W10-3500 - Twin TEK Front:

- SIZE : 19.0" x 3.5"
- BRAKE ROTOR BCD : 170.0 mm (6.693 in)
- WEIGHT : 9.75 lbs
- STATIC LOAD RATING : 518 lbs
- APPROVALS : DOT E and JWL for street and track use
- WARRANTY : 2 Years

INCH	 THIRD ANGLE PROJECTION	DRAWN BY <b>DA</b>	DRAWN DATE <b>2024.04.25</b>	
		ENG Approval	APPROVED DATE	
TOLERANCES UNLESS OTHERWISE SPECIFIED 1 PLACE DECIMAL X.X ± 0.030 2 PLACE DECIMALS X.XX ± 0.010 3 PLACE DECIMALS X.XXX ± 0.005 ANGLES ± .5° ALL DIMENSIONS ARE INCHES UNLESS OTHERWISE SPECIFIED INTERPRETATIONS OF THIS DRAWING PER ASME Y19.94M		MFG Approval	APPROVED DATE	DRAWING NUMBER WEBSITE DWG & SPECS - W10-3500 - HD Touring 2014-Later, TwinTEK, Front 3.5x19
NOTICE: TO PERSONS RECEIVING THIS DRAWING AND/OR INFORMATION, RINEHART RACING CLAIMS PROPRIETARY RIGHTS TO THE MATERIAL DISCLOSED HEREIN. THIS DRAWING AND/OR TECHNICAL INFORMATION IS ISSUED IN CONFIDENCE FOR ENGINEERING INFORMATION ONLY AND MAY NOT BE REPRODUCED OR USED TO MANUFACTURE ANYTHING SHOWN OR REFERED TO HEREIN WITHOUT DIRECT WRITTEN PERMISSION FROM RINEHART RACING TO THE USER. THIS DRAWING AND/OR TECHNICAL INFORMATION IS THE PROPERTY OF RINEHART RACING AND IS LOANED FOR MUTUAL ASSISTANCE, TO BE RETURNED WHEN ITS PURPOSE HAS BEEN SERVED.		MATERIAL <b>carbon fiber &amp; aluminum</b>		REFER TO PART TABLE FOR DETAIL
		FINISH		COMPONENT NAME
DO NOT SCALE	SCALE	SIZE	B	DRAWING RELEASE STATUS <b>website</b>
			SHEET	REV
			1 OF 2	

6

5

4

3

2

1

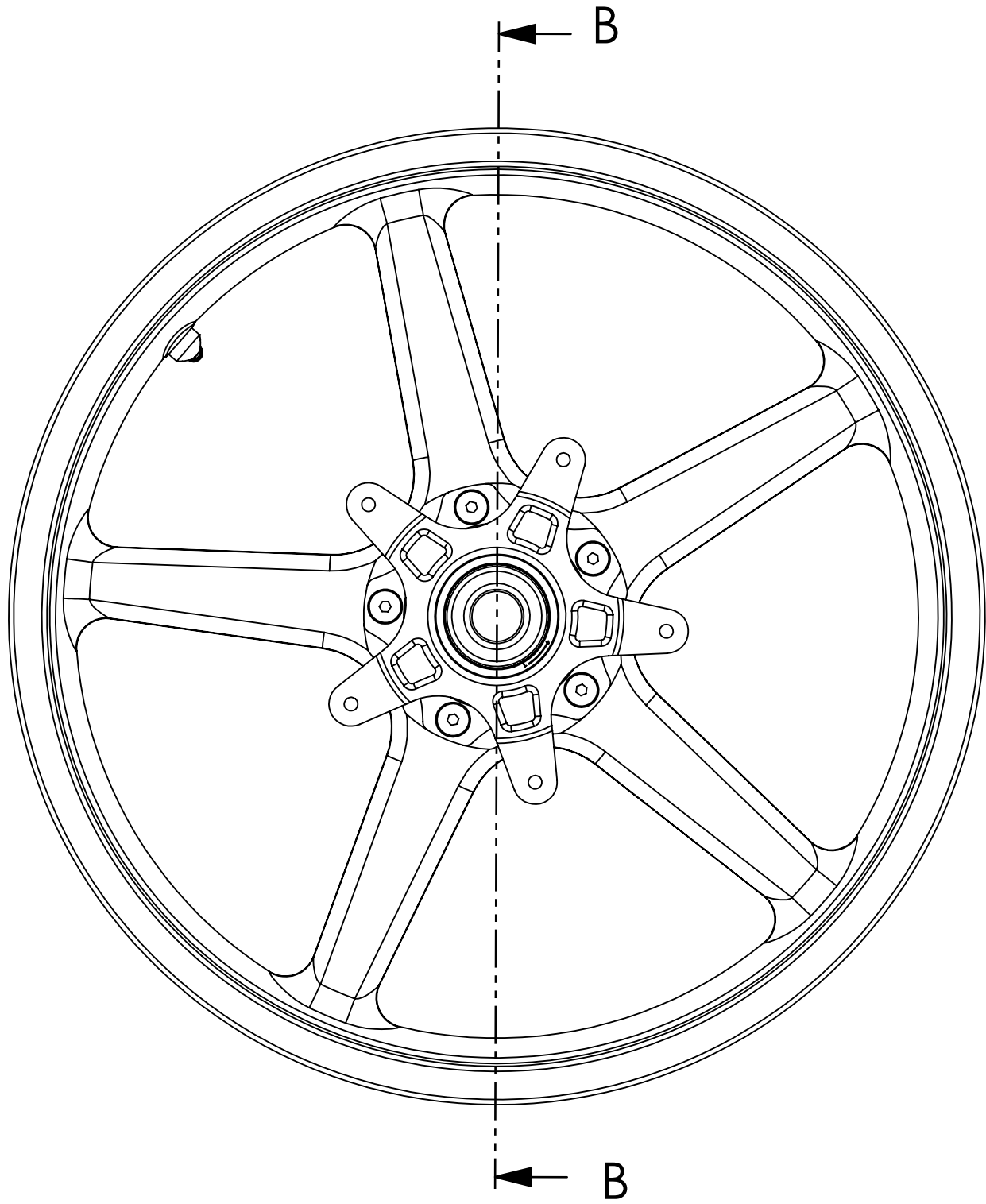

**SECTION B-B**  
SCALE 1 : 3

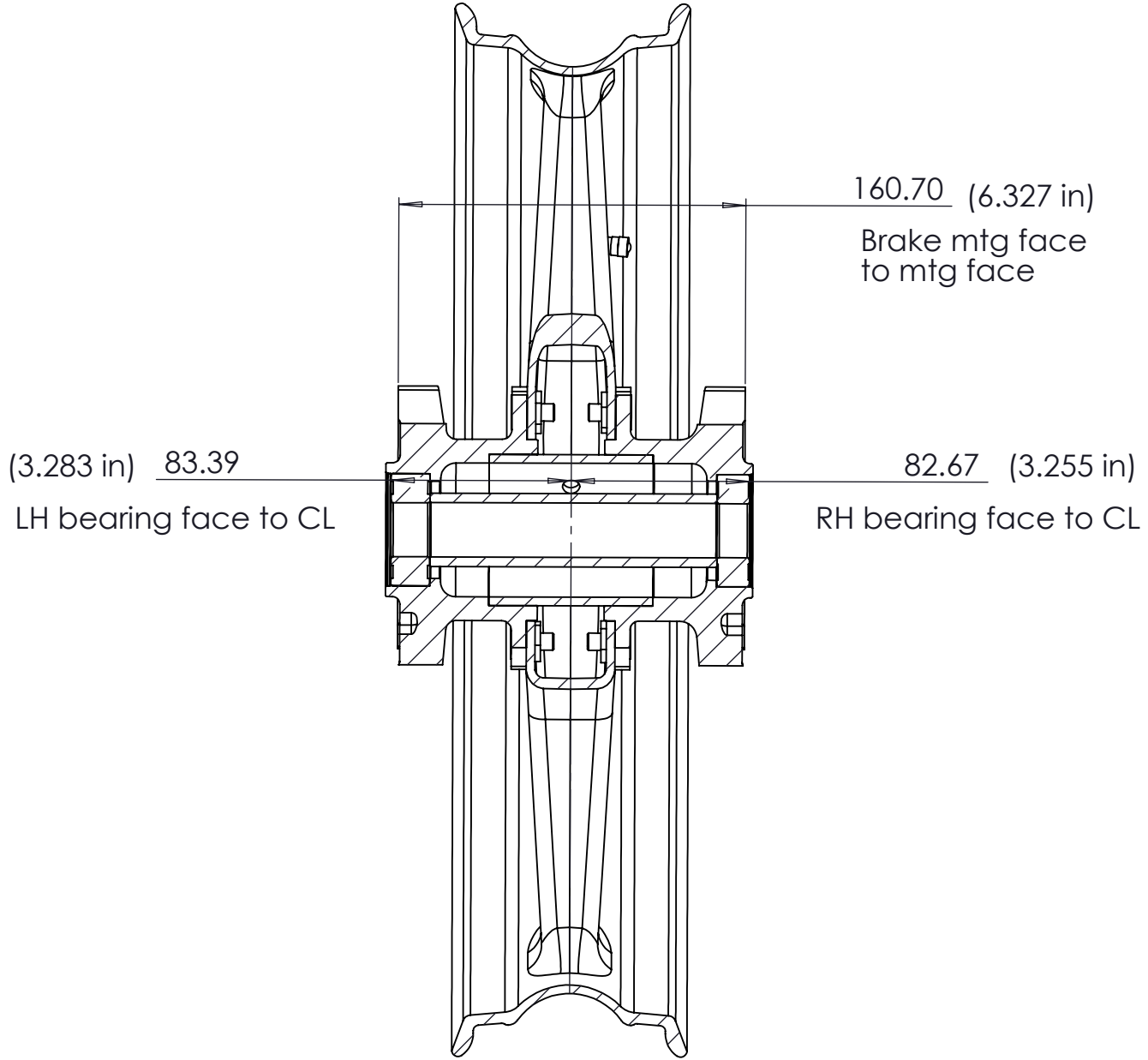

**Notes**

1. PARTS TO BE FREE OF BURRS, NICKS, SCRATCHES, COLOR DEFECTS, OILS, AND SOLVENTS.
2. PARTS TO BE PACKAGED IN SUCH A WAY TO PREVENT DAMAGE.
3. ALL SHARP EDGES TO BE BROKEN TO .0075" RADIUS UNLESS OTHERWISE NOTED.

INCH	THIRD ANGLE PROJECTION	DRAWN BY DA	DRAWN DATE 2024.04.25	
		ENG Approval	APPROVED DATE	
TOLERANCES UNLESS OTHERWISE SPECIFIED 1 PLACE DECIMAL X.X ± 0.030 2 PLACE DECIMALS X.XX ± 0.010 3 PLACE DECIMALS X.XXX ± 0.005 ANGLES .5± ALL DIMENSIONS ARE INCHES UNLESS OTHERWISE SPECIFIED INTERPRETATIONS OF THIS DRAWING PER ASME Y19.94M		MFG Approval	APPROVED DATE	DRAWING NUMBER WEBSITE DWG & SPECS - W10-3500 - HD Touring 2014-Later, TwinTEK, Front 3.5x19
NOTICE: TO PERSONS RECEIVING THIS DRAWING AND/OR INFORMATION, RINEHART RACING CLAIMS PROPRIETARY RIGHTS TO THE MATERIAL DISCLOSED HEREIN. THIS DRAWING AND/OR TECHNICAL INFORMATION IS ISSUED IN CONFIDENCE FOR ENGINEERING INFORMATION ONLY AND MAY NOT BE REPRODUCED OR USED TO MANUFACTURE ANYTHING SHOWN OR REFERED TO HEREIN WITHOUT DIRECT WRITTEN PERMISSION FROM RINEHART RACING TO THE USER. THIS DRAWING AND/OR TECHNICAL INFORMATION IS THE PROPERTY OF RINEHART RACING AND IS LOANED FOR MUTUAL ASSISTANCE, TO BE RETURNED WHEN ITS PURPOSE HAS BEEN SERVED.		MATERIAL carbon fiber & aluminum		REFER TO PART TABLE FOR DETAIL
DO NOT SCALE		SCALE 1:5	SIZE B	COMPONENT NAME
		DRAWING RELEASE STATUS website	SHEET 2 OF 2	REV